

INTRODUCTION

The KS58555B is 15 memory Tone/pulse switchable dialer with 32 digit redial memory. 16 digit indirect 10 memory and 16 digit direct 4 memory are possible. The Flash time is selectable on the keyboard. Also, Hands-Free and Hold functions are controlled on the keyboard. The KS58555B can fulfill all the standards of each country.

FEATURES

- Flash Time selectable on the keyboard (100, 303, 604 mS)
- Hands-Free and Hold functions
- Tone/Pulse switchable
- 16 digit indirect (Two-touch) 10 memory (Pulse : 16 digit, Tone : 15 digit)
- 16 digit direct (One-touch) 4 memory (Pulse : 16 digit, Tone : 15 digit)
- Uses 3.579545MHz Color burst Crystal or ceramic resonator
- Pulse rate selectable. (10 pps, 20 pps)
- Make/Break ratio selectable (40 : 60, 33 : 66)
- Single tone enable for test
- Tone (T•) key function (Pulse → Tone)
- Redial function (Pulse : 32 digit, Tone : 31 digit)
- Pin compatible with KS58006, KS58012, and KS58550

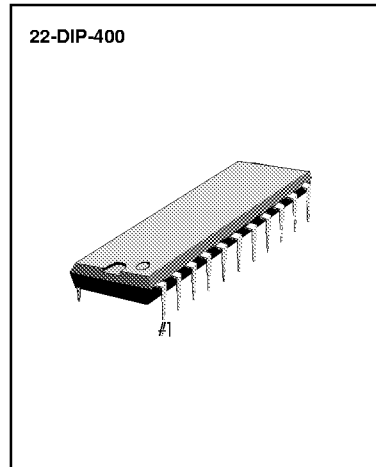

ORDERING INFORMATION

Devic	Package	Function					
		HFD	HOLD	EM	Flash Time	M/B Ratio	PPS
KS58555B	22-DIP-400	O	O	O	Selectable	Selectable	Selectable

*HFD : Hands Free Dialing Function
 *HOLD : Hold for Melody
 *EM : Emergency Memory



BLOCK DIAGRAM

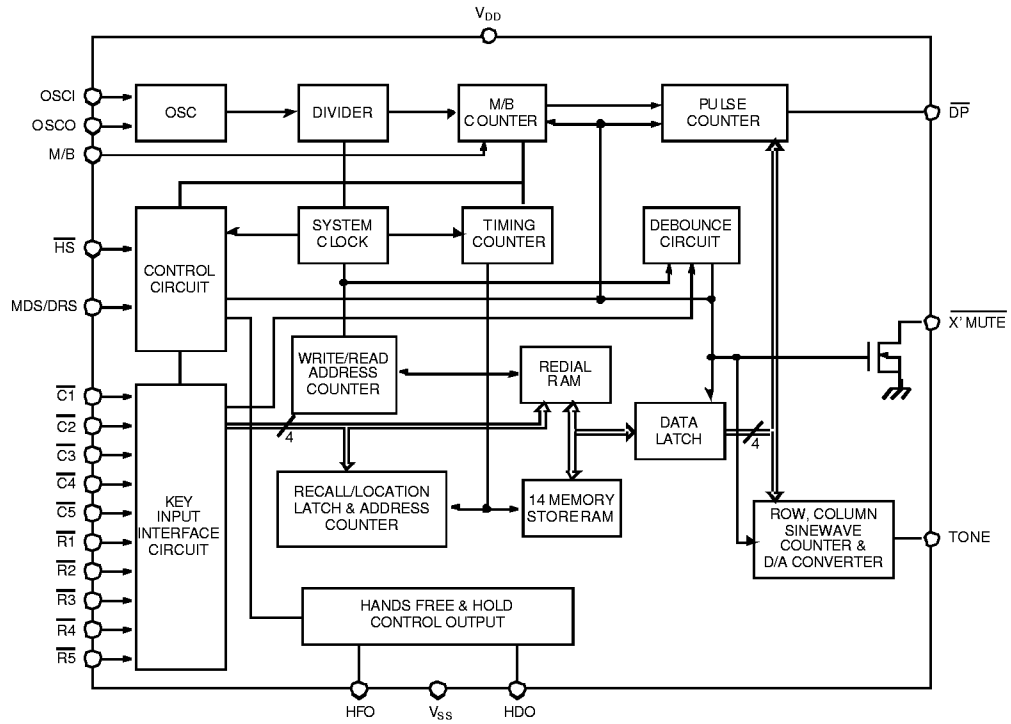

PIN CONFIGURATION

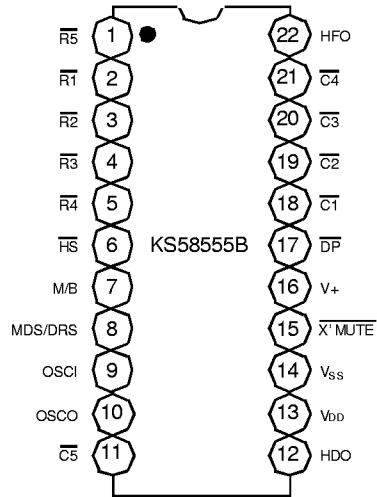

ARRANGEMENT OF KEY BOARD

1	2	3	ST	EM1
4	5	6	R/L	EM2
7	8	9	RD/P	EM3
T/	0	#	F3	EM4
HFI	HDI	F1	F2	NU

- RD/P : Redial/Pause
- ST : Store
- R/L : Recall/Location
- F1 : Flash Time (100ms)
- F2 : Flash Time (303ms)
- F3 : Flash Time (604ms)
- HFI : Hands-Free Dialing Key Input
- HDI : Hold Key Input
- T/• : Pulse → Tone Mode
- # : RD/P Function in Pulse Mode
Data in Tone Mode
- EM1 : Direct Memory Location
1 = 1, 2, 3, 4.
- Nu : Not Used Key

SELECTION FUNCTION

PIN	CONNECTION	FUNCTION
MDS/DRS	V _{DD}	PULSE MODE/20 PPS
	OPEN	PULSE MODE/10 PPS
	V _{SS}	TONE MODE
MAKE/BREAK	V _{DD}	1 : 2 (M : B)
	V _{SS}	2 : 3 (M : B)

PIN DESCRIPTION

Pin No	Symbol	I/O	Description
1	R5	I	Row Key Input
2	R1		
3	R2		
4	R3		
5	R4		
6	HS	I	Hook Switch
7	MB	I	Make/Break Select
8	MDS/DRS	I	Mode & Dial Pulse Ratio Select Pin
9	OSCI	I	Oscillator Input
10	OSCO	O	Oscillator Output
11	C5	I	Column 5 Input
12	HDO	O	Hold Function Control Output
13	V _{DD}	S	(+) Power
14	V _{SS}	S	(-) Power
15	TONE	O	Tone Output
16	X'MUTE	O	Xmute Output (N-Channel Open Drain)
17	DP	O	Dial Pulse Output (C-MOS Inverter Output)
18	C1	I	Column Key Input
19	C2		
20	C3		
21	C4		
22	HFO	O	Hands-Free Control Output

ABSOLUTE MAXIMUM RATINGS

Characteristic	Symbol	Value	Unit
Supply Voltage	V _{DD}	- 0.3 ~ 7.0	V
Input Voltage	V _I	- 0.2 ~ V _{DD} + 0.3	V
Output Voltage	V _O	- 0.3 ~ V _{DD} + 0.3	V
Power Dissipation	P _D	500	mW
Operating Temperature	T _{OPR}	- 20 ~ + 70	°C
Storage Temperature	T _{STG}	- 55 ~ + 150	°C

ELECTRICAL CHARACTERISTICS(V_{DD} = 3.5V, V_{SS} = 0V, T_a = 25°C, f_{osc} = 3.579545 MHz)

Characteristic	Symbol	Test conditions	Min	Typ	Max	Unit	
Operating Voltage	V _{DD}	-	2.0	-	6.0	V	
Memory Retention Voltage	V _{MR}	-	1.0	-	-		
Memory Retention Current	I _{MR}	HS = V _{DD} = 1.0V	-	0.05	0.1	μA	
Operating Current	I _{DD(PULSE)}	All Output Unloaded	Pulse Mode	-	0.1	0.3	mA
	I _{DD(TONE)}		Tone Mode	-	0.4	0.7	
Standby Current	I _{SB}	HS = V _{SS}	-	10	50	μA	
Output Sink Current (DP, X'MUTE)	I _{O(SINK)1}	V _{OL} = 0.4V	1.7	5.0	-	mA	
	I _{O(SINK)2}	V _{OL} = 0.4V, V _{DD} = 2.5V	0.5	1.5	-		
Output Current	I _{OH}	V _{OH} = 0.3V	1.8	5.2	-	mA	
	I _{OL}	V _{OL} = 0.4V	1.7	5.1	-		
Input Voltage	V _{IH}	R1 ~ R5, M/B, HS	0.8V _{DD}	-	V _{DD}	V	
	V _{IL}	C1 ~ C5, MDS/RDS, HS	V _{SS}	-	0.2V _{DD}		
Input Current	I _{I1}	R1 ~ R5, V _{IN} = V _{SS}	-	-	50	μA	
	I _{I2}	R1 ~ R5, V _{IN} = V _{SS} V _{DD} = 2.5V	-	-	30		
Column to Row Tone Ratio	dBcr	Tone Mode	1	2	3	dB	
Row Tone Output	V _{OH(TONE)}	R _L = 5.0Kohm	-18	-	-16	dBV	
	V _{OL(TONE)}	V _{DD} = 2.5V, R _L = 5.0Kohm	-18	-	-16		
Tone Distortion	THD	-	-	1	4	%	
Valid Key Entry Time	t _{KD}	-	-	33.3	-	mS	
Pause Time	t _{PA}	"P" Key Depress	-	3.6	-	Sec	
Pulse Interdigit Pause Time	t _{PIDP1}	MDS/DRS = V _{DD} (20 PPS)	-	600	-	mS	
	t _{PIDP2}	MDS/DRS = OPEN(10 PPS)	-	800	-		
Tone Interdigit Pause Time	t _{TIDP}	MDS/DRS = V _{SS}	-	103.5	-		
Tone Duration	t _{TD}	-	-	101	-		
Pulse to Tone Auto pause Time	t _{PTPA}	-	-	3.6	-		
Make/Break Time	t _{MB}	MDS/DRS = OPEN (10 PPS)	M/B = V _{DD}	-	33.5/67.0	-	mS
			M/B = V _{SS}	-	40.2/60.3	-	
		MDS/DRS = V _{DD} (20 PPS)	M/B = V _{DD}	-	16.7/33.5	-	
			M/B = V _{SS}	-	20.1/30.2	-	

ELECTRICAL CHARACTERISTICS(V_{DD} = 3.5V, V_{SS} = 0V, T_a = 25°C, f_{osc} = 3.579545 MHz)

Characteristic	Symbol	Test conditions	Min	Typ	Max	Unit
Pre-digit Pause Time	t _{PTPA}	MDS/DRS = V _{DD} , M/B = V _{DD}	-	17	-	mS
		MDS/DRS = OPEN, M/B = V _{DD}	-	37	-	
		MDS/DRS = V _{DD} , M/B = V _{SS}	-	20	-	
		MDS/DRS = OPEN, M/B = V _{SS}	-	30	-	
Pulse to X'MUTE Overlap Time	t _{PMO}	-	3.0	-	mS	
Flash Time	t _{FL}	F1 Key Depress	-	100	-	mS
		F2 Key Depress	-	303	-	
		F3 Key Depress	-	604	-	

APPLICATION INFORMATION KEY DESCRIPTION• **1, 2, 3, 4, 5, 6, 7, 8, 9, 0**

These are Tone/Pulse dialing signal keys in normal mode.

• **T/***

Pulse Mode : Pulse to Tone Switching Key

Tone Mode : Data Key

• **#**

Pulse Mode : No Operation

Tone Mode : Data key

• **EM1, EM2, EM3, EM4**

DIRECT REPERTORY DIALING KEY.

The cascade 32 digit dialing is available and the exceed 32 digit dialing accepted one by one after all 32 digits is dialed out.

In store mode, preasing EM1 ~ EM4 key will cause the 16 digits of buffer memory storing to corresponding repertory memory.

• **RD/P KEY**

If press this key first after off- hook, it will operate as a redial key, otherwise it will operate as a pause key.

• **ST : Store**

This key will accept as store key if press it first key after off or on - hook.

The store mode will be released by pressing this key again or hooking once.

R/L

This key will be allowed recall or location selection in indirect memory operation

F : Flash (i = 1, 2,3)

If the Flash key pressed,

\overline{DP} and \overline{XMUTE} will be forced to low during the t_{FL} (Flash Time)

F1	100mS	Flash Time Selectable on the Keyboard
F2	303mS	
F3	604mS	

HFI

Hands-Free dialing input.

Hands-Free dialing output controlled by the keyboard (HFI)

HDI

Hold function input.

Hold function controlled by the keyboard (HDI).

The output will control the melody enable.

KEYBOARD AND SWITCH OPERATION**SYMBOL DEFINITION**

D_p =PULSE DATA : 0,1,2,3,4,5,6,7,8,9,F, PAUSE

D_t =TONE DATA : 0,1,2,3,4,5,6,7,8,9, *,#,F, PAUSE

EM1 ~ EM4 = DIRECT MEMORY

REC = RECALL

LOC = LOCATION

ZiZiZi = Conversation Mode

OFF= OFF-HOOK

ON = ON-HOOK

= INPUT LEVEL LOW TO HIGH

= INPUT LEVEL HIGH TO LOW

OPERATION MANUAL

- NORMAL DIALING IN PULSE MODE

OFF: $D_{p,-}$, D_p , : ZiZiZi : ON

- NORMAL DIALING IN TONE MODE

OFF: $D_{t,-}$, D_t , : ZiZiZi : ON

- NORMAL DIALING FROM PULSE TO TONE VIA T/* KEY

OFF: $D_{p,-}$, D_p , T/*, D_t , : ZiZiZi : ON

- NORMAL DIALING FROM PULSE TO TONE VIA MDS/DRS SWITCH

OFF: $D_{p,-}$, D_p , MDS/DRS, \downarrow , D_t , ----, D_t , : ZiZiZi : ON

- REDIAL

OFF: RD/P : ZiZiZi : ON

NOTE : 1) All the key input will be ignored during the redial.

2) if the dialing digits exceed 32 digits, the redialing operation will be inhibited)

3) Cascade dialing (normal dialing after redialing) will be accepted.

- REPERTORY DIALING FOR CASCADED MEMORY
 OFF: EMI (i=1,2,3,4) : ZIZIZI : ON: DIRECT
 OFF: REC, LOCx (x=1,2,-, 0): ZIZIZI : ON : INDIRECT
- REPERTORY DIALING FOR CASCADED MEMORY
 The cascade 32 digit dialing is available and exceed 32 digit dialing accepted one by one after all 32 digits are dialed out.
- NORMAL DIALING AFTER REPERTORY DIALING
 OFF: EMI (i=1,2,3,4) or REC, LOCx (x=1,2,-, 0),
 Dg,-, Dg, : ZIZIZI : ON
- STORE
 ON/OFF, ST, Dg,-, Dg EMI OR LOCx
 Store mode will be released by pressing store key again or hooking once.
- STORE
 ON/OFF, ST, Dg,-, Dg, EMI OR LOCx
 Store mode will be released by pressing store key again or hooking once.
- CHANGING STORE DATA VIA F KEY
 ON/OFF, ST, D1 ,D2,D3,F,D4,D5,D6, -, Dn, EMI or LOCx
 In above dialing sequence, the storing data are D4,D5,D6,Dn.
- HANDS FREE DIALING
 ON : HFI, D1, D2,-, Dn, : OFF : ZIZIZI : ON
 ON : HFI, D1, D2,-, Dn, HFI,RD
- HOLD FUNCTION
 This pin controls the melody output enable and disable.
 (Refer to state diagram of hands-free dialing & hold function)

TRUTH TABLE OF HANDS-FREE INPUT & HOLD FUNCTION

NO	CURRENT STATE			INPUT	NEXT STATE		
	HOOK STATE	HFO	HDO		HFO	HDO	DIALING
1	ON/OFF HOOK	L	L	HFI KEY IN	H	L	YES
2	ON HOOK	H	L	HFI KEY IN	L	L	NO
3	OFF HOOK	H	L	HFI KEY IN	L	L	YES
4	ON HOOK	X	X	OFF HOOK	L	L	YES
5	OFF HOOK	X	H	ON HOOK	P	P	MELODY ON
6	OFF HOOK	L	L	ON HOOK	L	L	NO
7	OFF HOOK	H	L	ON HOOK	H	L	YES
8	ON HOOK	L	X	HDI KEY IN	L	P	NO
9	ON HOOK	H	L	HDI KEY IN	H	H	MELODY ON
10	ON HOOK	H	H	HDI KEY IN	H	L	YES
11	OFF HOOK	X	L	HDI KEY IN	P	H	MELODY ON
12	OFF HOOK	X	H	HDI KEY IN	P	L	YES
13	ON/OFF HOOK	X	H	HDI KEY IN	P	H	MELODY ON

*Comment : X : Don't Care
 P : Previous State



TIMING DIAGRAM

1) PULSE MODE

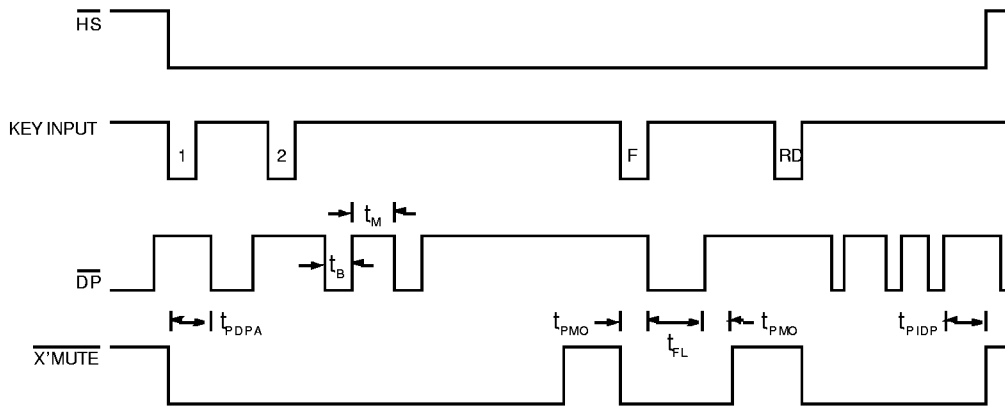

2) TONE MODE

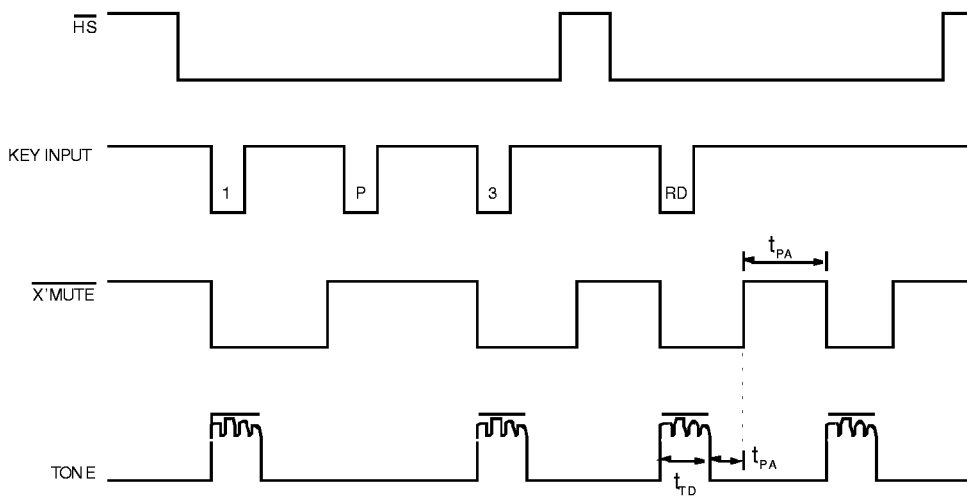

3) PULSE TO TONE DIALING

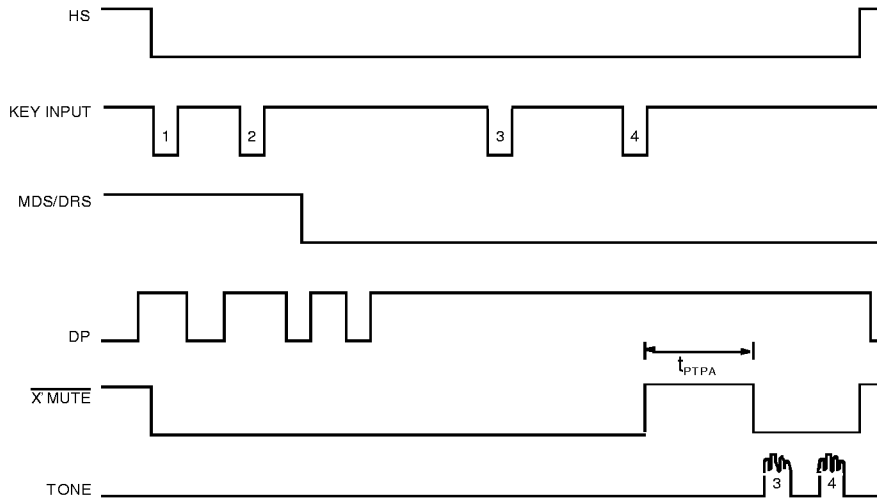

4) HANDS-FREE DIALING & HOLD FUNCTION

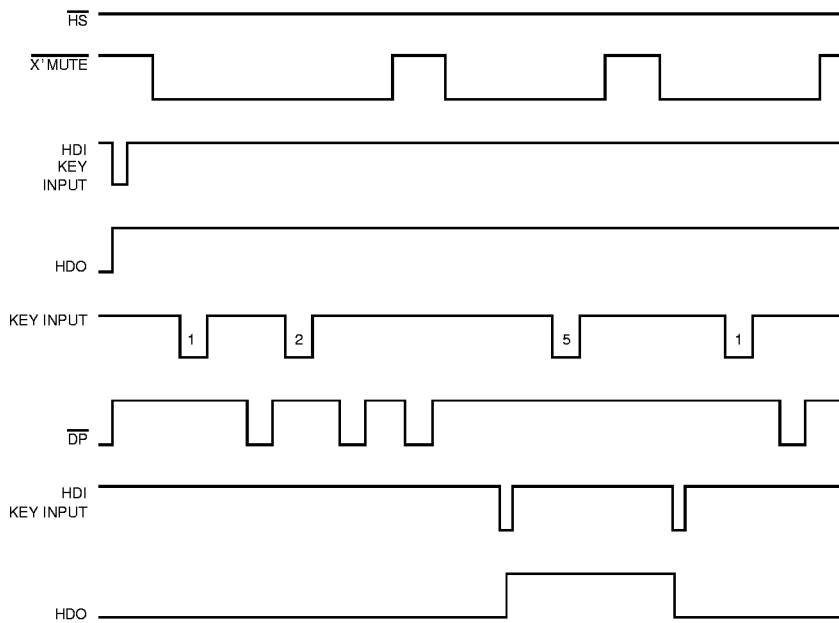

APPLICATION CIRCUIT

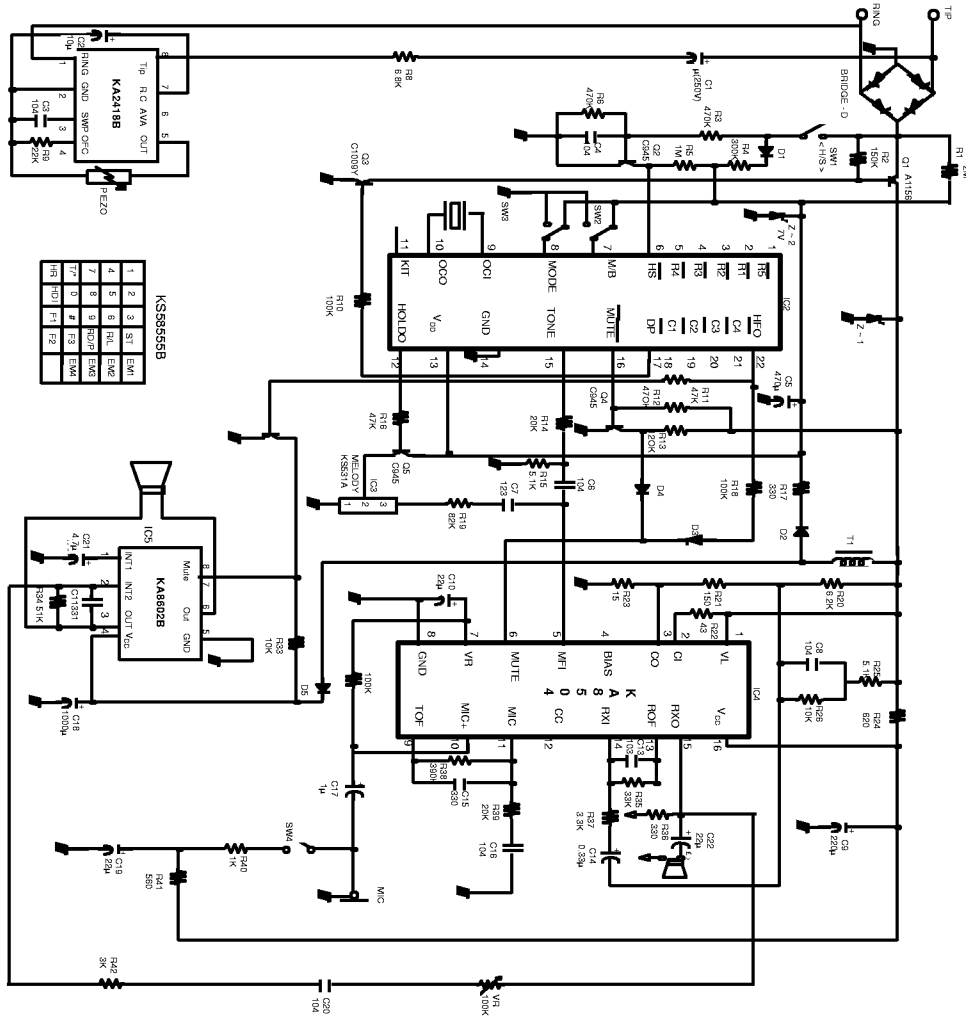

22-DIP-300B

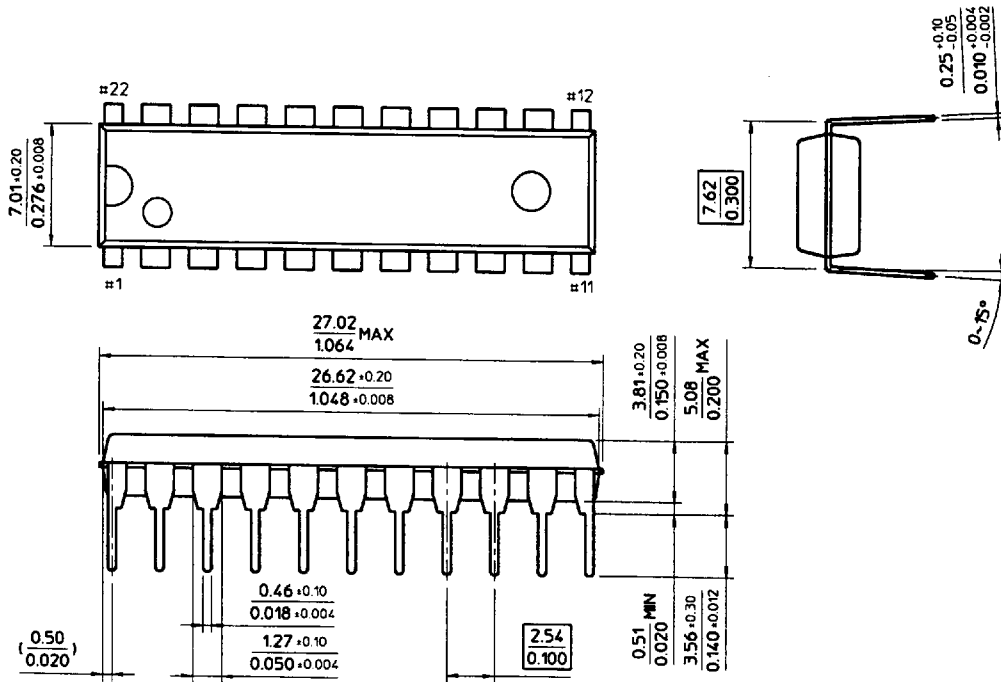

22-DIP-400

