



**ATF-26550 (AT-10650-5)**  
**2-16 GHz General Purpose**  
**Gallium Arsenide FET**

**Features**

- **High Associated Gain:** 8.0 dB typical at 12 GHz
- **High Output Power:** 18.0 dBm typical P<sub>1</sub> dB at 12 GHz
- **Low Noise Figure:** 2.5 dB typical at 12 GHz
- **Hermetic Gold-Ceramic Microstrip Package**

**Description**

The ATF-26550 is a high performance gallium arsenide Schottky-barrier-gate field effect transistor housed in a hermetic, high reliability package. Its noise figure makes this device appropriate for use in the gain stages of low noise amplifiers operating in the 2-16 GHz frequency range.

This GaAs FET device has a nominal 0.3 micron gate length with a total gate periphery of 250 microns. Proven gold based metallization systems and nitride passivation assure a rugged, reliable device.

**50 mil Package**

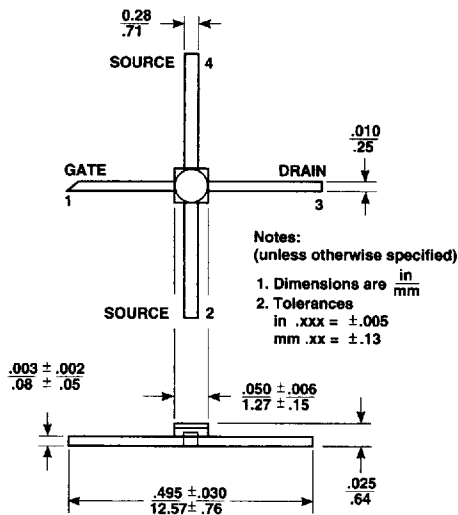

INSERTION POWER GAIN, MAXIMUM AVAILABLE GAIN AND MAXIMUM STABLE GAIN vs. FREQUENCY  
 V<sub>DS</sub> = 3 V, I<sub>DS</sub> = 10 mA, T<sub>A</sub> = 25°C

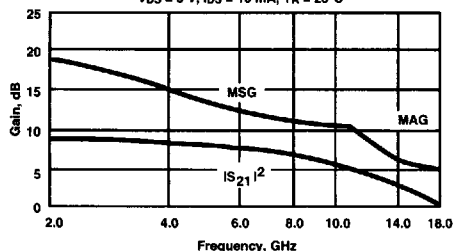

**Electrical Specifications, T<sub>A</sub> = 25°C**

Symbol	Parameters and Test Conditions	Units	Min.	Typ.	Max.
NFO	Optimum Noise Figure: V <sub>DS</sub> = 3 V, I <sub>DS</sub> = 10 mA	f = 8.0 GHz f = 12.0 GHz f = 14.0 GHz		2.2 2.5 2.7	2.8
GA	Gain @ NFO: V <sub>DS</sub> = 3 V, I <sub>DS</sub> = 10 mA	f = 8.0 GHz f = 12.0 GHz f = 14.0 GHz	7.0	10.0 8.0 7.0	
P <sub>1</sub> dB	Output Power @ 1 dB Gain Compression: V <sub>DS</sub> = 5 V, I <sub>DS</sub> = 30 mA	f = 12.0 GHz		18.0	
G <sub>1</sub> dB	1 dB Compressed Gain: V <sub>DS</sub> = 5 V, I <sub>DS</sub> = 30 mA	f = 12.0 GHz		7.5	
g <sub>m</sub>	Transconductance: V <sub>DS</sub> = 3 V, V <sub>GS</sub> = 0 V		20	40	
I <sub>DSS</sub>	Saturated Drain Current: V <sub>DS</sub> = 3 V, V <sub>GS</sub> = 0 V		30	50	90
V <sub>P</sub>	Pinchoff Voltage: V <sub>DS</sub> = 3 V, I <sub>DS</sub> = 1 mA		-3.0	-1.7	-0.8

**Absolute Maximum Ratings**

Parameter	Symbol	Absolute Maximum <sup>1</sup>
Drain-Source Voltage	V <sub>DS</sub>	+7 V
Gate-Source Voltage	V <sub>GS</sub>	-4 V
Drain Current	I <sub>DS</sub>	I <sub>DSS</sub>
Power Dissipation <sup>2,3</sup>	P <sub>T</sub>	275 mW
Channel Temperature	T <sub>CH</sub>	175°C
Storage Temperature	T <sub>STG</sub>	-65°C to +175°C

Thermal Resistance:  $\theta_{jc} = 325^\circ\text{C/W}$ ; T<sub>CH</sub> = 150°C  
 Liquid Crystal Measurement; 1  $\mu\text{m}$  Spot Size<sup>4</sup>

**Notes:**

1. Operation of this device above any one of these parameters may cause permanent damage.
2. Case Temperature = 25°C.
3. Derate at 3 mW/°C for T<sub>CASE</sub> > 86°C.
4. The small spot size of this technique results in a higher, though more accurate determination of  $\theta_{jc}$  than do alternate methods. See MEASUREMENTS section for more information.

**Typical Performance, T<sub>A</sub> = 25°C**  
 (unless otherwise noted)

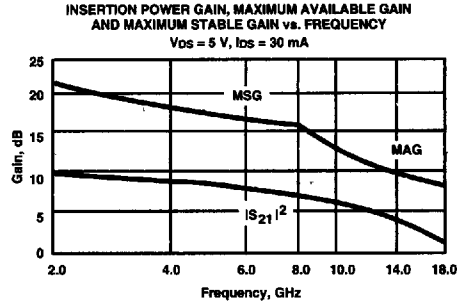

**Typical Scattering Parameters: Common Source, Z<sub>0</sub> = 50  $\Omega$**

T<sub>A</sub> = 25°C, V<sub>DS</sub> = 3 V, I<sub>DS</sub> = 10 mA

Freq. GHz	S <sub>11</sub>		S <sub>21</sub>			S <sub>12</sub>			S <sub>22</sub>	
	Mag	Ang	dB	Mag	Ang	dB	Mag	Ang	Mag	Ang
2.0	.95	-36	8.1	2.53	148	-28.0	.040	64	.75	-18
3.0	.92	-51	7.6	2.41	133	-24.7	.058	55	.71	-26
4.0	.90	-67	7.2	2.30	118	-22.4	.076	43	.68	-39
5.0	.87	-82	6.8	2.18	102	-20.5	.094	34	.64	-49
6.0	.84	-97	6.3	2.06	87	-19.0	.112	24	.60	-58
7.0	.80	-118	6.4	2.08	70	-18.2	.123	7	.55	-71
8.0	.73	-140	6.2	2.04	53	-17.4	.135	-5	.47	-85
9.0	.71	-161	5.8	1.95	35	-17.0	.142	-17	.43	-103
10.0	.67	-178	5.2	1.81	18	-16.7	.146	-27	.42	-120
11.0	.66	167	4.4	1.66	5	-16.8	.144	-39	.41	-134
12.0	.64	150	4.0	1.59	-10	-17.1	.140	-49	.40	-144
13.0	.63	133	3.6	1.51	-23	-17.4	.135	-59	.38	-154
14.0	.63	115	3.0	1.42	-38	-17.5	.133	-66	.36	-172
15.0	.62	99	2.5	1.34	-53	-17.7	.130	-74	.35	158
16.0	.62	89	1.7	1.22	-67	-17.9	.128	-88	.40	134
17.0	.63	81	1.0	1.11	-79	-17.9	.127	-91	.44	123
18.0	.62	70	0.1	1.01	-92	-17.8	.129	-94	.48	118

T<sub>A</sub> = 25°C, V<sub>DS</sub> = 5 V, I<sub>DS</sub> = 30 mA

2.0	.96	-38	9.0	2.82	144	-32.8	.023	69	.75	-20
3.0	.92	-52	8.4	2.62	130	-30.2	.031	70	.75	-28
4.0	.89	-66	7.9	2.48	116	-27.5	.042	68	.76	-36
5.0	.85	-82	7.8	2.46	100	-25.4	.054	65	.76	-47
6.0	.78	-102	7.7	2.43	84	-24.0	.063	46	.71	-57
7.0	.71	-124	7.5	2.38	66	-23.9	.064	30	.66	-68
8.0	.68	-144	7.2	2.30	52	-23.6	.066	25	.63	-78
9.0	.64	-163	7.0	2.23	37	-23.2	.069	19	.62	-86
10.0	.62	-178	6.4	2.08	21	-23.2	.069	12	.61	-99
11.0	.60	165	5.7	1.93	8	-23.1	.070	5	.61	-112
12.0	.60	149	5.2	1.82	-6	-23.1	.070	-3	.60	-124
13.0	.59	131	4.7	1.71	-21	-23.1	.070	-8	.60	-138
14.0	.59	122	4.1	1.60	-34	-22.5	.075	-15	.60	-152
15.0	.62	105	3.3	1.47	-48	-21.9	.080	-20	.59	-162
16.0	.61	93	3.0	1.42	-60	-21.5	.084	-25	.58	175
17.0	.62	83	2.2	1.29	-74	-21.1	.088	-31	.60	161
18.0	.63	73	1.1	1.13	-85	-20.3	.097	-40	.65	145

A model for this device is available in the DEVICE MODELS section.