

# Types VOZ-75, VOZ-11, and VOY-11 Outdoor voltage transformers

## Product features

- 8.7 and 15 kV, outdoor
- 75 and 110 kV BIL, 60 Hertz
- Primary volts: 2400 - 14400
- Electrical clearances:
  - Strike: 11.5" (292 mm)
  - Creep: 28.2" (716 mm)
- Approximate weight: 75 lbs (34 kg)

## Application

The VOZ-75, VOZ-11, and VOY-11 outdoor voltage transformers are designed for outdoor metering and relaying applications.

## Construction features

The primary and secondary coils are wound using special winding and shielding techniques for improved voltage stress distribution. Each coil is carefully insulated with mylar film to provide a high dielectric medium between layers. The completed winding structure and double-loop cores are assembled to a support frame.

For insulation and protection, the assembly is cast in hydrophobic cycloaliphatic epoxy (HCEP) using automatic pressure gelation. The HCEP material offers superior arc track, ozone, and ultraviolet-resistant properties while maintaining physical strength. The hydrophobic surface properties of HCEP ensure highly reliable performance in wet, humid, or polluted environments.

## Terminals

Electro-tin plated copper primary line terminals accommodate #10 to 250 MCM conductors. Clamp-type secondary terminals accommodate #14 through #3 wire. A ground terminal is also provided for grounding the secondary circuit at the transformer.

## Junction box

The junction box has a 1" conduit hub on either end and a knock out for a 1" conduit fitting on the bottom. The box is anchored to the body of the transformer with screws and can be easily detached, simplifying installation and change-out procedures.

## Baseplate

The base is constructed of corrosion-resistant aluminum and is secured to the encapsulated base support.



## Mounting

The VOZ-75, VOZ-11, and VOY-11 units can be mounted in upright, cantilever, or upside-down positions. Stress relief devices should be used to support cable connections.

## Test reports

Test reports are stored electronically and can be e-mailed in various formats at the time of shipment.

## Standards

These units can be tested to all applicable IEEE, CSA, or IEC standards as requested.

## Unit dimensions

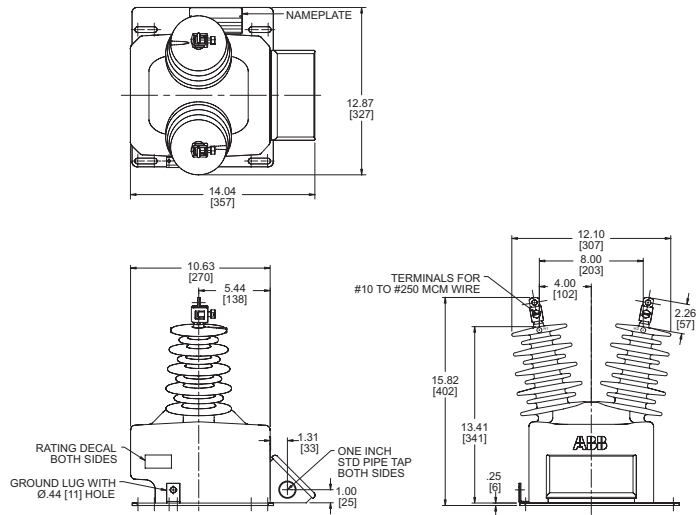

## Types VOZ-75, VOZ-11, or VOY-11

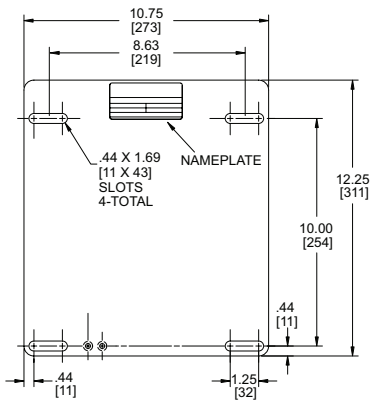

## Baseplate dimensions

## Optional accessories

These units are designed for mounting on poles or substation structures, with high voltage bushings in either vertical or horizontal positions. When mounted with high voltage bushings in a horizontal plane, it is recommended that this plane be parallel to the ground and not one bushing above the other. This precaution prevents formation of ice and snow which could cause flashover between bushings.

- Vertical mounting with mounting brackets & back-up plates:  
Mounting bracket: 463C035G02  
Back-up plate: 28D2876G01
- Vertical mounting with mounting brackets and hangers:  
Mounting bracket: 463C035G02  
Hangers: 261A233G01
- Vertical mounting with channel brackets for tandem mounting of voltage and current transformers:  
Channel bracket: 332B955G02
- Horizontal mounting with hangers:  
Hangers: 261A233G01

## Selection guide

Primary ampere rating	Secondary voltage	Winding ratio	Metering accuracy	Style number
<b>Type VOZ-75</b>				
2400/4160Y	120	20:1	0.3Z	E-7525A89G01
4200/7280Y	120	35:1	0.3Z	E-7525A89G02
4800/8320Y	120	40:1	0.3Z	E-7525A89G03
7200/7200Y	120	60:1	0.3Z	E-7525A89G04
<b>Type VOZ-11</b>				
7200/12470Y	120	60:1	0.3Z	E-7525A89G05
7620/13200Y	120	63.5:1	0.3Z	E-7525A89G06
8400/14560Y	120	70:1	0.3Z	E-7525A89G07
12000/12000Y	120	100:1	0.3Z	E-7525A89G08
13200/13200Y	120	110:1	0.3Z	E-7525A89G09
14400/14400Y	120	120:1	0.3Z	E-7525A89G10
<b>Type VOY-11</b>				
7200/12470Y	120	60:1	0.3Y	E-7525A23G05
7620/13200Y	120	63.5:1	0.3Y	E-7525A23G06
8400/14560Y	120	70:1	0.3Y	E-7525A23G07
12000/12000Y	120	100:1	0.3Y	E-7525A23G08
13200/13200Y	120	110:1	0.3Y	E-7525A23G09
14400/14400Y	120	120:1	0.3Y	E-7525A23G10

Thermal rating at 30° C: 1500

Rated voltage factor (RVF): 1.1

For 50 Hz styles, contact the factory.

Additional styles available upon request. Contact your ABB sales representative or call +1-252-827-3212 for more information.

For more information please contact:

## ABB Inc.

### Medium Voltage Distribution Components

3022 NC 43 North

Pinetops, NC 27864

USA

Phone: +1 252 827 3212

Fax: +1 252 827 4286

[www.abb.com/mediumvoltage](http://www.abb.com/mediumvoltage)

## Note:

The information contained in this document is for general information purposes only. While ABB strives to keep the information up to date and correct, it makes no representations or warranties of any kind, express or implied, about the completeness, accuracy, reliability, suitability, or availability with respect to the information, products, services, or related graphics contained in the document for any purpose. Any reliance placed on such information is therefore strictly at your own risk. ABB reserves the right to discontinue any product or service at any time.

Copyright 2006 ABB.

All rights reserved.

Power and productivity  
for a better world™

