

SPECIFICATIONS

Contact Current Rating: 1A
 Dielectric Withstanding Voltage: 500V AC R.M.S
 Insulation Resistance: 500Megohms Min At DC 500V
 Contact Resistance: 30Milliohms Max.
 Operating Temperature: -55°C To +105°C
 Contact Insertion Force: 4.0kg Max
 Contact Separation Force: 0.5kg Min.
 Insulator: PBT, UL94V-0 Rated
 Contact: Brass or Phosphor Bronze,
 Gold Flashed 3u",5u",10u",15u",30u"
 Shell: Brass, Nickel, Tin or Gold Plated

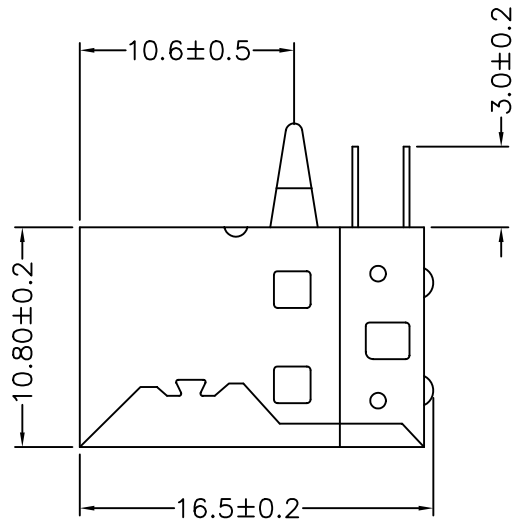
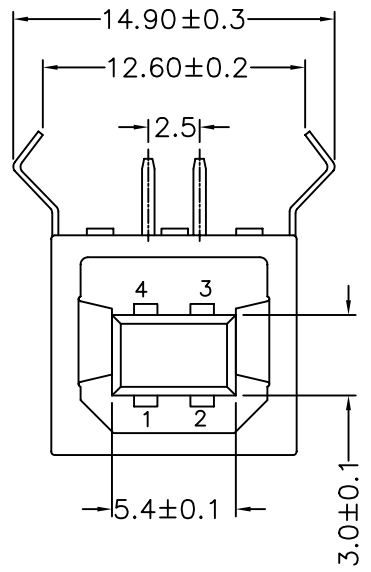

AUK A NUMBER OF AUK GROUP
 太聯事業股份有限公司
 AUK CONTRACTORS CO., LTD.

DRAWING No. USB2X02SR

APPROVED BY MEI
 CHECKED BY RAN
 DRAWING BY HZF

UNLESS OTHERWISE SPECIFIED TOLERANCES ARE
 .X ±0.38
 .XX ±0.25
 ANG.

SCALE	NONE	REV.	B	UNIT	mm	AREA	REVISIONS	CHK	DATE
-------	------	------	---	------	----	------	-----------	-----	------