



## 128Kx32 SRAM MODULE, SMD 5962-93187 & 5962-95595

### FEATURES

- Access Times of 15, 17, 20, 25, 35, 45, 55ns
- MIL-STD-883 Compliant Devices Available
- Packaging
  - 66 pin, PGA Type, 1.075" square, Hermetic Ceramic HIP (Package 400)
  - 68 lead, 40mm CQFP (G4T)<sup>1</sup>, 3.56mm (0.140") (Package 502)
  - 68 lead, 22.4mm CQFP (G2U), 3.56mm (0.140"), (Package 510)
  - 68 lead, 22.4mm (0.880") square, CQFP (G2L), 5.08mm (0.200") high, (Package 528)
- Organized as 128Kx32; User Configurable as 256Kx16 or 512Kx8
- Commercial, Industrial and Military Temperature Ranges
- 5 Volt Power Supply
- Low Power CMOS
- TTL Compatible Inputs and Outputs
- Built in Decoupling Caps and Multiple Ground Pins for Low Noise Operation
- Weight:
  - WS128K32-XG2UX - 8 grams typical
  - WS128K32-XG2LX - 8 grams typical
  - WS128K32-XH1X - 13 grams typical
  - WS128K32-XG4TX<sup>1</sup> - 20 grams typical
- Devices are upgradeable to 512Kx32

This product is subject to change without notice.

**FIGURE 1 – PIN CONFIGURATION FOR WS128K32N-XH1X**

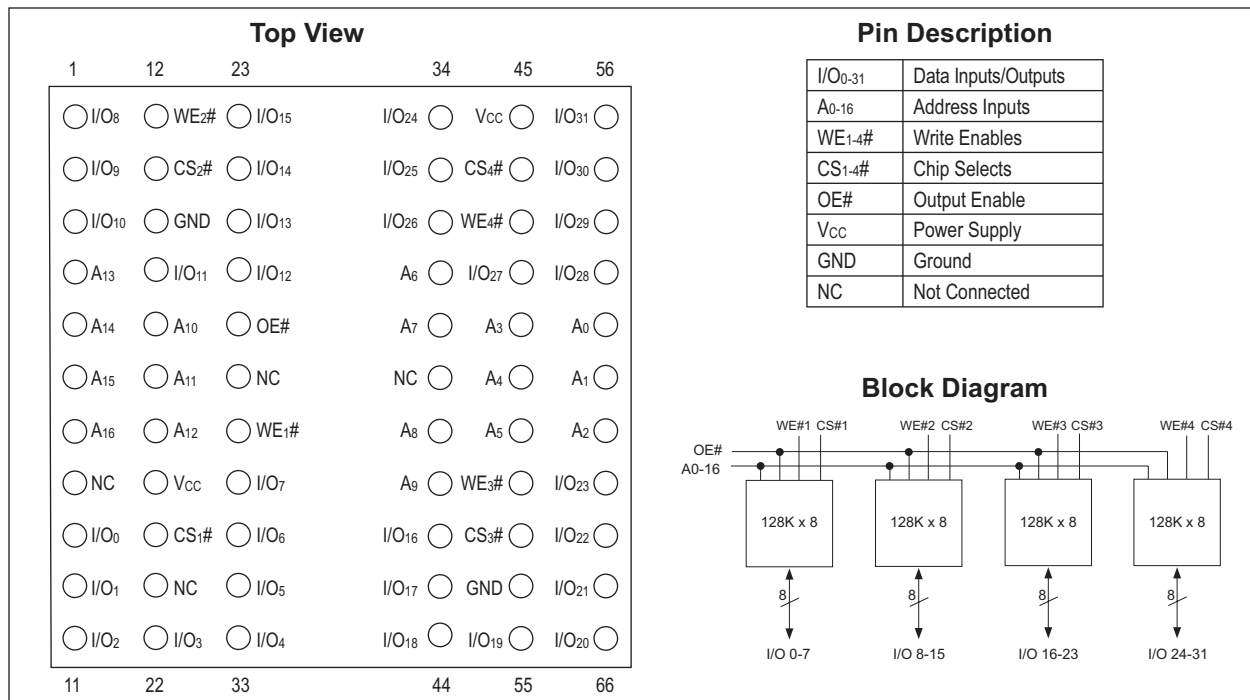

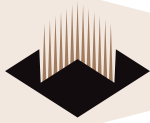

FIGURE 2 – PIN CONFIGURATION FOR WS128K32-XG4TX<sup>1</sup>

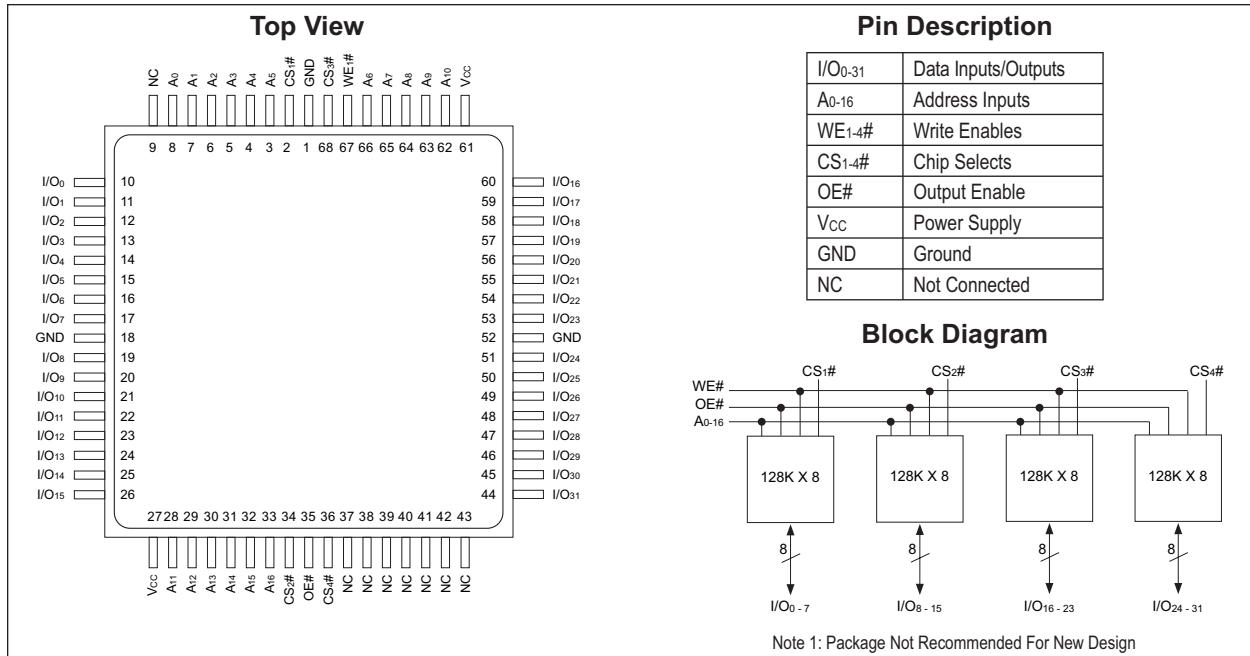
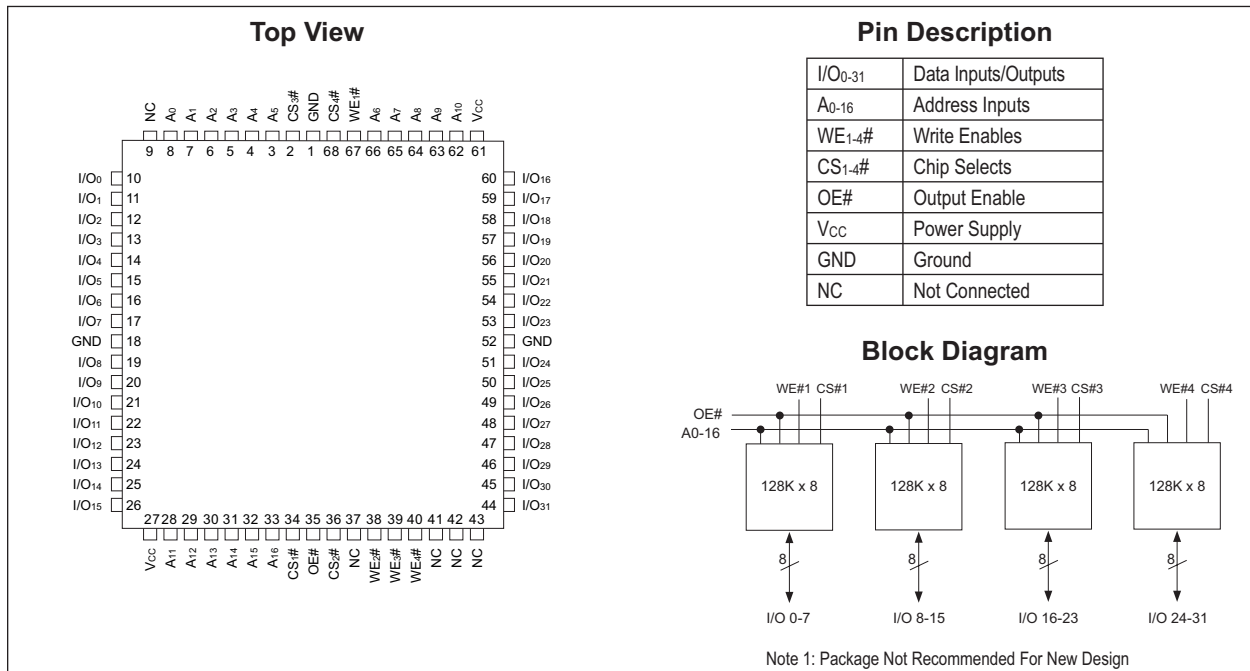
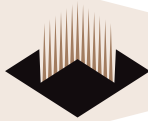

FIGURE 3 – PIN CONFIGURATION FOR WS128K32-XG2UX AND WS128K32-XG2LX





**ABSOLUTE MAXIMUM RATINGS**

Parameter	Symbol	Min	Max	Unit
Operating Temperature	T <sub>A</sub>	-55	+125	°C
Storage Temperature	T <sub>STG</sub>	-65	+150	°C
Signal Voltage Relative to GND	V <sub>G</sub>	-0.5	V <sub>CC</sub> +0.5	V
Junction Temperature	T <sub>J</sub>		150	°C
Supply Voltage	V <sub>CC</sub>	-0.5	7.0	V

**TRUTH TABLE**

CS	OE	WE	Mode	Data I/O	Power
H	X	X	Standby	High Z	Standby
L	L	H	Read	Data Out	Active
L	X	L	Write	Data In	Active
L	H	H	Out Disable	High Z	Active

**RECOMMENDED OPERATING CONDITIONS**

Parameter	Symbol	Min	Max	Unit
Supply Voltage	V <sub>CC</sub>	4.5	5.5	V
Input High Voltage	V <sub>IH</sub>	2.2	V <sub>CC</sub> + 0.3	V
Input Low Voltage	V <sub>IL</sub>	-0.5	+0.8	V
Operating Temp (Mil)	T <sub>A</sub>	-55	+125	°C

**CAPACITANCE**

T<sub>A</sub> = +25°C

Parameter	Symbol	Conditions	Max	Unit
OE# capacitance	C <sub>OE</sub>	V <sub>IN</sub> = 0V, f = 1.0 MHz	50	pF
WE1-4# capacitance HIP (PGA) H1 CQFP G4T CQFP G2U/G2L	C <sub>WE</sub>	V <sub>IN</sub> = 0V, f = 1.0 MHz	20 50 20	pF
CS1-4# capacitance	C <sub>CS</sub>	V <sub>IN</sub> = 0V, f = 1.0 MHz	20	pF
Data# I/O capacitance	C <sub>I/O</sub>	V <sub>I/O</sub> = 0V, f = 1.0 MHz	20	pF
Address input capacitance	C <sub>AD</sub>	V <sub>IN</sub> = 0V, f = 1.0 MHz	50	pF

This parameter is guaranteed by design but not tested.

**DC CHARACTERISTICS**

V<sub>CC</sub> = 5.0V, V<sub>SS</sub> = 0V, -55°C ≤ T<sub>A</sub> ≤ +125°C

Parameter	Sym	Conditions	-15		-17		-20		-25		Units
			Min	Max	Min	Max	Min	Max	Min	Max	
Input Leakage Current	I <sub>LI</sub>	V <sub>CC</sub> = 5.5, V <sub>IN</sub> = GND to V <sub>CC</sub>		10		10		10		10	µA
Output Leakage Current	I <sub>LO</sub>	CS# = V <sub>IH</sub> , OE# = V <sub>IH</sub> , V <sub>OUT</sub> = GND to V <sub>CC</sub>		10		10		10		10	µA
Operating Supply Current	I <sub>CC</sub>	CS# = V <sub>IL</sub> , OE# = V <sub>IH</sub> , f = 5MHz, V <sub>CC</sub> = 5.5		600		600		600		600	mA
Standby Current	I <sub>SB</sub>	CS# = V <sub>IH</sub> , OE# = V <sub>IH</sub> , f = 5MHz, V <sub>CC</sub> = 5.5		80		80		80		60	mA
Output Low Voltage	V <sub>OL</sub>	I <sub>OL</sub> = 8mA, V <sub>CC</sub> = 4.5		0.4		0.4		0.4		0.4	V
Output High Voltage	V <sub>OH</sub>	I <sub>OH</sub> = -4.0mA, V <sub>CC</sub> = 4.5	2.4		2.4		2.4		2.4		V

Parameter	Sym	Conditions	-35		-45		-55		Units
			Min	Max	Min	Max	Min	Max	
Input Leakage Current	I <sub>LI</sub>	V <sub>CC</sub> = 5.5, V <sub>IN</sub> = GND to V <sub>CC</sub>		10		10		10	µA
Output Leakage Current	I <sub>LO</sub>	CS# = V <sub>IH</sub> , OE# = V <sub>IH</sub> , V <sub>OUT</sub> = GND to V <sub>CC</sub>		10		10		10	µA
Operating Supply Current	I <sub>CC</sub>	CS# = V <sub>IL</sub> , OE# = V <sub>IH</sub> , f = 5MHz, V <sub>CC</sub> = 5.5		600		600		600	mA
Standby Current	I <sub>SB</sub>	CS# = V <sub>IH</sub> , OE# = V <sub>IH</sub> , f = 5MHz, V <sub>CC</sub> = 5.5		60		60		60	mA
Output Low Voltage	V <sub>OL</sub>	I <sub>OL</sub> = 8mA, V <sub>CC</sub> = 4.5		0.4		0.4		0.4	V
Output High Voltage	V <sub>OH</sub>	I <sub>OH</sub> = -4.0mA, V <sub>CC</sub> = 4.5	2.4		2.4		2.4		V

NOTE: DC test conditions: V<sub>IH</sub> = V<sub>CC</sub> - 0.3V, V<sub>IL</sub> = 0.3V

**DATA RETENTION CHARACTERISTICS (For WS128K32L-XXX Only)**

-55°C ≤ T<sub>A</sub> ≤ +125°C, -40°C ≤ T<sub>A</sub> ≤ +85°C

Characteristic	Sym	Conditions	Min	Typ	Max	Units
Data Retention Voltage	V <sub>CC</sub>	V <sub>CC</sub> = 2.0V	2	-	-	V
Data Retention Quiescent Current	I <sub>CCDR</sub>	CS# V <sub>CC</sub> - 0.2V	-	1	2	mA
Chip Disable to Data Retention Time (1)	T <sub>CDR</sub>	V <sub>IN</sub> = V <sub>CC</sub> - 0.2V	0	-	-	ns
Operation Recovery Time (1)	T <sub>R</sub>	or V <sub>IN</sub> 0.2V	TRC	-	-	ns

NOTE: Parameter guaranteed, but not tested.

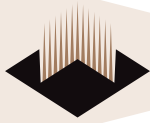

**AC CHARACTERISTICS**

V<sub>CC</sub> = 5.0V, GND = 0V, -55°C ≤ T<sub>A</sub> ≤ +125°C

Parameter	Symbol	-15		-17		-20		-25		-35		-45		-55		Units
		Min	Max	Min	Max	Min	Max	Min	Max	Min	Max	Min	Max	Min	Max	
Read Cycle Time	t <sub>RC</sub>	15		17		20		25		35		45		55		ns
Address Access Time	t <sub>AA</sub>		15		17		20		25		35		45		55	ns
Output Hold from Address Change	t <sub>OH</sub>	0		0		0		0		0		0		0		ns
Chip Select Access Time	t <sub>ACS</sub>		15		17		20		25		35		45		55	ns
Output Enable to Output Valid	t <sub>OE</sub>		10		10		12		15		20		25		30	ns
Chip Select to Output in Low Z	t <sub>CLZ</sub> <sup>1</sup>	3		3		3		3		3		3		3		ns
Output Enable to Output in Low Z	t <sub>OLZ</sub> <sup>1</sup>	0		0		0		0		0		0		0		ns
Chip Disable to Output in High Z	t <sub>CHZ</sub> <sup>1</sup>		12		12		12		12		15		20		20	ns
Output Disable to Output in High Z	t <sub>OHZ</sub> <sup>1</sup>		12		12		12		12		15		20		20	ns

1. This parameter is guaranteed by design but not tested.

**AC CHARACTERISTICS**

V<sub>CC</sub> = 5.0V, GND = 0V, -55°C ≤ T<sub>A</sub> ≤ +125°C

Parameter	Symbol	-15		-17		-20		-25		-35		-45		-55		Units
		Min	Max	Min	Max	Min	Max	Min	Max	Min	Max	Min	Max	Min	Max	
Write Cycle Time	t <sub>WC</sub>	15		17		20		25		35		45		55		ns
Chip Select to End of Write	t <sub>CW</sub>	14		14		15		20		25		30		45		ns
Address Valid to End of Write	t <sub>AW</sub>	14		15		15		20		25		30		45		ns
Data Valid to End of Write	t <sub>DW</sub>	10		10		12		15		20		25		25		ns
Write Pulse Width	t <sub>WP</sub>	14		14		15		20		25		30		45		ns
Address Setup Time	t <sub>AS</sub>	0		0		0		0		0		0		0		ns
Address Hold Time	t <sub>AH</sub>	0		0		0		0		0		0		0		ns
Output Active from End of Write	t <sub>OW</sub> <sup>1</sup>	3		3		3		3		4		4		4		ns
Write Enable to Output in High Z	t <sub>WHZ</sub> <sup>1</sup>		10		10		12		15		20		25		25	ns
Data Hold Time	t <sub>DH</sub>	0		0		0		0		0		0		0		ns

1. This parameter is guaranteed by design but not tested.

**FIGURE. 4 – AC TEST CIRCUIT**

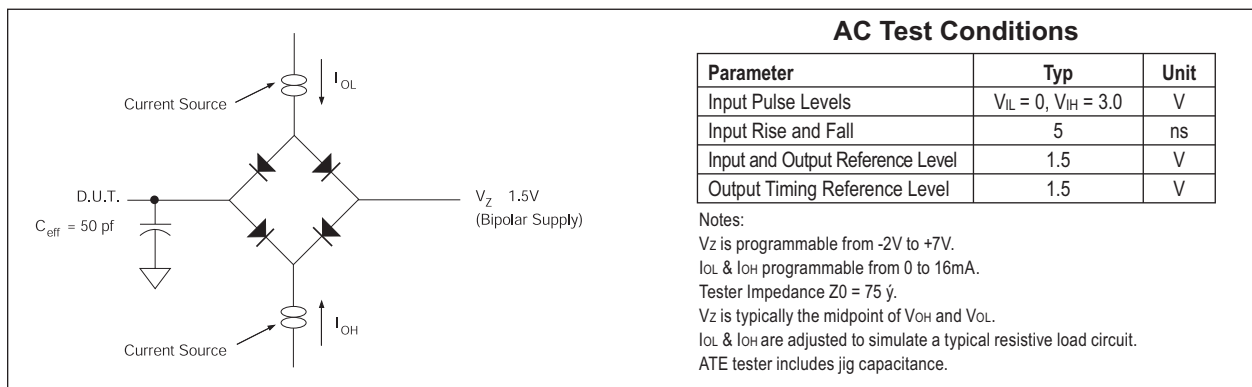

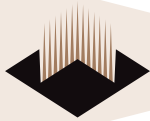

FIGURE 5 – TIMING WAVEFORM - READ CYCLE

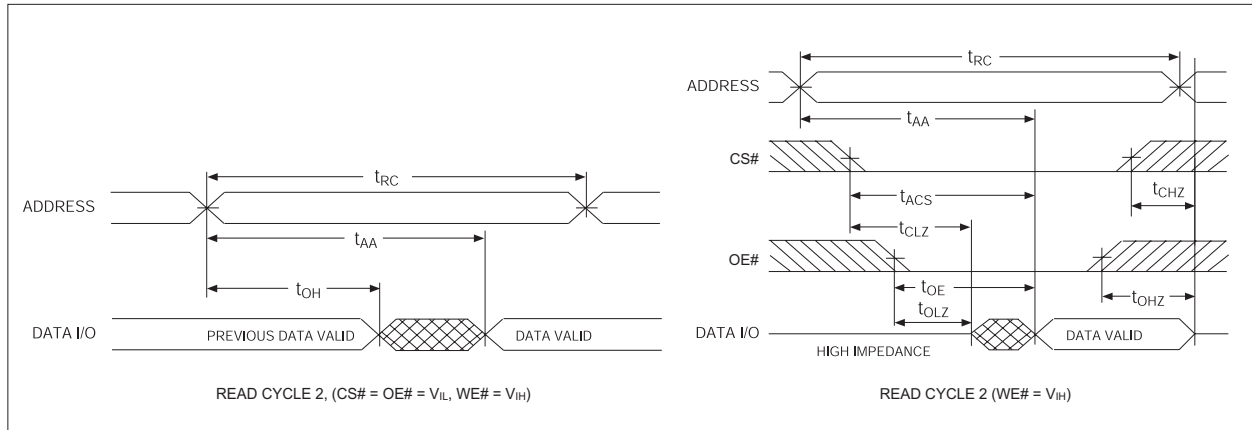

FIGURE 6 – WRITE CYCLE - WE# CONTROLLED

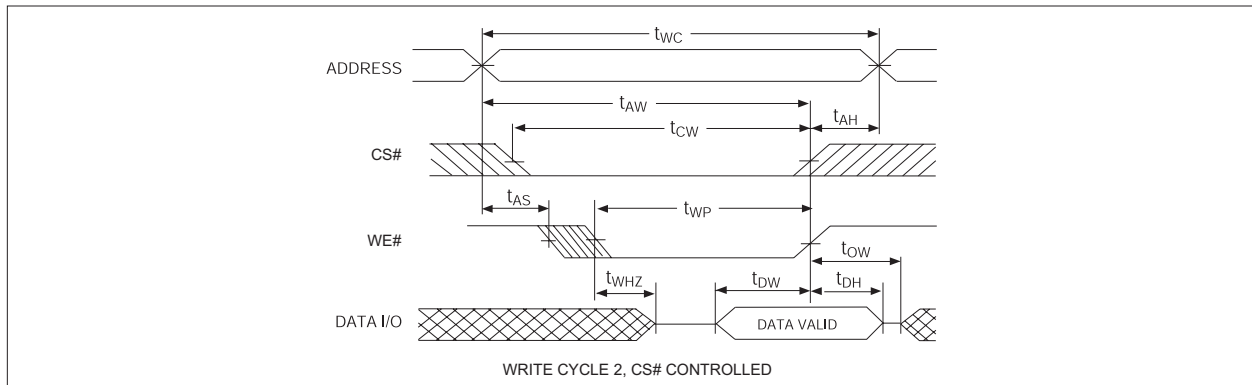
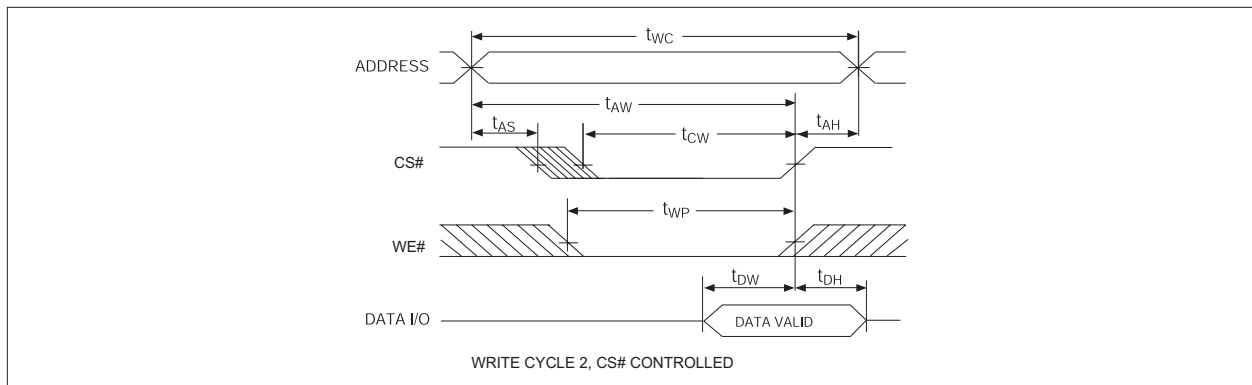
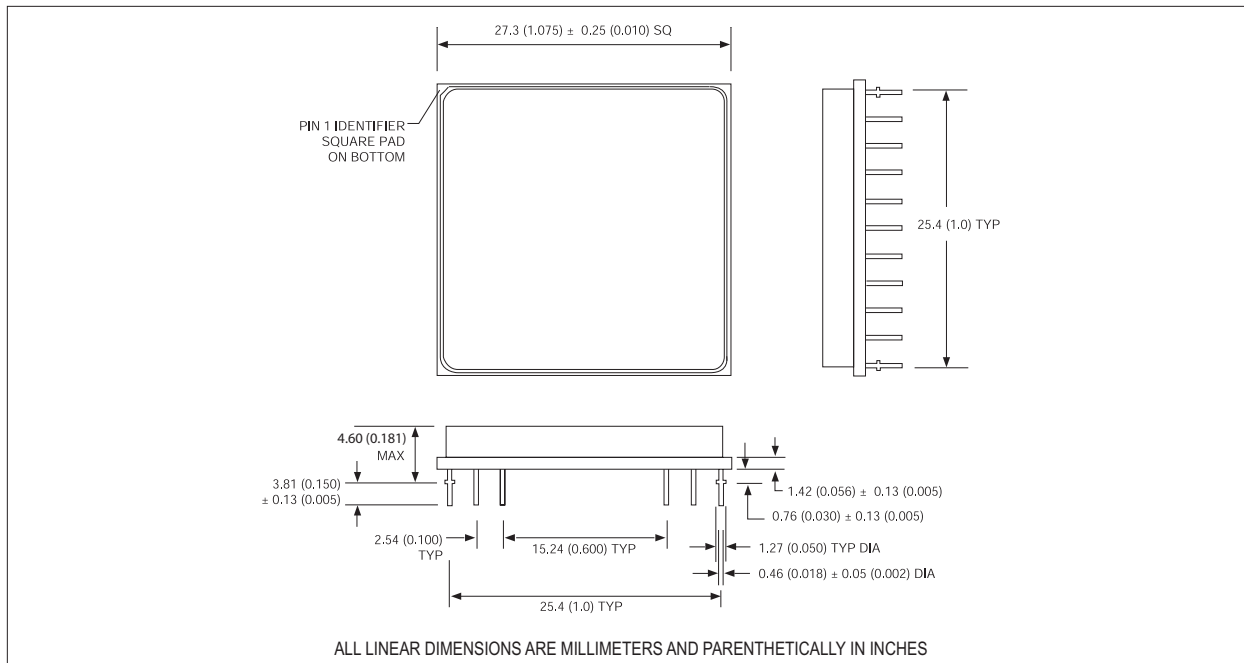

FIGURE 7 – WRITE CYCLE - CS# CONTROLLED





**PACKAGE 400: 66 PIN, PGA TYPE, CERAMIC HEX-IN-LINE PACKAGE, HIP (H1)**



**PACKAGE 502: 68 LEAD, CERAMIC QUAD FLAT PACK, LOW PROFILE CQFP (G4T)<sup>1</sup>**

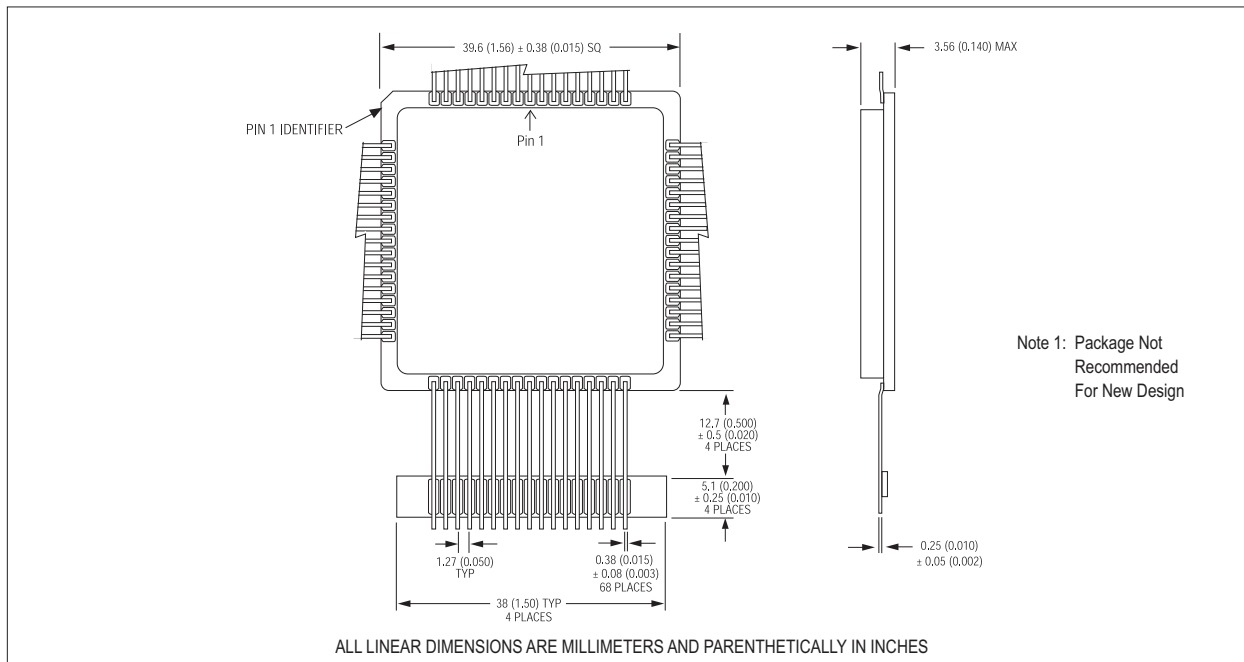

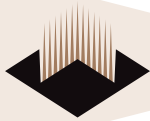

PACKAGE 510: 68 LEAD, CERAMIC QUAD FLAT PACK, CQFP (G2U)

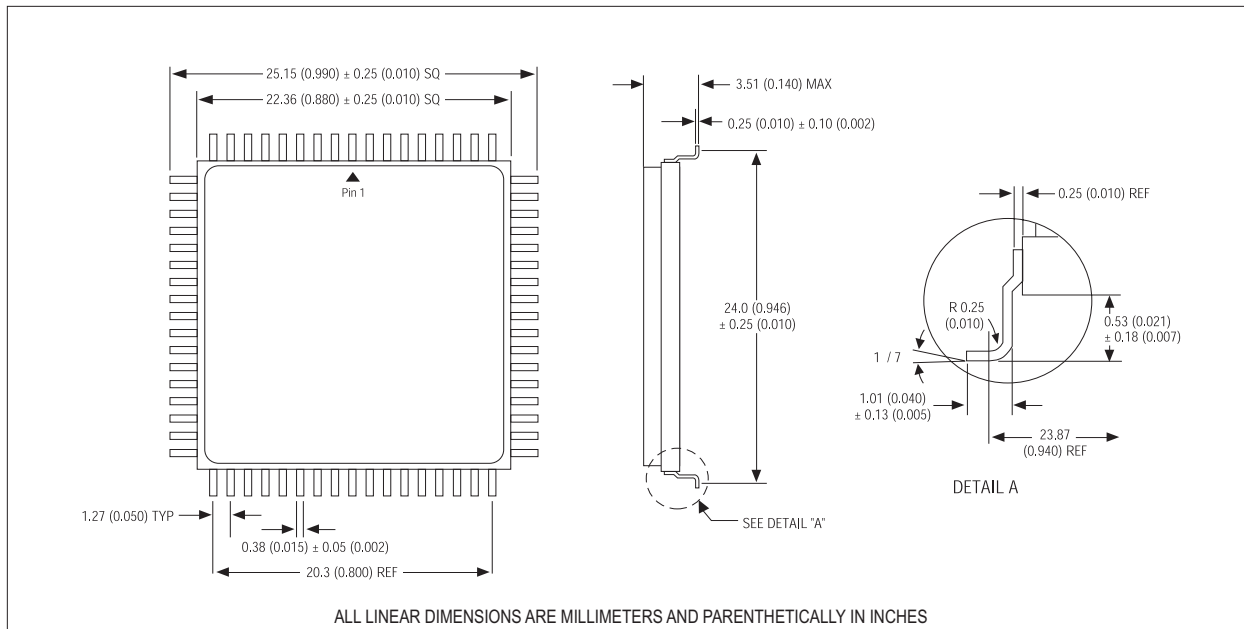

PACKAGE 528: 68 LEAD, CERAMIC QUAD FLAT PACK, CQFP (G2L)

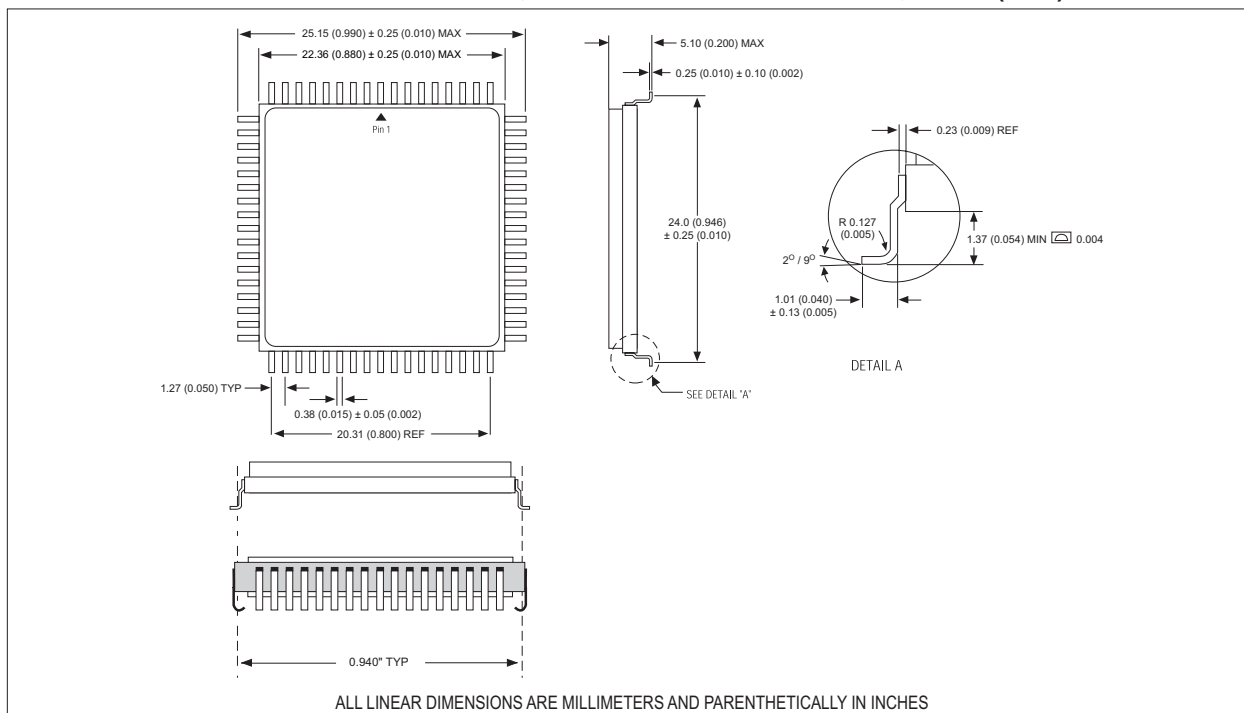



**ORDERING INFORMATION**

**W S 128K 32 X - XXX X X X**

**LEAD FINISH:**

Blank = Gold plated leads

A = Solder dip leads

**DEVICE GRADE:**

Q = MIL-STD-883 Compliant

M = Military Screened -55°C to +125°C

I = Industrial -40°C to +85°C

C = Commercial 0°C to +70°C

**PACKAGE TYPE:**

H1 = 1.075" sq. Ceramic Hex-In-line Package, HIP (Package 400)

G2U = 22.4mm Ceramic Quad Flat Pack, CQFP (Package 510)

G2L = 22.4mm Ceramic Quad Flat Pack, CQFP (Package 528)

G4T<sup>1</sup> = 40 mm Low Profile CQFP (Package 502)

**ACCESS TIME (ns)**

**IMPROVEMENT MARK:**

N = No Connect at pin 8, 21, 28 and 39 in HIP for Upgrades

L = Low Power\*

**ORGANIZATION, 128Kx32**

User configurable as 256Kx16 or 512Kx8

**SRAM**

**WHITE ELECTRONIC DESIGNS CORPORATION**

Note 1: Package Not Recommended For New Designs

\* Low Power Data Retention only available in G2U, G2L, PackageTypes

