

AN7328K

Pre-settable Equalizer IC for Radio-Cassette

■ Overview

The AN7328K is an IC designed for radio cassette equalizers with five preset modes making it possible to select one of the five frequency response characteristics. By using this IC as the prestage circuit of an output amplifier, audio output with optimum tone characteristics according to rock, pop, flat, jazz, or classical music is obtained.

■ Features

- Equalizer characteristics with peaking audio frequencies of 100 Hz and 7 kHz are available in five different modes
- The rock mode is automatically selected as a default setting
- Microcomputer control possible
- Low operating voltage (Supply voltage : 3.6 V min.)

■ Applications

- Stereo radio cassette recorder with built-in CD player
- Portable stereo set

■ Block Diagram

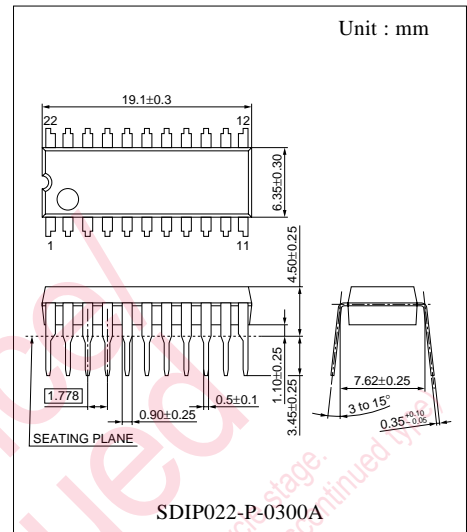
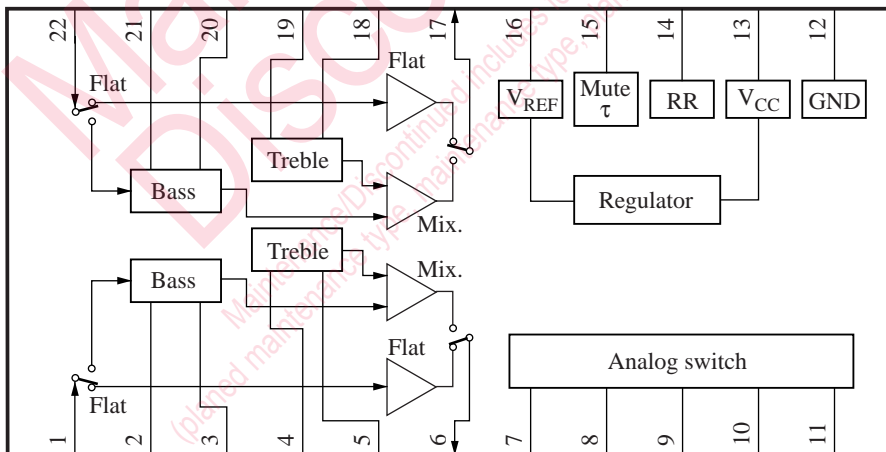

■ Pin Descriptions

Pin No.	Description	Pin No.	Description
1	R-ch. input	12	GND
2	R-ch. negative feedback 1	13	V _{CC}
3	R-ch. bass	14	Ripple rejection
4	R-ch. treble	15	Mute τ
5	R-ch. negative feedback 2	16	Reference voltage
6	R-ch. output	17	L-ch. output
7	Classic	18	L-ch. negative feedback 2
8	Rock	19	L-ch. treble
9	Jazz	20	L-ch. bass
10	Pops	21	L-ch. negative feedback 1
11	Flat	22	L-ch. input

■ Absolute Maximum Ratings

Parameter	Symbol	Ratings	Unit
Supply voltage	V _{CC}	14	V
Supply current	I _{CC}	50	mA
Power dissipation	P _D	700	mW
Operating ambient temperature *	T _{opr}	-25 to +75	°C
Storage temperature *	T _{stg}	-55 to +150	°C

Note) * : Except these items, all other measurements are taken at T_a = 25 °C.

■ Recommended Operating Range

Parameter	Symbol	Range	Unit
Supply voltage	V _{CC}	3.6 to 12	V

■ Electrical Characteristics at $V_{CC} = 6\text{ V}$, freq. = 1 kHz, $T_a = 25\text{ }^\circ\text{C}$, Flat mode, unless otherwise specified

Parameter	Symbol	Conditions	Min	Typ	Max	Unit
Quiescent current	I_{CQ1}	No input	10.5	15.0	19.5	mA
Channel balance	CB	$V_{INL} = 0.1\text{ V}$, $V_{INR} = 0.1\text{ V}$	-1	0	1	dB
Reference voltage	V_{REF}	No input	2.4	3.4	4.3	V
Ripple rejection	RR	$V_R = 0.1\text{ V}$, $f_R = 100\text{ Hz}$	35	40	—	dB
Channel separation	CS	$V_{IN} = 0.1\text{ V}$, Measure V_{OUT}	35	40	—	dB
Output noise *	V_{NO}	$V_{IN} = 0\text{ V}$, $R_G = 2.2\text{ k}\Omega$	—	10	20	μV
THD (1 kHz) *	THD1	$V_{IN} = 0.1\text{ V}$	—	0.1	0.3	%
Gain (100 Hz)	G_{V1}	$V_{IN} = 0.1\text{ V}$	-2.0	-0.5	2.0	dB
Gain (7 kHz)	G_{V2}	$V_{IN} = 0.1\text{ V}$	-2.0	0.5	2.0	dB
Maximum output voltage	V_{OM}	THD = 1%, $R_L = 10\text{ k}\Omega$	0.6	1.0	1.4	V_{rms}
Channel (Classic)						
Quiescent current	I_{CQ2}	No input	11.5	16.0	20.5	mA
Gain (100 Hz)	G_{V3}	$V_{IN} = 0.1\text{ V}$	2	4	6	dB
Gain (7 kHz)	G_{V4}	$V_{IN} = 0.1\text{ V}$	2	4	6	dB
Channel (Rock)						
Quiescent current	I_{CQ3}	No input	10.5	14.5	19.0	mA
Gain (100 Hz)	G_{V5}	$V_{IN} = 0.1\text{ V}$	6	8	10	dB
Gain (7 kHz)	G_{V6}	$V_{IN} = 0.1\text{ V}$	6	8	10	dB
Channel (Jazz)						
Quiescent current	I_{CQ4}	No input	10.5	14.5	19.0	mA
Gain (100 Hz)	G_{V7}	$V_{IN} = 0.1\text{ V}$	6	8	10	dB
Gain (7 kHz)	G_{V8}	$V_{IN} = 0.1\text{ V}$	2	4	6	dB
Channel (Pops)						
Quiescent current	I_{CQ5}	No input	10.5	14.5	19.5	mA
Gain (100 Hz)	G_{V9}	$V_{IN} = 0.1\text{ V}$	2	4	6	dB
Gain (7 kHz)	G_{V10}	$V_{IN} = 0.1\text{ V}$	6	8	10	dB
Channel (Classic)						
THD (1 kHz) *	THD2	$V_{IN} = 0.1\text{ V}$	—	0.25	0.3	%
Channel (Rock)						
THD (1 kHz) *	THD3	$V_{IN} = 0.1\text{ V}$	—	0.25	0.3	%
Channel (Jazz)						
THD (1 kHz) *	THD4	$V_{IN} = 0.1\text{ V}$	—	0.25	0.3	%
Channel (Pops)						
THD (1 kHz) *	THD5	$V_{IN} = 0.1\text{ V}$	—	0.25	0.3	%

Note) * : DIN audio filter used

■ Terminal Equivalent Circuits

Pin No.	Equivalent Circuit	Description	DC Bias (V)
1		<p>Bass input for R-ch. : These are the inputs to the IC. These inputs can be from PRE or VOL block, through a 0.47 μF cap.</p> <p>I/P impedance \approx 5.8 kΩ</p>	3.40
2 3		<p>Negative feedback pin & Pass filter pin : C_F and R_{IN} form a low pass filter and its cutoff frequency can be changed by varying C_F.</p> <p>G_V can be changed by varying R_{IN} externally.</p>	3.40
4	<p>Refer to Pin 1</p>	<p>Treble input for R-ch. : The output signal of previous stage will go through a filtering network before input to this pin.</p> <p>Impedance \approx decided by the filter network.</p> <p>NB : Peak frequency can be changed by varying capacitor value.</p>	3.40

■ Terminal Equivalent Circuits (continued)

Pin No.	Equivalent Circuit	Description	DC Bias (V)
5		<p>Negative feedback pin for Treble : G_V can be changed by varying R_{IN} externally.</p>	3.40
6		<p>Output pin for R-ch. : Pushpull output pin for connecting to the next stage through a coupling capacitor. $Z_{OUT} \approx 75 \Omega$</p>	3.40
7 8 9 10 11		<p>Analog Switch : Switch pin for Rock,Pops,Jazz,Classic & Flat,with initial mode set at Rock mode. The current source circuit provides the ability to drive the LED indicators. The average current is about 2 mA. If the LED indicators need more than 2 mA, additional transistor is needed. Please refer to the application notes. Selected mode has a bias of 2.45 V & other pins have bias of 0 V.</p>	2.45 or 0
12	—	GND	0.00
13	—	V_{CC}	6.00

■ Terminal Equivalent Circuits (continued)

Pin No.	Equivalent Circuit	Description	DC Bias (V)
14		<p>Ripple Rejection :</p> <p>To connect with a capacitor to minimize ripple generated from V_{CC} source.</p>	5.00
15		<p>Mute τ :</p> <p>To connect with a capacitor to mute pop noise.</p> <p>The time constant of the mute pulse may be changed by varying C_{SD}.</p>	1.60
16		<p>Reference Voltage :</p> <p>Provide fixed DC bias, which is slightly above $1/2 V_{CC}$ to allow for bigger dynamic range.</p>	3.40
17	Refer to Pin6	Output pin for L-ch. : Refer to Pin6	3.40
18	Refer to Pin5	Negative feedback pin for Treble : Refer to Pin5	3.40
19	Refer to Pin4	Treble input for L-ch. : Refer to Pin4	3.40
20	Refer to Pin2	Negative feedback pin & Pass filter pin : Refer to Pin2	3.40
21	Refer to Pin2	Negative feedback pin & Pass filter pin : Refer to Pin2	3.40
22	Refer to Pin1	Bass input for L-ch. : Refer to Pin1	3.40

■ Application Note

• Preset graphic equaliser

This IC provides 5 preset modes by means of 5 push button switches, with built-in LED indicator. The boosting frequencies are 100 Hz and 7 kHz.

A) Rock

By pressing this switch, both 100 Hz and 7 kHz signal are boosted by 8 dB.

This is the initial preset mode, i.e. when V_{CC} is turn ON, this mode will be ON automatically.

B) Pops

This preset mode will boost 100 Hz signal by 4 dB and 7 kHz signal by 8 dB.

C) Flat

There is a built-in buffer for this mode to pass the signal directly to output without processing.

D) Classic

This mode will boost both 100 Hz and 7 kHz signal by 4 dB.

E) Jazz

This preset mode will boost 100 Hz signal by 8 dB and 7 kHz signal by 4 dB.

• Frequency response curve

	100 Hz	7 kHz	Response curve
Rock	+ 8 dB	+ 8 dB	
Pops	+ 4 dB	+ 8 dB	
Flat	—	—	
Classic	+ 4 dB	+ 4 dB	
Jazz	+ 8 dB	+ 4 dB	

■ Application Note (continued)

- Interfacing with microcomputer

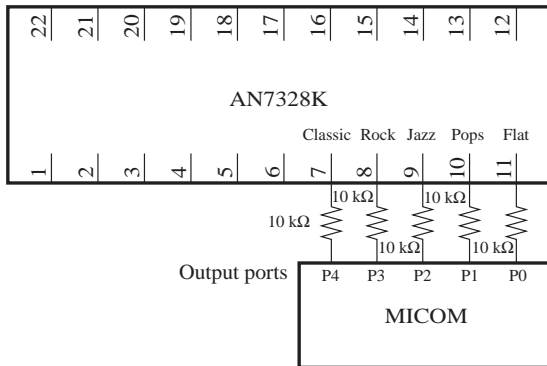

MICOM O/P					Selected mode
P4	P3	P2	P1	P0	
L	L	L	L	H	Flat
L	L	L	H	L	Pops
L	L	H	L	L	Jazz
L	H	L	L	L	Rock
H	L	L	L	L	Classic

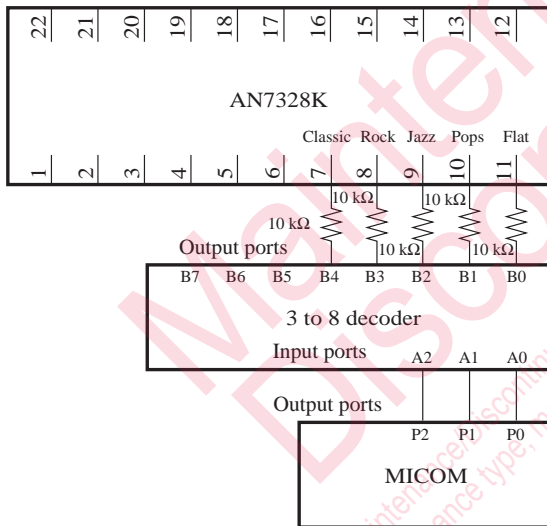

MICOM O/P			Decoder O/P					Selected mode
P2	P1	P0	B4	B3	B2	B1	B0	
L	L	L	L	L	L	L	H	Flat
L	L	H	L	L	L	H	L	Pops
L	H	L	L	L	H	L	L	Jazz
L	H	H	L	H	L	L	L	Rock
H	L	L	H	L	L	L	L	Classic

■ Application Note (continued)

1. This IC has two peak frequencies (100 Hz & 7 kHz) which can be adjusted by varying external component value. Below is a table of gain, frequency shift vs external component value.

	Peak freq. (100 Hz)		Peak freq. (7 kHz)		Low freq. gain		High freq. gain	
	Increase	Decrease	Increase	Decrease	Increase	Decrease	Increase	Decrease
RL ₁	—	—	↓	↑	—	—	↑	↓
RL ₂	—	—	—	—	—	—	↓	↑
RL ₃	—	—	—	—	↓	↑	—	—
RL ₄	—	—	↓	↑	—	—	↓	↑
CL ₁	—	—	↓	↑	—	—	↓	↑
CL ₂	—	—	—	—	↑	↓	—	—
CL ₃	—	—	↓	↑	—	—	↑	↓
CL ₄	↓	↑	—	—	—	—	—	—

↑ Increase component value and ↓ Decrease component value

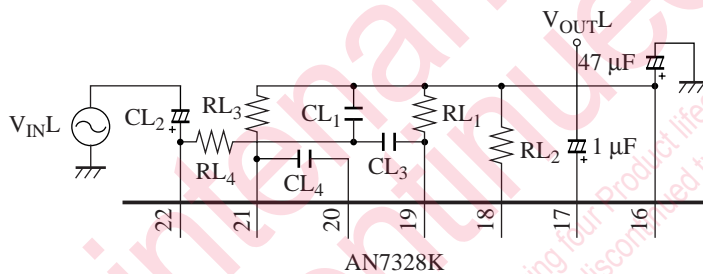

2. If the previous stage has high output impedance (Z_{OUT}), this may cause the output drop at high frequency. In this situation, the following circuit is recommended to improve the high frequency performance.

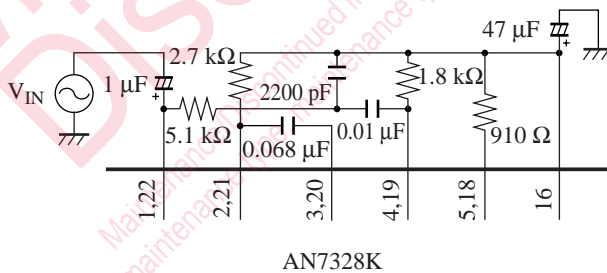

■ Application Note (continued)

Interfacing with LED indicators whose the current exceed 2 mA.

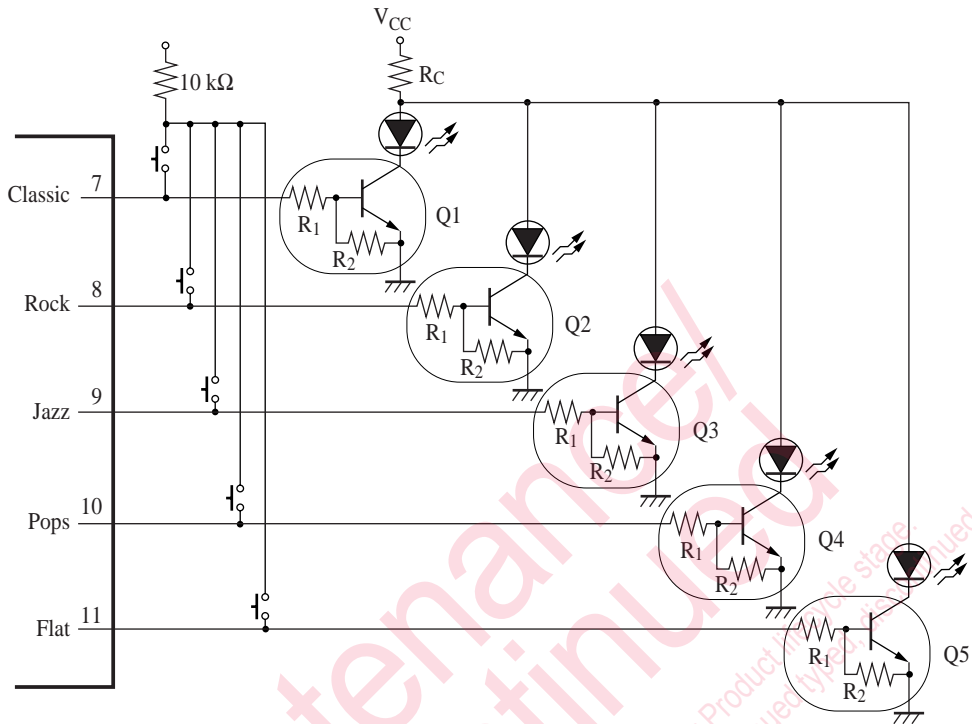

Transistor	Built-in resistor	Electrical characteristics
Q2 (Rock)	R ₁ = 10 kΩ R ₂ = 10 kΩ	I _C = 100 mA h _{FE} = 35 (min.) to 100 (max.)
Q1 (Classic) Q3 (Jazz) Q4 (Pops) Q5 (Flat)	R ₁ = 4.7 kΩ R ₂ = 10 kΩ	I _C = 100 mA h _{FE} = 35 (min.) to 100 (max.)

e.g. R_C = 390 Ω
 Pin voltage to turn on LED is ≈ 2.5 V.
 V_{LED} = 2.68 V, LED current ≈ 13 mA

Request for your special attention and precautions in using the technical information and semiconductors described in this book

- (1) If any of the products or technical information described in this book is to be exported or provided to non-residents, the laws and regulations of the exporting country, especially, those with regard to security export control, must be observed.
- (2) The technical information described in this book is intended only to show the main characteristics and application circuit examples of the products, and no license is granted under any intellectual property right or other right owned by our company or any other company. Therefore, no responsibility is assumed by our company as to the infringement upon any such right owned by any other company which may arise as a result of the use of technical information described in this book.
- (3) The products described in this book are intended to be used for standard applications or general electronic equipment (such as office equipment, communications equipment, measuring instruments and household appliances).
Consult our sales staff in advance for information on the following applications:
 - Special applications (such as for airplanes, aerospace, automobiles, traffic control equipment, combustion equipment, life support systems and safety devices) in which exceptional quality and reliability are required, or if the failure or malfunction of the products may directly jeopardize life or harm the human body.
 - Any applications other than the standard applications intended.
- (4) The products and product specifications described in this book are subject to change without notice for modification and/or improvement. At the final stage of your design, purchasing, or use of the products, therefore, ask for the most up-to-date Product Standards in advance to make sure that the latest specifications satisfy your requirements.
- (5) When designing your equipment, comply with the range of absolute maximum rating and the guaranteed operating conditions (operating power supply voltage and operating environment etc.). Especially, please be careful not to exceed the range of absolute maximum rating on the transient state, such as power-on, power-off and mode-switching. Otherwise, we will not be liable for any defect which may arise later in your equipment.
 - Even when the products are used within the guaranteed values, take into the consideration of incidence of break down and failure mode, possible to occur to semiconductor products. Measures on the systems such as redundant design, arresting the spread of fire or preventing glitch are recommended in order to prevent physical injury, fire, social damages, for example, by using the products.
- (6) Comply with the instructions for use in order to prevent breakdown and characteristics change due to external factors (ESD, EOS, thermal stress and mechanical stress) at the time of handling, mounting or at customer's process. When using products for which damp-proof packing is required, satisfy the conditions, such as shelf life and the elapsed time since first opening the packages.
- (7) This book may be not reprinted or reproduced whether wholly or partially, without the prior written permission of Matsushita Electric Industrial Co., Ltd.