

EC29 Series

- RoHS Compliant (Pb-Free)
- LVHCMOS output
- 1.8V Supply Voltage
- Ceramic SMD package
- Stability to 20ppm
- Standby Function
- Available on Tape and Reel

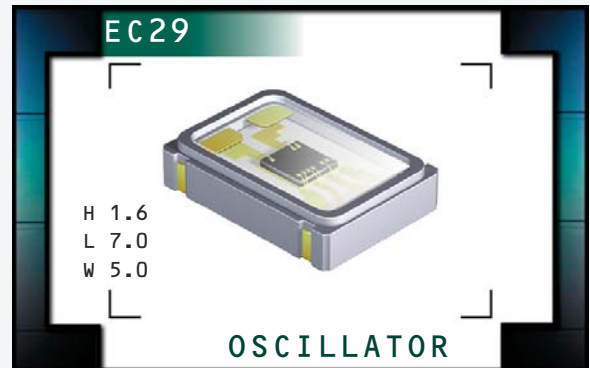

ECLIPTEK[®]
CORPORATION



ELECTRICAL SPECIFICATIONS

Frequency Range (F_0) 1.544MHz to 80.000MHz and 98.304MHz, 100.000MHz, 106.250MHz, 110.000MHz, 125.000MHz

Operating Temperature Range (OTR) 0°C to 70°C
-40°C to 85°C

Storage Temperature Range (STR) -55°C to 125°C

Supply Voltage (V_{DD}) 1.8V_{DC} ±5%

Input Current (I_{DD})	1.544MHz to 10.000MHz	2mA Maximum
	10.001MHz to 25.000MHz	3mA Maximum
	25.001MHz to 40.000MHz	4mA Maximum
	40.001MHz to 50.000MHz	8mA Maximum
	50.001MHz to 70.000MHz	10mA Maximum
	70.001MHz to 100.000MHz	18mA Maximum
	100.001MHz to 110.000MHz	20mA Maximum
110.001MHz to 125.000MHz	25mA Maximum	

Frequency Tolerance/Stability Inclusive of all conditions: Calibration Tolerance at 25°C, ±100ppm, ±50ppm, ±25ppm, or
Frequency Stability over the Operating Temperature Range, Supply Voltage Change, Output Load Change, ±20ppm
First Year Aging at 25°C, Shock, and Vibration

Output Voltage Logic High (V_{OH})	$I_{OH} = -2.8mA$, 1.544MHz to 40.000MHz	90% of V_{DD} Minimum
	$I_{OH} = -8mA$, 40.001MHz to 125.000MHz	90% of V_{DD} Minimum

Output Voltage Logic Low (V_{OL})	$I_{OL} = 2.8mA$, 1.544MHz to 40.000MHz	10% of V_{DD} Maximum
	$I_{OL} = 8mA$, 40.001MHz to 125.000MHz	10% of V_{DD} Maximum

Rise Time / Fall Time (T_R/T_F)	< 40.000MHz 10% to 90% of Waveform	6 nSeconds Maximum
	≥ 40.000MHz 10% to 90% of Waveform	3 nSeconds Maximum

Duty Cycle (SYM)	at 50% of Waveform	50 ±10(%) (Standard)
	at 50% of Waveform	50 ±5(%) (Optional)

Load Drive Capability (C_{LOAD}) 15pF HCMOS Load Maximum

Tri-State Input Voltage	No Connection	Enables Output
	$V_{IH} \geq 90\%$ of V_{DD}	Enables Output
	$V_{IL} \leq 10\%$ of V_{DD}	Disables Output: High Impedance

Standby Current	Disabled Output: High Impedance, 1.544MHz to 40MHz	10µA Maximum
	Disabled Output: High Impedance, 40.001MHz to 70MHz	100µA Maximum
	Disabled Output: High Impedance, 70.001MHz to 125MHz	10µA Maximum

Start Up Time (T_S) 10 mSeconds Maximum

Period Jitter: Absolute ±100pSeconds Maximum

Period Jitter: One Sigma ±25pSeconds Maximum

MANUFACTURER
ECLIPTEK CORP.

CATEGORY
OSCILLATOR

SERIES
EC29

PACKAGE
CERAMIC

VOLTAGE
1.8V

CLASS
OS1B

REV. DATE
01/05

PART NUMBERING GUIDE

EC29 00 ET TTS - 30.000M TR

FREQUENCY TOLERANCE / STABILITY

00=±100ppm Maximum (Standard)
 45=±50ppm Maximum, 25=±25ppm Maximum
 20=±20ppm Maximum

OPERATING TEMPERATURE RANGE

Blank=0°C to 70°C (Standard)
 ET=-40°C to 85°C

PACKAGING OPTIONS

Blank=Bulk (Standard)
 TR=Tape and Reel

FREQUENCY

DUTY CYCLE

Blank=50 ±10(%) (Standard)
 T=50 ±5(%)

MECHANICAL DIMENSIONS

ALL DIMENSIONS IN MILLIMETERS

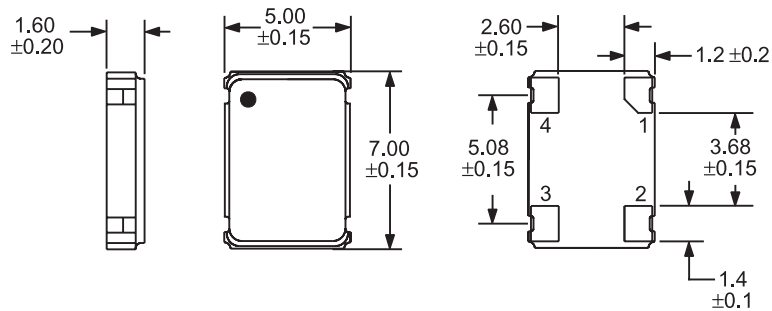

SUGGESTED SOLDER PAD LAYOUT

ALL DIMENSIONS IN MILLIMETERS

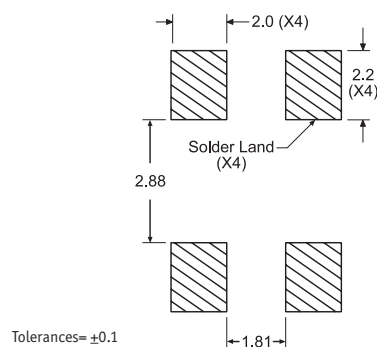

TAPE AND REEL DIMENSIONS

ALL DIMENSIONS IN MILLIMETERS

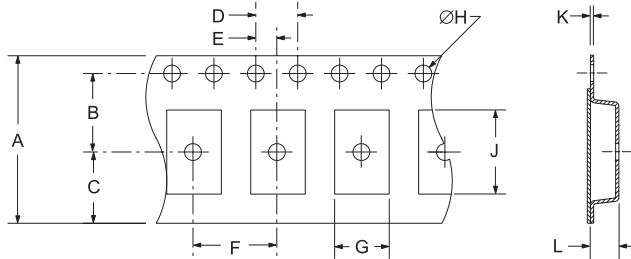

TAPE	A	B	C	D	E
	16±.3-.1	7.5±.1	6.75±.1	4 ±.1	2±.1
F	G	H	J	K	L
8±.1	B0*	1.5 ±.1-0	A0*	.3 ±.05	K0*

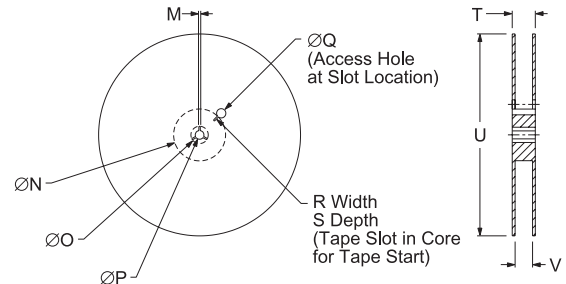

REEL	M	N	O	P	Q
	1.5 MIN	50 MIN	20.2 MIN	13±.2	40 MIN
R	S	T	U	V	QTY/REEL
2.5 MIN	10 MIN	22.4 MAX	360 MAX	16.4±2-0	1,000

*Compliant to EIA 481A

ENVIRONMENTAL/MECHANICAL SPECIFICATIONS

Characteristic

Fine Leak Test
 Gross Leak Test
 Mechanical Shock
 Vibration
 Solderability
 Temperature Cycling
 Resistance to Soldering Heat
 Resistance to Solvents

Specification

MIL-STD-883, Method 1014, Condition A
 MIL-STD-883, Method 1014, Condition C
 MIL-STD-202, Method 213, Condition C
 MIL-STD-883, Method 2007, Condition A
 MIL-STD-883, Method 2002
 MIL-STD-883, Method 1010
 MIL-STD-202, Method 210
 MIL-STD-202, Method 215

MARKING SPECIFICATIONS

Line 1: ECLIPTEK

Line 2: XX.XXX M

Frequency in MHz (5 Digits Maximum + Decimal)

Line 3: XXY ZZ

Week of Year
 Last Digit of Year
 Ecliptek Manufacturing Identifier

MANUFACTURER	CATEGORY	SERIES	PACKAGE	VOLTAGE	CLASS	REV. DATE
ECLIPTEK CORP.	OSCILLATOR	EC29	CERAMIC	1.8V	OS1B	01/05