

TC9804P

TENTATIVE DATA

TC9804P is a 24-pin CMOS programmable logic device (PLD) based on EEPROM cells. It has a zero-standby function. Designed using Toshiba's original technology, this device features low power dissipation and a wide operating voltage range (2V to 5.25V), and is applicable to a variety of electronic devices.

It has both AND and OR arrays which the user can program like a field programmable logic array (FPLA). TC9804P consists of four blocks divided into macro cells made up of 2-bit memory cells containing D-type flip/flops (registers). Sync operation is implemented in units of blocks with up to four clocks.

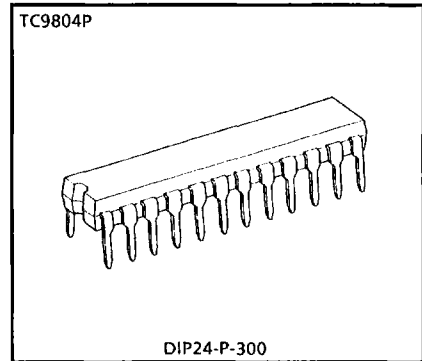

Weight : 1.50g (Typ.)

FEATURES

- Architecture 84 AND terms
16 OR terms
16 macro cells with registers
(Set/reset in async enable)
- Security cell Protection of proprietary information
- Signature word 84 bits for user ID code or inventory control
- High speed operation t_{pD} (input-output) = 33ns (Typ.)
 t_{cO} (clock-output) = 8ns (Typ.)
- Low power dissipation I_{CC} (standby) = 4 μ A (max. @25°C)
- Wide operating voltage range V_{CC} = 2~5.25V
- Programmable clock 1-4 clock pins
- Package 24-pin plastic DIP

TC9804P

PIN NAMES & FUNCTIONS

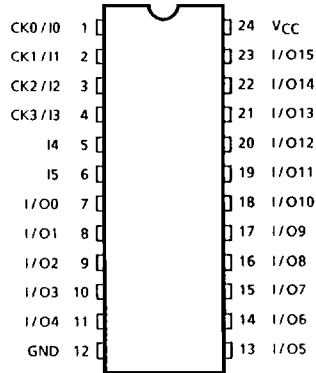

- CK0 / I0 ~ CK3 / I3 Clock input (when register is selected)
- 14, 15 Dedicated to input
- I / O0 ~ I / O15 Input / Output (with register output)

FUNCTION DIAGRAM

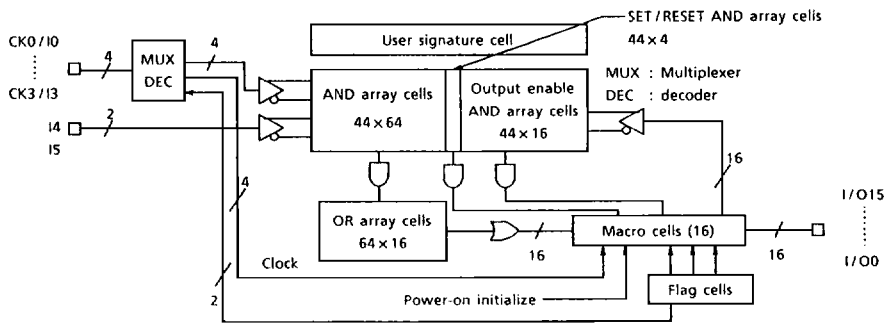

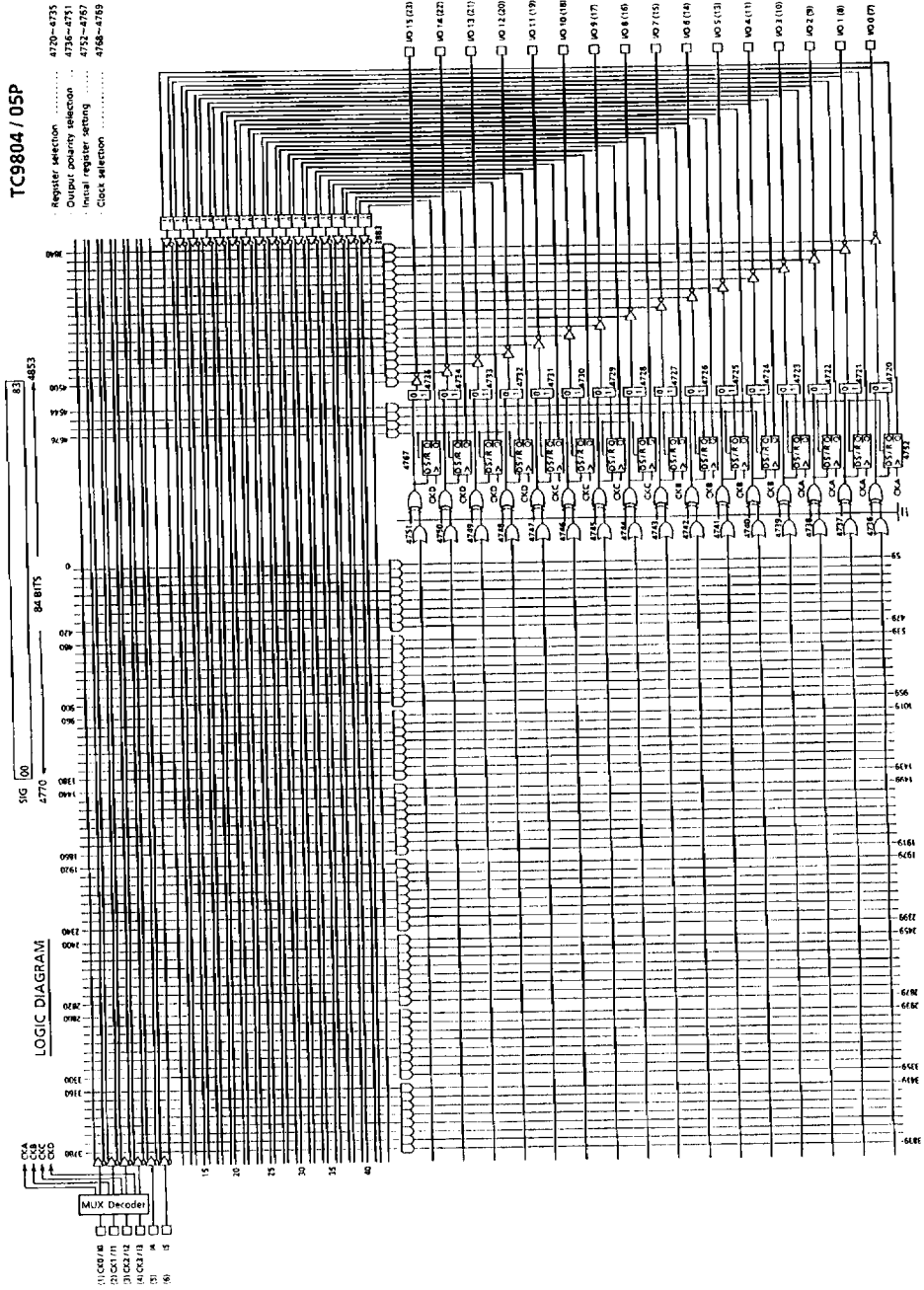

ARCHITECTURE

1. MEMORY CELLS

Programmable memory cells are divided into the following six types : AND array, OR array, output control array, flag, user signature, and register set/reset control array.

Setting program data to 1 disconnects signals to an AND/OR array : setting to 0 connects.

(1) AND array (44 × 64)

Total of 84 product terms (64 AND terms, 16 output control terms, and 4 register set / reset control terms)

(2) OR array (64 × 16)

64 AND terms input to 16 OR terms.

(3) Output control array (44 × 16)

Output from this array enables CMOS output (I/O0~I/O15).

(4) Register set/reset control array (44 × 4)

16 macro cells with D-type flip/flops are divided into four blocks. AND terms are provided with each block. Any input pin can be set to sync set/reset for a block. When the AND output of signals input to this cell array becomes high, initial states for registers are set.

(5) Flag cell

- A. Output polarity selection cell 16 bits
- B. Register selection cell 16 bits
- C. Initial register setting cell 16 bits
- D. Security cell 1 bit
- E. Clock select cell 2 bits

(6) User signature cell

User can program a 84-bit memory array for a variety of uses including ID codes, inventory control, and revision number.

Programming the security bit (security cell) disables access of cells other than the signature cell.

2. Macro cells

TC9804 has 16 macro cells containing D-type flip / flops (register).

(1) Output polarity of OR array

Sixteen exclusive OR gates control the output polarity of the OR array. These gates are user programmable : setting program data to 1 inputs the output signal from the OR array as inverted ; setting program data to 0, as non-inverted.

(2) Register selection

The sixteen output registers can be independently selected. Setting the program data to 1 selects an output register ; setting to 0 does not select an output register. When an output register is selected, the CK / I/O pin (pin 1) is automatically set to clock input. If an output register is not selected, pin 1~4 (like I4, I5) are set to dedicated data input. The register operates when the clock pulse goes positive. Clock division (program data) is determined according to the number of clocks and register selection.

(3) Initial state of registers at power-up

The user can program reset or preset of register outputs at power-up. Setting program data to 1 presets register output ; setting to 0 resets register output. This function can only be used when registers are selected.

(4) Clock Select

16 macro cells with built-in output registers use a 2-bit memory cell (clock select cell) to offer three patterns of clock operation : pattern where all 16 registers are synchronized with one clock, pattern where registers are divided into two and they are in sync with two clocks, and pattern where registers are divided into four and they are in sync with four clocks.

Macro cell

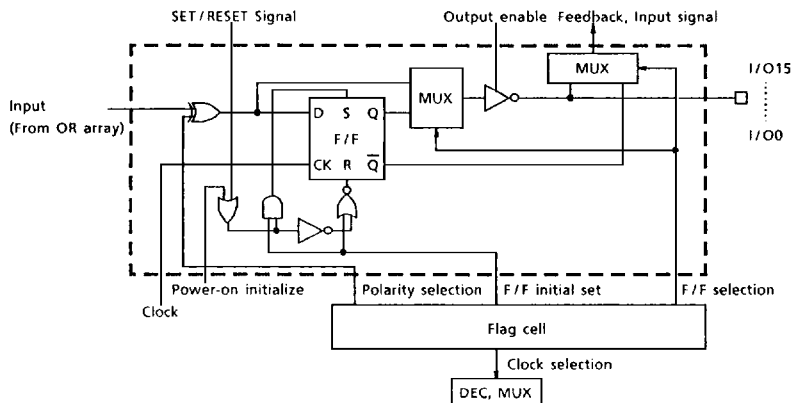

Clock division operating modes

Mode	Program data	Internal clock			
		CKA	CKB	CKC	CKD
0	(0, 0)	—	—	—	—
1	(0, 1)	CK0	CK0	CK0	CK0
2	(1, 0)	CK0	CK0	CK1	CK1
3	(1, 1)	CK0	CK1	CK2	CK3

There are four clock division operating modes. Modes are selected using the clock select cell program data. The program data are determined according to the number of clocks and register selection.

(1) Mode 0

Clocks input to the CK0/I0 to CK3/I3 pins are input to AND array ; not to flip/flop.

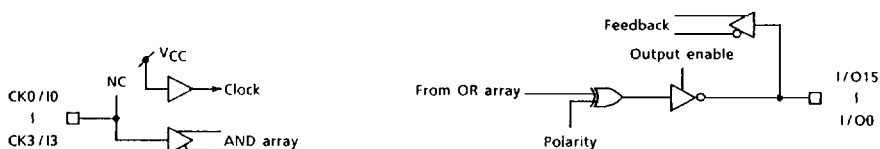

(2) Mode 1 (16-bit sync mode)

Clock input to the CK0/I0 pin is input to internal clocks, CKA, CKB, CKC, and CKD. Then the clocks are input to flip/flop of macro cells (1) to (4), resulting in maximum of 16-bit sync operation. At this time, input to pins CK1/I1 to CK3/I3 which are not used as clocks are input to the AND array.

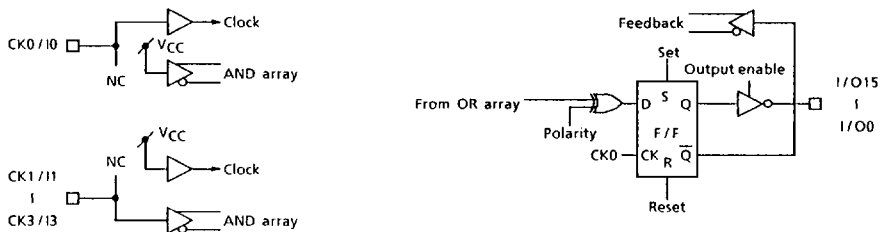

(3) Mode 2 (8-bit sync mode)

Clocks are input to the CK0/I0 and CK1/I1 pins. Clock input to the CK0/I0 pin is input to internal clocks, CKA and CKB, then input to the flip/flops of macro cells (3) and (4). Clock input to the CK1/I1 pin is input to internal clocks, CKC and CKD, then input to the flip/flops of macro cells (1) and (2). Up to 8-bit sync operation is performed at each clock. At this time, input to the CK2/I2 to CK3/I3 pins which are not used as clocks is input to the AND array.

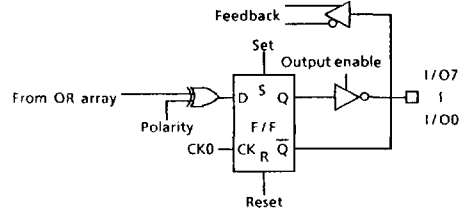
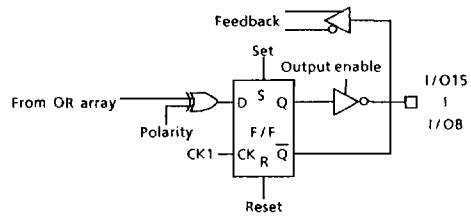
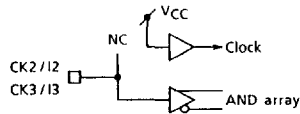
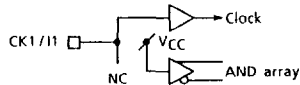
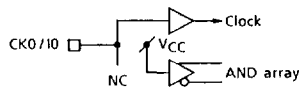

(4) Mode 3 (4-bit sync mode)

The CK0/I0, CK1/I1, CK2/I2, and CK3/I3 pins are used for clock input. Clock input to the CKA is input to the flip/flop of macro cell (4). Clock input to the CKB is input to the flip/flop of macro cell (3). Clock input to the CKC is input to the flip/flop of macro cell (2). Clock input to the CKD is input to the flip/flop of macro cell (1). Up to 4-bit sync operation is performed at each clock.

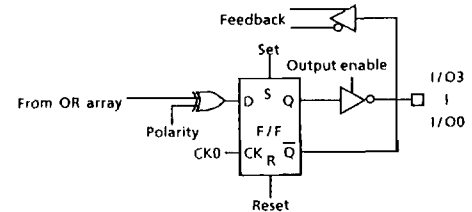
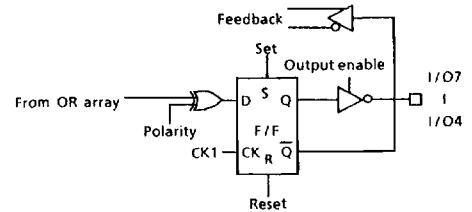
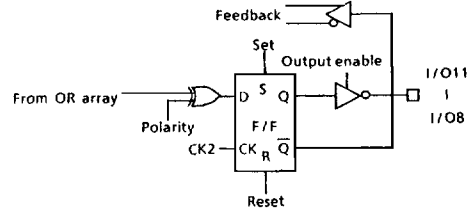
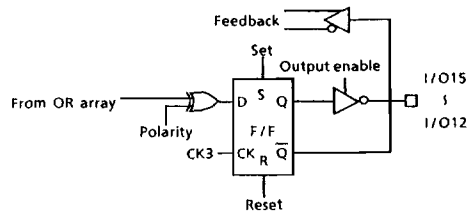
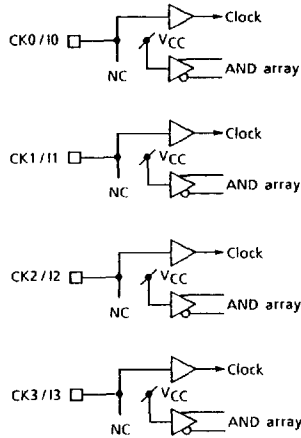

ABSOLUTE MAXIMUM RATINGS

PARAMETER	SYMBOL	VALUE	UNIT
Supply Voltage Range	V _{CC}	-0.5~7	V
DC Input Voltage	V _{IN}	-0.5~V _{CC} +0.5	V
DC Output Voltage	V _{OUT}	-0.5~V _{CC} +0.5	V
Input Diode Current	I _{IK}	±20	mA
Output Diode Current	I _{OK}	±20	mA
DC Output Current	I _{OUT}	±35	mA
DC V _{CC} /Ground Current	I _{CC}	±70	mA
Power Dissipation	P _D	500 (DIP) *	mW
Storage Temperature	T _{stg}	-65~150	°C
Lead Temperature (10s)	T _L	300	°C

* 500mW in the range of T_a = -40~65°C. From T_a = 65°C to 85°C a derating factor of -10mW/°C should be applied up to 300mW.

RECOMMENDED OPERATING CONDITIONS

PARAMETER	SYMBOL	VALUE	UNIT
Supply Voltage	V _{CC}	2~5.25	V
Input Voltage	V _{IN}	0~V _{CC}	V
Output Voltage	V _{OUT}	0~V _{CC}	V
Operating Temperature	T _{opr}	-40~85	°C
Input Rise and Fall Time	t _r , t _f	0~1000 (V _{CC} = 2.0V) 0~ 500 (V _{CC} = 5.0V ± 0.25V)	ns

DC ELECTRICAL CHARACTERISTICS

PARAMETER	SYM-BOL	TEST CIR-CUIT	TEST CONDITION		Ta = 25°C			Ta = -40 ~85°C		UNIT	
					V _{CC}	MIN.	TYP.	MAX.	MIN.		MAX.
High-level input voltage	V _{IH}	—			2.0	1.5	—	—	1.5	—	V
					3.0	2.10	—	—	2.10	—	
					5.25	3.67	—	—	3.67	—	
Low-level input voltage	V _{IL}	—			2.0	—	—	0.5	—	0.5	V
					3.0	—	—	0.9	—	0.9	
					5.25	—	—	1.57	—	1.57	
High-level output voltage	V _{OH}	—	V _{IN} = V _{IH} or V _{IL}	I _{OH} = -20μA	2.0	1.9	2.0	—	1.9	—	V
				I _{OH} = -4mA	3.0	2.9	3.0	—	2.9	—	
Low-level output voltage	V _{OL}	—	V _{IN} = V _{IH} or V _{IL}	I _{OL} = 20μA	5.25	5.15	5.25	—	5.15	—	V
				I _{OL} = 4mA	4.75	4.43	4.56	—	4.38	—	
				I _{OL} = 20μA	2.0	—	0.0	0.1	—	—	
3-State output off-state current	I _{OZ}	—	V _{IN} = V _{IH} or V _{IL} V _{OUT} = V _{CC} or GND	I _{OL} = 20μA	3.0	—	0.0	0.1	—	—	μA
				I _{OL} = 4mA	5.25	—	0.0	0.1	—	—	
				I _{OL} = 20μA	4.75	—	0.18	0.26	—	0.33	
Input leakage current	I _{IN}	—	V _{IN} = V _{CC} or GND	5.25	—	—	±0.1	—	±1.0	μA	
Quiescent current	I _{CCSB}	—	V _{IN} = V _{CC} or GND Standby	5.25	—	—	4.0	—	40.0	μA	
Operating current	I _{CCOP}	—	f _{IN} = 1MHz Operating	5.25	—	—	—	—	40.0	mA	

TC9804P

AC ELECTRICAL CHARACTERISTICS ($C_L = 25\text{pF}$, Input $t_r = t_f = 3\text{ns}$)

PARAMETER	SYM-BOL	TEST CIR-CUIT	TEST CONDITION	Ta = 25°C			Ta = -40 ~ 85°C		UNIT	
				VCC	MIN.	TYP.	MAX.	MIN.		MAX.
Propagation Delay Time (Input, I/O-Output)	t _{PLH} t _{PHL}	—		2.0	—	120	200	—	220	ns
				3.0	—	—	—	—	—	
				5 ± 0.25	—	33	50	—	55	
Propagation Delay Time (Clock-Output)	t _{COR} t _{COF}	—		2.0	—	30	55	—	60	ns
				3.0	—	—	—	—	—	
				5 ± 0.25	—	8	12	—	14	
Output Enable Time	t _{PZL} t _{PZH}	—		2.0	—	120	190	—	210	ns
				3.0	—	—	—	—	—	
				5 ± 0.25	—	26	40	—	44	
Output Disable Time	t _{PLZ} t _{PHZ}	—		2.0	—	50	70	—	90	ns
				3.0	—	—	—	—	—	
				5 ± 0.25	—	21	32	—	37	
Minimum Pulse Width	t _{W(L)} t _{W(H)}	—		2.0	—	8	15	—	19	ns
				3.0	—	—	—	—	—	
				5 ± 0.25	—	3	6	—	8	
Minimum Set-up Time	t _S	—		2.0	—	—	200	—	220	ns
				3.0	—	—	—	—	—	
				5 ± 0.25	—	—	42	—	47	
Minimum Hold Time	t _H	—		2.0	—	—	0	—	0	ns
				3.0	—	—	0	—	0	
				5 ± 0.25	—	—	0	—	0	
Minimum Removal Time	t _{rem}	—		2.0	—	100	170	—	190	ns
				3.0	—	—	—	—	—	
				5 ± 0.25	—	19	29	—	33	
Maximum Clock Frequency	f _{MAX}	—		2.0	2.0	—	—	1.6	—	MHz
				3.0	—	—	—	—	—	
				5 ± 0.25	14	—	—	12	—	

Switching Characteristic Test Waveform

1) t_{PD} (t_{PLH} , t_{PHL})

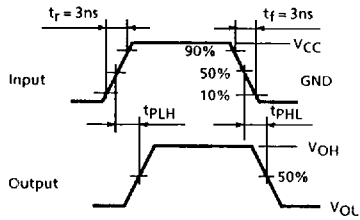

2) t_{CO} (t_{COR} , t_{COF} , t_s , t_h , t_w)

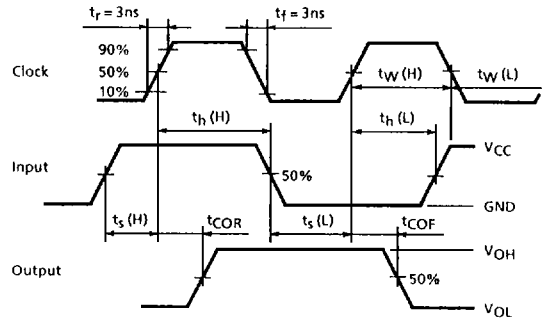

3) t_{rem}

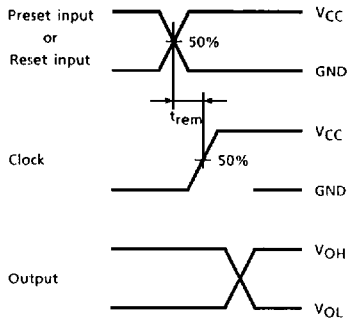

4) t_{PLZ} , t_{PHZ} , t_{PZL} , t_{PZH}

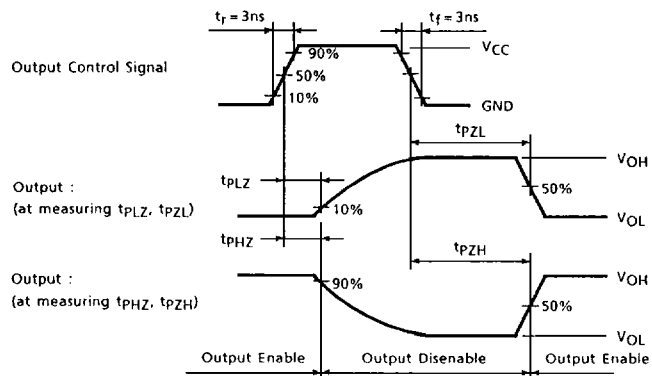

5) Output Test Connection Diagram

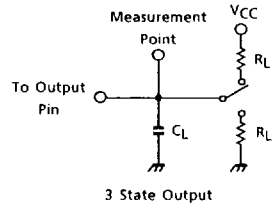
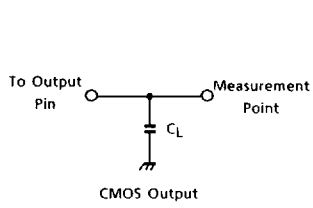

Note) C_L includes the capacitance of probe.