



Home Appliances

SYSTEM SOLUTION GUIDE

HOME APPLIANCES

Panasonic proposes semicon Home Appliances



ductor solutions for the latest

Contents

1 Contents	1
2 32-bit Microcomputer for High-accuracy Inverter Control	3
3 Intelligent Power Device (IPD)	3
4 DC-DC Converter ICs	4
5 MOS FETs for DC-DC Converters	4
6 Safety Monitor LSIs	5
7 Motor Control/System Control Microcomputer	5
8 Display Control Microcomputer	6
9 Non-contact Power Supply ICs	6
10 HMI Display LSI	7
11 Power Line Communications LSIs	7
12 LED Driver LSIs	8
13 Voice Guidance Microcomputer	8
14 Photo IC	9
15 Luminance Sensor	9
16 Surface-mount Chip LEDs	10
17 Small Signal Transistor Series	10
18 Diode Series	11

2. 32-bit Microcomputer for High-accuracy Inverter Control

Overview

MN103SFG5K/K0K/K1K/J9D/N5D/N6G is a 32-bit microcomputer that incorporates Panasonic's original 32-bit CPU "AM32" and features small code size, high-performance and low power consumption operation. By incorporating 3-phase PWM for motor control, high-speed A/D converter and expanded arithmetic unit (fast multiplication and division, high-speed arithmetic unit for inverter control), MN103SFG5K/K0K/K1K/J9D/N5D/N6G enables high-efficiency and high-precision inverter control by low power consumption. MN103SFN5D/N6G have internal op-amps, reducing peripheral components. Also, it features various peripheral functions such as a high-precision internal oscillator and a clock monitor function. These functions realize to comply safety standards (IEC60730 and others).

Product Information

Part No.	Maximum Operating Frequency	ROM (Bytes)	RAM (Bytes)	External Interrupt (Number)	Multi-functional Timer			3-phase PWM for Motor Control (Number)	A/D Converter (ch)	Serial Interface		I/O Port Count (ports)	Package
					8-bit Timers (Number)	16-bit Timers (Number)	WDT (Number)			Combined Synchronous Type/UART (full duplex)	Combined Synchronous Type/Multimaster I ² C		
MN103SFG5K	60 MHz	256K	12K	16	16	9	1	3	(10-bit) 3 units Total 28	3	1	I/O pin: 112	LQFP128-P-1818C
MN103SFK0K			8K		12	12		7	2			(10-bit) 3 units Total 20	I/O pin: 84
MN103SFK1K				8K		12		7	2			(10-bit) 3 units Total 16	I/O pin: 64
MN103SFJ9D		64K	4K	8	8	3	1	(12-bit) 1 unit (10-bit) 1 unit Total 8-ch	2	0	I/O pin: 30	QFP044-P-1010F	
MN103SFN5D		8K	10	10	12		2	(10-bit) 2 units Total 12	3		I/O pin: 46	LQFP064-P-1414 TQFP064-P-1010C	
MN103SFN6G			128K	12	12	5	2	(10-bit) 2 units Total 16	3		I/O pin: 62	LFP080-P-1414A	

Applications

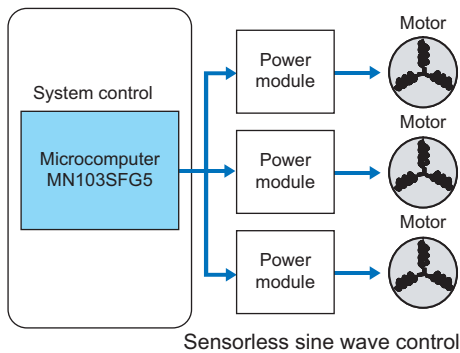

Image Sample



Points on Appeal (Features)

- Reduces the processing time to 60% than before by built-in arithmetic unit for inverter control (3-phase to 2-phase conversion, 2-phase to 3-phase conversion, PI control, LPF, etc.) (MN103SFG5K/K0K/K1K only)
- Power consumption is reduced by 30%, compared to our previous product.
- Possible to comply to the safety standards for home appliances without external parts.
- The combination of 3-phase PWM for motor control, high-speed A/D converter and external functions such as a timer enables to comply any type of inverter controls.
- Lineup development for different numbers of 3-phase motors to handle various kinds of systems.

3. Intelligent Power Device (IPD)

Overview

By using PWM control as the peak current control method when at rated load and intermittent oscillation control when at light load, IPDs provide high efficiency from light loads to heavy loads as well as contributing to reduce the standby energy consumption of microcomputer power supply.

Product Information ⇒ For details, please refer to this web page: <http://www.semicon.panasonic.co.jp/e-ipd>

Typical example	Series Example	Part No.	Overheating Protection	Overload Protection	Overvoltage Protection	Package
Standby energy-conserving 3-terminal	MIP2L* series		Self-recovering	Timer intermittent	None	TO-220-A2 DIP7-A1
For compact power supply	MIP2K* series		Latch	Foldback	Latch	DIP7-A1
For new chopper power supplies	MIP35* series		Self-recovering	Timer intermittent	Latch	DIP7-A1

Applications

1. Isolated flyback system

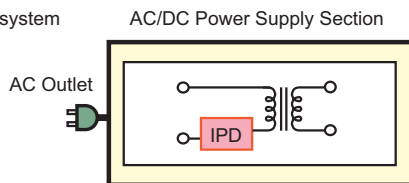

2. Non-isolated chopper system

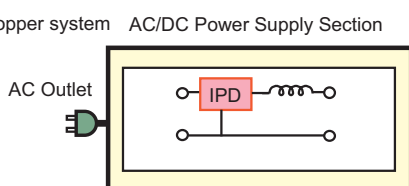

Image Sample



Points on Appeal (Features)

- Frequency jitter function reduces average noise.
- MIP2L* series are 3-terminal packages to enable simple circuit construction and achieve no-load power consumption of less than 0.1 W for power supplies with worldwide input and output of 60 W or less.
- MIP2K* series achieve no-load power consumption of 50 mW for power supplies with worldwide input and output of 15 W or less, as well as having a built-in ILIMIT input compensation circuit to reduce maximum output voltage dependence on input voltage.
- MIP35* series achieves high functionality and low noise for non-isolated chopper systems. They are also compatible with feedback-photocoupler-less systems.

Caution Point

Please refer to "Precautions on the Sales of IPDs" provided in this catalog.

4. DC-DC Converter ICs

Overview

This product series can be used to boost power supply efficiency in the high-current range of up to 10 A, lowering the power consumption of host devices. It also facilitates more compact designs by implementing a high-performance power supply in a small footprint.

Product Information

	High current, medium breakdown voltage DC-DC series			High current, low breakdown voltage DC-DC series		
	NN30310A	NN30311A	NN30312A	NN30194A	NN30195A	NN30196A
Input voltage	4.5 V to 30 V			4.5 V to 5.6 V		
Absolute maximum rating	33 V			6 V		
Output voltage	0.75 V to 5.5 V			0.6 V to 3.5 V		
Output current	3 A	6 A	10 A	3 A	6 A	9 A
Step-down DC-DC	1ch			1ch		
Power transistors	2 built-in low-on-resistance trench MOS FETs					
On-resistance	High-side	25 mΩ	25 mΩ	9 mΩ	25 mΩ	25 mΩ
	Low-side	25 mΩ	9 mΩ	9 mΩ	25 mΩ	9 mΩ
Control method	Step-down hysteretic control			Step-down hysteretic control		
Oscillation frequency	0.25 M/0.75 M/1.25 MHz			0.5 M/1 M/2 MHz		
Rectification method	Synchronous rectification					
Protective functionality	Undervoltage, overheat, overvoltage, over-current, short					
Package	HQFN24-A3-0404	HQFN40-A3-0606		HQFN24-A3-0404		HQFN40-A3-0606

Applications

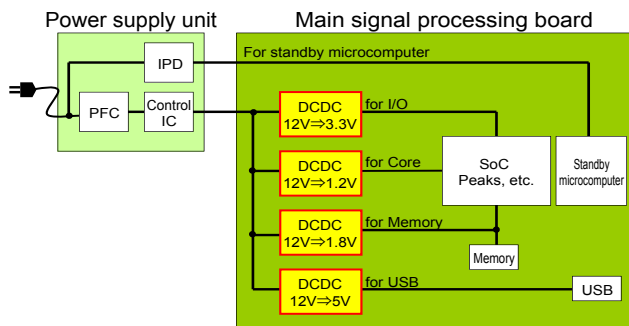

Image Sample



Points on Appeal (Features)

- Built-in low-on-resistance trench MOS FETs provide high efficiency, reducing host device power consumption and heat dissipation.
- This product series can be used to implement a high-speed-response DC-DC converter. The large safety margin provided for the operating supply voltage range helps ensure that the host device operates in a stable manner.
- Having fewer mounted components contributes to space-saving set designs, helping to reduce the size of host devices.

5. MOS FETs for DC-DC Converters

Overview

An advanced fine process delivers some of the industry's lowest $R_{DS(on)}$ and Q_g values. These energy-saving devices can boost device efficiency.

Product Information

Polarity	Part No.	V_{DSS} (V)	V_{GSS} (V)	I_D (A)	$R_{DS(on)}$ (mΩ) typ.		Q_g (nc)	C_{iss} (pF)	Package
					$V_{GS} = 4.5$ V	$V_{GS} = 10$ V			
Nch Single	SK860301	33	±20	44	2.5	2	22.5	3500	HSO8-F1-B
	SK860302			38	3.1	2.5	19	3000	
	SK850305			18	10	7	7	950	HSO8-F2-B
	SK850306			15	13	9	6	730	
	SK840303			22	7	5	10	1450	HSSO8-F1-B
	SK830305			16	10	7	7	950	HSSO8-F2-B
	SK830306			14	13	9	6	730	
	FK8V0303			12	8	5	10.2	1100	WMini8-F1
	FK8V0304			10	11	7	7.2	750	
	FK8V0305			8	16	11	5.1	520	
FK8V0306	6.5	22	15	3.8	360				
Nch Dual	FC8V3303			6.5	22	15	3.8	360	
Dual	FC8J3304			5.0	48	32	2.8	220	

Applications

- Step-up circuit

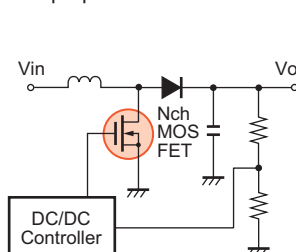

- Step-down circuit/
synchronous rectification

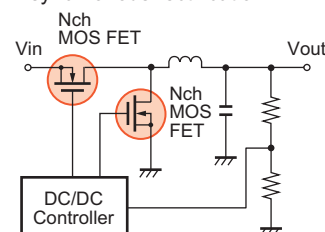
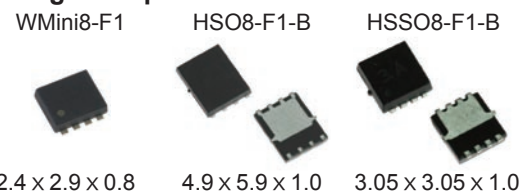

Image Sample



Points on Appeal (Features)

- Low $R_{DS(on)}$ and Q_g values
- Package with integrated heat sink on bottom (HSO8, HSSO8)

6. Safety Monitor LSIs

Overview

AN49239A monitors the current of 3-wire of 3-phase AC power applied to 3-phase motor respectively, using external detection resistors. Then AN49239A amplifies the current, and outputs analog.

Moreover, when the current more than setup value is applied, the detection signal which shows an oversupply is output.

Product Information

Part No.	Over-voltage Detection	Over-current Detection	Temperature Detection	Analog Output	Package
AN49231A	1-ch	1-ch	5-ch	○	XBGA035-W-2424
AN49232A	2-ch	2-ch	6-ch	○	XBGA035-W-2727AEA
AN49236A	—	1-ch	—	○	UBGA009-W-1717AEA
AN49239A	—	3-ch	—	○	SSOP024-P0300E

Applications

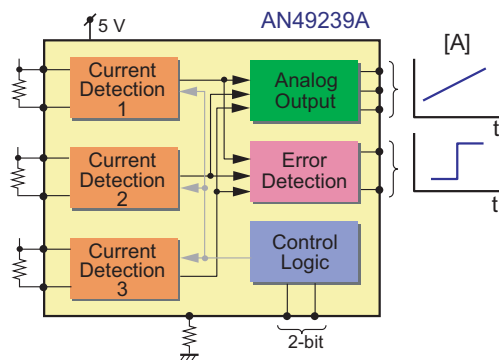

Image Sample



Points on Appeal (Features)

- High-accuracy current detection function (3 systems)
- Detection-value setting using external resistor (Common for all 3 systems)
- Detection signal output (Common for all 3 systems)
- Individual analog output for detection value from 3 systems
- Variable amplification ratio for analog output (4 levels)

7. Motor Control/System Control Microcomputer

Overview

MN101EF51A/52A/A0A/A1A and MN103LF08K are general-purpose flash microcomputers featuring the 8-bit CPU "AM13E" and 32-bit CPU "AM32L," respectively. They incorporate built-in 3-phase and 4-phase PWM functionality for motor control, providing an easy way to implement various motor control configurations, including for stepping motors, brushless motors, and ultrasonic motors.

Product Information

Part No.	Internal ROM Type	ROM (Bytes)	RAM (Bytes)	Minimum Command Execution Time/Operating Voltage ($\mu\text{s/V}$)	I/O Port Count (ports) [Single-chip mode]	Interrupts (Factors)	8-bit Timers (Number)	16-bit Timers (Number)	Serial Interface			A/D Converter (ch)	Package
									Combined Synchronous Type/UART	Combined Synchronous Type/IC	Combined Synchronous Type/UART/LIN		
MN101EF51A	F	32K	1K	0.05 / 2.7 to 5.5 0.125 / 1.8 to 5.5	36	25	5	2	1	1	1	12	QFP044-P-1010F TQFP048-P-0707B
MN101EF52A													
MN101EFA1A				2	1	0			12	QFP044-P-1010F TQFP048-P-0707B			
MN101EFA0A											1	8	TQFP032-P-0707A
MN103LF08K				256K	20K	0.025 / 2.2 to 5.5			81	81	7	8	5

Applications

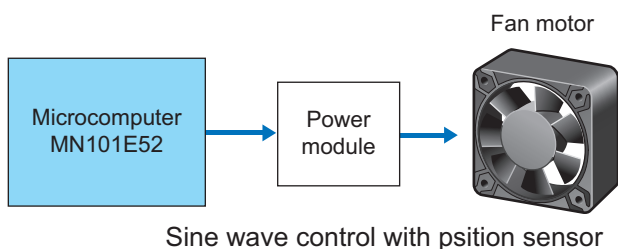
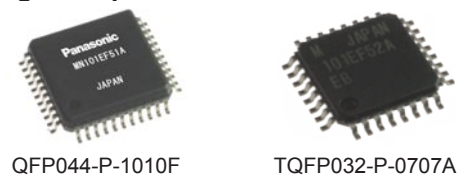

Image Sample



Points on Appeal (Features)

- Low-voltage operation: 5.5 V to 1.8 V (MN101EF51A/52A only)
- The combination of 3-phase PWM inverter control
- Strengthened multiplication/division: 16-bit \times 16-bit, 32-bit \div 16-bit
- High-accuracy internal oscillator ($\pm 1.6\%$, normal temperature $\pm 1.0\%$) (MN101EF51A/52A only)

8. Display Control Microcomputer

Overview

MN101EF50D/57G/76K is an 8-bit flash microcomputer that incorporates the 8-bit CPU "AM13E" and offers small code sizes, low power consumption, and high-speed operation. They also have an internal LCD driver capable of handling displays of up to 220 pixels. Plus, they are also equipped with high-accuracy internal oscillators and high-accuracy supply voltage detection circuits to enable reducing the external component count to achieve reduced system cost and simplifying equipment design. The product also incorporates built-in 3-phase and 4-phase PWM functionality for motor control, providing an easy way to implement various motor control configurations, including for stepping motors, brushless motors, and ultrasonic motors.

Product Information

Part No.	Internal ROM Type	ROM (Bytes)	RAM (Bytes)	Minimum Command Execution Time/ Operating Voltage ($\mu\text{s}/\text{V}$)	I/O Port Count (ports) [Single-chip mode]	Interrupts (Factors)	8-bit Timers (Number)	16-bit Timers (Number)	Serial Interface			A/D Converter (ch)	D/A Converter (ch)	LCD	High-accuracy Internal Oscillator Function	Package
									Combined Synchronous Type/UART	Combined Synchronous Type/PC	Synchronous Type					
MN101EF50D	F	64K	4K	0.05 / 2.7 to 5.5 0.125 / 1.8 to 5.5	55	30	7	2	3	1	0	12	—	SEG28 COM8	High-accuracy internal oscillator 1.6%	LQFP064-P-1414A
MN101EF57G	F	128K	6K	0.05 / 2.7 to 5.5 0.125 / 1.8 to 5.5	70	34	7	3	3	1	0	16	2	SEG41 COM4	High-accuracy internal oscillator 1.6%	LQFP080-P-1414A TQFP080-P-1212D
MN101EF76K	F	256K	10K	0.05 / 2.7 to 5.5 0.125 / 1.8 to 5.5	104	36	7	3	4	1	0	24	4	SEG55 COM4	High-accuracy internal oscillator 1.6%	LQFP128-P-1818C

Applications



Display panel

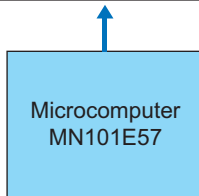
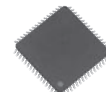

Image Sample



LQFP080-P-1414A



LQFP064-P-1414A

Points on Appeal (Features)

- Ultra-wide supply voltage range: 5.5 V to 1.8 V
- Equipped with high-accuracy internal oscillator (16 MHz/20 MHz $\pm 1.6\%$).
- Equipped with high-accuracy supply voltage detection (selectable from 10 potentials; accuracy: ± 0.1 V).
- Equipped with PWM function (4-phase; complementary 3-phase) to control various motors.
- Built-in LCD driver

9. Non-contact Power Supply ICs

Overview

AN32250A, AN32255A and AN32256A control power transmission during non-contact power supply.

AN32250A controls the primary side sending the power and AN32255A controls the secondary side receiving the power to control the power being supplied to the equipment from the secondary side.

AN32256A controls the Qi standard-compliant secondary side receiving the power to control the power being supplied.

Product Information

Part No.	Application	Operating Voltage	Function	Package
▲AN32250A	Non-contact power supply devices	Input: 5 V	Transmission circuit (power-transmitting side), over-current/over-voltage protection, temperature detection, LED driver, ID verification/foreign-material detection, I ² C serial interface	QFN044-P-0606D
▲AN32255A		Output: 5 V *1 (2 A)	Transmission circuit (power-receiving side), DC/DC converter, over-current protection, temperature detection, LED driver, ID verification/foreign-material detection, I ² C serial interface	XBGA035-W-2626AEL
▲AN32256A		Output: 5 V (1 A)	Qi standard-compliant transmission circuit (power-receiving side), temperature detection, LED driver, ID verification, I ² C serial interface, LDO, overheat/over-current protection	MBGA020-W-2127AEL

* 1: Can generate 22 W of output with additional external parts. ▲: Under development

Applications

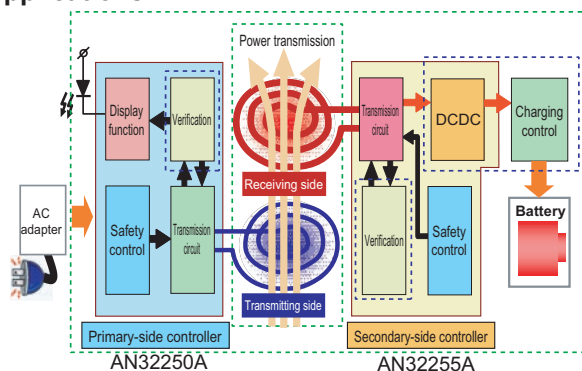

Image Sample



AN32250A QFN044-P-0606D

Points on Appeal (Features)

- Built-in foreign-material detection circuit
- Built-in verification function
- I²C serial interface
- Built-in overheating detection circuit and over-voltage detection circuit
- Built-in DC/DC converter (AN32255A)
- WPC Ver. 1.0 compatible (AN32256A)

10. HMI Display LSI

■ Overview

Thanks to extensive graphics functionality and a full range of video input interfaces, these LSIs can be used to augment information terminal display functionality with an upscale appearance that blends in with the room interior while improving the expandability of displayed information.

■ Product Information

Part No.	TypeA	TypeB	TypeC
Composite/analog RGB/ component/S-video		○	
Digital video input		○	
Digital video output	○ Up to WVGA screen		○ Up to 2 WVGA screens
Graphics	◎		
Package	TQFP128-P-1414C (128 Pins/14 mm □ QFP)	LQFP176-P-2020A (176 Pins/20 mm □ QFP)	LQFP216-P-2424B (216 Pins/24 mm □ QFP)

■ Applications

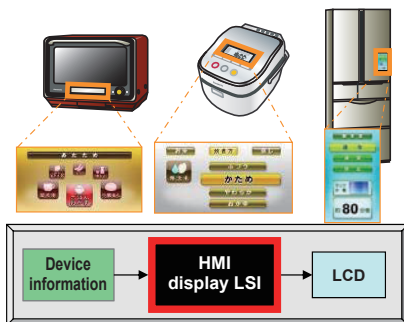

■ Image Sample



LQFP176-P-2020A

■ Points on Appeal (Features)

- Two-dimensional graphics display capability augments information terminals with an upscale appearance.
- Supports composite analog input and state-of-the-art digital video input, allowing systems to be expanded and product lineups developed.
- Reduces the load on the host CPU (thanks to a built-in scenario execution microcomputer).

11. Power Line Communications LSIs

■ Overview

These products offer new connectivity solutions by applying Panasonic's strengths in HD-PLC technology to residential and industrial equipment applications. By allowing all equipment wiring to be replaced by power lines, they can be used to dramatically reduce the number of connectors and harnesses needed in the target application.

■ Product Information

Part No.	Application	Estimated Transmission Range *1	Effective Data Transfer Rate *2	Package
MN1A94100	Communications adapters	200 m	80 Mbps	TQFP128-P-1414C
MN101EF69D		5 m	45 kbps	TQFN044-P-0606B

*1: Varies with transmission line. *2: Total for all units.

When used to send and receive data over power lines with a carrier frequency of 2 MHz to 30 MHz or from 10 kHz to 450 kHz/2 MHz to 30 MHz in Japan, this device constitutes a general digital transmission device (high-frequency equipment) as defined by the Radio Act. Please note that a type approval is required when using this product to communicate over public power lines.

■ Applications

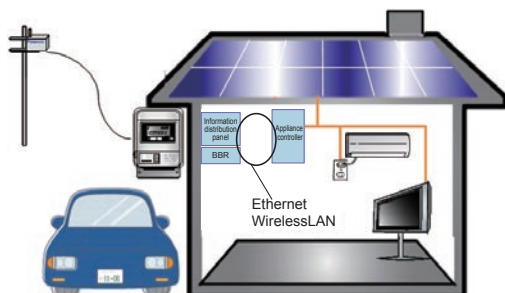

■ Image Sample



TQFP128-P-1414C

■ Points on Appeal (Features)

- This wired communications method uses power lines as its media, eliminating the need to augment power lines with new wiring.
- It provides an easy way to add communications capability to existing systems, reducing the number of wires needed.
 - Data can be sent and received between any two units.

12. LED Driver LSIs

Overview

LED driver with built-in functions for dot-matrix, photoflash, RGB color unit, LCD backlight, etc. It is equipped with various registers to enable animation movie patterns and brightness adjustment. It contributes to achieving reduced size and cost for variegated illumination or information display using LEDs and differentiation by set design.

Product Information

Parts No.	Operating Voltage (V)	No. of Channels	PWM Steps	Current Steps	LDO	Control Method	Package
AN30259A	3.1 to 6.0	3	128	256	-	I ² C	XBGA012-W-1316
AN32180A	3.1 to 5.5	4 x 4	256	16	1ch	I ² C	QFN016-P-0304C
AN32183A	3.1 to 5.5	9 x 9	256	16	1ch	I ² C	SSOP024-P-0300F

Applications

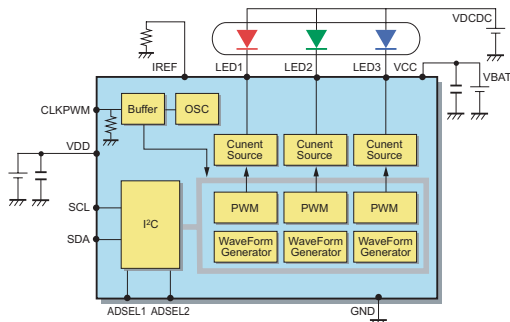

Image Sample



SSOP024-P-0300F

Points on Appeal (Features)

- 200 pre-installed patterns in built-in ROM. Enables reducing CPU load.
- Brightness adjustment: Enables fine setting of luminance in a maximum of 256 steps.
- PWM slope control: Enables smooth display in a maximum of 128 steps
- Control method: Switchable between 3-line serial (SPI) and I²C.

13. Voice Guidance Microcomputer

Overview

The MN101E30/59 series of 8-bit microcomputers incorporates the 8-bit CPU "AM13E" and offers small code sizes, low power consumption, and high-speed operation. Built-in high-accuracy D/A converters and LPF enable high-quality voice guidance to be achieved. In addition, abundant peripheral functions such as LCD driver, multi-function timers, serial interface, etc., providing system control and voice guidance in a single microcomputer.

Product Information

Part No.	Internal ROM Type	ROM (Bytes)	RAM (Bytes)	Minimum Command Execution Time/Operating Voltage (µs/V)	I/O Port Count (ports) [Single-chip mode]	Interrupts (Factors)	8-bit Timers (Number)	16-bit Timers (Number)	19-bit Timers (Number)	Serial Interface				A/D Converter (ch)	D/A Converter (ch)	Display Control Function	Package	
										Combined Synchronous Type/UART	Combined Synchronous Type/I ² C	Synchronous Type	UART					
MN101E30N	M	508K	8K	0.05 / 2.2 to 5.5	85	30	7	3	0	4	1	0	0	1	12	5	SEG55 COM4	QFP100-P-1818B
MN101E30R		928K																
MN101EF30R	F	928K	8K	0.05 / 2.2 to 5.5	85	30	7	3	0	4	1	0	0	1	12	5	SEG55 COM4	QFP100-P-1818B
MN101E59R	M	928K	8K	0.05 / 2.2 to 5.5	85	30	7	3	0	4	1	0	0	1	12	5	SEG55 COM4	QFP100-P-1818B
MN101EF59R	F	928K	8K	0.05 / 2.2 to 5.5	85	30	7	3	0	4	1	0	0	1	12	5	SEG55 COM4	QFP100-P-1818B

Applications

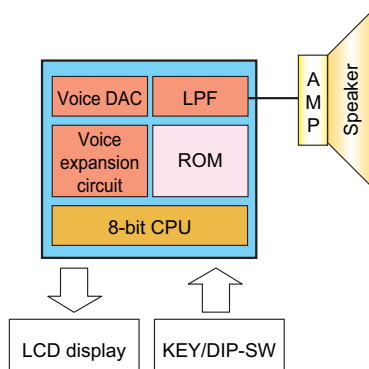

Image Sample



QFP100-P-1818B

Points on Appeal (Features)

- Built-in high-accuracy 20-bit D/A converter, LPF, voice expansion circuit
- Built-in large-capacity ROM enables long-time playback
- Abundant built-in peripheral functions such as LCD driver, etc.
- Maintains specification and pin-layout interchangeability with general-purpose MN101E29 series microcomputers, enabling selection according to system specifications.

14. Photo IC

Overview

PNJ4805M series is a low-current-consumption type infrared remote control receptor photo IC. Multi-voltage compatible ($V_{CC} = 2.7\text{ V}$ to 5.5 V), so current consumption is reduced compared to previous products.

Can be used for a wide range of remote-control applications, such as digital equipment like TVs, DVD equipment, etc., home appliances such as air conditioners, etc., and game equipment or electronic toys, etc.

Product Information

($T_a = 25^\circ\text{C}$, $V_{CC} = 3.3\text{ V}$)

Part No.	Application	Operating Supply Voltage V_{CC} (V)			Supply Current I_{CC} (mA)			Maximum Reception Distance L (m)	Center Frequency f_o (kHz)	Package
		Min.	Typ.	Max.	Min.	Typ.	Max.	Min.		
PNJ4805M Series	For IR remote control	2.7	3.3	5.5	—	0.3	0.4	9	32.7, 36.7, 38, 40, 56.9	Miniature lead type

Applications

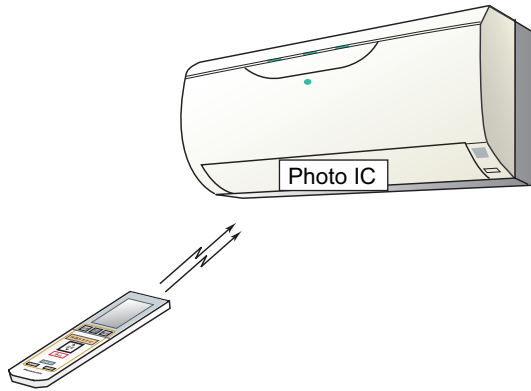

Image Sample



PNJ4805M Series

Points on Appeal (Features)

- Low current consumption: $I_{CC} = 0.3\text{ mA}$ (typ)
- Compact general-purpose package (lead type)
6.5 × 4.7 × 4.0 mm
- Abundant BPF central frequency lineup:
32.7, 36.7, 38.0, 40.0, 56.9 kHz
- Compatible with lead forming shape
- Metal holder compatible for improved EMF noise characteristics
- Pb-free (conforms to RoHS directive)

15. Luminance Sensor

Overview

Photo IC with built-in photodiode and current amplifier circuit.

Senses ambient brightness and controls the screen brightness to maintain the screen's ease of viewing.

Has wavelength characteristics similar to the visual sensitivity of the human eye to enable control close to human senses.

Product Information

Part No.	I_{CC} typ. (μA)	I_o ($V_{CC} = 3.0\text{ V}$)		λ_p (nm)	Package
		L = 0 lx (μA)	L = 100 lx (μA)		
PNJ4K01F	480	4.3	43	560	KPTFTN6K0001
PNJ4K11F					KPTFTN4K0002

Applications

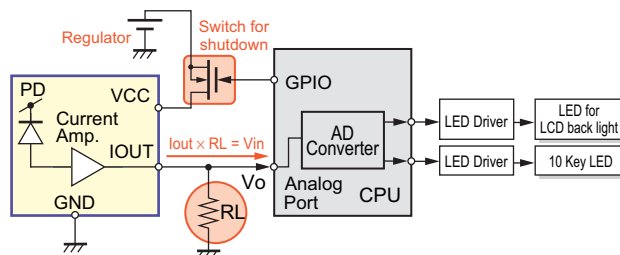

Image Sample



PNJ4K01F



PNJ4K11F

Points on Appeal (Features)

- Small package: 1.5 × 1.55 × 0.55 mm (PNJ4K01F)
- Wavelength characteristics similar to the visual sensitivity of the human eye
- Good linearity of output current in response to incident luminosity
PNJ4K01F: Linear output
PNJ4K11F: For back-side mounting

16. Surface-mount Chip LEDs

■ Overview

Ideal for various indicators and pilot lamp illumination with abundant color variations.
Thin miniature package enables use in a variety of applications.

■ Product Information

Part No.	Color	V _F (V)	I _o (mcd)	λ _d (nm)	λ _p (nm)	Δλ	Condition	I _R (μA)	Condition
		Typ.	Typ.	Typ.	Typ.	Typ.		Max.	
LNJ326W83RA1	Yellow Green	2.05	18.0	572	575	15	I _F = 10 mA	100	V _R = 4 V
LNJ426W83RA1	Amber	2.05	35.0	589	595	15	I _F = 10 mA	100	V _R = 4 V
LNJ626W8CRA	Pure Green	2.90	40.0	527	520	30	I _F = 5 mA	100	V _R = 5 V
LNJ826W83RA	Orange	1.90	19.0	620	630	13	I _F = 5 mA	100	V _R = 4 V
LNJ826W86RA	Soft Orange	1.92	16.9	605	610	15	I _F = 10 mA	100	V _R = 4 V
LNJ926W8CRA	Blue	2.90	11.5	470	465	20	I _F = 5 mA	100	V _R = 5 V
LNJ026X8BRA4	White	3.0	150.0	X: 0.26 to 0.32 Y: 0.21 to 0.38			I _F = 5 mA	100	V _R = 5 V

■ Applications

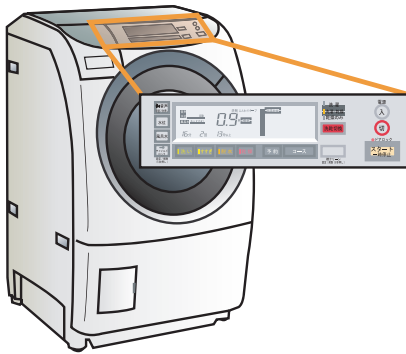

■ Image Sample

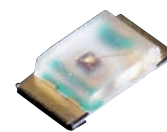

KLTFTN2K2600

■ Points on Appeal (Features)

- Ultra-thin LED: t = 0.35 mm
- Package size:
1.6(L) × 0.8(W) × 0.35(H) mm

17. Small Signal Transistor Series

■ Overview

This transistor series delivers a high level of reliability thanks to its use of an advanced fine process. Furthermore, use of compact packages helps reduce set size.

■ Product Information

Function	Part No.		V _{CEO} (V)	I _c (A)	V _{ce(sat)} max.		hFE	Package	SIZE L × W × H(mm)
	PNP	NPN			(V)	I _c (A)			
Single Tr	DSA2001	DSC2001	-50/50	-0.1/0.1	0.5/0.3	0.1	210 to 460	Mini3-G3-B	1.5 × 2.9 × 1.1
	DSA2002	DSC2002		-0.5/0.5	0.6	0.3	120 to 340	Mini3-G3-B-B	
	DSA2005	DSC2005		-0.2/0.2	0.3	0.1	150 to 390	Mini3-G3-B	
Compound Tr	DMA20***	DMC20***	Varies with combination				Mini5-G3-B Mini6-G4-B		
Built-in resistance	DRA21***	DRC21***	-50/50	-0.1/0.1	-	-	-	Mini3-G3-B	
Compound built-in resistance	DMA26***	DMC26***						Mini5-G3-B Mini6-G4-B	

■ Applications

- Switching circuit
- Power-supply circuit
- Others

■ Image Sample



Mini3-G3-B

Mini6-G4-B

■ Points on Appeal (Features)

- Improved reliability thanks to use of new process
- Various product lineup
- Compact surface-mount packages
- Use halogen-free resin in all part numbers

18. Diode Series

■ Overview

These diodes offer both compact size and high performance. They deliver a high level of reliability thanks to their use of an advanced fine process based on state-of-the-art technology. Furthermore, use of compact packages helps reduce set size.

■ Product Information

Function	Part No.	VR (V)	IF (A)	VF max.		IR max. (μA)	Package	SIZE
				(V)	IF(A)			L × W × H(mm)
Switching diode	DA2J101	80	0.1	-	-	0.1	SMini2-F5-B	1.25 × 1.7 × 0.7
	DA3X102D DA3X103E						Mini3-G3-B	1.5 × 2.9 × 1.1
Fast-recovery diode	DA22F21	200 *1	1.0	0.98	1.0	10 *2	Mini2-F3-B	1.6 × 2.6 × 0.8
Schottky barrier diode	DB2J209	20	0.5	0.5	0.5	30	SMini2-F5-B	1.25 × 1.7 × 0.7
	DB2J314	30	0.1	1.0	0.03	0.3		
	DB24602	60	3.0	0.6	3.0	150	TMiniP2-F2-B	2.4 × 3.8 × 0.85
Zener diode	DZ2J***	PT=0.2W	Vz = 2.4 V to 39 V				SMini2-F5-B	1.25 × 1.7 × 0.7
	DZ2W***	PT=1W	Vz = 2.4 V to 51 V				Mini2-F3-B	1.6 × 2.6 × 0.8
	DZ24***	PT=2W	Vz = 4.7 V to 51 V				TMiniP2-F2-B	2.4 × 3.8 × 0.85

*1: VRRM *2: IRRM

■ Applications

- Switching circuit
- Power supply secondary-side rectification circuit (fast-recovery diode)
- Constant-voltage circuit, surge protection circuit (Zener diode)
- Other

■ Image Sample



TMiniP2-F2-B



Mini2-F3-B



SMini2-F5-B

■ Points on Appeal (Features)

- Low-VF/low-IR characteristics
- Extensive product lineup
- Compact surface-mount packages
- All products use halogen-free resin.

Precautions on the Sales of IPDs

- 1) The sale and/or the export of IPD products to customers located in certain countries is restricted by the Agreement made and executed by and between Power Integrations, Inc. and Panasonic Corporation. For details, refer to the following Attached table "IPD availability by customer."
- 2) IPD products purchased from our company, or its authorized agents, hereinafter referred to as our company, shall be used only for production purposes by those parties who have duly purchased IPD products. Those who have purchased IPD products shall not use such IPD products in unmodified form for re-sale, loan, or sample shipment for evaluation purposes to any other parties.
- 3) If a party who has duly purchased IPD products subcontracts its production to any other parties, including its subsidiaries or any other third parties inside and/or out of Japan, and the IPD products are consigned to such subcontracting parties thereat, such party is obligated to monitor and control the quantity of IPD products to prevent any of the aforementioned re-sale, loan or sample shipments from taking place.
- 4) In the event that any actual or threatened breach or violation of any of the above mentioned 2) or 3) has occurred or is about to occur, our company will hold all shipments of IPD products and may request the customer to disclose necessary documentation describing the status of our end-users and/or distribution channels.

Note) The products of MIP50□, MIP51□, and MIP7□□ are excluded from above-mentioned precautions, 1) to 3).

Attached table "IPD availability by customer"

Parts No.			Companies/areas to which products can be sold	Companies/areas to which products cannot be sold	Application
MIP0□□□ MIP3□□□ MIP9L□□	MIP1□□ MIP4□□□	MIP2□□□ MIP9A□□	· Japanese companies in Japan · Japanese companies in Asia (50% or more owned)	· Companies in European and American countries · Asian companies in Asia · Other local companies	· For power supply · For DC-DC converter
MIP52□ MIP816/826	MIP55□ MIP9E□□	MIP803/804	· Japanese companies in Japan · Japanese companies in Asia (50% or more owned) · Asian companies in Asia	· Companies in European and American countries · Other local companies	· For power supply · For EL driver · For LED lighting driver
MIP50□	MIP51□	MIP7□□	· No restrictions in terms of contract	· No restrictions in terms of contract	· For lamp driver/ car electronics accessories

Note) If you have any inquiries about sales, contact Corporate Marketing & Sales Division of our company.

The corporation names, logotype and product names written in this book are trademarks or registered trademarks of their corresponding corporations.

Inquiries URL : <https://www.semicon.panasonic.co.jp/semi-spt/general/?lang=en>

Request for your special attention and precautions in using the technical information and semiconductors described in this book

- (1) If any of the products or technical information described in this book is to be exported or provided to non-residents, the laws and regulations of the exporting country, especially, those with regard to security export control, must be observed.
- (2) The technical information described in this book is intended only to show the main characteristics and application circuit examples of the products. No license is granted in and to any intellectual property right or other right owned by Panasonic Corporation or any other company. Therefore, no responsibility is assumed by our company as to the infringement upon any such right owned by any other company which may arise as a result of the use of technical information described in this book.
- (3) The products described in this book are intended to be used for general applications (such as office equipment, communications equipment, measuring instruments and household appliances), or for specific applications as expressly stated in this book. Consult our sales staff in advance for information on the following applications: Special applications (such as for airplanes, aerospace, automotive equipment, traffic signaling equipment, combustion equipment, life support systems and safety devices) in which exceptional quality and reliability are required, or if the failure or malfunction of the products may directly jeopardize life or harm the human body. It is to be understood that our company shall not be held responsible for any damage incurred as a result of or in connection with your using the products described in this book for any special application, unless our company agrees to your using the products in this book for any special application.
- (4) The products and product specifications described in this book are subject to change without notice for modification and/or improvement. At the final stage of your design, purchasing, or use of the products, therefore, ask for the most up-to-date Product Standards in advance to make sure that the latest specifications satisfy your requirements.
- (5) When designing your equipment, comply with the range of absolute maximum rating and the guaranteed operating conditions (operating power supply voltage and operating environment etc.). Especially, please be careful not to exceed the range of absolute maximum rating on the transient state, such as power-on, power-off and mode-switching. Otherwise, we will not be liable for any defect which may arise later in your equipment. Even when the products are used within the guaranteed values, take into the consideration of incidence of break down and failure mode, possible to occur to semiconductor products. Measures on the systems such as redundant design, arresting the spread of fire or preventing glitch are recommended in order to prevent physical injury, fire, social damages, for example, by using the products.
- (6) Comply with the instructions for use in order to prevent breakdown and characteristics change due to external factors (ESD, EOS, thermal stress and mechanical stress) at the time of handling, mounting or at customer's process. When using products for which damp-proof packing is required, satisfy the conditions, such as shelf life and the elapsed time since first opening the packages.
- (7) This book may be not reprinted or reproduced whether wholly or partially, without the prior written permission of our company.

Semiconductor Business Division
Automotive & Industrial Systems Company
Panasonic Corporation

1 Kotari-yakemachi, Nagaokakyo City, Kyoto
617-8520, Japan
Tel : 81-75-951-8151

<http://www.semicon.panasonic.co.jp/en>