

2580, 2585, AND 2588

Data Sheet
29316C+

8-CHANNEL SOURCE DRIVERS

UDN2580A and UDN2585A

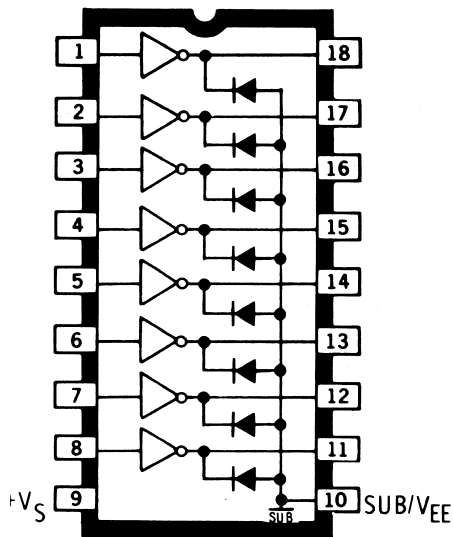

Dwg. No. A-11,359

ABSOLUTE MAXIMUM RATINGS

See next page.

This versatile family of integrated circuits will work with many combinations of logic- and load-voltage levels, meeting interface requirements beyond the capabilities of standard logic buffers. Series UDN2580A and A2580SLW source drivers can drive incandescent, LED, or vacuum fluorescent displays. Internal transient-suppression diodes permit the drivers to be used with inductive loads such as relays, solenoids, dc and stepping motors, and magnetic print hammers.

The Types UDN2580A and A2580SLW are high-current source drivers used to switch the ground ends of loads that are directly connected to a -50 V supply. Typical loads are telephone relays, PIN diodes, and LEDs.

The UDN2585A and A2585SLW are drivers designed for applications requiring low output saturation voltages. Typical loads are low-voltage LEDs and incandescent displays. The eight non-Darlington, 25 V outputs will simultaneously sustain continuous load currents of -120 mA at ambient temperatures to +70°C.

The UDN2588A and A2588SLW have separate logic and driver supply lines. Their eight drivers can serve as an interface between positive logic (TTL, CMOS, PMOS) or negative logic (NMOS) and either negative or split-load supplies to -80 V.

These drivers are packaged in plastic DIPs (suffix A) or surface-mountable wide-body SOICs (suffix LW), and are rated for operation over the temperature range of -20°C to +85°C.

FEATURES

- TTL, CMOS, PMOS, NMOS Compatible
- High Output-Current Rating
- Internal Transient Suppression
- Efficient Input/Output Structure
- Through-Hole and Surface-Mount Packages

The UDN2580A and A2580SLW are last-time buy. Orders accepted until April 15, 2002.
The UDN2588A and A2588SLW are not for new design.

Always order by complete part number, e.g., **UDN2580A**.

2580, 2585, AND 2588 8-CHANNEL SOURCE DRIVERS

ABSOLUTE MAXIMUM RATINGS

at 25°C Free-Air Temperature for any one driver (unless otherwise noted).

	UDN2580A A2580SLW	UDN2585A A2585SLW	UDN2588A A2588SLW
Output Voltage, V_{CE}	50 V	25 V	80 V
Supply Voltage, V_S (ref. sub.)	50 V	25 V	80 V
Supply Voltage, V_{CC} (ref. sub.)	—	—	80 V
Input Voltage, V_{IN} (ref. V_S)	-30 V	-20 V	-30 V
Total Output Current, ($I_C + I_S$)	-500 mA	-250 mA	-500 mA
Substrate Current I_{SUB}	3.0 A	2.0 A	3.0 A

Package Power Dissipation, P_D (single output) 1.0 W
 (total package) See Graph
 Operating Temperature Range, T_A -20°C to +85°C
 Storage Temperature Range, T_S -55°C to +150°C

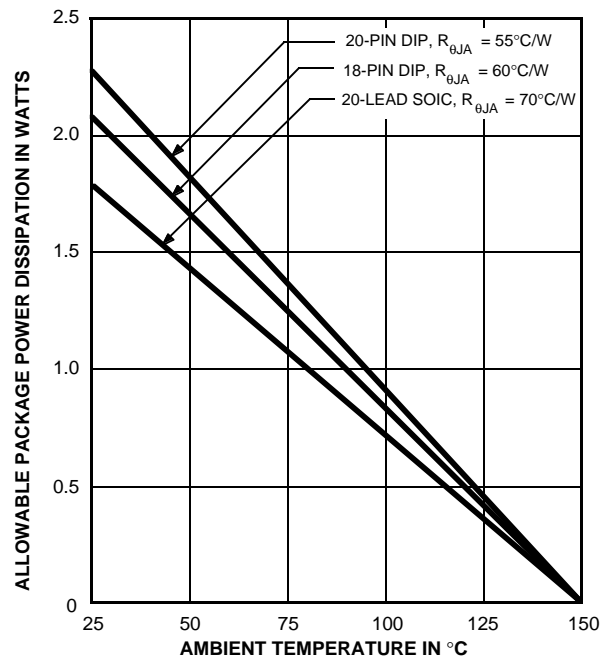

Dwg. GP-022-1

2580, 2585, AND 2588 8-CHANNEL SOURCE DRIVERS

For simplification, these devices are characterized on the following pages with specific voltages for inputs, logic supply (V_S), load supply (V_{EE}), and collector supply (V_{CC}). Typical use of the UDN2580A and A2580SLW is with negative-referenced logic. The more common application of the UDN2585A, A2585SLW, UDN2588A and A2588SLW are with positive-referenced logic supplies. In application, the devices are capable of operation over a wide range of logic and supply voltage levels:

TYPICAL OPERATING VOLTAGES

V_S	$V_{IN(ON)}$	$V_{IN(OFF)}$	V_{CC}	$V_{EE(MAX)}$	Device Types
0 V	-15 V to -3.6 V	-0.5 V to 0 V	NA	-25 V	UDN2585A & A2585SLW
				-50 V	UDN2580A & A2580SLW
+5 V	0 V to +1.4 V	+4.5 V to +5 V	NA	-20 V	UDN2585A & A2585SLW
				-45 V	UDN2580A & A2580SLW
			≤ 5 V	-75 V	UDN2588A & A2588SLW
+12 V	0 V to +8.4 V	+11.5 V to +12 V	NA	-13 V	UDN2585A & A2585SLW
				-38 V	UDN2580A & A2580SLW
			≤ 12 V	-68 V	UDN2588A & A2588SLW
+15 V	0 V to +11.4 V	+14.5 V to +15 V	NA	-10V	UDN2585A & A2585SLW
				-35 V	UDN2580A & A2580SLW
			≤ 15 V	-65 V	UDN2588A & A2588SLW

NOTE: The substrate must be tied to the most negative point in the external circuit to maintain isolation between drivers and to provide for normal circuit operation.

2580, 2585, AND 2588 8-CHANNEL SOURCE DRIVERS

UDN2580A and A2580SLW

ELECTRICAL CHARACTERISTICS at $T_A = +25^\circ\text{C}$, $V_S = 0\text{ V}$, $V_{EE} = -45\text{ V}$ (unless otherwise noted).

Characteristic	Symbol	Test Conditions	Limits		
			Min.	Max.	Units
Output Leakage Current	I_{CEX}	$V_{IN} = -0.5\text{ V}$, $V_{OUT} = V_{EE} = -50\text{ V}$	—	50	μA
		$V_{IN} = -0.4\text{ V}$, $V_{OUT} = V_{EE} = -50\text{ V}$, $T_A = 70^\circ\text{C}$	—	100	μA
Output Sustaining Voltage	$V_{CE(SUS)}$	$V_{IN} = -0.4\text{ V}$, $I_{OUT} = -25\text{ mA}$, Note 1	35	—	V
Output Saturation Voltage	$V_{CE(SAT)}$	$V_{IN} = -2.4\text{ V}$, $I_{OUT} = -100\text{ mA}$	—	1.8	V
		$V_{IN} = -3.0\text{ V}$, $I_{OUT} = -225\text{ mA}$	—	1.9	V
		$V_{IN} = -3.6\text{ V}$, $I_{OUT} = -350\text{ mA}$	—	2.0	V
Input Current	$I_{IN(ON)}$	$V_{IN} = -3.6\text{ V}$, $I_{OUT} = -350\text{ mA}$	—	-500	μA
		$V_{IN} = -15\text{ V}$, $I_{OUT} = -350\text{ mA}$	—	-2.1	mA
	$I_{IN(OFF)}$	$I_{OUT} = -500\text{ }\mu\text{A}$, $T_A = 70^\circ\text{C}$, Note 3	-50	—	μA
Input Voltage	$V_{IN(ON)}$	$I_{OUT} = -100\text{ mA}$, $V_{CE} \leq 1.8\text{ V}$, Note 4	—	-2.4	V
		$I_{OUT} = -225\text{ mA}$, $V_{CE} \leq 1.9\text{ V}$, Note 4	—	-3.0	V
		$I_{OUT} = -350\text{ mA}$, $V_{CE} \leq 2.0\text{ V}$, Note 4	—	-3.6	V
	$V_{IN(OFF)}$	$I_{OUT} = -500\text{ }\mu\text{A}$, $T_A = 70^\circ\text{C}$	-0.2	—	V
Clamp Diode Leakage Current	I_R	$V_R = 50\text{ V}$, $T_A = 70^\circ\text{C}$	—	50	μA
Clamp Diode Forward Voltage	V_F	$I_F = 350\text{ mA}$	—	2.0	V
Input Capacitance	C_{IN}		—	25	pF
Turn-On Delay	t_{PHL}	$0.5 E_{IN}$ to $0.5 E_{OUT}$	—	5.0	μs
Turn-Off Delay	t_{PLH}	$0.5 E_{IN}$ to $0.5 E_{OUT}$	—	5.0	μs

NOTES: 1. Pulsed test, $t_p \leq 300\text{ }\mu\text{s}$, duty cycle $\leq 2\%$.

2. Negative current is defined as coming out of the specified device pin.

3. The $I_{IN(OFF)}$ current limit guarantees against partial turn-on of the output.

4. The $V_{IN(ON)}$ voltage limit guarantees a minimum output source current per the specified conditions.

5. The substrate must always be tied to the most negative point and must be at least 4.0 V below V_S .

PARTIAL SCHEMATIC

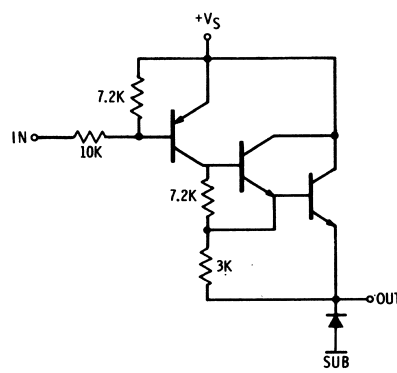

Dwg. No. A-11,358

UDN2580A

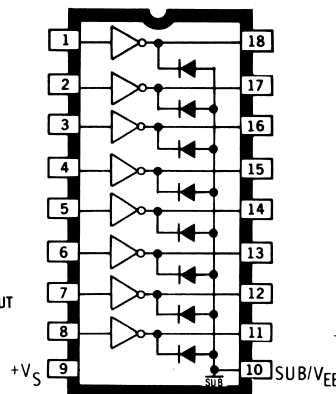

Dwg. No. A-11,359

A2580SLW

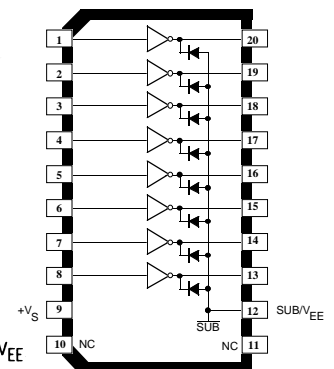

Dwg. PP-064

2580, 2585, AND 2588 8-CHANNEL SOURCE DRIVERS

UDN2585A and A2585SLW

ELECTRICAL CHARACTERISTICS at $T_A = +25^\circ\text{C}$, $V_S = 0\text{ V}$, $V_{EE} = -20\text{ V}$ (unless otherwise noted).

Characteristic	Symbol	Test Conditions	Limits		
			Min.	Max.	Units
Output Leakage Current	I_{CEX}	$V_{IN} = -0.5\text{ V}$, $V_{OUT} = V_{EE} = -25\text{ V}$	—	50	μA
		$V_{IN} = -0.4\text{ V}$, $V_{OUT} = V_{EE} = -25\text{ V}$, $T_A = 70^\circ\text{C}$	—	100	μA
Output Sustaining Voltage	$V_{CE(SUS)}$	$V_{IN} = -0.4\text{ V}$, $I_{OUT} = -25\text{ mA}$, Note 1	15	—	V
Output Saturation Voltage	$V_{CE(SAT)}$	$V_{IN} = -4.6\text{ V}$, $I_{OUT} = -60\text{ mA}$	—	1.1	V
		$V_{IN} = -4.6\text{ V}$, $I_{OUT} = -120\text{ mA}$	—	1.2	V
Input Current	$I_{IN(ON)}$	$V_{IN} = -4.6\text{ V}$, $I_{OUT} = -120\text{ mA}$	—	-1.6	mA
		$V_{IN} = -14.6\text{ V}$, $I_{OUT} = -120\text{ mA}$	—	-5.0	mA
Input Voltage	$V_{IN(ON)}$	$I_{OUT} = -120\text{ mA}$, $V_{CE} \leq 1.2\text{ V}$, Note 3	—	-4.6	V
	$V_{IN(OFF)}$	$I_{OUT} = -100\text{ }\mu\text{A}$, $T_A = 70^\circ\text{C}$	-0.4	—	V
Clamp Diode Leakage Current	I_R	$V_R = 25\text{ V}$, $T_A = 70^\circ\text{C}$	—	50	μA
Clamp Diode Forward Voltage	V_F	$I_F = 120\text{ mA}$	—	2.0	V
Input Capacitance	C_{IN}		—	25	pF
Turn-On Delay	t_{PHL}	$0.5 E_{IN}$ to $0.5 E_{OUT}$	—	5.0	μs
Turn-Off Delay	t_{PLH}	$0.5 E_{IN}$ to $0.5 E_{OUT}$	—	5.0	μs

NOTES: 1. Pulsed test, $t_p \leq 300\text{ }\mu\text{s}$, duty cycle $\leq 2\%$.

2. Negative current is defined as coming out of the specified device pin.

3. The $V_{IN(ON)}$ voltage limit guarantees a minimum output source current per the specified conditions.

4. The substrate must always be tied to the most negative point and must be at least 4.0 V below V_S .

PARTIAL SCHEMATIC

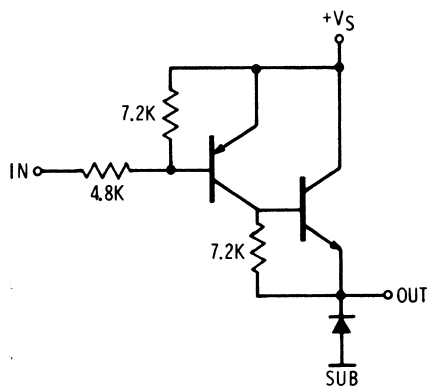

Dwg. No. A-11,360

UDN2585A

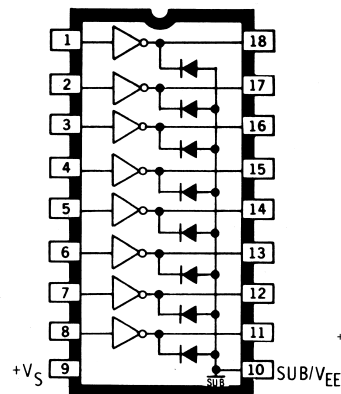

Dwg. No. A-11,359

A2585SLW

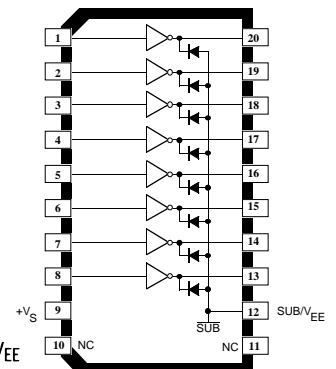

Dwg. PP-064

2580, 2585, AND 2588 8-CHANNEL SOURCE DRIVERS

UDN2588A and A2588SLW ELECTRICAL CHARACTERISTICS at $T_A = +25^\circ\text{C}$, $V_S = 5.0\text{ V}$, $V_{CC} = 5.0\text{ V}$, $V_{EE} = -40\text{ V}$ (unless otherwise noted).

Characteristic	Symbol	Test Conditions	Limits		
			Min.	Max.	Units
Output Leakage Current	I_{CEX}	$V_{IN} \geq 4.5\text{ V}$, $V_{OUT} = V_{EE} = -75\text{ V}$	—	50	μA
Output Sustaining Voltage	$V_{CE(SUS)}$	$V_{IN} \geq 4.6\text{ V}$, $V_{EE} = -70\text{ V}$, $I_{OUT} = -25\text{ mA}$, Note 1	50	—	V
Output Saturation Voltage	$V_{CE(SAT)}$	$V_{IN} = 2.6\text{ V}$, $I_{OUT} = -100\text{ mA}$, Ref. V_{CC}	—	1.8	V
		$V_{IN} = 2.0\text{ V}$, $I_{OUT} = -225\text{ mA}$, Ref. V_{CC}	—	1.9	V
		$V_{IN} = 1.4\text{ V}$, $I_{OUT} = -350\text{ mA}$, Ref. V_{CC}	—	2.0	V
Input Current	$I_{IN(ON)}$	$V_{IN} = 1.4\text{ V}$, $I_{OUT} = -350\text{ mA}$	—	-500	μA
		$V_S = 15\text{ V}$, $V_{EE} = -30\text{ V}$, $V_{IN} = 0\text{ V}$, $I_{OUT} = -350\text{ mA}$	—	-2.1	mA
	$I_{IN(OFF)}$	$I_{OUT} = -500\text{ }\mu\text{A}$, $T_A = 70^\circ\text{C}$, Note 3	-50	—	μA
Input Voltage	$V_{IN(ON)}$	$I_{OUT} = -100\text{ mA}$, $V_{CE} \leq 1.8\text{ V}$, Note 4	—	2.6	V
		$I_{OUT} = -225\text{ mA}$, $V_{CE} \leq 1.9\text{ V}$, Note 4	—	2.0	V
		$I_{OUT} = -350\text{ mA}$, $V_{CE} \leq 2.0\text{ V}$, Note 4	—	1.4	V
	$V_{IN(OFF)}$	$I_{OUT} = -500\text{ }\mu\text{A}$	4.8	—	V
Clamp Diode Leakage Current	I_R	$V_R = 80\text{ V}$	—	50	μA
Clamp Diode Forward Voltage	V_F	$I_F = 350\text{ mA}$	—	2.0	V
Input Capacitance	C_{IN}		—	25	pF
Turn-On Delay	t_{PLH}	$0.5 E_{IN}$ to $0.5 E_{OUT}$	—	5.0	μs
Turn-Off Delay	t_{PLH}	$0.5 E_{IN}$ to $0.5 E_{OUT}$	—	5.0	μs

- NOTES: 1. Pulsed test, $t_p \leq 300\text{ }\mu\text{s}$, duty cycle $\leq 2\%$.
 2. Negative current is defined as coming out of the specified device pin.
 3. The $I_{IN(OFF)}$ current limit guarantees against partial turn-on of the output.
 4. The $V_{IN(ON)}$ voltage limit guarantees a minimum output source current per the specified conditions.
 5. The substrate must always be tied to the most negative point and must be at least 4.0 V below V_S .
 6. V_{CC} must be equal to or less positive than V_S .

PARTIAL SCHEMATIC

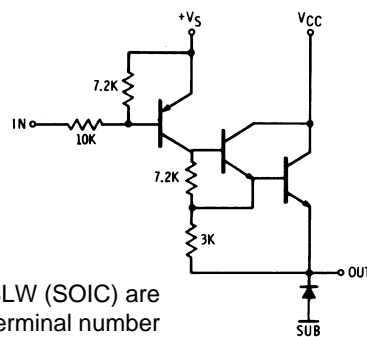

Dwg. No. A-11,361

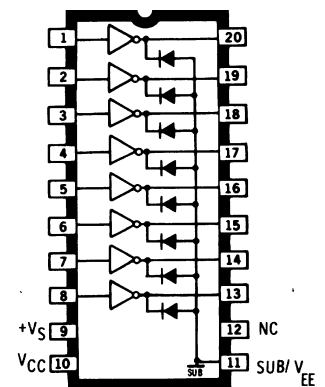

Dwg. No. A-11,357

Note the UDN2588A (DIP) and the A2588SLW (SOIC) are electrically identical and share a common terminal number assignment.

2580, 2585, AND 2588 8-CHANNEL SOURCE DRIVERS

ALLOWABLE PEAK COLLECTOR CURRENT AT 50°C AS A FUNCTION OF DUTY CYCLE

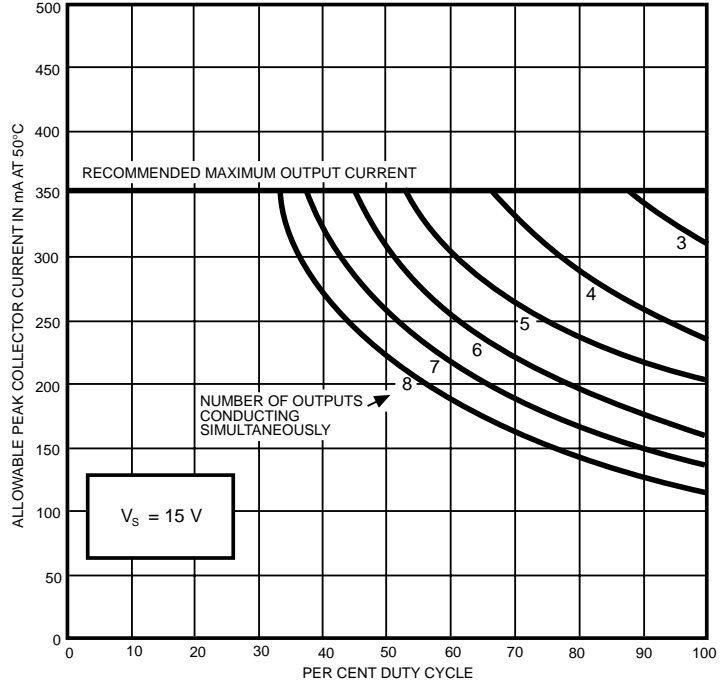

Dwg. No. A-11,107B

ALLOWABLE PEAK COLLECTOR CURRENT AT 70°C AS A FUNCTION OF DUTY CYCLE

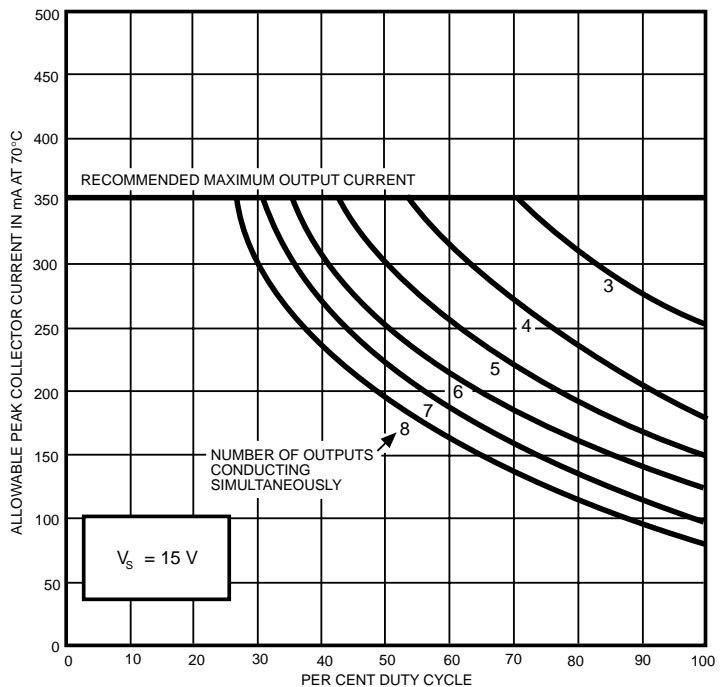

Dwg. No. A-11,108B

2580, 2585, AND 2588 8-CHANNEL SOURCE DRIVERS

TYPICAL APPLICATIONS

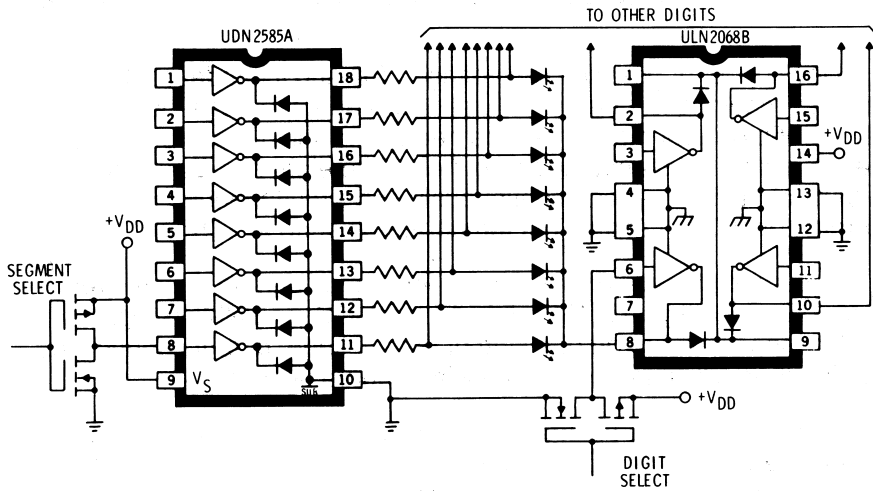

Dwg. No. B-1458A

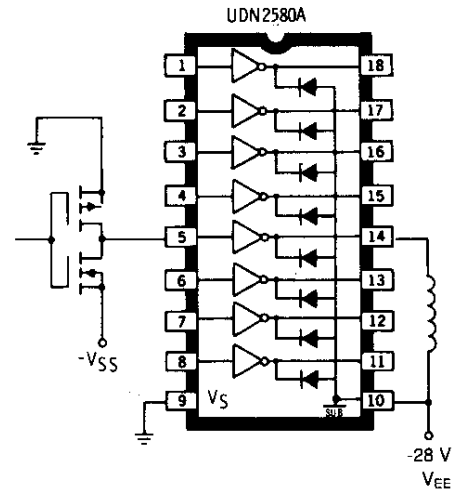

Dwg. No. A-11,356

COMMON-CATHODE LED DRIVER

TELECOMMUNICATIONS
RELAY DRIVER
(Negative Logic)

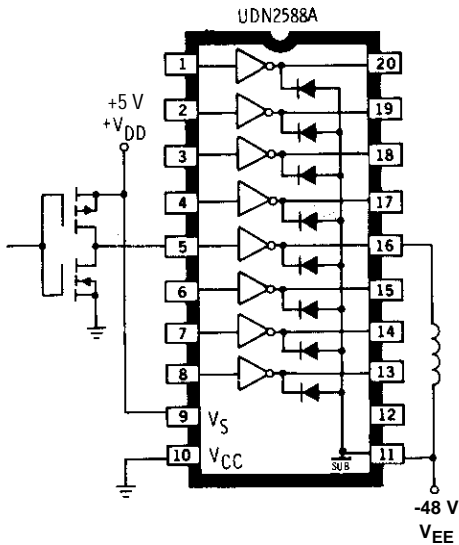

Dwg. No. A-11,362A

TELECOMMUNICATIONS RELAY DRIVER
(Positive Logic)

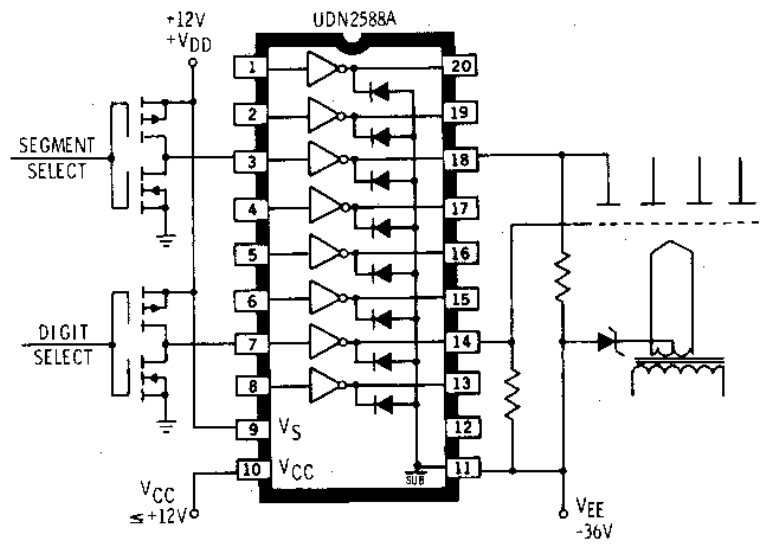

Dwg. No. A-11,363

VACUUM-FLUORESCENT DISPLAY DRIVER
(Split Supply)

2580, 2585, AND 2588 8-CHANNEL SOURCE DRIVERS

UDN2580A and UDN2585A

Dimensions in Inches
(controlling dimensions)

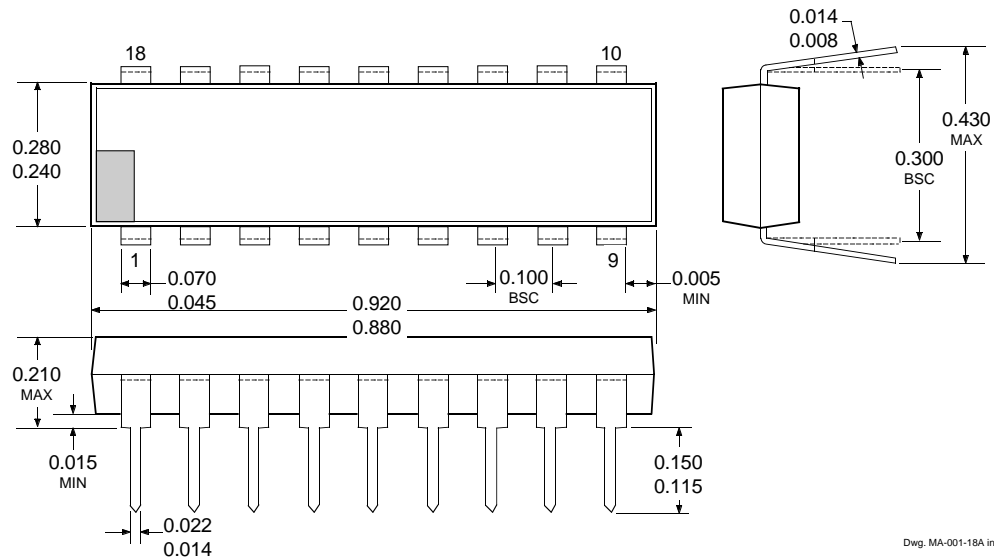

Dimensions in Millimeters
(for reference only)

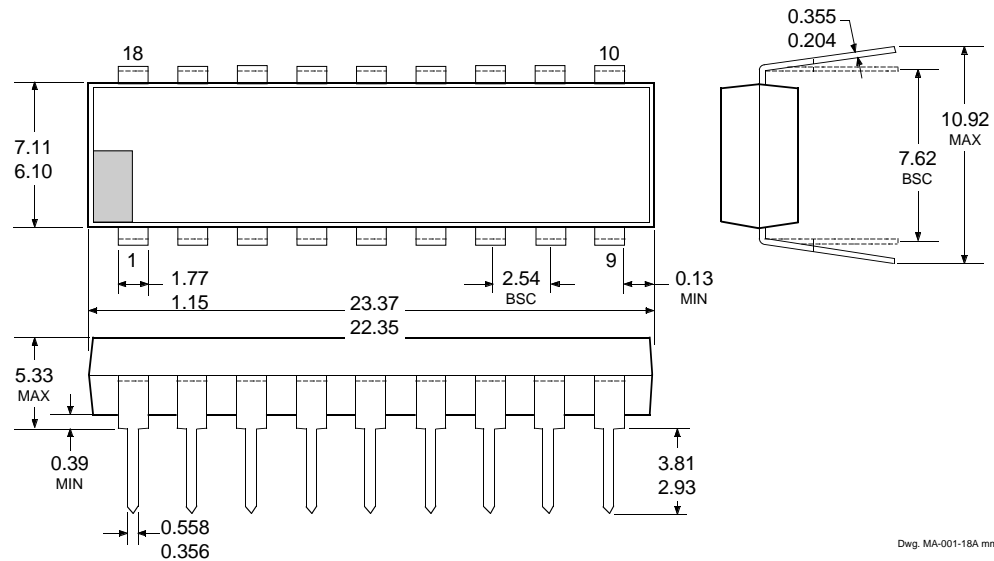

- NOTES: 1. Exact body and lead configuration at vendor's option within limits shown.
 2. Lead spacing tolerance is non-cumulative.
 3. Lead thickness is measured at seating plane or below.
 4. Supplied in standard sticks/tubes of 21 devices.

2580, 2585, AND 2588 8-CHANNEL SOURCE DRIVERS

A2580SLW, A2585SLW, and A2588SLW

(add TR to part number for tape and reel)

Dimensions in Inches (for reference only)

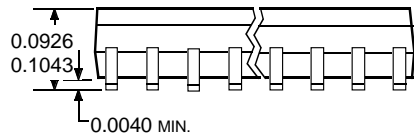
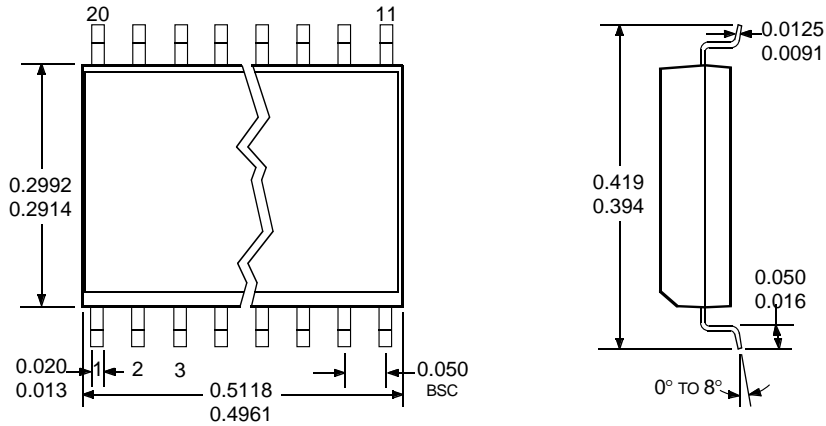

Dwg. MA-008-20 in

Dimensions in Millimeters (controlling dimensions)

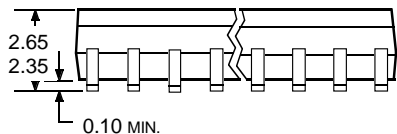
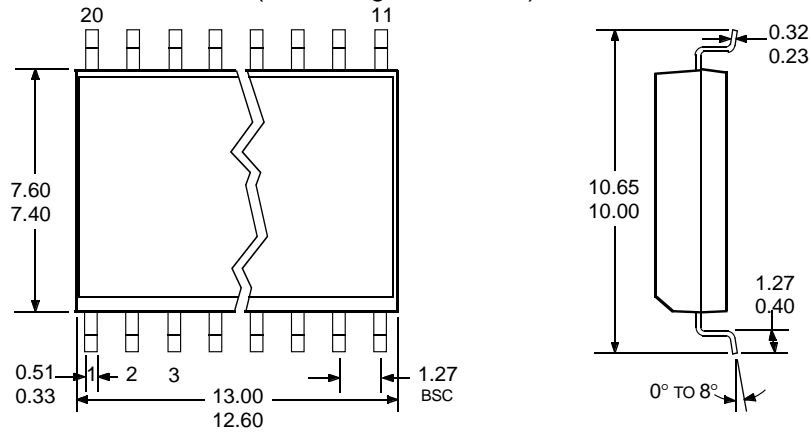

Dwg. MA-008-20 mm

- NOTES: 1. Exact body and lead configuration at vendor's option within limits shown.
 2. Lead spacing tolerance is non-cumulative.
 3. Supplied in standard sticks/tubes of 37 devices or add "TR" to part number for tape and reel.

2580, 2585, AND 2588 8-CHANNEL SOURCE DRIVERS

UDN2588A

Dimensions in Inches
(controlling dimensions)

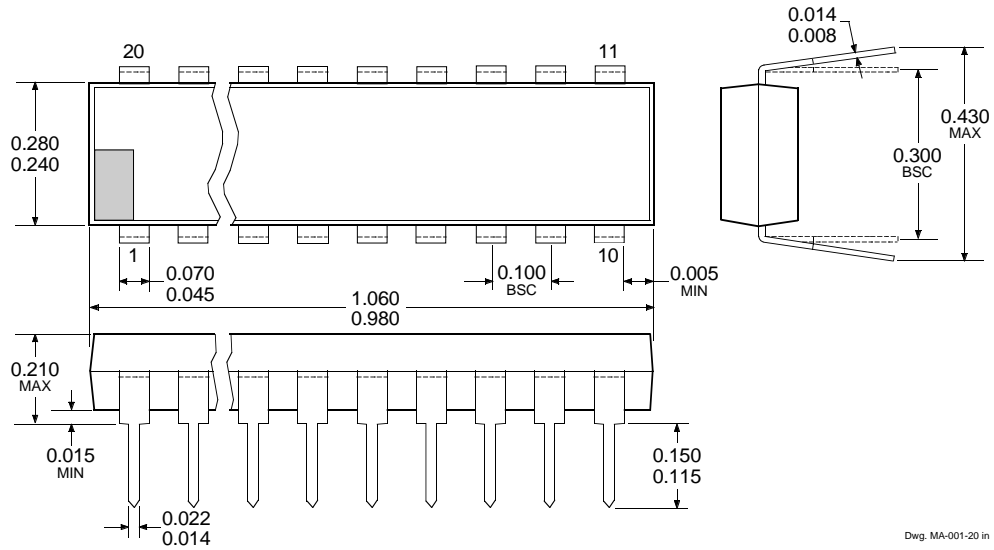

Dimensions in Millimeters
(for reference only)

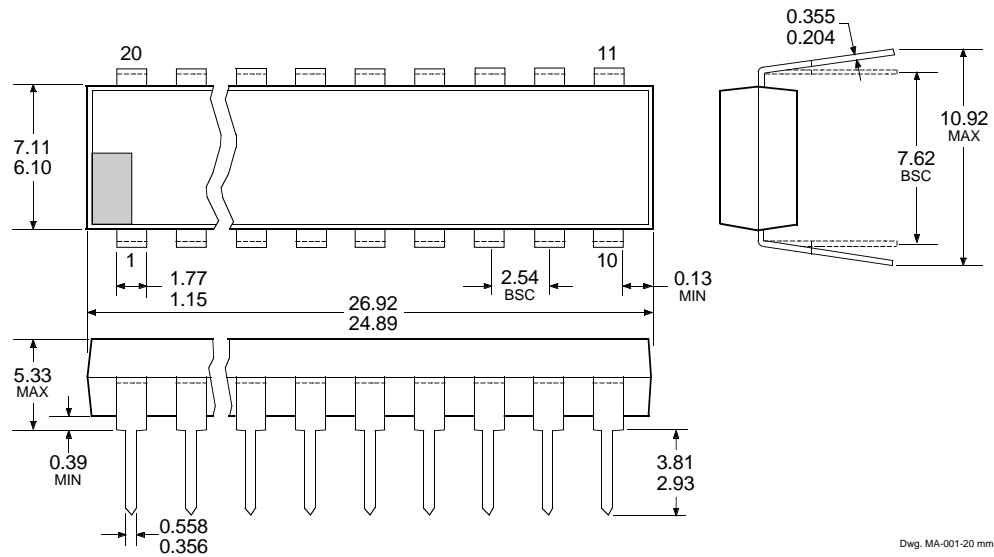

- NOTES: 1. Exact body and lead configuration at vendor's option within limits shown.
 2. Lead spacing tolerance is non-cumulative.
 3. Lead thickness is measured at seating plane or below..
 4. Supplied in standard sticks/tubes of 18 devices.

2580, 2585, AND 2588
8-CHANNEL
SOURCE DRIVERS

The products described here are manufactured under one or more U.S. patents or U.S. patents pending.

Allegro MicroSystems, Inc. reserves the right to make, from time to time, such departures from the detail specifications as may be required to permit improvements in the performance, reliability, or manufacturability of its products. Before placing an order, the user is cautioned to verify that the information being relied upon is current.

Allegro products are not authorized for use as critical components in life-support devices or systems without express written approval.

The information included herein is believed to be accurate and reliable. However, Allegro MicroSystems, Inc. assumes no responsibility for its use; nor for any infringement of patents or other rights of third parties which may result from its use.