

Helping Customers Innovate, Improve & Grow



Vectron offers a High Temperature Crystal Oscillator (PX-610) product platform for extreme environment applications. In addition to its wide operating temperature range, PX-610 HTXO is also ideal for high shock & vibration applications. The foot print of the PX-610 design is based on an industry standard TO-39 package.

Vectron's vertical integration in the following technical areas ensures the ability to design and manufacture state of the art high temperature frequency control products:

- BAW & SAW Design & Fabrication to produce high quality resonators.
- RF Oscillator Circuit Design.
- Established 250°C High Temperature Electronics Packaging Expertise.
- Established 250°C High Temperature Electronics Assembly & Test Expertise.
- Environmental Screening.

Vectron's manufacturing processes, from quartz resonator fabrication to oscillator electronics assembly and test, are painstakingly controlled via ISO and SPC procedures. Vectron fabricates high temperature quartz resonators using proprietary manufacturing processes designed specifically for high temperature and harsh environment applications. In order to ensure high reliability in the field, critical electrode metallization and testing processes are conducted inside state-of-the-art Class 1K cleanrooms, while oscillator assembly is conducted in Class 10K cleanrooms. All high temperature oscillators are 100% tested before delivery.

Features

- **Continuous operating temperature range -55°C to 230°C**
- **Low jitter and phase noise**
- **1.8Vdc, 2.5Vdc, 3.3Vdc or 5Vdc operation**
- **Compliant crystal mount for high shock & vibration**
- **Output frequency 32kHz to 40MHz standard**
- **0.380" diameter x 0.185" high resistance welded 3 pin TO-39 package**
- **RoHS Compliant**
- **Made in USA**

Applications

- Oil / Gas downhole tool
- Geophysical services
- High temperature industrial process control
- Extended temperature Military/Aerospace
- Avionics
- Engine control



Block Diagram

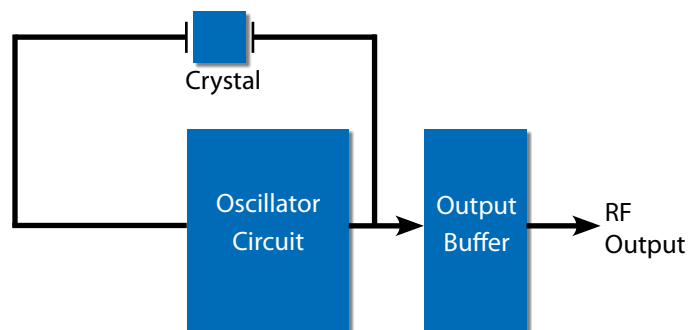

Performance Specifications

Specification Parameters	Values	
Frequency Range	32kHz to 40MHz	
Supply (Vdd)	+5.0Vdc ±5% (D) +3.3Vdc ±5% (E)	+2.5Vdc ±5% (H) +1.8Vdc ±5% (J)
Current	5mA typical @ 20MHz, 3.3V (low current option is available, consult factory)	
Level "0" & "1"	<0.4V / >Vdd - 0.5V	
Output	HCMOS compatibility (A)	
Rise & Fall Time	1ns typical / 5ns Max	
Symmetry	45/55%	
Operating Temperature	0°C to +150°C (1) -20°C to +180°C (Z) -55°C to +180°C (Y)	0°C to +200°C (2) 0°C to +230°C (3) (other custom temperature ranges are available, consult factory)
Jitter (12kHz - 20MHz)	<0.5ps	
Phase Noise (Typical @40MHz, HCMOS, 3.3V)	10Hz -80 dBc/Hz 100Hz -120 dBc/Hz 1kHz -140 dBc/Hz	10kHz -155 dBc/Hz 100kHz -160 dBc/Hz 1MHz -160 dBc/Hz
Temperature Stability	±40ppm (J) ±100ppm (S) ±150ppm (U)	±250ppm (W) ±350ppm (Y)
Package Size (mm)	0.38" x .0185" 3 pin TO-39 resistance weld package	
Storage Temperature	-55°C to +125°C	

Environmental Compliance

Vibration-Sine	20g, 10Hz to 2kHz Sine	MIL-STD-202 Method 204 Condition D
Vibration-Random	20grms, 10Hz to 2kHz Random	MIL-STD-202 Method 214 Condition I-F
Shock	1000g, 0.5ms	MIL-STD-202 Method 213 Condition E
Seal Test	Fine	MIL-STD-883 Method 1014 Condition A2
Seal Test	Gross	MIL-STD-202 Method 112 Condition D
Temperature Cycling	10 Cycles minimum	MIL-STD-883 Method 1010 Condition B
Acceleration	5000g Y1 axis	MIL-STD-883 Method 2001 Condition A

Physical Specifications

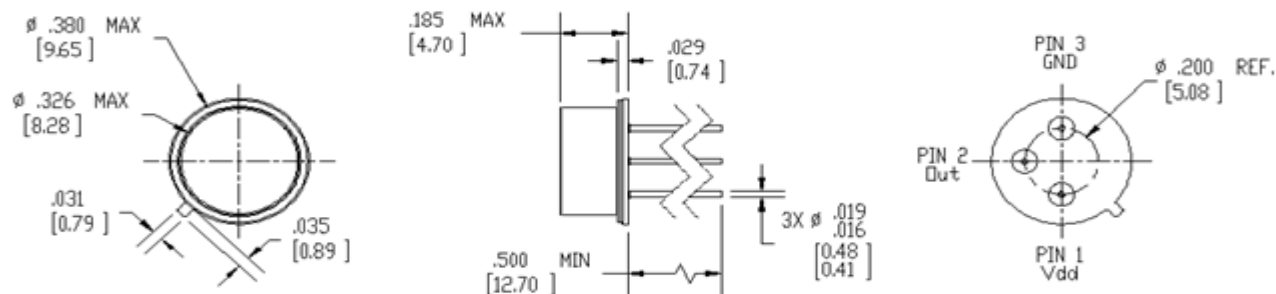

Pin	Function
1	Vdd Power Supply Voltage
2	RF Output
3	Case & Electrical Ground

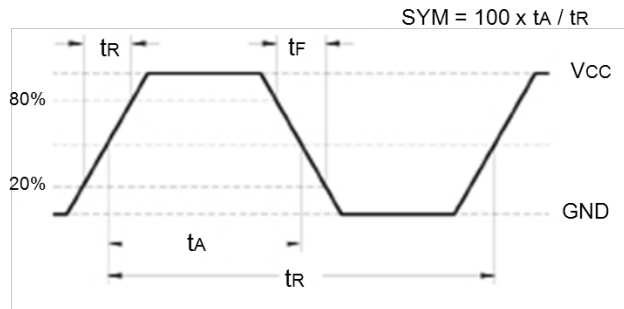

Typical Phase Noise Performance

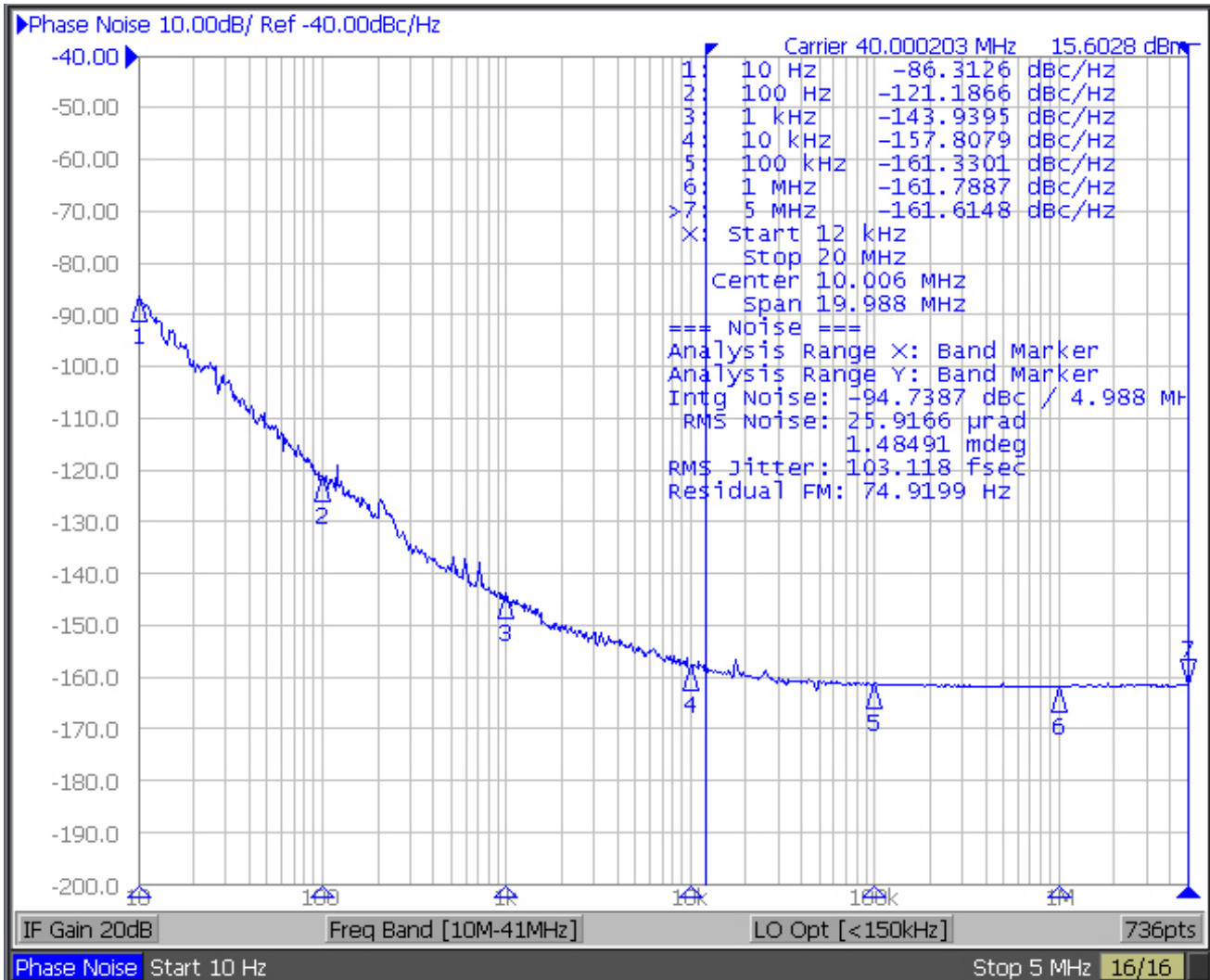

Standard Frequency List

32.768kHz	512.000kHz	1.000MHz	1.024MHz	2.000MHz	2.048MHz	3.6864MHz	4.000MHz
4.096MHz	4.9152MHz	5.000MHz	7.3728MHz	7.500MHz	8.000MHz	8.192MHz	10.000MHz
12.000MHz	16.000MHz	16.384MHz	20.000MHz	24.000MHz	32.000MHz	32.768MHz	40.000MHz
48.000MHz							

Ordering Information

PX - 610 0 - D A Y - W X X X - 10M000000

Product Family
Crystal Oscillator

Package Type
610: 3 pin TO-39

Factory Use

Supply Voltage

- D: 5.0V ±5%
- E: 3.3V ±5%
- H: 2.5V ±5%
- J: 1.8V ±5%

Output

A: HCMOS/ACMOS

Temperature Range

- 1: 0°C to 150°C
- Z: -20°C to 180°C
- Y: -55°C to 180°C
- 2: 0°C to 200°C
- 5: -55°C to 200°C
- 3: 0°C to 230°C
- 6: -55°C to 230°C

Frequency

Factory Use

Factory Use

Enable

- A: Enable Hi, Tristate
- X: No Enable

Temp Stability (PX)

- J: ± 40ppm
- S: ± 100ppm
- U: ± 150ppm
- V: ± 200ppm
- W: ± 250ppm
- Y: ± 350ppm

Temperature Range and Stability Table

Temp Range	Temp Stability	PX-570
1: 0°C to 150°C	J: ± 40ppm	Tight Stability
	S: ± 100ppm	Standard
	U: ± 150ppm	Standard
	W: ± 250ppm	Standard
Z: -20°C to 180°C	J: ± 40ppm	Tight Stability
	S: ± 100ppm	Tight Stability
	U: ± 150ppm	Standard
	W: ± 250ppm	Standard
Y: -55°C to 180°C	S: ± 100ppm	Tight Stability
	U: ± 150ppm	Standard
	W: ± 250ppm	Standard
2: 0°C to 200°C	S: ± 100ppm	Tight Stability
	U: ± 150ppm	Tight Stability
	V: ± 200ppm	Standard
	W: ± 250ppm	Standard
5: -55°C to 200°C	S: ± 100ppm	Tight Stability
	U: ± 150ppm	Tight Stability
	V: ± 200ppm	Standard
	W: ± 250ppm	Standard
3: 0°C to 230°C	V: ± 200ppm	Tight Stability
	W: ± 250ppm	Tight Stability
	Y: ± 350ppm	Standard
6: -55°C to 230°C	V: ± 200ppm	Tight Stability
	W: ± 250ppm	Tight Stability
	Y: ± 350ppm	Standard

**Note: not all combination of options are available.
Other specifications may be available upon request.*

This Page Intentionally Left Blank

For Additional Information, Please Contact

USA:

Vectron International
267 Lowell Road, Unit 102
Hudson, NH 03051
Tel: 1.888.328.7661
Fax: 1.888.329.8328

Europe:

Vectron International
Landstrasse, D-74924
Neckarbischofsheim, Germany
Tel: +49 (0) 3328.4784.17
Fax: +49 (0) 3328.4784.30

Asia:

Vectron International
68 Yin Cheng Road(C), 22nd Floor
One LuJiaZui
Pudong, Shanghai 200120, China
Tel: 86.21.6194.6886
Fax: 86.21.6194.6699

Disclaimer

Vectron International reserves the right to make changes to the product(s) and or information contained herein without notice. No liability is assumed as a result of their use or application. No rights under any patent accompany the sale of any such product(s) or information.