

SED1240 Series

LCD Controller Driver

■ DESCRIPTION

The dot-matrix LCD controller driver SED1240 series is designed to display characters and capable of displaying up to 64 characters, 6 user-defined characters and 160 symbols using 4- or 8-bit or serial data sent from the microcomputer.

The built-in character generator ROM is equipped with up to 544 types of character fonts, which consist of 5×8 dots respectively, enabling the maximum consecutive calls of 256 types by switching register options. This enables various character fonts to be applied to each purpose or country, etc., further widening the use of this IC. The user-defined character RAM for 6 characters of 5×8 dots is also built in, enabling display of high degree of freedom through the symbol register.

Thanks to its ultra-low power consumption, sleep and standby modes, it can operate handy equipment with the minimum power demand.

■ FEATURES

- Built-in display data RAM: 80 characters + 6 user-defined characters + 160 symbols
- CGROM (up to 544 characters), CGRAM (6 characters) and symbol register (160 symbols)
- Number of displaying digits and lines
 - <Normal mode>
 - 1) (16 digits) \times 4 lines + 160 symbols + 10 static icons (SED1240)
 - 2) (16 digits) \times 3 lines + 160 symbols + 10 static icons (SED1241)
 - 3) (16 digits) \times 2 lines + 160 symbols + 10 static icons (SED1242)
 - <Standby mode>
 - 1) 10 static icons (SED1240)
 - 2) 10 static icons (SED1241)
 - 3) 10 static icons (SED1242)
- Vertically-double size displaying function
- Line vertical scrolling function
- Line blinking function
- Symbol blinking function
- On-chip CR oscillation circuit (C and R on chip)
- External clock input available
- High-speed MPU interface
 - Compatible with both 68- and 80-series MPUs
 - 4- and 8-bit interface available
- Serial interface available
- Character font: 5×8 dots
- Duty ratio:
 - 1) 1/34 (SED1240)
 - 2) 1/26 (SED1241)
 - 3) 1/18 (SED1242)
- Simple command setting
- Built-in liquid crystal drive power circuit
 - Power boosting and voltage regulating circuits, voltage followers ($\times 4$), bias switching command available, built-in resistance for power regulating circuit
- Built-in electronic volume function
- Low power demand:
 - 80 μ A max. (during normal operation (display): Including the internal power supply operating current)
 - 500 μ A max. (during normal operation (access): f_{cyc} = 200kHz, including the internal power supply operating current)
 - 20 μ A max. (in standby mode: Oscillation = On, power = Off, static icon display)
 - 5 μ A max. (in sleep mode: Oscillation = Off, power = Off, display = Off)
- Power
 - V_{DD} – V_{SS}: –1.8 V to –5.5 V
 - V_{DD} – V₅: –5.5 V to –16.0 V
- Wide operating temperature range: T_a = –30 to 85°C
- CMOS process
- Pad pitch: 90 μ m (min.)
- Package to be shipped
 - Chip (gold bump model): SED124*D**
 - TCP: SED124*T**
- This IC is not designed to resist radiation or intense light noise.

SED1240 Series

■ BLOCK DIAGRAM

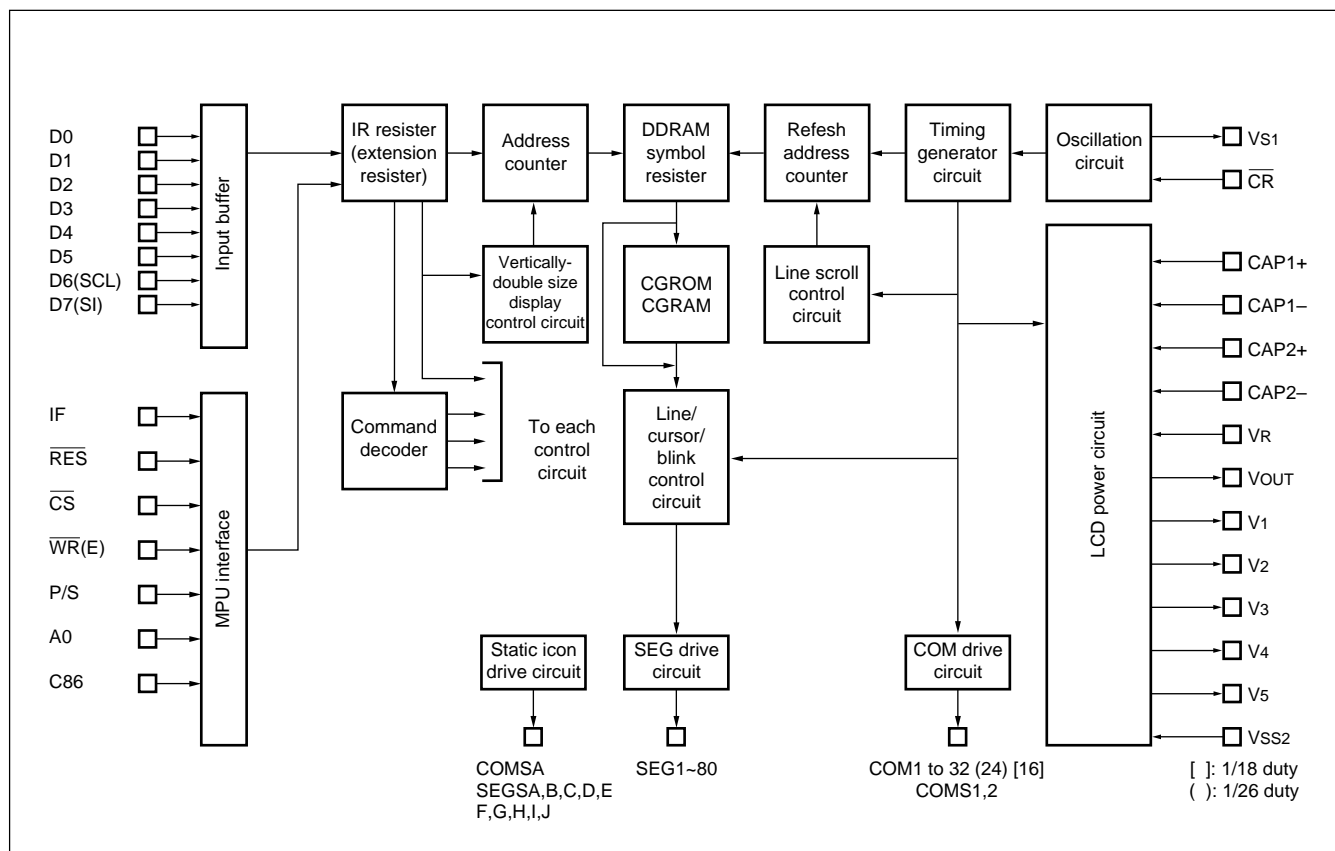

■ PAD LAYOUT

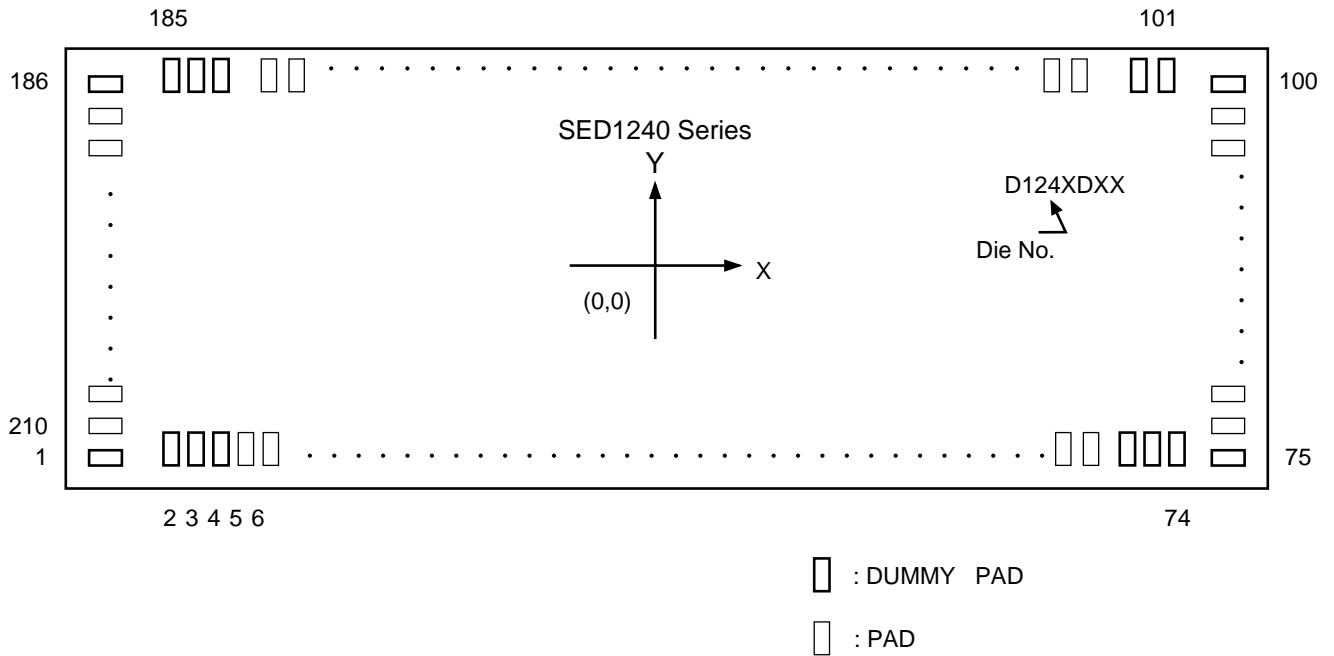

SED124****
 ↑ CGROM pattern change corresponding digit

- Chip size: 8.70 mm × 2.80 mm
- Pad pitch: 90 μm (min.)
- Chip thickness (reference): 625 ± 50 μm (SED124*D**)
- Au bump specifications
 - Bump size: 60.0 μm × 81.5 μm (A type)
 - 81.5 μm × 60.0 μm (B type)
 - 85.0 μm × 85.0 μm (C type)
 - 60.0 μm × 85.0 μm (D type)
- Bump height (reference): 22.5 μm ± 5.5 μm
 (refer to the pad coordinate diagram for the bump types)

SED1240 Series

■ ABSOLUTE MAXIMUM RATINGS

Parameter		Symbol	Rating	Unit
Supply voltage (1)		V _{SS}	-7.0 to +0.3	V
Supply voltage (2)	Double boosting Triple boosting	V _{SS2}	-7.0 to +0.3 -7.0 to +0.3 -6.0 to +0.3	V
Supply voltage (2)		V ₅ , V _{OUT}	-18.0 to +0.3	V
Supply voltage (3)		V ₁ , V ₂ , V ₃ , V ₄	V ₅ to +0.3	V
Input voltage		V _{IN}	V _{SS} -0.3 to +0.3	V
Output voltage		V _O	V _{SS} -0.3 to +0.3	V
Operating temperature		T _{opr}	-30 to +85	°C
Storing temperature	TCP	T _{str}	-55 to +100	°C
	Bare chip		-65 to +125	

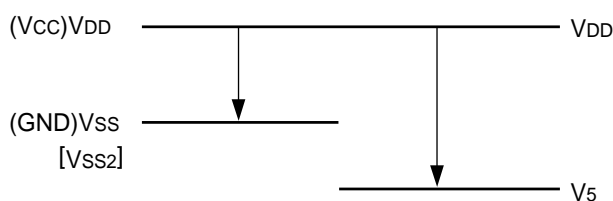

Notes

1. All voltages refer to V_{DD} as 0 V.
2. For voltages V₁, V₂, V₃ and V₄, be sure to keep the conditions of "V_{DD} ≥ V₁ ≥ V₂ ≥ V₃ ≥ V₄ ≥ V₅" and "V_{DD} ≥ (V_{SS}, V_{SS2}) ≥ V₅ ≥ V_{OUT}".
3. If the LSI is used outside the absolute maximum ratings, it may permanently break. Use under the electrical characteristics conditions is recommended for normal operation, otherwise, the LSI may malfunction, disadvantageously affecting its reliability.

DC CHARACTERISTICS

V_{SS} = -3.6 V to -2.4 V and T_a = -30 to 85°C unless otherwise specified.

Parameter		Symbol	Condition		Rating			Units	Pin used
					Min.	Typ.	Max.		
Supply voltage (1)	Recommended operation	V _{SS}	—		-3.6	-3.0	-2.4	V	V _{SS} *1
	Data holding voltage		—		-5.5	—	-1.8		
Supply voltage (2)	Recommended operation	V _{SS2}	—		-3.6	—	-2.4	V	V _{SS2} *2, *9
	Operation enabled		—		-5.5	—	-1.8		
Supply voltage (3)	Recommended operation	V ₅	—		-16.0	—	-5.0	V	V ₅ *2
	Operation enabled	V ₁ , V ₂	—		0.6 × V ₅	—	V _{DD}	V	V ₁ , V ₂
	Operation enabled	V ₃ , V ₄	—		V ₅	—	0.4 × V ₅	V	V ₃ , V ₄
High-level input voltage		V _{IHC}	—		0.2 × V _{SS}	—	V _{DD}	V	*3
Low-level input voltage		V _{ILC}	—		V _{SS}	—	0.8 × V _{SS}	V	*3
Input leakage current		I _{LI}	V _{IN} = V _{DD} or V _{SS}		-1.0	—	1.0	μA	*3
Liquid crystal driver ON resistance		R _{ON}	T _a = 25°C ΔV = 0.1 V	V ₅ = -7.0 V	—	20	4.0	kΩ	COM, SEG *4
Static current consumption		I _{DDQ}	—		—	0.1	5.0	μA	V _{DD}
Dynamic current consumption		I _{DD}	During display	V ₅ = -6 V, unloaded	—	—	80	μA	V _{DD} *5
			In standby mode	Oscillation = On, power = Off	—	—	20	μA	V _{DD} *6
			In sleep mode	Oscillation = On, power = Off	—	—	5	μA	V _{DD}
			During access	f _{cyc} = 200 kHz	—	—	500	μA	V _{DD} *7
Input pin capacity		C _{IN}	T _a = 25°C, f = 1 MHz		—	5.0	8.0	pF	*3

Frame frequency	f _{FR}	T _a = 25°C, V _{SS} = -3.0 V	70	100	130	Hz	*10
External clock frequency	f _{CK}	2-lines display (SED1242)	—	28.8	—	kHz	*10, *11
	f _{CK}	3-lines display (SED1241)	—	41.6	—	kHz	*10, *11
	f _{CK}	4-lines display (SED1240)	—	54.4	—	kHz	*10, *11

Minimum reset pulse width	t _{RW}	—	10	—	—	μs	*8
Reset start time	t _{RES}	—	50	—	—	ns	*8

Dynamic System

Built-in power supply	Input voltage	V _{SS2}	Double boosting	-7.0	—	-1.8	V	V _{SS2}
			Triple boosting	-6.0	—	-1.8		
	Boosting output voltage	V _{OUT}	Double boosting	-11.0	—	—	V	V _{OUT}
			Triple boosting	-16.5	—	—		
	Voltage follower operating voltage	V ₅	—	-16.0	—	-4.5	V	—
Reference voltage	V _{REG}	T _a = 25°C	-2.06	-2.0	-1.94	V	—	

SED1240 Series

*1: Although a wide operating voltage range is guaranteed, it is not guaranteed in case of sudden voltage change during MPU access.

The low supply voltage data holding characteristics apply in the sleep mode, where MPU access is disabled.

*2: Be sure for supply voltage V_{SS2} not to exceed the operating voltage ranges for V_{out} and V_5 during triple boosting.

*3: D0 to D5, D6 (SCL), D7 (SI), A0, \overline{RES} , \overline{CS} , \overline{WR} (E), P/S, IF, C86 and CK.

*4: The resistance value when a voltage of 0.1 V is applied between output pins (SEG_n , $SEGS_n$, COM_n and $COMS_n$) and each power supply pin (V_1 , V_2 , V_3 and V_4). Specified in the range of supply voltage (2).

$$R_{ON} = 0.1 \text{ V} / \Delta I$$

(where ΔI = Current flowing when 0.1 V is applied between the power supply and the output)

*5: Applies when there is no access from the MPU, the built-in power and oscillation circuits are operating and $HPM = 0$ while the following character is displayed.

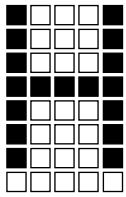

*6: Applies when the built-in power circuit is turned off and the oscillation circuit turned on in the standby mode.

*7: Displays the current consumption when writing is always conducted at f_{cyc} .

The current consumption during access is effectively proportional to the access frequency (f_{cyc}).

*8: Specify the minimum pulse width of the \overline{RES} signal. For resetting, input a pulse width of t_{RW} or wider.

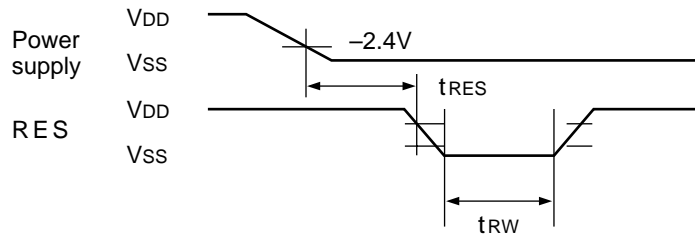

*9: The boosting circuit boosts using V_{SS2} as the source voltage. Be sure for the V_{SS2} input voltage not to exceed the maximum operating voltage of V_{OUT} .

*10: The oscillation circuit frequency for driving the internal circuit (f_{osc}) and the boosting clock (f_{BST}) depend on the machine type.

The relationship between oscillating frequency f_{osc} , boosting clock f_{BST} and frame frequency f_{FR} is as follows:

$$f_{osc} = (\text{number of digits}) \times (1/\text{duty}) \times f_{FR}$$

$$f_{BST} = (1/2) \times (1/\text{number of digits}) \times f_{osc}$$

*11: When using an external clock and not using the built-in oscillation circuit for operation, input the following waveform.

$$\text{Duty} = (t_h / t_{osc}) \times 100 = 20 \text{ to } 30 \%$$

$$f_{osc} = 1 / t_{osc}$$

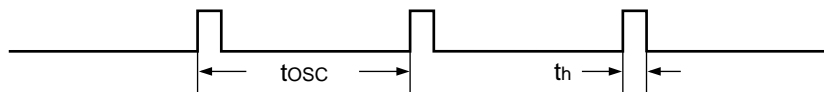

NOTICE:

No part of this material may be reproduced or duplicated in any form or by any means without the written permission of Seiko Epson. Seiko Epson reserves the right to make changes to this material without notice. Seiko Epson does not assume any liability of any kind arising out of any inaccuracies contained in this material or due to its application or use in any product or circuit and, further, there is no representation that this material is applicable to products requiring high level reliability, such as, medical products. Moreover, no license to any intellectual property rights is granted by implication or otherwise, and there is no representation or warranty that anything made in accordance with this material will be free from any patent or copyright infringement of a third party. This material or portions thereof may contain technology or the subject relating to strategic products under the control of the Foreign Exchange and Foreign Trade Law of Japan and may require an export license from the Ministry of International Trade and Industry or other approval from another government agency.

© Seiko Epson Corporation 2000 All right reserved.

All other product names mentioned herein are trademarks and/or registered trademarks of their respective companies.

SEIKO EPSON CORPORATION**ELECTRONIC DEVICES MARKETING DIVISION****IC Marketing & Engineering Group****ED International Marketing Department I (Europe, U.S.A)**

421-8 Hino, Hino-shi, Tokyo 191-8501, JAPAN
Phone: 042-587-5812 FAX: 042-587-5564

ED International Marketing Department II (ASIA)

421-8 Hino, Hino-shi, Tokyo 191-8501, JAPAN
Phone: 042-587-5814 FAX: 042-587-5110

■ Electronic devices information on the Epson WWW server.

<http://www.epson.co.jp/device/>

