HD74LVC32

Quad. 2-input OR Gates

HITACHI

ADE-205-065B(Z)

Rev.2

September 1995

Description

The HD74LVC32 has four 2-input OR gates in a 14 pin package. Low voltage and high speed operation is suitable at the battery drive product (note type personal computer) and low power consumption extends the life of a battery for long time operation.

Features

- $V_{cc} = 2.0 \text{ V to } 5.5 \text{ V}$
- All inputs $V_{IH} (\text{Max.}) = 5.5 \text{ V} (@V_{cc} = 0 \text{ V to } 5.5 \text{ V})$
- Typical V_{ol} ground bounce $< 0.8 \text{ V} (@V_{cc} = 3.3 \text{ V}, T_a = 25^\circ\text{C})$
- Typical V_{OH} undershoot $> 2.0 \text{ V} (@V_{cc} = 3.3 \text{ V}, T_a = 25^\circ\text{C})$
- High output current $\pm 24 \text{ mA} (@V_{cc} = 3.0 \text{ V to } 5.5 \text{ V})$

Function Table

Inputs		Output Y
A	B	
L	L	L
H	L	H
L	H	H
H	H	H

H : High level

L : Low level

HD74LVC32

Pin Arrangement

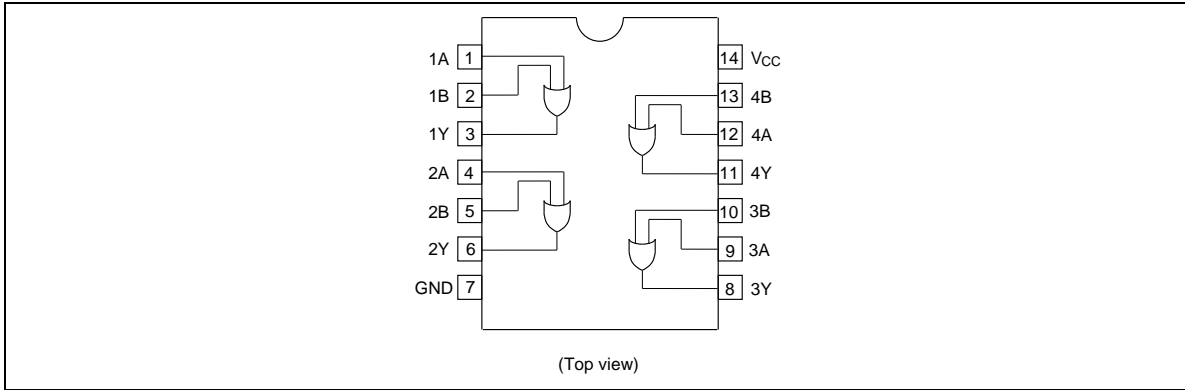

Absolute Maximum Ratings

Item	Symbol	Ratings	Unit	Conditions
Supply voltage range	V_{CC}	-0.5 to 6.0	V	
Input diode current	I_{IK}	-50	mA	$V_I = -0.5\text{ V}$
Input voltage	V_I	-0.5 to 6.0	V	
Output diode current	I_{OK}	-50	mA	$V_O = -0.5\text{ V}$
		50	mA	$V_O = V_{CC}+0.5\text{ V}$
Output voltage	V_O	-0.5 to $V_{CC}+0.5$	V	
Output current	I_O	± 50	mA	
V_{CC} , GND current / pin	I_{CC} or I_{GND}	100	mA	
Storage temperature	Tstg	-65 to +150	°C	

Note: The absolute maximum ratings are values which must not individually be exceeded, and furthermore, no two of which may be realized at the same time.

Recommended Operating Conditions

Item	Symbol	Ratings	Unit	Conditions
Supply voltage	V_{CC}	1.5 to 5.5	V	Data retention
		2.0 to 5.5	V	At operation
Input / Output voltage	V_I	0 to 5.5	V	A, B
	V_O	0 to V_{CC}	V	Y
Operating temperature	T_a	-40 to 85	°C	
Output current	I_{OH}	-12	mA	$V_{CC} = 2.7\text{ V}$
		-24 ²	mA	$V_{CC} = 3.0\text{ V to }5.5\text{ V}$
	I_{OL}	12	mA	$V_{CC} = 2.7\text{ V}$
		24 ²	mA	$V_{CC} = 3.0\text{ V to }5.5\text{ V}$
Input rise / fall time ¹	t_r, t_f	10	ns/V	

Notes: 1. This item guarantees maximum limit when one input switches.
 Waveform : Refer to test circuit of switching characteristics.
 2. duty cycle ≤ 50%

Electrical Characteristics

Item	Symbol	V_{CC} (V)	$T_a = -40\text{ to }85^\circ\text{C}$		Unit	Test Conditions
			Min	Max		
Input voltage	V_{IH}	2.7 to 3.6	2.0	—	V	
		4.5 to 5.5	$V_{CC} \times 0.7$	—	V	
	V_{IL}	2.7 to 3.6	—	0.8	V	
		4.5 to 5.5	—	$V_{CC} \times 0.3$	V	
Output voltage	V_{OH}	2.7 to 5.5	$V_{CC} - 0.2$	—	V	$I_{OH} = -100\ \mu\text{A}$
		2.7	2.2	—	V	$I_{OH} = -12\ \text{mA}$
		3.0	2.4	—	V	$I_{OH} = -12\ \text{mA}$
		3.0	2.0	—	V	$I_{OH} = -24\ \text{mA}$
		4.5	3.8	—	V	$I_{OH} = -24\ \text{mA}$
	V_{OL}	2.7 to 5.5	—	0.2	V	$I_{OL} = 100\ \mu\text{A}$
		2.7	—	0.4	V	$I_{OL} = 12\ \text{mA}$
		3.0	—	0.55	V	$I_{OL} = 24\ \text{mA}$
		4.5	—	0.55	V	$I_{OL} = 24\ \text{mA}$
		Input current	I_{IN}	0 to 5.5	—	±5.0
Quiescent supply current	I_{CC}	5.5	—	20	μA	$V_{IN} = V_{CC}\text{ or GND}$
	ΔI_{CC}	3.0 to 3.6	—	500	μA	$V_{IN} = \text{one input at } (V_{CC} - 0.6)\text{V, other inputs at } V_{CC}\text{ or GND}$

HD74LVC32

Switching Characteristics

Item	Symbol	V_{CC} (V)	$T_a = -40 \text{ to } 85^\circ\text{C}$			Unit	From (Input)	To (Output)
			Min	Typ	Max			
Propagation delay time	t_{PLH}	2.7	—	4.5	7.0	ns	A or B	Y
	t_{PHL}	3.3 ± 0.3	1.5	3.5	6.0	ns		
		5.0 ± 0.5	—	3.0	5.0	ns		
Input capacitance	C_{IN}	2.7	—	3.0	—	pF		
Output capacitance	C_O	2.7	—	15.0	—	pF		

Test Circuit

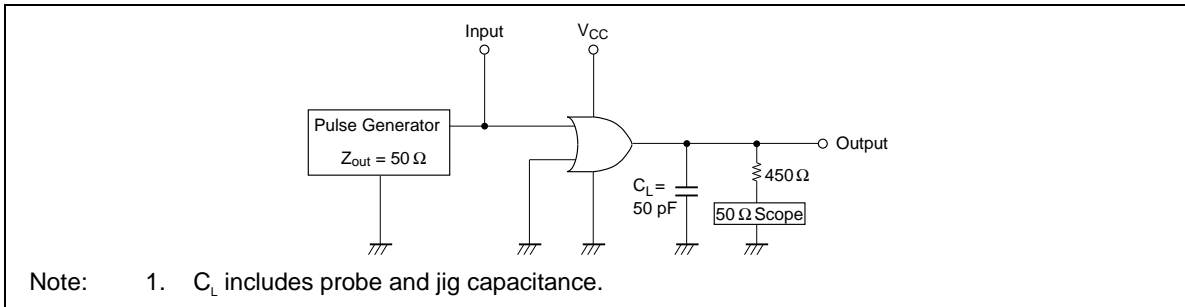

Waveforms

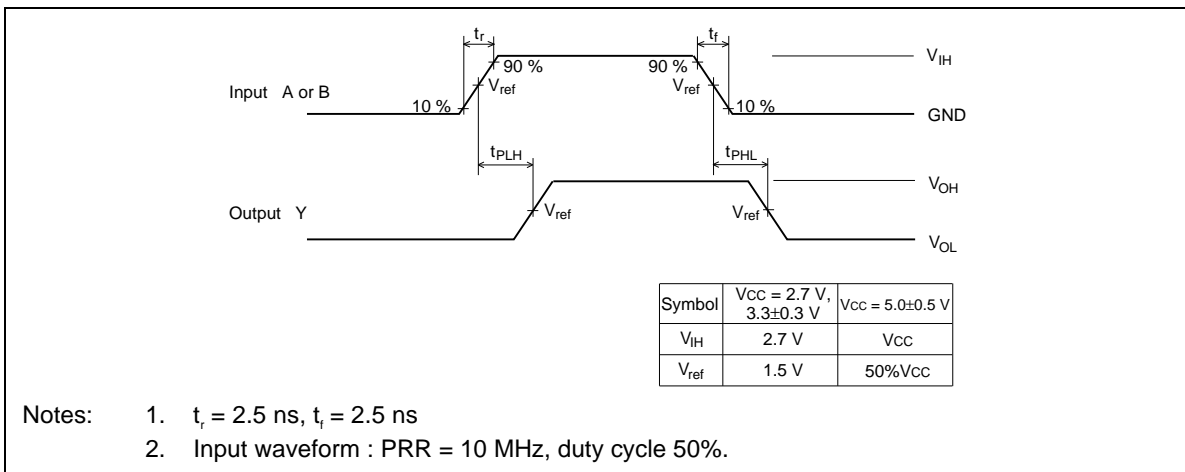

Notice

When using this document, keep the following in mind:

1. This document may, wholly or partially, be subject to change without notice.
2. All rights are reserved: No one is permitted to reproduce or duplicate, in any form, the whole or part of this document without Hitachi's permission.
3. Hitachi will not be held responsible for any damage to the user that may result from accidents or any other reasons during operation of the user's unit according to this document.
4. Circuitry and other examples described herein are meant merely to indicate the characteristics and performance of Hitachi's semiconductor products. Hitachi assumes no responsibility for any intellectual property claims or other problems that may result from applications based on the examples described herein.
5. No license is granted by implication or otherwise under any patents or other rights of any third party or Hitachi, Ltd.
6. **MEDICAL APPLICATIONS:** Hitachi's products are not authorized for use in **MEDICAL APPLICATIONS** without the written consent of the appropriate officer of Hitachi's sales company. Such use includes, but is not limited to, use in life support systems. Buyers of Hitachi's products are requested to notify the relevant Hitachi sales offices when planning to use the products in **MEDICAL APPLICATIONS**.