

# HA16817ANT/HA16817AMP

## SLIC IC for PBX Applications

Bipolar linear process monolithic SLIC IC for PBX applications

### Features

- Basic Functions: Internal battery feed control (B), loop monitor (S) and 2 W-4 W conversion
- Constant Current Feed: -48 V supply voltage
- Internal Darlington power transistor
- Ring trip detection
- Current shutdown function
- Two internal relay drivers

### Functions

#### Basic Functions

##### Current Feed Control

For PBX use, the Hitachi SLIC adapts the constant feed current method for short distance line use. Therefore, low power dissipation is realized by keeping the loop current Typical value at 27 mA when loop resistance  $R_L = 50 \Omega$ . In addition, integration of power transistors for battery feed saves mounting space on line cards.

Noise suppression circuitry insures impedance balance by improving the relative precision of the  $39 \Omega$  potential detect emitter resistor (equipped on both VBB and GND sides).

##### Loop Detection

The SLIC detects subscribers' hook status (on/off) and outputs it to the SCN pin.

##### DC loop detection:

Detects DC loop status (open or closed) using a potential detection emitter connected to a current feed circuit and outputs it to the SCN pin through a comparator.

##### Ring Trip Detection:

See Additional Functions

##### 2 w-4 w Conversion

The SLIC provides 2-wire balanced to 4-wire single ended conversions preventing the 4-wire input signal from returning to the 4-wire output by using external  $C_x$ ,  $Z_x$ , ZBN and internal opamp circuits.

### Additional Functions

#### Ring Trip Detection

With an externally connected CR filter, the Hitachi SLIC can detect the off-hook status of a called subscriber while ring relay is sending a ringing signal. When the subscriber goes off hook, a DC current superimposed on the ringing signal flows through the

## Pin Arrangement

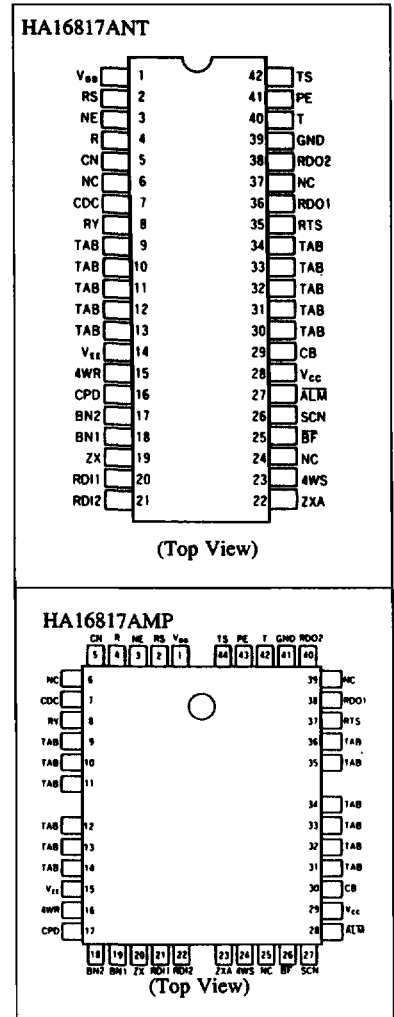

# HA16817ANT/HA16817AMP

## Current Shut-Off Function

To protect PBX systems from the following problems, current feed is stopped by a command issued from the system controller to the BF pin.

- Subscriber loop line faults
- Emergency overload

## Relay Drivers

The Hitachi SLIC has two internal relay drivers which drive the relay coil directly when an enable signal is sent to the RDI1 or RDI2 pin.

## Block Diagram

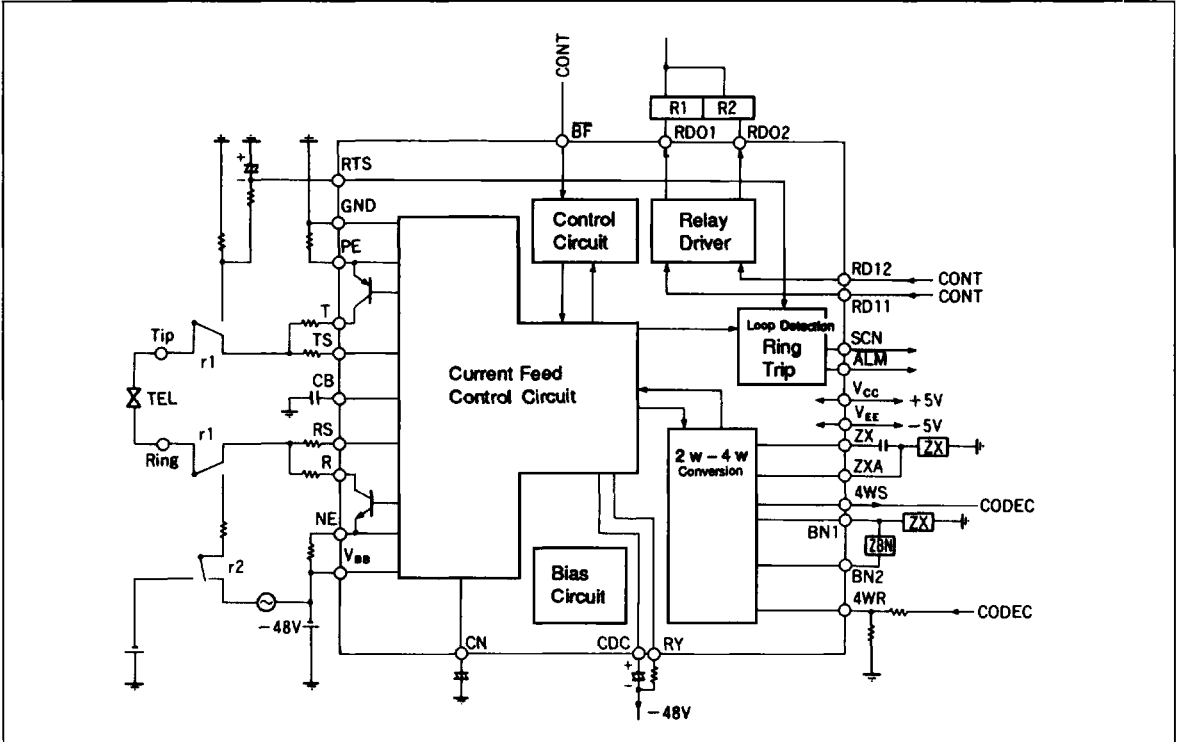

## Pin Description

No. NT	MP	Name	Functional Description
1	1	V <sub>BB</sub>	-48 V source input
2	2	RS	Ring-side potential detection input connected to the subscriber line through the detection resistor
3	3	NE	Ring-side NPN Darlington transistors' emitter potential detection input connected to V <sub>BB</sub> (-48 V) through the emitter resistor
4	4	R	Ring-side current feed output (sink) connected to the subscriber line through the protection resistor
5	5	CN	Connected to ground through the noise filtering capacitor for power supply
6	6	NC	No connection Must not be connected to any other pin or printed circuit
7	7	CDC	Low-pass filter capacitor connection pin for DC feedback
8	8	RY	Connected to -48 voltage source through the resistor to make a precise differential feedback loop
9-10	9-14	TAB	Heatsink pins, connected to the heatsink area fabricated on the printed board. They must not be connected to any other pin or printed circuit.
14	15	V <sub>EE</sub>	-5 voltage source input
15	16	4WR	4-wire receive input which is connected to CODEC analog output through bleeder resistor for gain adjustment
16	17	CPD	Ground/battery short protection capacitor pin. Ground through capacitor.
17	18	BN2	Received signal output pin connected to BN1 through balancing impedance Z <sub>BN</sub>
18	19	BN1	Analog input of differential amp. For transhybrid rejection, it's connected to the ground through termination impedance Z <sub>x</sub> , and to BN2 through impedance Z <sub>BN</sub> .
19	20	ZX	DC cut capacitor and termination impedance Z <sub>x</sub> run between this terminal and ground
20	21	RD11	TTL-level digital input for relay enable signal from the system controller
21	22	RD12	TTL-level digital input for relay enable signal from the system controller
22	23	ZXA	Analog input of differential amp. For transmission, connected between termination impedance Z <sub>x</sub> and DC cut capacitor.
23	24	4WS	4-wire transmission output connected to CODEC
24	25	NC	No connection Must not be connected to any other pin or printed circuit
25	26	BF	TTL-level digital input for current shut-off command from the system controller. The current shut-off is enabled when input pin voltage is high.
26	27	SCN	TTL-level compatible digital output which is the common output of loop monitor and ring trip detection signals
27	28	ALM	Ground detection output pin
28	29	V <sub>CC</sub>	+5 voltage source input
29	30	CB	Connected to the ground through the phase compensation capacitor for balance amp
30-34	31-36	TAB	Heatsink pins, connected to the heatsink area fabricated on the printed board. They must not be connected to any other pin or printed circuit.
35	37	RTS	CR for ring trip detection is connected to this terminal.
36	38	RDO1	Analog output of relay driver connected to -48 voltage source through a relay coil
37	39	NC	No connection. Must not be connected to any other pin or printed circuit.
38	40	RDO2	Analog output of relay driver connected to -48 voltage source through a relay coil
39	41	GND	Ground pin
40	42	T	Tip-side current feed output (sink) connected to the subscriber line through the protection resistor
41	43	PE	Tip-side PNP Darlington transistors' emitter potential detection input connected to V <sub>BB</sub> (-48 V) through the emitter resistor
42	44	TS	Ring-side potential detection input connected to the subscriber line through the detection resistor

# HA16817ANT/HA16817AMP

## Absolute Maximum Ratings (Ta = 25°C)

Item	Symbol	Rating	Unit	Notes
Supply Voltage	V <sub>BB</sub>	-60	V	
	V <sub>CC</sub>	7	V	
	V <sub>EE</sub>	-7	V	
Power Dissipation	P <sub>r</sub>	1.3	W	(Note 1)
Operating Temperature	T <sub>opr</sub>	0 to +70	°C	
Storage Temperature	T <sub>stg</sub>	-55 to +125	°C	
Junction Temperature	T <sub>jmax</sub>	150	°C	
Input Voltage	V <sub>in1</sub>	-0.3 to V <sub>CC</sub> +0.3	V	Digital input pin (Note 2)
	V <sub>in2</sub>	-5.0 to +0.3	V	RTS pin
Input Current	I <sub>rs</sub>	±117	mA	R <sub>s</sub> pin, t ≤ 2 ms
	I <sub>ts</sub>	±117	mA	T <sub>s</sub> pin, t ≤ 2 ms
Relay Driver Output Source Current	I <sub>RDO</sub>	-30	mA	RDO1, RDO2 pins

- Notes 1: See derating curve  
 2: Indicates each BF, LPB, RDI1 AND RDI2

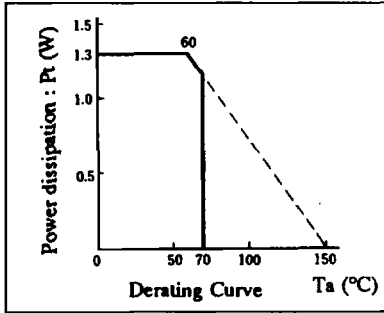

**Recommended Operating Conditions**

Item		Symbol	Condition	Min	Typ	Max	Unit
Supply Voltage		V <sub>BB</sub>		-53	-48	-43	V
		V <sub>CC</sub>		4.75	5	5.25	V
		V <sub>EE</sub>		-5.25	-5	-4.75	V
Loop Resistance		R <sub>L</sub>	Line resistance + Terminal resistance	50	—	1200	Ω
Signal Input Level	2W	V <sub>I2W</sub>		—	—	3.5	dBm
	4W	V <sub>I4W</sub>		—	—	1.5	dBm
ZX condition	Load impedance	R <sub>ZX1</sub>	Connectable load impedance	10	—	—	kΩ
ZXA condition	Signal source impedance	R <sub>ZR</sub>	Connectable signal source impedance	—	—	200	kΩ
BN1 condition	Signal source impedance	R <sub>BN1</sub>	Connectable signal source impedance	—	—	50	kΩ
BN2 condition	Load impedance	R <sub>BN2</sub>	Connectable load impedance	10	—	—	kΩ

# HA16817ANT/HA16817AMP

## Electrical Characteristics

DC Characteristics ( $V_{BB} = -48\text{ V}$ ,  $V_{CC} = 5\text{ V}$ ,  $V_{EE} = -5\text{ V}$ ,  $T_a = 25^\circ\text{C}$ )

Item		Symbol	Test Condition	Min	Typ	Max	Unit
Power Supply	On hook	$I_{BB}$	$R_L = \infty$	-4.0	-1.3	—	mA
		$I_{CC}$		—	6.6	12.0	mA
		$I_{EE}$		-5.0	-2.5	—	mA
	Off hook	$I_{BBL}$	$R_L = 50\ \Omega$	-9.0	-4.8	—	mA
		$I_{CCL}$		—	8.1	14.0	mA
		$I_{EEL}$		-5.0	-2.5	—	mA
Power Dissipation	On hook	$P_{DC}$	$R_L = \infty$	—	—	270	mW
	Off hook	$P_{DCL}$	$R_L = 200\ \Omega$	—	—	1300	mW
Direct Current Feed		$I_{LO}$	$R_L = 50\ \Omega$	24	27	31	mA
		$I_{L300}$	$R_L = 600\ \Omega$	24	27	31	mA
		$I_{L600}$	$R_L = 1200\ \Omega$	20	—	—	mA
Loop Detection	Off hook	$I_{LTH1}$		11	—	16	mA
Current	On hook	$I_{LTH2}$		6	—	11	mA
Relay Driver Output Voltage		$RDV_{OH}$	$I_{OH} = -30\text{ mA}$	-2.0	—	—	V
Ring Trip Comparator Threshold Voltage		$RTSV_{TH}$		-0.97	-0.85	-0.74	V
Input Clamp Diode		$V_{FAP}$	$V_{BB} = 10\text{ V}$	0.3	—	3	V
		$V_{FAN}$	$I_F = 117\text{ mA}$	0.3	—	3	V
		$V_{FBP}$		0.3	—	3	V
		$V_{FBN}$		0.3	—	3	V
Ground Short Protection	On	$R_{GF1}$	$V_{BB} = -43\text{ V}$	250	—	—	$\Omega$
	Off	$R_{GR3}$	$V_{BB} = -48\text{ V}$	—	—	20	k $\Omega$
Battery Short Protection	On	$R_{BF1}$	$V_{BB} = -43\text{ V}$	250	—	—	$\Omega$
	Off	$R_{BR3}$	$V_{BB} = -48\text{ V}$	—	—	20	k $\Omega$
Digital Input/Output	$\overline{BF}$	$BFV_{IH}$	—	2.0	—	—	V
		$BFV_{IL}$	—	—	—	0.8	V
		$BFI_{IH}$	$V_{IH} = 2.0\text{ V}$	-5	0	5	$\mu\text{A}$
		$BFI_{IL}$	$V_{IL} = 0.8\text{ V}$	-10	1	5	$\mu\text{A}$
	RDI1	$RD1V_{IH}$	—	2.0	—	—	V
		$RD1V_{IL}$	—	—	—	0.8	V
		$RD1I_{IH}$	$V_{IH} = 2.0\text{ V}$	65	100	170	$\mu\text{A}$
		$RD1I_{IL}$	$V_{IL} = 0.8\text{ V}$	14	40	70	$\mu\text{A}$
	RDI2	$RD2V_{IH}$	—	2.0	—	—	V
		$RD2V_{IL}$	—	—	—	0.8	V
		$RD2I_{IH}$	$V_{IH} = 2.0\text{ V}$	65	100	170	$\mu\text{A}$
		$RD2I_{IL}$	$V_{IL} = 0.8\text{ V}$	14	40	70	$\mu\text{A}$
	SCN	$SCNV_{OL}$	$V_{CC} = 5.25\text{ V}$ $I_{OL} = 1.6\text{ mA}$	—	—	0.4	V
		$SCNV_{OH}$	$V_{CC} = 4.75\text{ V}$ $I_{OH} = -0.4\text{ mA}$	2.4	—	—	V
	$\overline{ALM}$	$ALMV_{OL}$	$V_{CC} = 5.25\text{ V}$ $I_{OL} = 1.6\text{ mA}$	—	—	0.4	V
		$ALMV_{OH}$	$V_{CC} = 4.75\text{ V}$ $I_{OH} = -0.4\text{ mA}$	2.4	—	—	V

# HA16817ANT/HA16817AMP

## AC Characteristics ( $V_{BB} = -48\text{ V}$ , $V_{CC} = 5\text{ V}$ , $V_{EE} = -5\text{ V}$ , $T_a = 25^\circ\text{C}$ )

Item	Symbol	Test Condition	Input Level ( $V_{rms}$ )	Min	Typ	Max	Unit	
Transmission Gain	2 w→4 w	G241	f = 1 kHz	1.16	5.70	6.00	6.30	dB
	4 w→2 w	G421	$R_L = 200\ \Omega$	0.921	1.7	2.0	2.3	dB
Attenuation Distortion	2 w→4 w	GF24	f = 3.4 kHz	1.16	-0.1	—	0.1	dB
	4 w→2 w	GF42	f = 1 kHz $R_L = 200\ \Omega$	0.921	-0.1	—	0.1	dB
Idle Channel Noise		NI2	$R_L = 200\ \Omega$	—	—	—	-81.1	dBmop
		NI4		—	—	—	-81.1	dBmop
S/N	2 w→4 w	SN24	f = 1 kHz	1.16	53	—	—	dB
	4 w→2 w	SN42	$R_L = 1.2\ \Omega$	0.921	53	—	—	dB
Impedance Balance		LB2W	f = 3.4 kHz 1 kHz $R_L = 1.2\ \text{k}\Omega$	0.775	40	—	—	dB
Return Loss		LM1	f = 0.3 kHz $R_L = 200\ \Omega$	1.16	20	—	—	dB
Balance Return Loss		LR	f = 3.4 kHz $R_L = 1.2\ \text{k}\Omega$	0.921	23	—	—	dB
Idle Channel Noise on Alternating Current Induction		NI2AC	$R_L = 1.2\ \text{k}\Omega$ f = 60 Hz IAC = 6.4 mArms	—	—	—	-67	dBmop
PSRR	$V_{BB} \rightarrow 2\text{ w}$	LB2	f = 3.4 kHz	24.5 mVrms	20	—	—	dB
	$V_{CC} \rightarrow 2\text{ w}$	LC2	$R_L = 1.2\ \text{k}\Omega$	24.5 mVrms	20	—	—	dB
	$V_{EE} \rightarrow 2\text{ w}$	LE2		24.5 mVrms	20	—	—	dB

## Digital Input/Output Logic

### SCN, ALM Output Logic Truth Table

$\overline{\text{BF}}$	RL	Status		SCN	$\overline{\text{ALM}}$
		Ground <sup>(Note 1)</sup>	Ground Protection <sup>(Note 2)</sup>		
L	On hook	T	T	H	L
		F	F	H	H
		F	F	L	H
	Off hook	T	T	H	L
		F	F	H	H
		F	F	H	H
H	On hook	T	T	H	L
		F	F	L	H
		F	F	L	H
	Off hook	T	T	H	L
		F	F	L	H
		F	F	L	H

Notes 1 T: Ground/battery short F: No ground/battery short  
2 T: Ground protection F: No ground protection

---

# HA16817ANT/HA16817AMP

---

## Relay Driver Truth Table

Input		Output	
RDI1	RDI2	RDO1	RDO2
H	—	H(ON)	—
L	—	L(OFF)	—
—	H	—	H(ON)
—	L	—	L(OFF)

## BF Truth Table

BF	Battery Feed
H	Battery feed shut down
L	Battery feed

## Application Circuit Example

HA16817ANT (Input impedance: 600Ω)

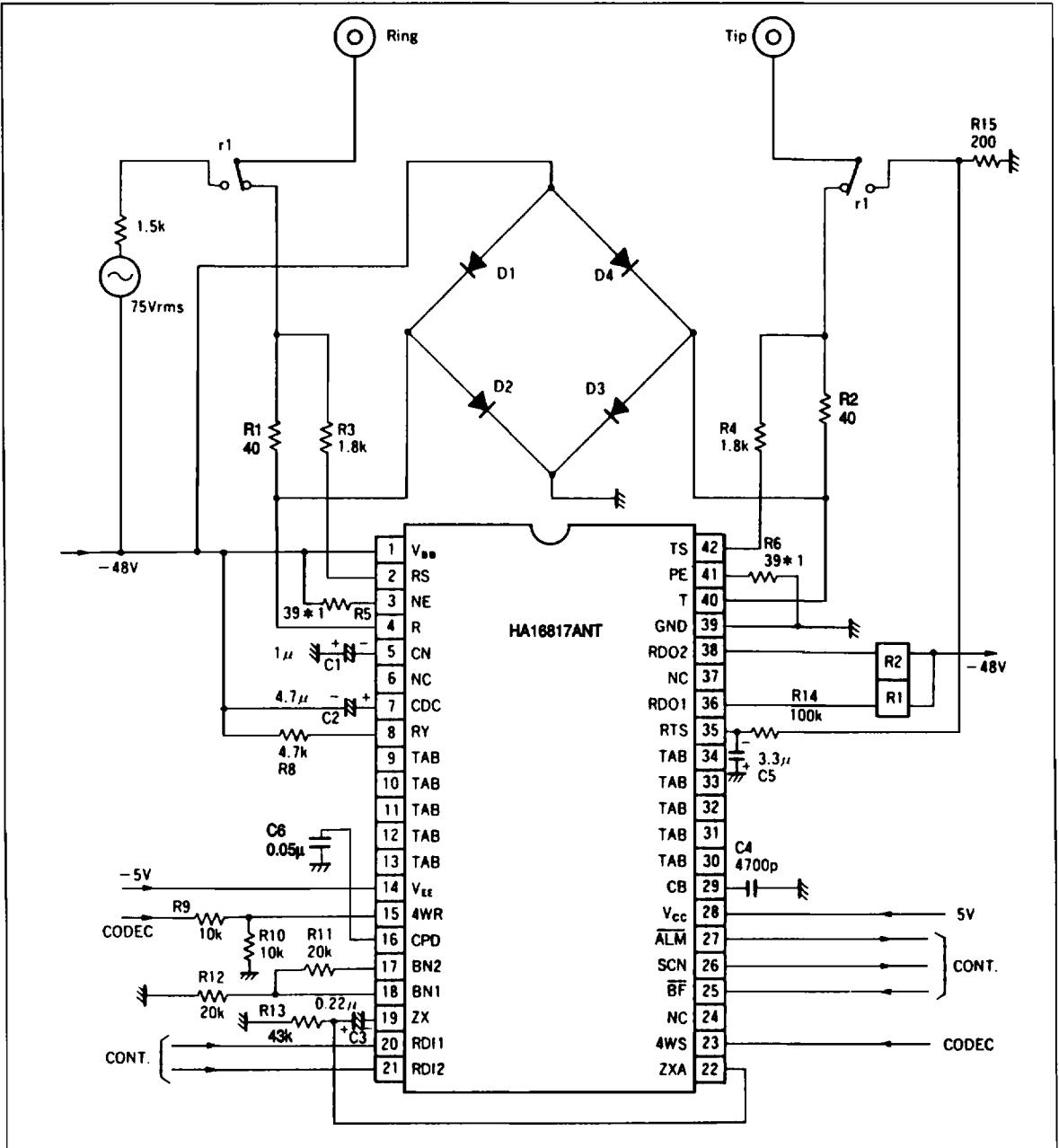

Note: Relative precision of these registers should be within  $\pm 0.1\%$  Figure 1

Figure 1

# HA16817ANT/HA16817AMP

HA16817AMP (Input impedance: 600Ω)

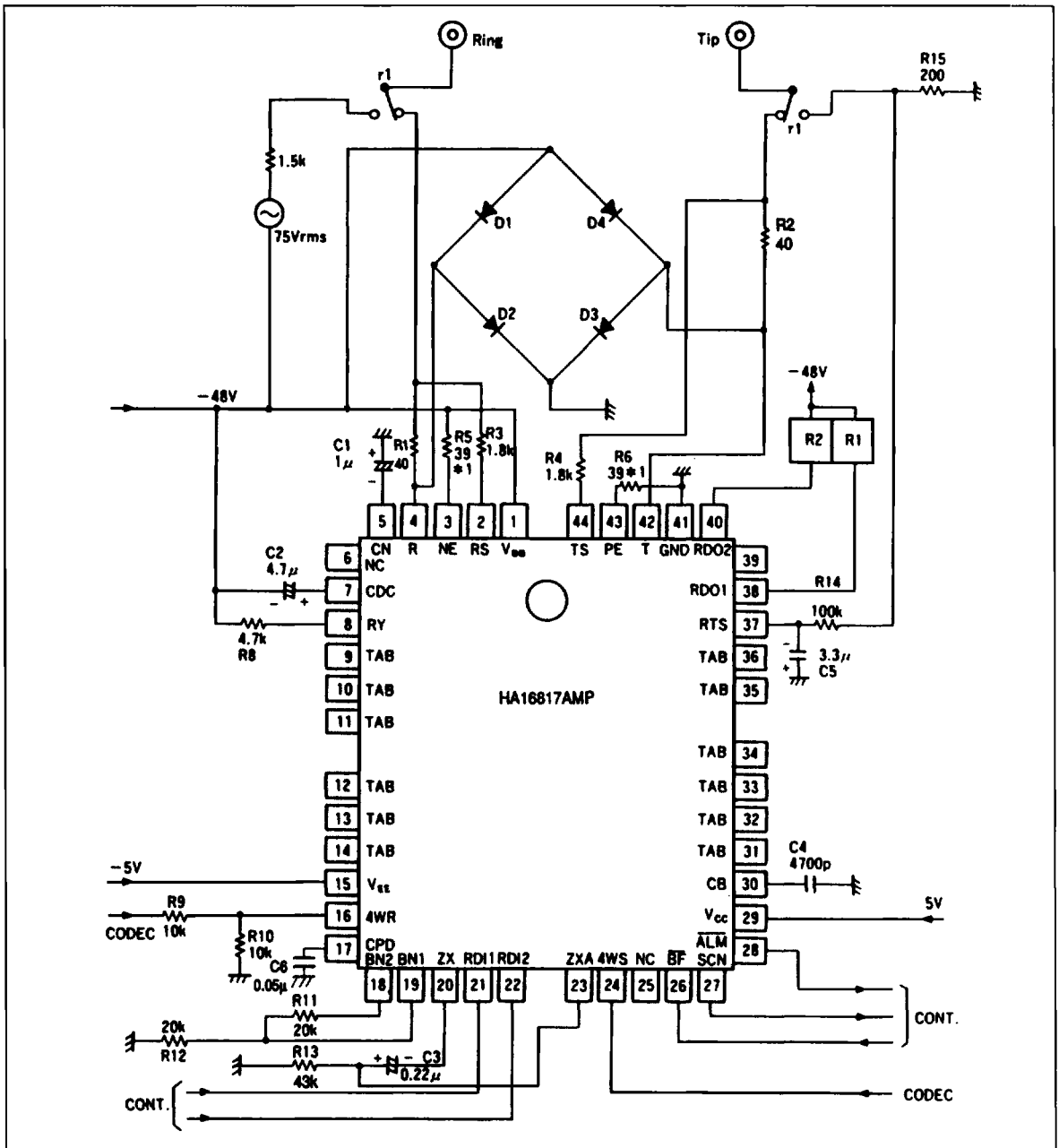

Note: Relative precision of these registers should be within  $\pm 0.1\%$

External Connected Components Specification Example

Table 1

Name	Spec	Accuracy	Unit	Power dissipation	Remark	Note
R1	40	5%	Ω	500 mW	For R pin lightning surge protection	1
R2	40	5%	Ω	500 mW	For T pin lightning surge protection	↓
R3	1.8	1%	kΩ	5 mW	For RS pin lightning surge protection	2
R4	1.8	1%	kΩ	5 mW	For TS pin lightning surge protection	↓
R5	39	0.1%	Ω	140 mW		3
R6	39	0.1%	Ω	140 mW		↓
R7	1.5	3%	kΩ	2.9 W	The current during ring-tripping should be considered.	4
R8	4.7	1%	kΩ	0.42 mW		5
R9	10		kΩ	0.08 mW		↓
R10	10		kΩ	0.08 mW		↓
R11	20		kΩ	0.01 mW		↓
R12	20		kΩ	0.01 mW		↓
R13	43		kΩ	0.02 mW		↓
R14	100	5%	kΩ	5.3 mW		
R15	200	3%	Ω	390 mW	The current during ring-tripping should be considered.	4
C1	1	20%	μF	—	(high drive voltage) 60	
C2	4.7	20%	μF	—	15 V	
C3	0.22	10%	μF	—	15 V	6
C4	4700	10%	pF	—	60 V	
C5	3.3	10%	μF	—	60 V	
D1	IF <sub>peak</sub> ≥1 A	—	A		For R and T pin lightning surge protections	1
D2	↓	—	A			
D3	↓	—	A			
D4	↓	—	A			

Note

1. R1, R2 are protected in HA16817A from lightning surge.

- 1) The resistance should be able to withstand the lightning surge current of 200 V/R1 and 200 V/R2 during lightning surge time ≅ 2 ms.
- 2) D1-D4 also should be able to withstand the lightning surge current peak.

2. The resistance should be able to withstand lightning surge current of 117 mA during surge time ≅ 2 ms.

3. When high-speed, large amplitude (more than around 7 Vo-p) impulse noise is input to the tip and

ring pins, peak current 150 mA (max), flows through the resistor.

4. Delay time for relay switching must be considered when ring tripping.  
Trip delay depends on the time constant of the external filter. In this case, the estimated time is around 300 ms (max).

$$\text{Current for ring trip} = \frac{(V_{BB} + V_{Ringing})}{R7 + R15}$$

	R7	R15
Power dissipation when tripping	8 W	1.1 W

5. These resistances are inserted to the pass which is only for audio signals. Therefore, the level of the

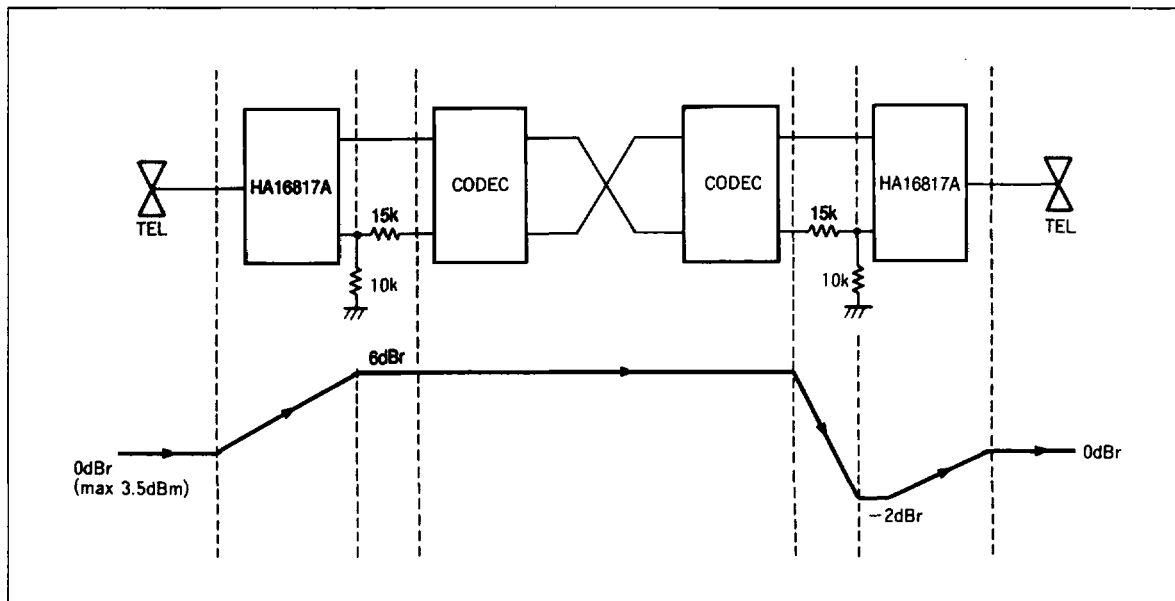

Figure 2

audio signals should be considered in power dissipation calculations. The power dissipation in the above table is calculated according to the assumed level diagram shown below.

The 4 WR to BN 2 gain is 0dB (BN 1 is a buffer amp input pin).

- These values have a great effect on return loss and balance return loss. Therefore, capacitors whose temperature coefficients are high, such as layer-built ceramic capacitors, are not adequate for this circuit. At the ZX pin, DC0 volts appears when the hook status is "On" and -20 volts appears when the status is "Off".

### Direct Current Feed

Direct current feed characteristics separate into a characteristic in a fixed current feed area and a characteristic in a fixed resistance feed area. In the fixed current feed area, the current is fed constantly by any supply voltage ( $V_{BB}$ ) and line resistance. In the fixed resistance area, on the other hand, the current feed depends on the values of power supply and line resistance. The values can be obtained with the following formula.

$$I_L = |V_{BB}| / (R_L + R_f) \text{ (A)}$$

$R_f$  means feed resistance and is  $800 \Omega \pm 10\%$ .  
( $2 \times 200 \Omega$ )

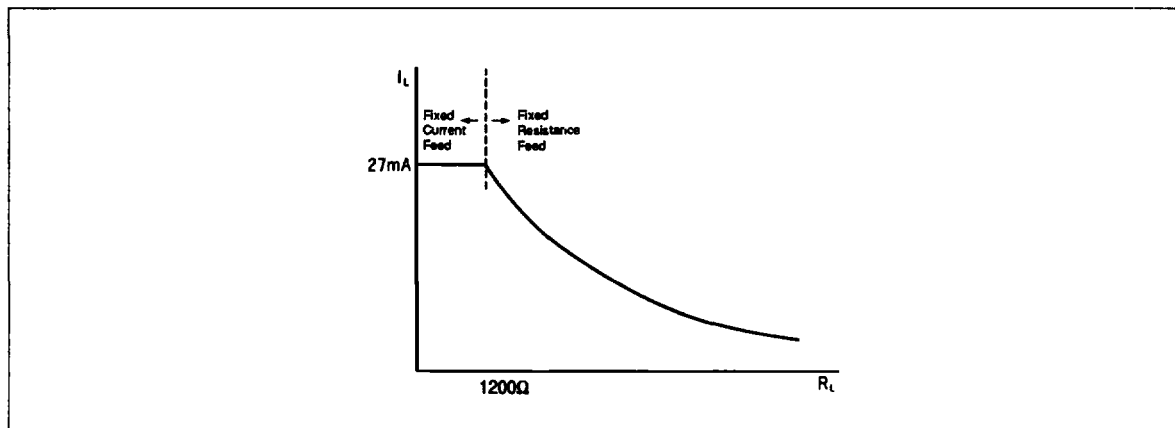

Figure 3

## Termination Impedance Setting

By selecting an adequate external impedance, a termination impedance can be set at the required value. When the impedance of the Zx pin to GND is denoted Z<sub>x</sub>, termination impedance Z<sub>T</sub> is obtained with the following formula.

$$Z_T = Z_x / K \quad K = 75.8$$

Be sure to insert C<sub>x</sub>, since it is also a coupling capacitor between Z<sub>x</sub> and Z<sub>XA</sub> and cannot be omitted. When using C<sub>x</sub> only for DC out, the capacitance should

be selected so that the impedance in the speech band is much lower than the termination impedance. Normally, around 0.1 μF is adequate. At the ZX pin, DC0 volts appears when the hook status is "On" and -8 volts appears when the status is "Off". Verify polarity when using electrolytic capacitors and the like.

Table 2 shows the specifications of termination impedance and external circuit constants for three countries excerpted from the ITU-T Recommendation.

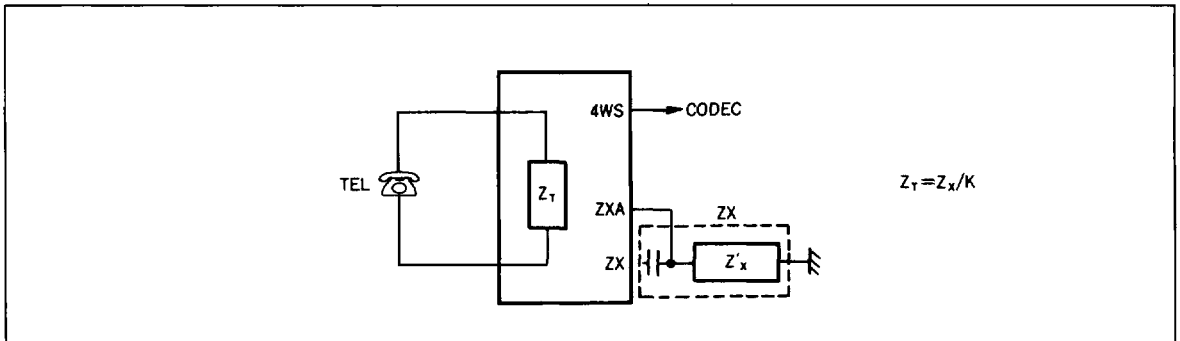

Figure 4

Table 2 Termination Impedance and External Circuit

No.	1	2
Z <sub>T</sub>		
Z <sub>x</sub> of HA16817A		
Z <sub>x</sub> of HA16817		

$Z_T = 600\Omega + 1/(j\omega \times 1\mu F)$   
 $Z_x = K \times Z_T = K \times 600\Omega + 1/(j\omega \times 1\mu F / K)$

# HA16817ANT/HA16817AMP

## Balancing Network Setting

The 4 W to 4 W transfer function is

$$G_{44} = 4 [Z_{BN} / (Z_{BN} + Z_{XO}) - Z_T / (Z_L + Z_T)].$$

Therefore, when  $Z_L = Z_T$ , the formula becomes

$$G_{44} = 4 [Z_{BN} / (Z_{BN} + Z_{XO}) - 1/2].$$

$G_{44} = 0$  can be obtained when  $Z_{BN} = Z_{XO}$ .

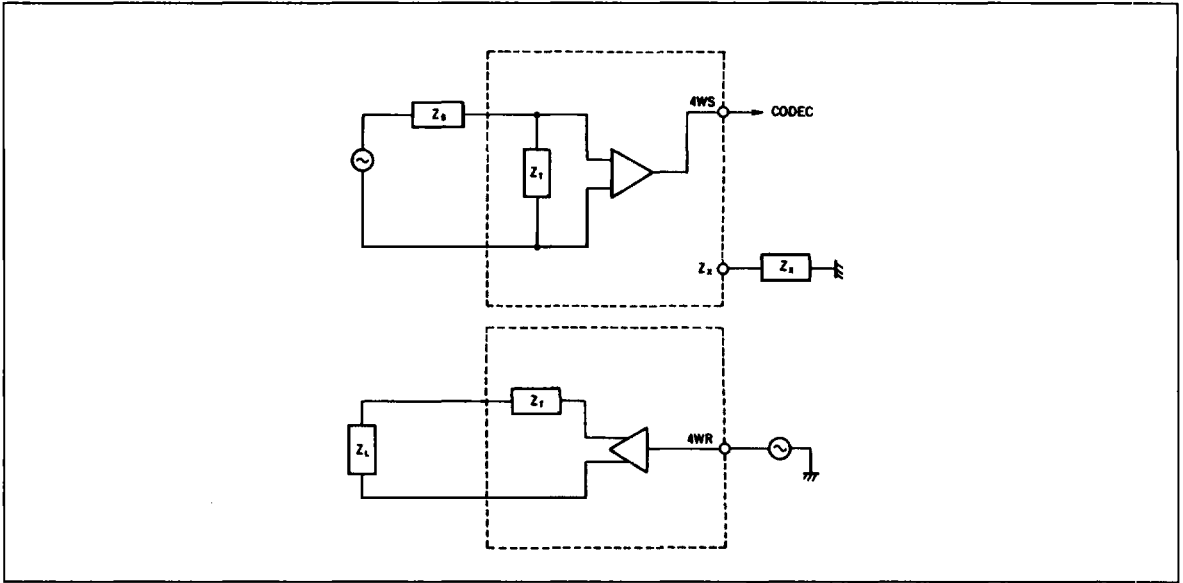

## Level Diagram

The 2 W-4 W transmission gain formula is

$$G_{24} = 20 \log |2 Z_T / (Z_s + Z_T)| + 3.85 (\pm 0.3) \text{ (dB)}$$

The 4 W-2 W transmission gain formula is

$$G_{42} = 20 \log |2 Z_T / (Z_s + Z_T)| + 2.0 (\pm 0.3) \text{ (dB)}$$

Therefore, when  $Z_T = Z_L = Z_s$ , the following formulas are obtained.

HA16817A		
G <sub>24</sub>	6.00 ±0.3	dB
G <sub>42</sub>	2.00 ±0.3	dB

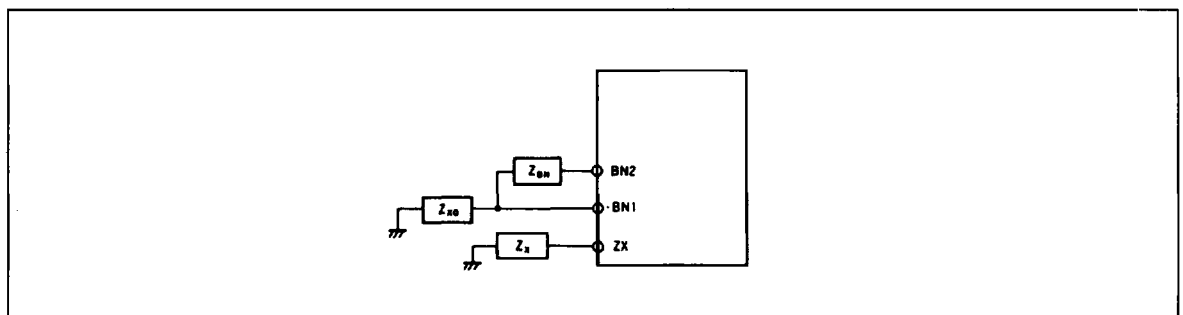

**Current Feed vs. Line Resistance characteristics**

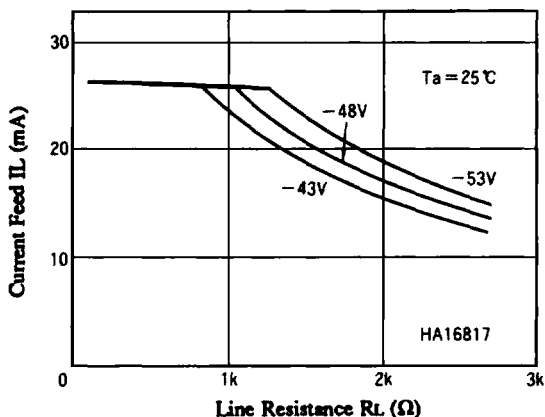

**Impedance Balance vs. Frequency Characteristics**

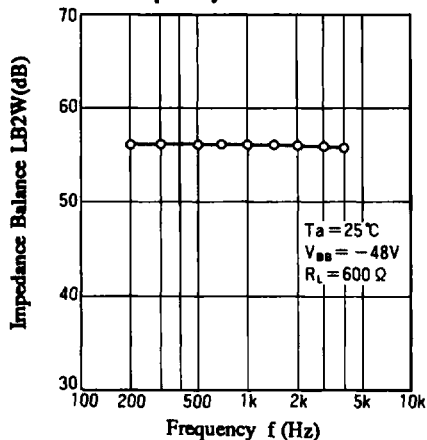

**Attenuation Distortion vs. Frequency (2W → 4W) Characteristics**

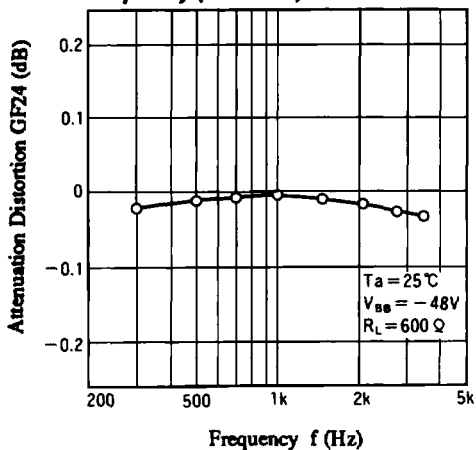

**Attenuation Distortion vs. Frequency (4W → 2W) Characteristics**

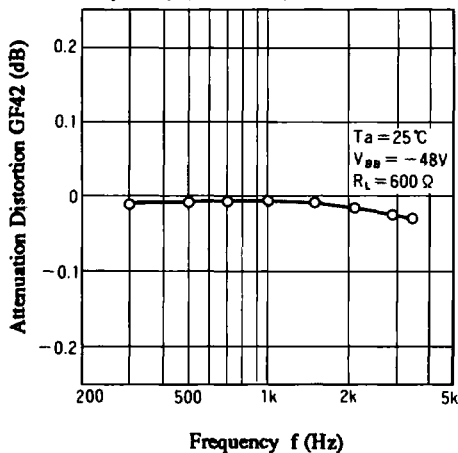

**PSRR ( $V_{BB}$ ) vs. Frequency Characteristics**

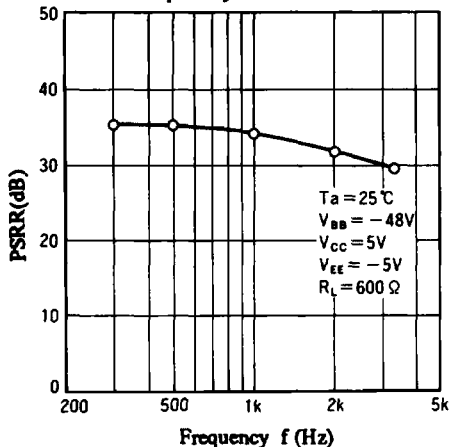

**Attenuation Distortion vs. Input (2W → 4W) Characteristics**

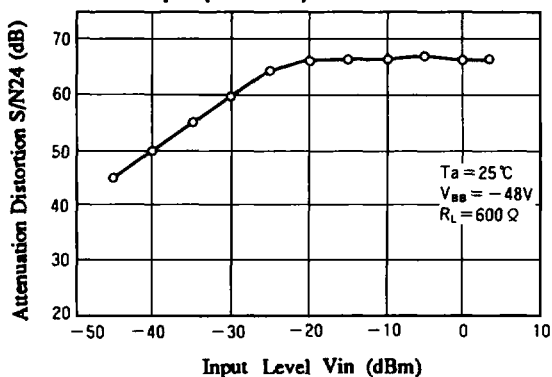

# HA16817ANT/HA16817AMP

