

NOTES:

1. MATERIALS:
ALL METAL PARTS: BRASS PER ASTM B16
INSULATOR: TEFLON PER ASTM D1710
2. FINISH:
CENTER CONTACT: .000030 MIN. GOLD PER MIL-G-45204 OVER
.000050 MIN. NICKEL PER QQ-N-290
ALL OTHER METAL PARTS: .000100 MIN. NICKEL PER QQ-N-290
OVER COPPER FLASH
3. DESIGNED FOR USE WITH HARBOUR LL-142 CABLE OR EQUIVALENT.
4. CRIMP FERRULE USING .255 HEX DIE.

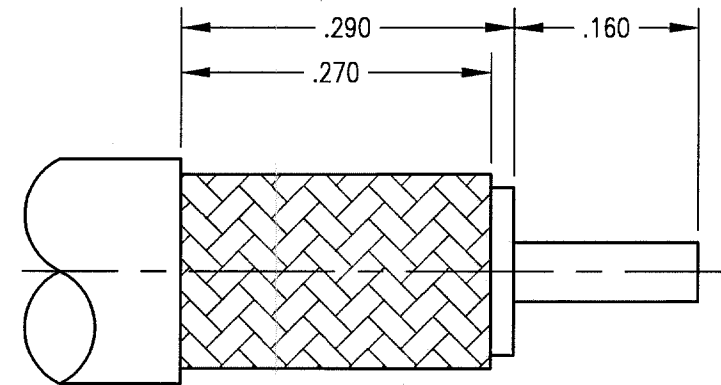

CABLE TRIMMING DIMENSIONS

THIS INFORMATION IS PROPRIETARY AND CONFIDENTIAL. IT IS DISCLOSED TO YOU ON CONDITION NO FURTHER DISCLOSURE IS MADE TO OTHER THAN RETCONN PERSONNEL WITHOUT WRITTEN AUTHORIZATION FROM RETCONN INC., TORRINGTON, CT.

UNLESS OTHERWISE SPECIFIED
ALL DIMENSIONS ARE NOMINAL AND
FOR REFERENCE ONLY.
DIMENSIONS IN INCHES
DO NOT SCALE PRINT

SALES DRAWING



RETCONN

A SUBSIDIARY OF SPM
199 W. PEARL ROAD TORRINGTON, CT. 06790
TEL. (860) 489-1220 FAX (860) 496-7307

TITLE					
SMB RIGHT ANGLE RECEPTACLE					
DRAWN	JED	DATE	4/6/99	CHECKED	107
APPR.		DWG. NO.	513-900-1162N	SCALE	6:1
FSCM OD					REV.

REV.	DESCRIPTION OF CHANGE	DATE	DRN	APPR	MATERIAL
-	RELEASED PER NPR 1312	4/6/99	JED		
REVISIONS					FINISH