



# Hi-Rel HOLD-UP MODULE HUGD-300 : 300W POWER

Hi-Rel Grade ■■

## Hold-Up Solution 9-45V & 16-80V DC/DC Converter Compatible Metallic Case

- 8 Vdc to 100 Vdc Input Voltage Range
- Compatible with 9 to 100Vdc modules
- Unique Product for Hold-Up Solution
- Reduce Capacitance by 80%
- Embedded Reverse Polarity Protection
- Power range : from 4W to 300W
- Compliant with MIL-HDBK-704-8
- Include monitoring signals
- Programmable hold up capacitor voltage
- RoHS process



### 1-General

The GAIA Converter Hold up device HUGD-300 provides a state-of-the-art solution to the problem of maintaining electronic system in operation during input bus drop-out. Usually this approach uses very large capacitors because they are only charged at the voltage at which power fails.

The Gaia Converter HUGD-300 module provides an alternative solution to reduce the amount of capacitance needed by charging the hold up capacitor at a high voltage value (adjustable from 31 to 80 VDC). It includes also a reverse polarity protection.

The HUGD-300 needs to be connected between the input line source bus and DC/DC modules. If an EMI filter and / or a pre-regulator is used, the HUGD-300 has to be connected between them and the converters.

Basically the HUGD-300 charges an external capacitor while powering the DC/DC converters. If the input voltage source bus drops out (power fail mode), the HUGD-300 powers the converter through the external capacitor.

The HUGD-300 can be used with any GAIA DC/DC converter as the capacitor voltage is externally adjustable up to 80 VDC.

The HUGD-300 features 3 modes of operations:

- Charging operation mode : when the input voltage ramps-up and reaches the start-up charge threshold (which is set at the «power fail voltage» value), the HUGD-300 begins to charge the external capacitor while powering the dc/dc converter. The charging current is limited as it is a constant power charger. When the capacitor voltage reaches 90% of it's final set value, the signal «capacitor charged» is activated and the HUGD-300 enters in the normal operation mode.

- Normal operation mode : in normal operation mode when the capacitor is charged and the input bus is between the «power fail» and 100VDC, the HUGD-300 only consumes low power to keep the capacitor charged. The HUGD-300 operates indefinitely in this state until the input voltage drops below the «power fail voltage» threshold.

- Power fail mode : when the input voltage drops below the «power fail voltage» threshold, a «power fail» signal is activated and the HUGD-300 switches converter input to the hold-up capacitor.

At this point the DC/DC converters are powered by the capacitor. When its voltage finally discharges to a value slightly above the «power fail voltage» threshold value, a «capacitor discharged» flag is activated.

### 2-Product Selection

HUGD - 300 -/  -

**Options :**

/T : option for -55°C start up operating temperature  
/S : option for screening and serialization

**Suffix :**

nothing : RoHS process

4

### 3- Block Diagram and Pin Description

The HUGD-300 module includes 3 main blocks :

- an input monitoring circuit
- an hold-up charger circuit
- a hold-up monitoring circuit

• **Input monitoring Circuit :**

The input monitoring circuit controls the value of the input bus voltage and compares it to the power fail threshold voltage ( $V_{th}$ ) set externally by a resistor. Depending on the comparison result, the circuit enables the activation of the hold-up switch or the hold-up charger and generates an open-drain «power fail flag (PF)».

• **Hold-up Charger :**

The hold-up charger is used to charge the hold-up capacitor with an adjustable constant voltage  $V_c$  that can be adjusted up to 80 Vdc. The design of this charger limits the input inrush current as the charger is a constant power charger of 30W.

• **Hold-up monitoring Circuit :**

The hold-up monitoring circuit monitors the charging status of the hold-up capacitor.

The circuit generates 2 open-drain flags : the capacitor charged flag (CC) and the capacitor discharged flag (CD).

These flags can be used at system level for power interruption management (VME system, PCI, ...).

The following diagram represents the HUGD-300 series block diagram and pins.

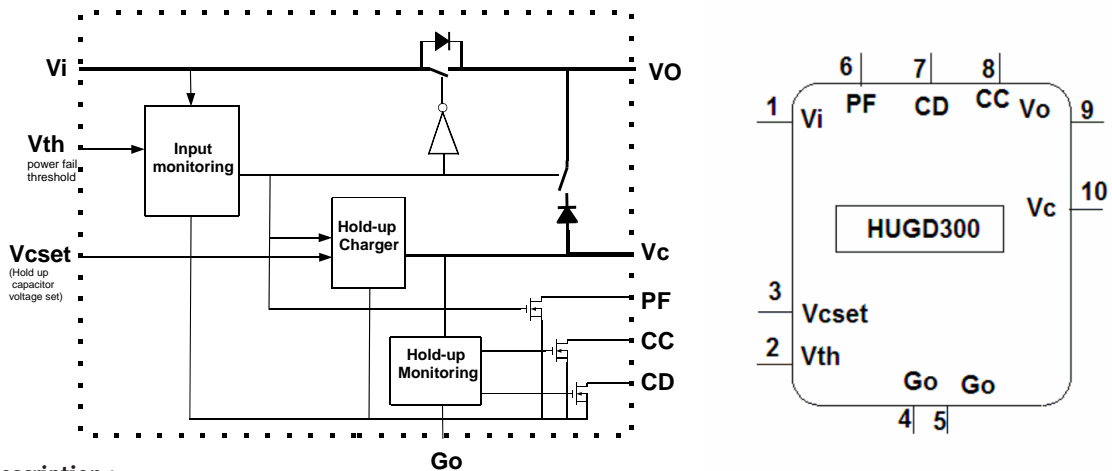

**Pin Description :**

**Power Pin :**

**Vi :** is the **+input** bus pin. Referenced to Go pin. it can accept a max permanent input voltage of 100V, and can flow permanently 30A. Reverse voltage up to 100V applied to this pin will be stopped.

**Go :** common. It the ground that is used as reference for low signal electronics and charger. This common is not involved in power circuit high current.

**Vo :** Vout it is the output power lead. Although it can drive a maximum 30A current, and 100V voltage this pin is not protected against shortage to GO. It is protected against reverse polarity below -100 volt. A transition capacitor must be connected to this pin see section 10 to avoid any transient during hold-up operation.

**Vc :** is the holdup capacitor connection. It is mandatory to have it connected to a capacitor when Vcset is not grounded.

**Control Pin :**

**Vcset :** capacitor charge voltage setting. This pin is an input referenced to Go. The voltage on this pin is proportional to the final hold-up voltage (referred as  $V_{cmax}$ ). The value of  $V_{cmax}$  range from 31 VDC to 70 VDC\* and is set by a low power resistor across Vcset and Go. (see section 10). \* contact factory for  $V_{cmax}=80$  VDC

**Vth :** this pin is an input referenced to Go. The voltage on this pin is proportional to the power fail threshold limit. The power fail threshold limit can be adjusted from 8V to 20V by connecting a low power resistor across Vth and Go.

**Monitoring Pin :**

**PF :** power fail signal is a flag active at low level that indicates the input voltage  $V_i$  has reached the value set by resistor across Vth and Go. It is an open drain topology that can draw 20mA max under 60V max.

**CD :** capacitor discharged signal is a flag that becomes active at low level when hold-up voltage has reached 120% of power fail voltage (PF voltage is set by resistor connected across Vth and Go). It is an open drain topology that can draw 20mA max under 60V max.

**CC:** capacitor charged signal is a flag that becomes active at low level when hold-up voltage has reached 90% of hold-up final voltage (set by resistor connected across Vcset and Go). It is an open drain topology that can draw 20mA max under 60V max.

## 4- Electrical Specifications

Data are valid at +25°C, unless otherwise specified.

Parameter	Conditions	Limit or typical	Units	HUGD-300
<b>Input &amp; Power</b>				
Permanent input voltage range	Full temperature range Full load	Minimum	VDC	8
		Maximum	VDC	100
Transient input voltage	Full temperature range Full load	Maximum	VDC/ms	/
Power fail voltage threshold (Vfail)	with the setting Vth connected to 100 Ohm	Minimum	VDC	6 <sup>(1)</sup>
Power fail voltage threshold (Vfail)	with the setting Vth unconnected	Maximum	VDC	20
Equivalent serie resistor in power line	Full temperature range	Nominal	mOhm	3,5
Dissipated power in normal mode	Full load 30A	Maximum	W	3,2 <sup>(2)</sup>
Output power/current	Full temperature range	Maximum	W	300
			A	or 30
<b>Charger</b>				
Charger input voltage operation range	Full temperature range Full load	Minimum	VDC	9
		Maximum	VDC	100
Set up charger start up level	Adjustable by power fail threshold	Minimum	VDC	9
		Maximum	VDC	20
Power consumption during hold up capacitance charge	Full temperature range Ui =9Vdc to 12Vdc Ui=12Vdc to Ui max.	Nominal	W	10
		Nominal	W	30
Admissible hold-up capacitor	/	Minimum	μF	470
		Maximum	μF	100 000
Adjustable hold-up capacitor final voltage	Adjustable by resistor on Vcset	Vcset adjusted (see §10)	VDC	70 <sup>(3)</sup>
<b>Control Signals</b>				
Capacitor charged signal (CC) threshold : 90% of holdup capacitor final value	Active	/	/	short drain open drain
	Non active	/	/	
Capacitor discharged signal (CD) threshold : 120% of power fail threshold	Active	/	/	short drain open drain
	Non active	/	/	
CC, CD, PF sink current max. voltage	/	Maximum	mA	20
		Maximum	VDC	60
Hold-up time at 300W load <sup>(4)</sup>	/	Nominal	μs/μF	5,6
Hold-up time at 100W load <sup>(4)</sup>	/	Nominal	μs/μF	17

Note (1) : HUGD-300 restart typically 3,5V above set power fail threshold level

Note (2) : Dissipated power can be estimated by  $0,0035 \times I_{in}^2$

Note (3) : for hold-up capacitor final voltage up to 80 Vdc consult factory

Note (4) : for charging voltage up to 80 Vdc

## 5- Switching Frequency

Characteristics	Conditions	Limit or typical	Performances
Switching frequency in boost mode	Charging capacitor	Typical	700 KHz

## 6- Isolation

Parameter	Conditions	Limit or typical	Specifications
Electric strength test voltage	Input to output	/	No isolation
Electric strength test voltage	Input to case Output to case	/	500 VDC 500 VDC

**4**

## 7- Reliability Data

Characteristics	Conditions	Temperature	Specifications
Mean Time Between Failure (MTBF) According to MIL-HDBK-217F	Ground fixed (Gf)	Case at 40°C Case at 85°C	435 000 Hrs 145 000 Hrs
	Airborne, Inhabited, Cargo (AIC)	Case at 40°C Case at 85°C	220 000 Hrs 85 000 Hrs
Mean Time Between Failure (MTBF) According to IEC-62380-TR	Civilian avionics, calculators	Ambient at 55°C 100% time on	Consult factory

## 8- Thermal Characteristics

Characteristics	Conditions	Limit or typical	Performances
Operating ambient temperature range at full load	Ambient temperature *	Minimum Maximum	- 40°C + 90°C
Operating case temperature range at full load	Case temperature	Minimum Maximum	- 40°C +105°C
Storage temperature range	Non functioning	Minimum Maximum	- 55°C + 125°C
Thermal resistance	Rth case to ambient in free air natural convection	Typical	13°C /W

Note \* : The upper temperature range depends on configuration, the user must assure a max. case temperature of + 105°C.

The HUGD-300 series operating **case** temperature must not exceed 105°C. The maximum **ambient** temperature admissible for the hold-up module corresponding to the maximum operating case temperature of 105°C depends on the ambient airflow, the mounting/orientation, the cooling features and the power dissipated.

To calculate a maximum admissible ambient temperature the following method can be used. Knowing the maximum case temperature Tcase = 105°C of the module, the input current Iin and the ESR (equivalent serie resistance) :

- determine the power dissipated by the module P<sub>diss</sub> that should be evacuated :

$$P_{diss} = ESR \times I_{in}^2$$

- determine the maximum ambient temperature :

$$T_a = 105^\circ\text{C} - R_{th} \times P_{diss}$$

where **Rth** is the thermal resistance from the case to ambient.

The previous thermal calculation shows two areas of operation :

- a normal operation area in a free natural ambient convection (grey area in this following graph),
- an area with cooling features (air flow or heatsink) ensuring a maximum case temperature below the maximum operating case temperature of 105°C (white area in the following graph).

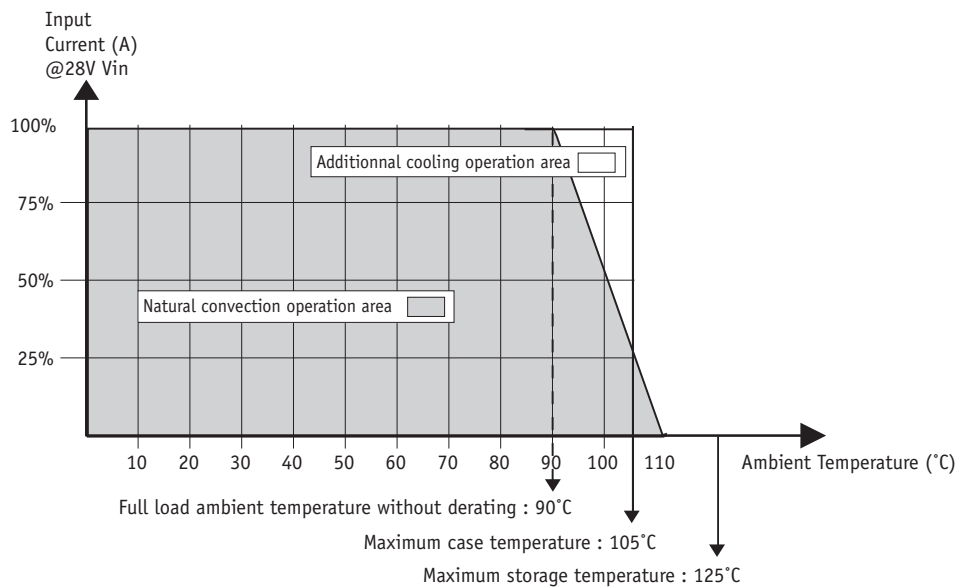



## 9- Environmental Qualifications

The modules have been subjected to the following environmental qualifications.

Characteristics	Conditions	Severity	Test procedure
<b>Climatic Qualifications</b>			
Life at high temperature	Duration Temperature / status of unit	Test D : 1 000 Hrs @ 105°C case, unit operating @ 125°C ambient, unit not operating	MIL-STD-202G Method 108A
Altitude	Altitude level C Duration Climb up Stabilization Status of unit	40 000 ft@-55°C 30 min. 1 000 ft/min to 70 000 ft@-55°C, 30 min. unit operating	MIL-STD-810E Method 500.3
Humidity cyclic	Number of cycle Cycle duration Relative humidity variation Temperature variation Status of unit	10 Cycle I : 24 Hrs 60 % to 88 % 31°C to 41°C unit not operating	MIL-STD-810E Method 507.3
Humidity steady	Damp heat Temperature Duration Status of unit	93 % relative humidity 40°C 56 days unit not operating	MIL-STD-202G Method 103B
Salt atmosphere	Temperature Concentration NaCl Duration Status of unit	35°C 5 % 48 Hrs unit not operating	MIL-STD-810E Method 509.3
Temperature cycling	Number of cycles Temperature change Transfer time Steady state time Status of unit	200 -40°C / +85°C 40 min. 20 min. unit operating	MIL-STD-202A Method 102A
Temperature shock	Number of shocks Temperature change Transfer time Steady state time Status of unit	100 -55°C / +105°C 10 sec. 20 min. unit not operating	MIL-STD-202G Method 107G
<b>Mechanical Qualifications</b>			
Vibration (Sinusoidal)	Number of cycles Frequency / amplitude Frequency / acceleration Duration Status of unit	10 cycles in each axis 10 to 60 Hz / 0.7 mm 60 to 2 000 Hz / 10 g 2h 30 min. per axis unit not operating	MIL-STD-810D Method 514.3
Shock (Half sinus)	Number of shocks Peak acceleration Duration Shock form Status of unit	3 shocks in each axis 100 g 6 ms 1/2 sinusoidal unit not operating	MIL-STD-810D Method 516.3
Bump (Half sinus)	Number of bumps Peak acceleration Duration Status of unit	2 000 Bumps in each axis 40 g 6 ms unit not operating	MIL-STD-810D Method 516.3

## 10- Application Notes

### 10-1 General on Input Bus Shut-Down Requirements

During bus power drop-out, avionics and military systems require a maintain of operation for data saving and shut-down control. The duration of this shut-down operation is defined in different standards and can last up to 7 secondes.

#### 10-1-1 Capacitor Stand-Alone Solution

To maintain operation during power drop-out, the traditional approach is to use a bulk capacitor connected at the input of the converters to power them when power drops-out. This capacitor depends on the system specifications, the load, the efficiency of the DC/DC converter and the hold-up time requirement. The value of the capacitance is determined by the following formula :

$$C1 = \frac{2 \times P \times Dt}{(V1^2 - V2^2)}$$

where :

- C : is the required capacitor (in farads)
- P : is the consumed power (at HUGD output) (in watts)
- Dt : is the required hold up time (in seconds)
- V1 : is the initial charged capacitor voltage (in volts)
- V2 : is the low line voltage of DC/DC converter

For a typical 100ms hold-up time requirement on a 200W output DC/DC converter with 80% efficiency - i.e 250W consumed power- with a minimum permanent input voltage of 9V connected on a MIL-STD-704 28V bus that can range down to 22V, the resulting capacitor is a large  $(2 \times 250 \times 0,1) / ((28^2 - 9^2)) = 72\ 150\ \mu\text{F}$  so a 82 000  $\mu\text{F}/40\text{V}$  bulk capacitor or even larger if we consider the initial voltage as the minimum permanent input bus voltage (i.e 22V).

Using stand alone capacitor conduct to face 2 main issues:

- 1) Voltage before interruption (V1) follows the input bus minimum steady state, reducing by the way the stored energy when bus is at its low value. In some case the hold-up is not possible because  $V1 < V2$ .
- 2) Needed hold-up capacitor value are so large than inrush current at 1<sup>st</sup> step of charging need to be limited by a power resistor .

In consequence the typical schematic for stand alone capacitor value is as described below:

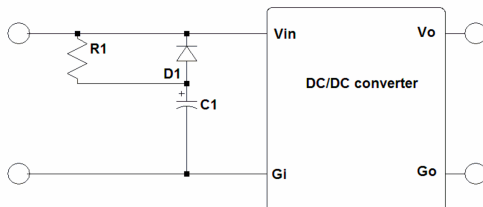

- D1 = Hold-up mode diode
- C1 = Hold-up capacitor

#### 10-1-2 Capacitor with Hold Up Module Solution

To reduce drastically the size of this capacitor, GAIA Converter proposes the HUGD-300 hold-up module that will charge the capacitor at a higher voltage from 31V to 80VDC.

Moreover this module also allows to select the minimum threshold voltage at which the capacitance will power the converters. In this case the amount of capacitance needed for a given hold up time is determined by the following formula :

$$C2 = \frac{2 \times P \times Dt}{(Vcset^2 - V2^2)}$$

where :

- C : is the required capacitor (in farads)
- P : is the consumed power (at HUGD output) (in watts)
- Dt : is the required hold up time (in seconds)
- Vcset : is the capacitor charge voltage set from HUGD-300
- V2 : is the low line voltage of DC/DC converter (in volts).

**4**

For a typical 100ms hold-up time requirement on a 200W output DC/DC converter with 80% efficiency - i.e 250W consumed power- with a minimum permanent input voltage of 16VDC connected on a MIL-STD-704 standard 28V bus, using the HUGD-300 set for a capacitor charge voltage of 70VDC will reduce the capacitance value down to  $(2 \times 250 \times 0,1) / ((70^2 - 16^2)) = 10\ 767\ \mu\text{F}$  so a typical 12.000  $\mu\text{F}/100\text{V}$  bulk capacitor.

The HUGD-300 takes the advantage of boosting hold-up cap. voltage to enlarges the V1-V2 voltage difference whatever the input bus voltage before hold-up is.

The gain is not proportional to V but to  $V^2$  so stored energy is growing according to a quadratic curve. In addition HUGD-300 manages the inrush current without necessity of external power resistor.

## 10- Application Notes (continued)

### 10-2 Hold-up Capacitor Selection with HUGD-300 Solution

The external capacitor supplies the energy for the DC/DC converters operation during power drop-out. The capacitance should not exceed 100.000µF, and should not be lower than 470µF. The amount of capacitance for a given hold up time is given by the formula :

$$C = \frac{2 \times P \times Dt}{V_{cset}^2 - V_L^2}$$

where

- C : is the required capacitance (in Farads)
- P : is the power consumed by the DC/DC converters (in Watts)
- Dt : is the required hold-up time (in seconds)
- Vcset : is the capacitor charge voltage set up
- V<sub>L</sub> : is the lowest admissible voltage of DC/DC converters (in volts)

The following curves give the hold-up time (or transparency time) as a function of the capacitance value for 2 values of setting Vcset (45 VDC and 80 VDC) in conjunction with adapted GAIA Converter module families i.e 9-45 Vdc and 16-80 Vdc input range. Gaia Converter recommends low ESR extended temperature range electrolytic capacitor.

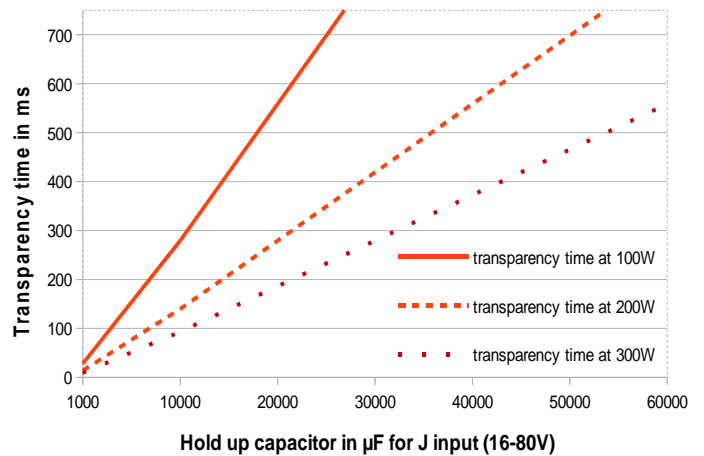
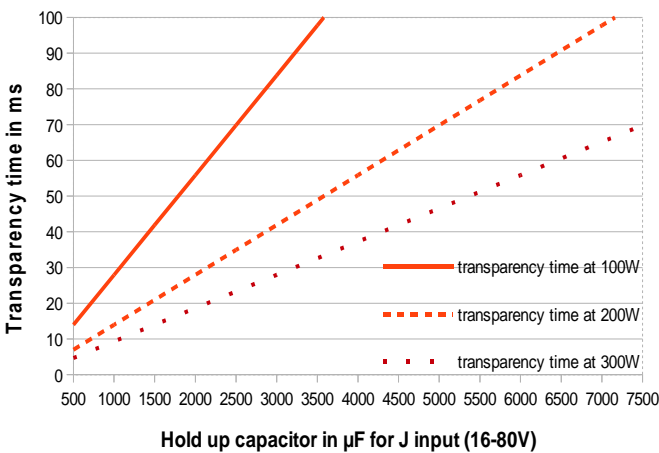
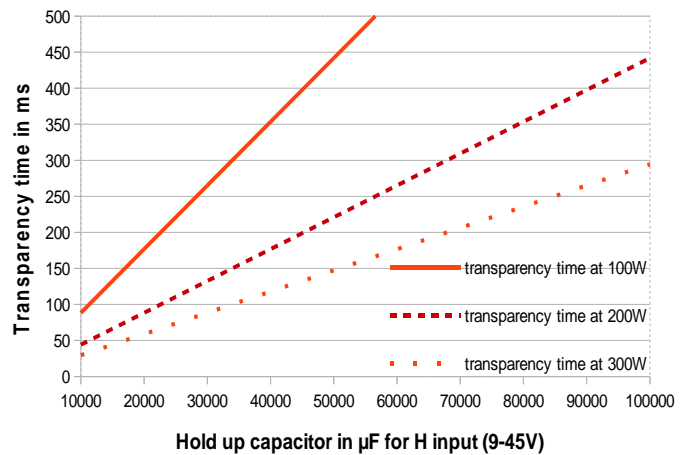
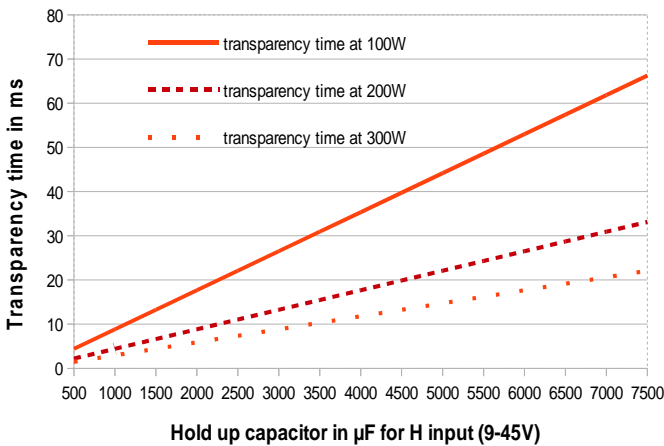



## 10- Application Notes (continued)

### 10-3 Power Fail Voltage Threshold : Vth

The «power fail voltage» threshold determines the operation mode of the HUGD-300.

This threshold has to be set up in conjunction with the type of modules used (i.e. 9-36/9-45 VDC, 10-100 VDC or 16-40/16-80 VDC input voltage type of modules) and can be adjusted between 8 VDC and 20 VDC by an external resistor Rth connected between the Vth pin and Go pin. Vth unconnected will set the threshold at 20 VDC whereas Vth connected to ground will set the threshold at 5 VDC. The following curve shows the Vth function threshold as a function of the resistor Rth.

The hysteresis on the undervoltage detection is typically 3,5 VDC. Once an undervoltage has been detected and the input bus has been disconnected to switch on the hold-up capacitor energy reservoir, the HUGD-300 will reconnect the input bus when it is 3,5 VDC above the value set with the Vth pin. Therefore, it is recommended to minimize the series resistance of elements in front of the HUGD-300 to prevent false triggerings when the input current becomes 0A as the Vth threshold is reached and the bus is disconnected, because the voltage at the input of the HUGD-300 will then slightly increase. The resulting unwanted bounces may lead to a loss of stored energy and internal switch overstress. The series resistance should be kept below  $2 \times Vth / Pout$ .

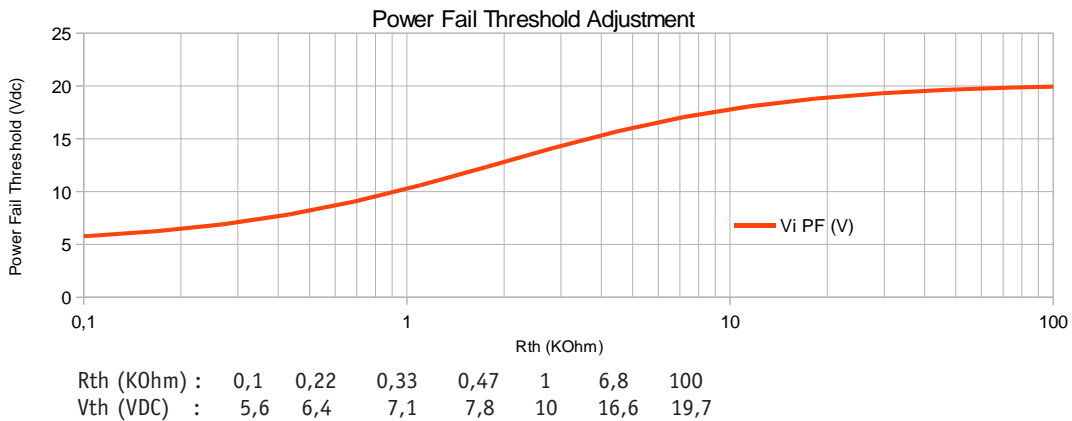

### 10-4 Hold up Capacitor Charge Voltage Setting and Charging Time : V<sub>cset</sub>

The HUGD-300 controls the hold-up capacitor charge voltage between 31 VDC to 80 VDC by an external resistance Rcl connected between the Vcset pin and Go pin.

Shorting Vcset to Go disables the charger.

The charging time will be given by the following formula from a capacitor at 0 VDC and is compliant with multiple interruption test given in MIL-HDBK-704E/F condition J :

$$T_{charge} = \frac{C \times V_{cset}^2}{2 \times P_{charging}}$$

where :

Pcharging : is the charging power (30W constant at hold-up capacitor)

C : is the hold-up capacitor (in farads)

Vcset : is the final capacitor voltage set

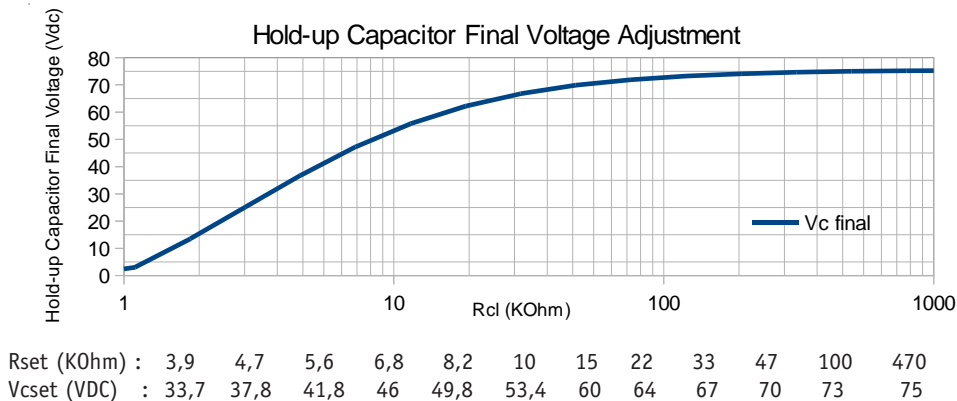

## 10- Application Notes (continued)

### 10-5 Power Fail Signal : PF

The «power fail» output signal is activated when the voltage drops below the power fail voltage threshold. The PF signal is an active low open-drain output.

### 10-6 Capacitor Discharged Signal : CD

The «Capacitor discharged» signal is activated when the voltage at the hold-up capacitor pin reaches 120% of the power fail threshold programmed with the Vth pin to inform the system that the energy storage capacitor voltage is closed to the value which is considered a «power fail» event. It can be used as a last warning before system shut-off. With the Vth pin unconnected, the corresponding value will be 24V, whereas with the Vth pin grounded, the corresponding value will be  $V_c = 7.2V$ . The CD signal is an open drain active low output.

### 10-7 Capacitor Charged Signal : CC

The «capacitor charged» signal is activated when the voltage at the capacitor pins reaches 90% of hold up capacitor charge voltage setting Vcset corresponding to an energy stored of about 80% of it's full charge. The CC signal is an active low open-drain output.

### 10-8 Transition Capacitor

To help transitionning the system in the different operating mode, GAÏA Converter recommends the use of a transition capacitor. This capacitor is used to maintain output voltage during the HUGD-300 switching from input line to hold up capacitor. A 220  $\mu F$  electrolytic capacitor is enough for a 300W load, and this value can be reduced for lower loads.

The table below gives the minimum required values versus output power :

Output power (W)	100W	200W	300W
Capacitance value ( $\mu F$ )	68	110	220

### 10-9 Typical Schematics

This typical application schematics includes an EMI filter, a LGDS-300 pre-regulator, the hold-up module and an assembly of standard DC/DC converters. Additional details are given in the EMI filters application notes and LGDS-300 datasheet. Please note that for compatibility reasons it is not recommended to use in this architecture power modules such as MGDM-04 MGDM-10, MGDM-18 or MGDM-20 series.

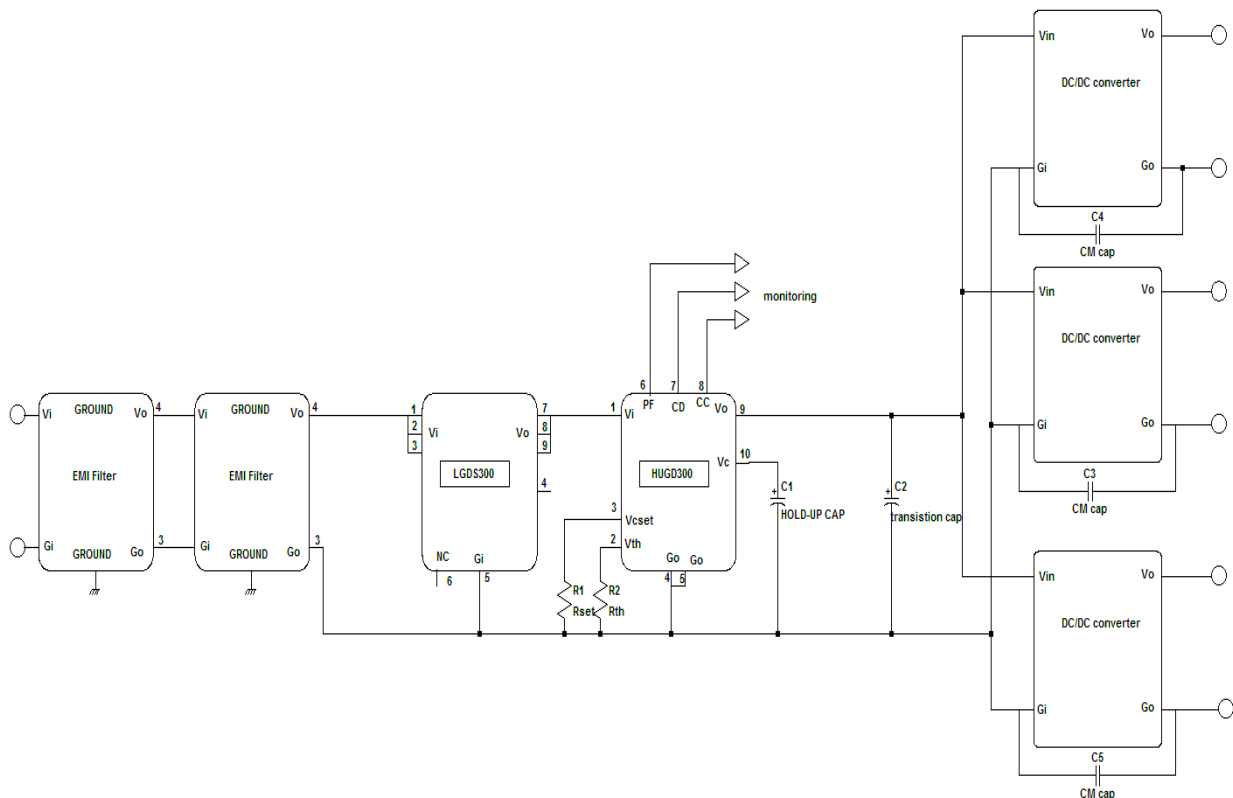

## 10- Application Notes (continued)

### 10-10 Timing Diagram

The following diagram describes the HUGD-300 output signals through the different operation modes :

- Input voltage ( $V_i$ )
- Output voltage to DC/DC converter ( $V_o$ )
- Capacitor voltage ( $V_c$ )
- Power Fail signal (PF)
- Capacitor charged signal (CC)
- Capacitor discharge signals (CD)

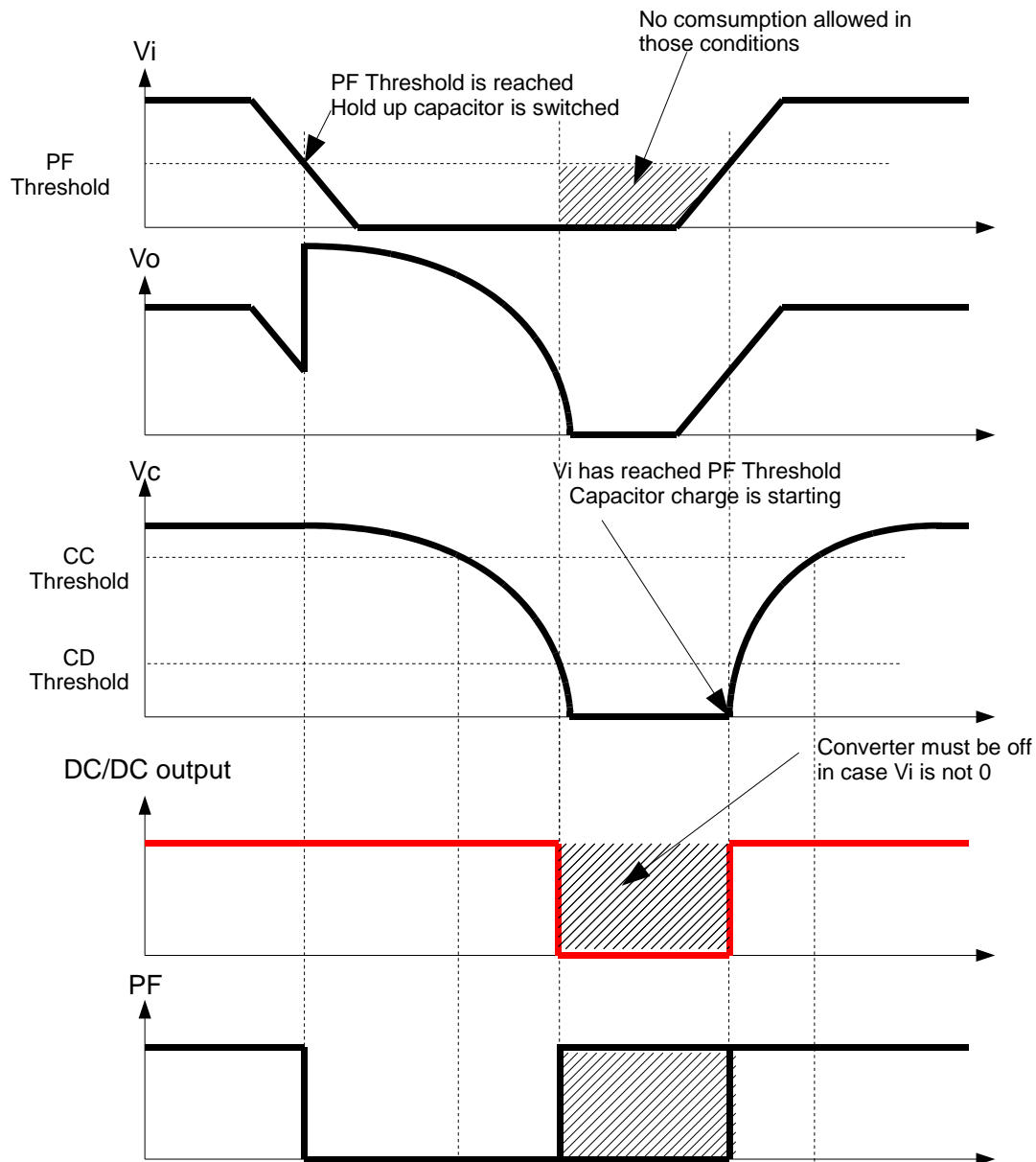

## 10- Application Notes (continued)

### 10-11 Minimum Input Impedance

As the HUGD-300 input lead  $V_i$  is connected to the HUGD-300 internal serial switch, this  $V_i$  pin must maintained at a fix potentiel during interruption phase. If the bus impedance during interruption phase is not known, it is recommended to implement a 5,6 Khom/250mW min resistor across  $V_{in}$  and  $G_{in}$  as shown herefater

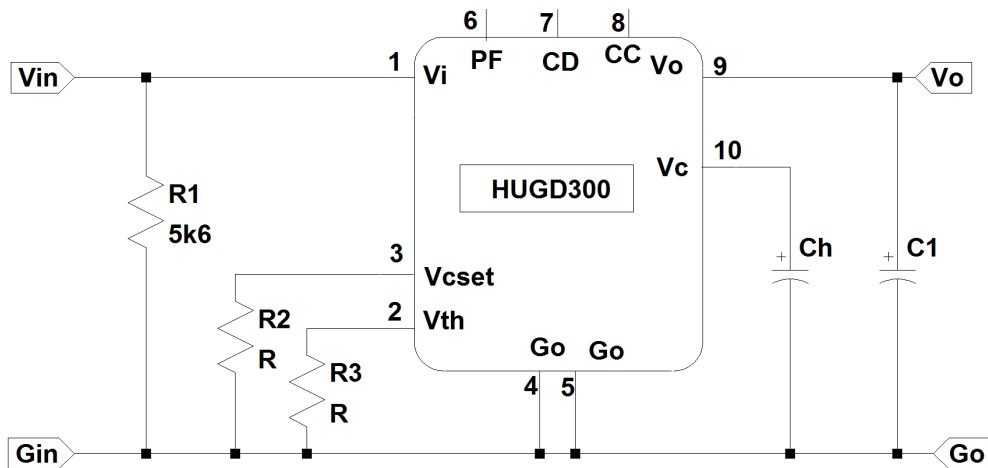

- R1 = 5,6k
- R2 = Hold up cap final voltage trimming
- R3 = power fail voltage trimming resistor
- Ch = Hold up capacitor
- C1 = transition capacitor

## 11- Dimensions

Dimension are given in mm (inches). Tolerance : +/- 0,2 mm (+/- 0.01 ") unless otherwise indicated.  
Weight : 30 grams (1.05 Ozs) max.

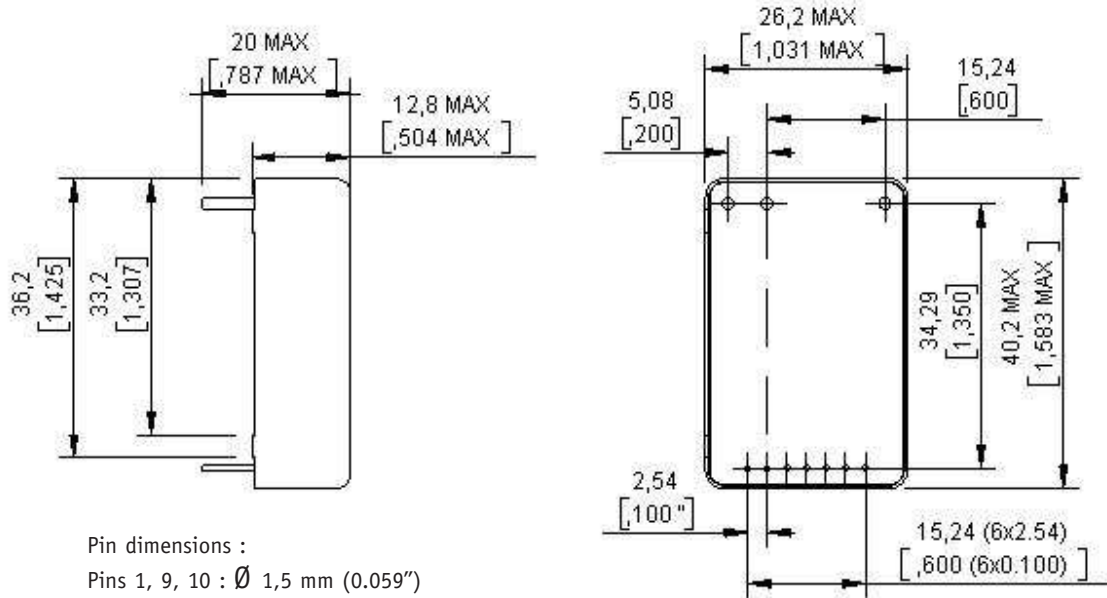

Pin dimensions :  
Pins 1, 9, 10 :  $\varnothing$  1,5 mm (0.059")  
Pins 2, 3, 4, 5, 6, 7, 8 :  $\varnothing$  0,73 mm (0.029")

## 12- Materials

Case : Metallic black anodized coating.  
Pins : Plated with gold flash over nickel underplate.

## 13- Product Marking

Upper face : Company logo.  
Side face : Module reference : HUGD-300.  
Date code : year and week of manufacturing, suffix, /option.

## 14- Connections

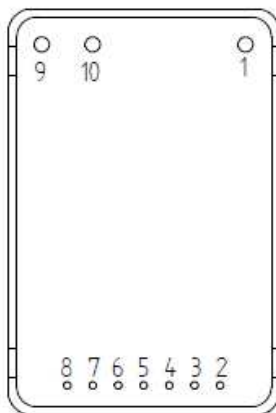

Pin	HUGD-300
1	+ Input (Vi)
2	Power Fail Set (Vth)
3	Capacitor Charge Voltage Set (Vcset)
4	Common (Go)
5	Common (Go)
6	Power Fail Signal (PF)
7	Capacitor discharged signal (CD)
8	Capacitor charged signal (CC)
9	Output (Vo)
10	Voltage Capacitor (Vc)



For more detailed specifications and applications information, contact :

<b>International Headquarters</b>	<b>North American Headquarters</b>
GAIA Converter - France	GAIA Converter Canada, Inc
ZI de la Morandière	4038 Le Corbusier Blvd
33185 LE HAILLAN - FRANCE	LAVAL, QUEBEC - CANADA H7L 5R2
Tel. : + (33)-5-57-92-12-80	Tel. : (514)-333-3169
Fax : + (33)-5-57-92-12-89	Fax : (514)-333-4519

Represented by :