

Enable High Flux and Cost Efficient System

Acrich Chip on Board – AC COB series

SAW814K2AB, SAW914K2AB

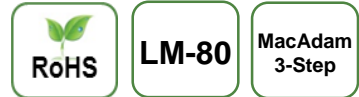

Product Brief

Description

- Acrich COB are LED arrays which provide High Flux and High Efficacy.
- It's possible to use not only the COB on Printed Circuit Board but also the individual COB by eliminating reflow soldering process.
- Especially It is optimized for the Acrich module which is designed to compact size.
- It's thermal management is better than other power LED solutions with wide metal area.
- Acrich COB are ideal light sources for general lighting applications including Replacement Lamps, Industrial & Commercial Lightings and other high lumen required applications.

Features and Benefits

- Size 19.0mm x 19.0mm
- Structure Ceramic Chip on Board
- Chromaticity Range
MacAdam 2-step, 3-step binning
- Thermal Resistance 1.3K/W at Tj=85°C
- High Color quality with CRI
Min.80(R9>0), Min.90(R9>50)
- SMT solderable
- Uniformed Shadow
- Excellent Thermal management
- RoHS compliant

Key Applications

- Replacement Lamps – Bulb
- Commercial – Downlight, Spot light
- Residential

Table 1. Product Selection Table

| Part Number | CCT | | | |
|-------------|---------------|-------|------|-------|
| | Color | Min. | Typ. | Max. |
| SAW814K2AB | Cool White | 4700K | - | 7000K |
| | Neutral White | 3700K | - | 4200K |
| | Warm White | 2600K | - | 3700K |
| SAW914K2AB | Neutral White | 3700K | - | 4200K |
| | Warm White | 2600K | - | 3700K |

Table of Contents

| Index | |
|---------------------------------------|----|
| • Product Brief | 1 |
| • Table of Contents | 2 |
| • Performance Characteristics | 3 |
| • Characteristics Graph | 5 |
| • Color Bin Structure | 15 |
| • Mechanical Dimensions | 17 |
| • Recommended Solder Pad | 19 |
| • Reflow Soldering Characteristics | 20 |
| • Packing Specification | 21 |
| • Product Nomenclature | 23 |
| • Handling of Silicone Resin for LEDs | 24 |
| • Precaution for Use | 25 |
| • Company Information | 28 |

Performance Characteristics

Table.2 Electro Optical Characteristics, $T_j=85^\circ\text{C}$

| Part Number | CCT (K) ^[1] | Typical Luminous Flux ^[2] Φ_v ^[3] (lm) | Typical Forward Voltage (V_F) ^[4] | CRI ^[5] , R_a | Viewing Angle (degrees) $2\theta_{1/2}$ |
|-------------|------------------------|--|--|-------------------------------|--|
| | Typ. | 0.24A | 0.24A | Min. | Typ. |
| SAW814K2AB | 6500 | 4280 | 117 | 80 | 118 |
| | 5700 | 4350 | 117 | 80 | 118 |
| | 5000 | 4390 | 117 | 80 | 118 |
| | 4000 | 4450 | 117 | 80 | 118 |
| | 3500 | 4320 | 117 | 80 | 118 |
| | 3000 | 4230 | 117 | 80 | 118 |
| | 2700 | 4090 | 117 | 80 | 118 |
| SAW914K2AB | 4000 | 3840 | 117 | 90 | 118 |
| | 3500 | 3740 | 117 | 90 | 118 |
| | 3000 | 3650 | 117 | 90 | 118 |
| | 2700 | 3490 | 117 | 90 | 118 |

Table 3. Typical Forward Voltage by LED Group. $I_F=0.24\text{A}$ $T_j=85^\circ\text{C}$

| Part Number | Typical Forward Voltage by LED Group (V) | | | |
|-------------|--|-------------|-------------|-------------|
| | LED Group 1 | LED Group 2 | LED Group 3 | LED Group 4 |
| SAWx14K2AB | 29.3 | 29.3 | 29.3 | 29.3 |

Notes :

- (1) Correlated Color Temperature is derived from the CIE 1931 Chromaticity diagram.
Color coordinate : ± 0.005 , CCT $\pm 5\%$ tolerance.
- (2) Seoul Semiconductor maintains a tolerance of $\pm 7\%$ on flux and power measurements.
- (3) Φ_v is the total luminous flux output as measured with an integrating sphere.
- (4) Tolerance is $\pm 3\%$ on forward voltage measurements.
- (5) Tolerance is ± 2 on CRI measurements.

* No values are provided by real measurement. Only for reference purpose.

Performance Characteristics

Table.4 Absolute Maximum Ratings, $T_j=85^\circ\text{C}$

| Parameter | Symbol | Value | | | Unit |
|--|-----------------|-------|------|------|------------------|
| | | Min. | Typ. | Max. | |
| Forward Current | I_F | - | 0.24 | 0.32 | A |
| Power Dissipation | P_d | - | 30 | 40 | W |
| Junction Temperature | T_j | - | - | 140 | $^\circ\text{C}$ |
| Operating Temperature | T_{opr} | - 40 | - | 100 | $^\circ\text{C}$ |
| Surface Temperature | T_s | - 40 | - | 105 | $^\circ\text{C}$ |
| Storage Temperature | T_{stg} | - 40 | - | 105 | $^\circ\text{C}$ |
| Thermal resistance (J to S) ⁽¹⁾ | $R\theta_{J-S}$ | - | 1.3 | - | K/W |

Notes :

- (1) At thermal Resistance, J to S means junction to COB's ceramic PCB bottom.
- (2) Thermal resistance : $R\theta_{J-S}$ (Junction / solder)

- LED's properties might be different from suggested values like above and below tables if operation condition will be exceeded our parameter range. Care is to be taken that power dissipation does not exceed the absolute maximum rating of the product.
- Thermal resistance can be increased substantially depending on the heat sink design/operating condition, and the maximum possible driving current will decrease accordingly.
- All measurements were made under the standardized environment of Seoul Semiconductor..

Characteristics Graph

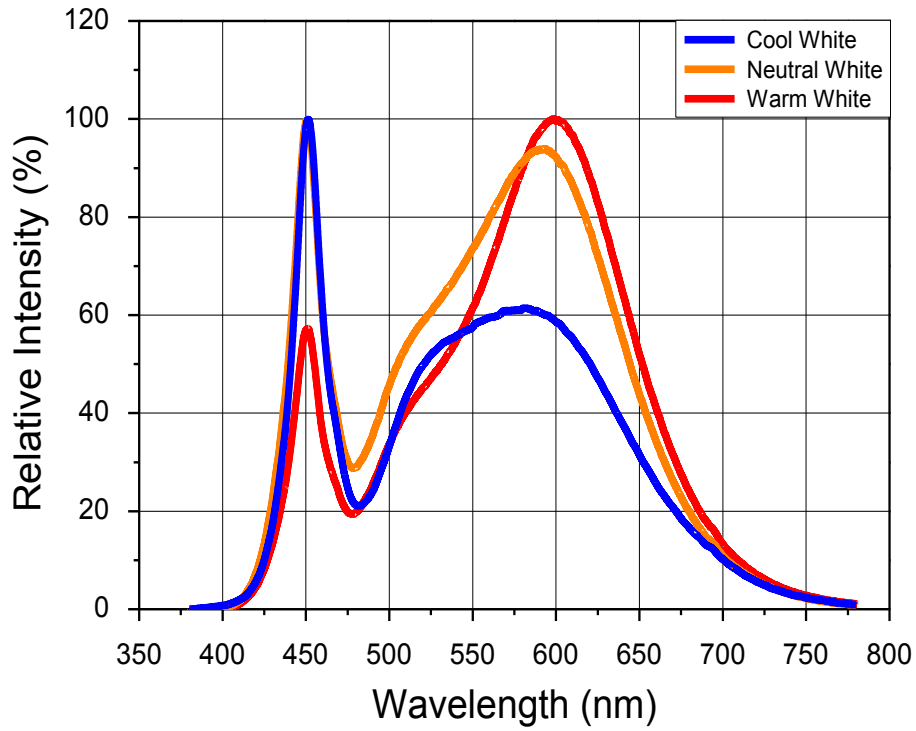
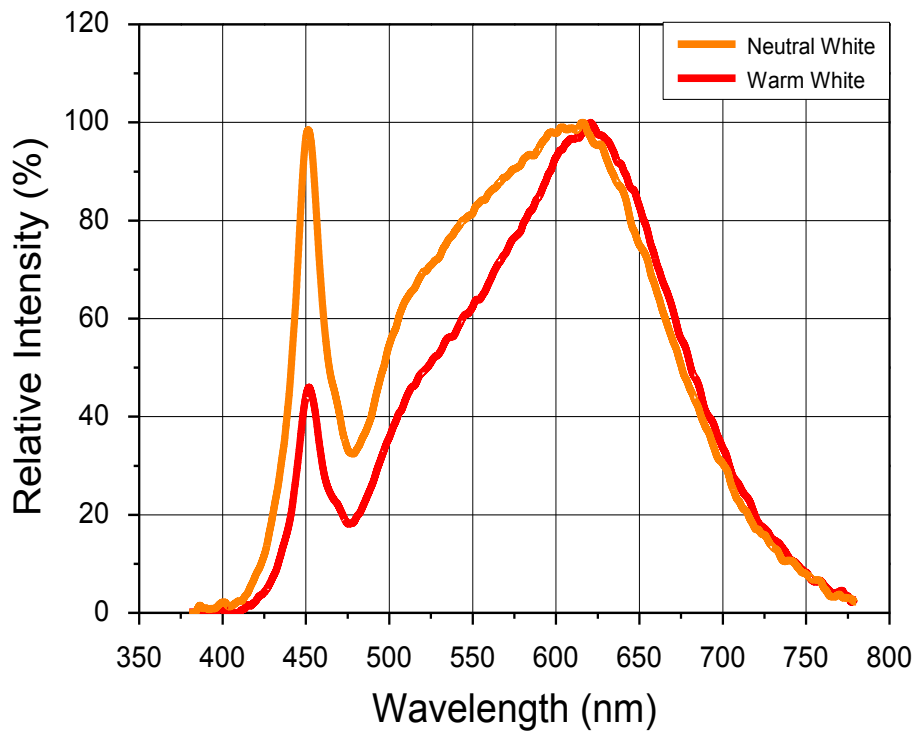
Fig 1. Color Spectrum, CRI80

Fig 2. Color Spectrum, CRI90

Characteristics Graph

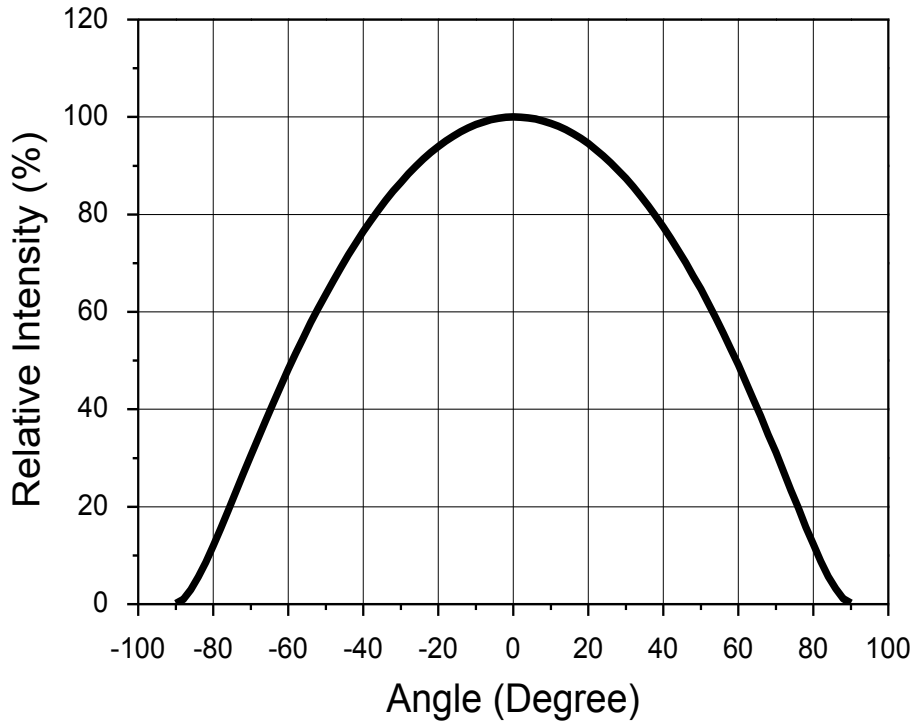
Fig 3. Radiant Pattern, $I_F = 0.24A$



Characteristics Graph

Fig 4. Forward Voltage vs. Forward Current, $T_j=85^\circ\text{C}$

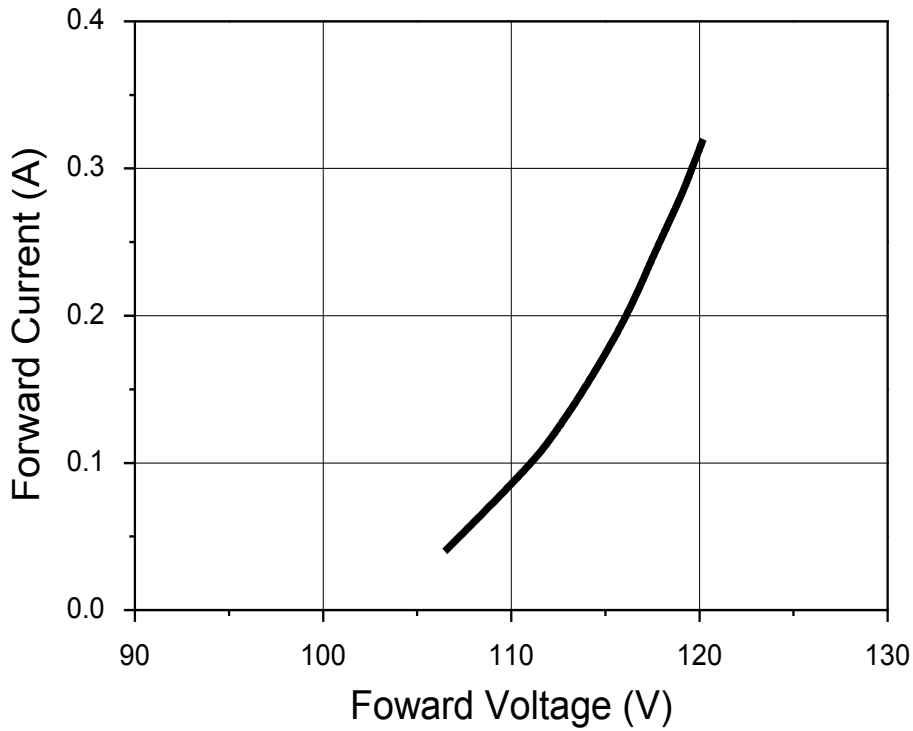
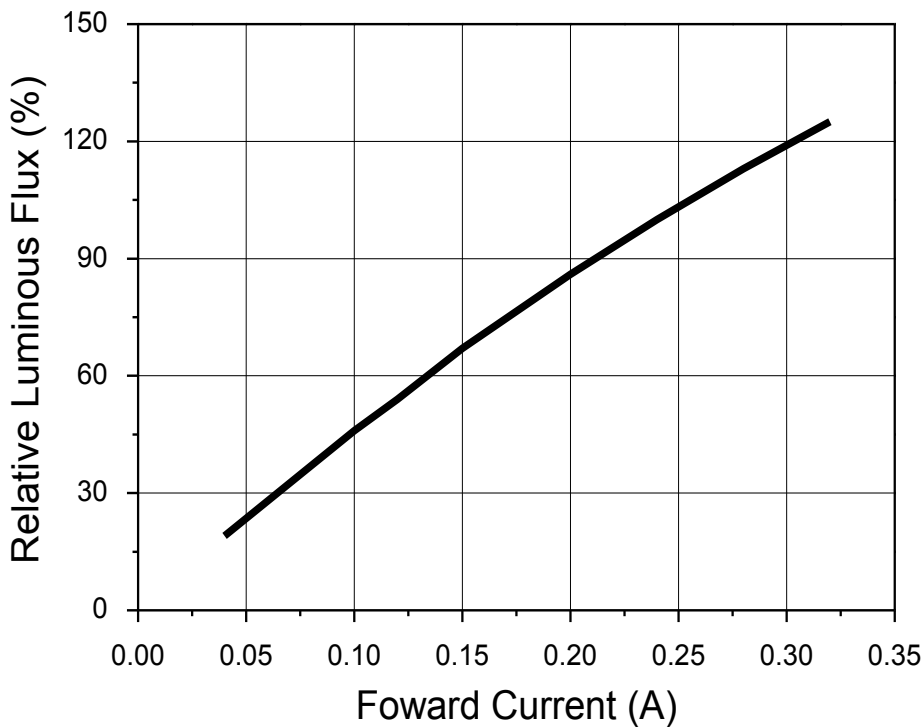

Fig 5. Forward Current vs. Relative Luminous Flux, $T_j=85^\circ\text{C}$



Characteristics Graph

Fig 6. Forward Current vs. CIE x,y Shift (CRI80, Cool White)

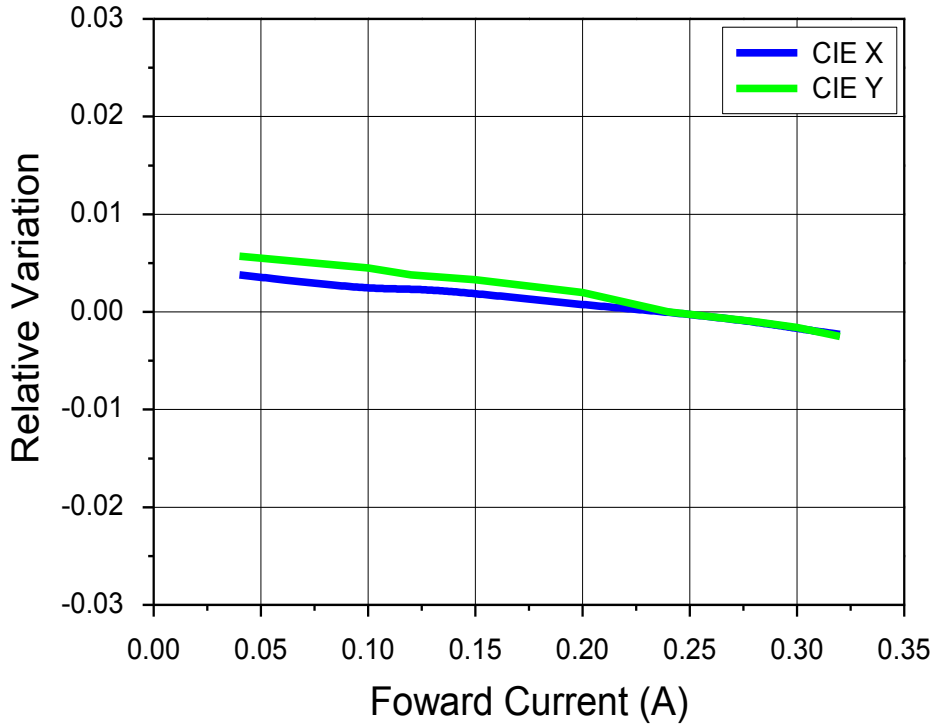
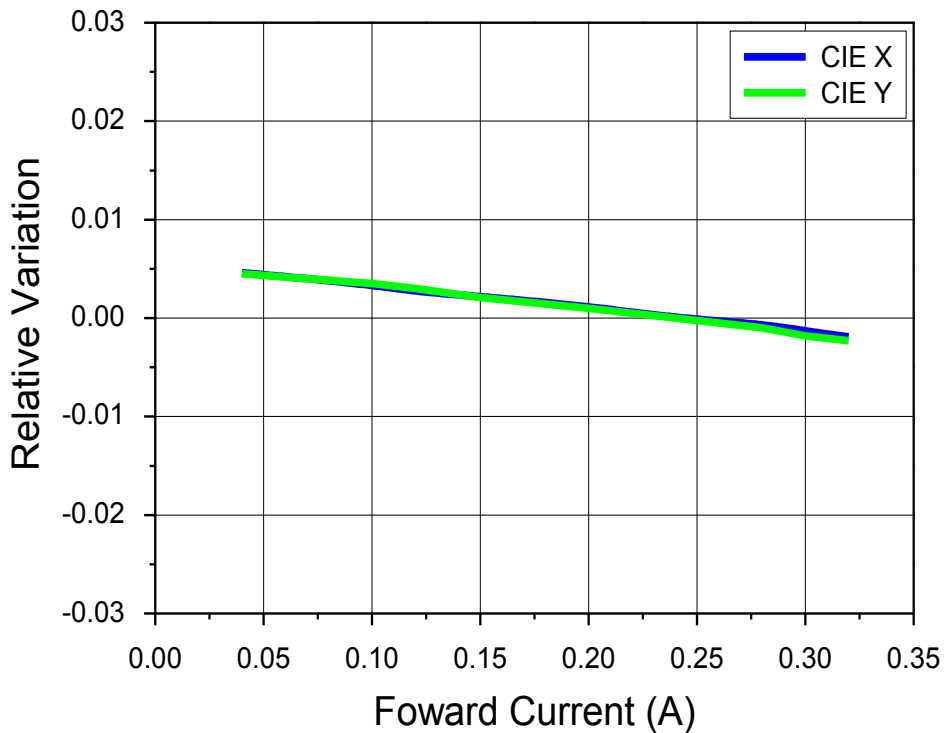

Fig 7. Forward Current vs. CIE x,y Shift (CRI80, Neutral White)



Characteristics Graph

Fig 8. Forward Current vs. CIE x,y Shift (CRI80, Warm White)

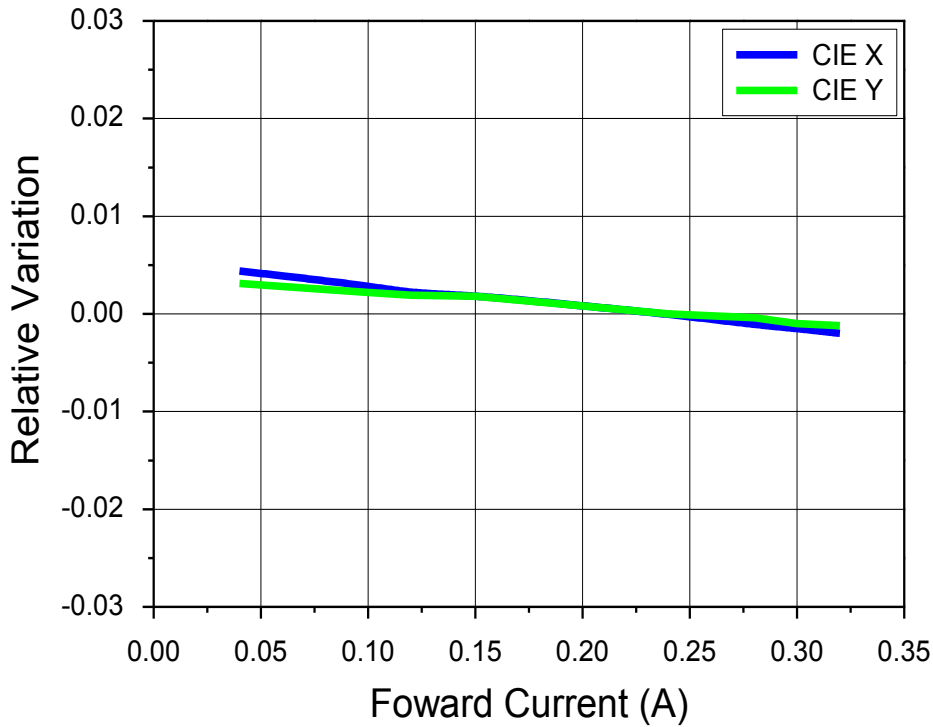
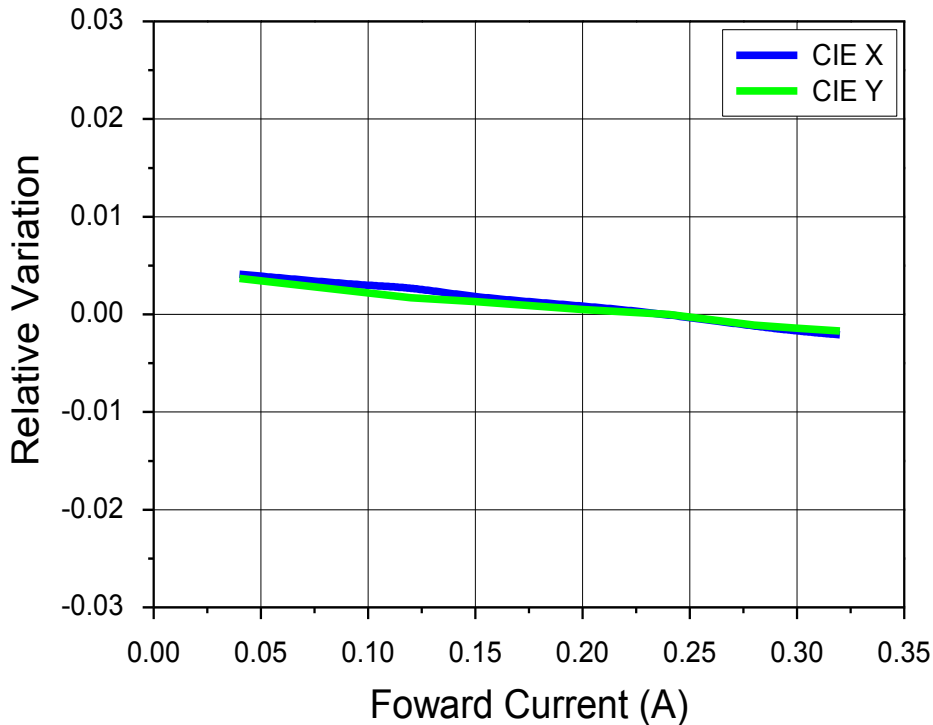
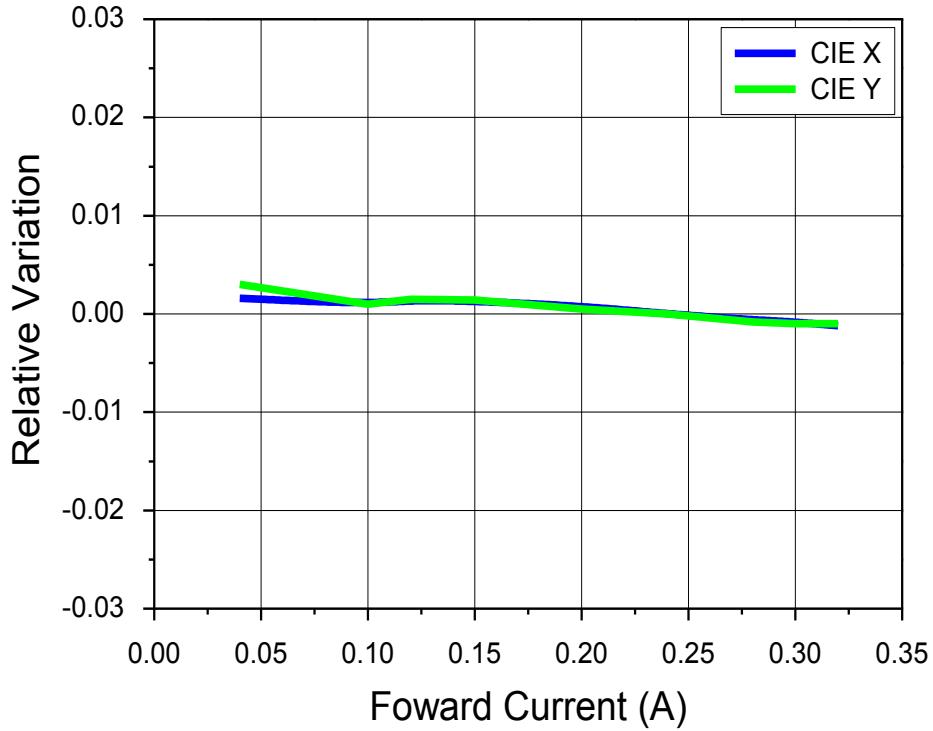

Fig 9. Forward Current vs. CIE x,y Shift (CRI90, Neutral White)



Characteristics Graph

Fig 10. Forward Current vs. CIE x,y Shift (CRI90, Warm White)



Characteristics Graph

Fig 11. Junction Temperature vs. Forward Voltage, $I_F=0.24A$

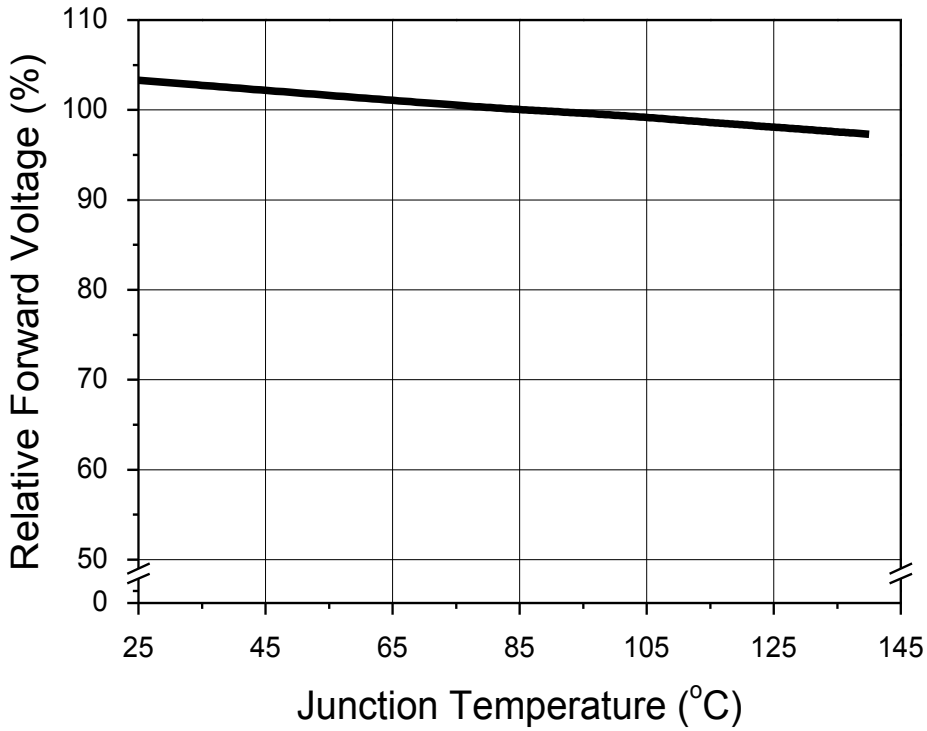
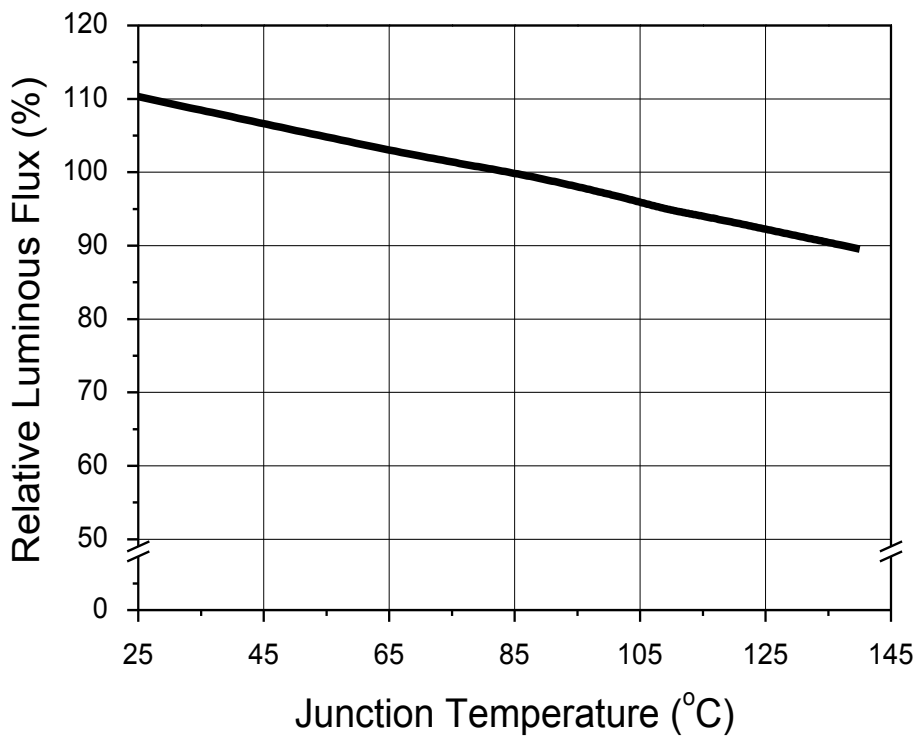

Fig 12. Junction Temperature vs. Relative Luminous Flux, $I_F=0.24A$



Characteristics Graph

Fig 13. Junction Temperature vs. CIE x,y Shift, $I_f=0.24A$ (CRI80, Cool White)

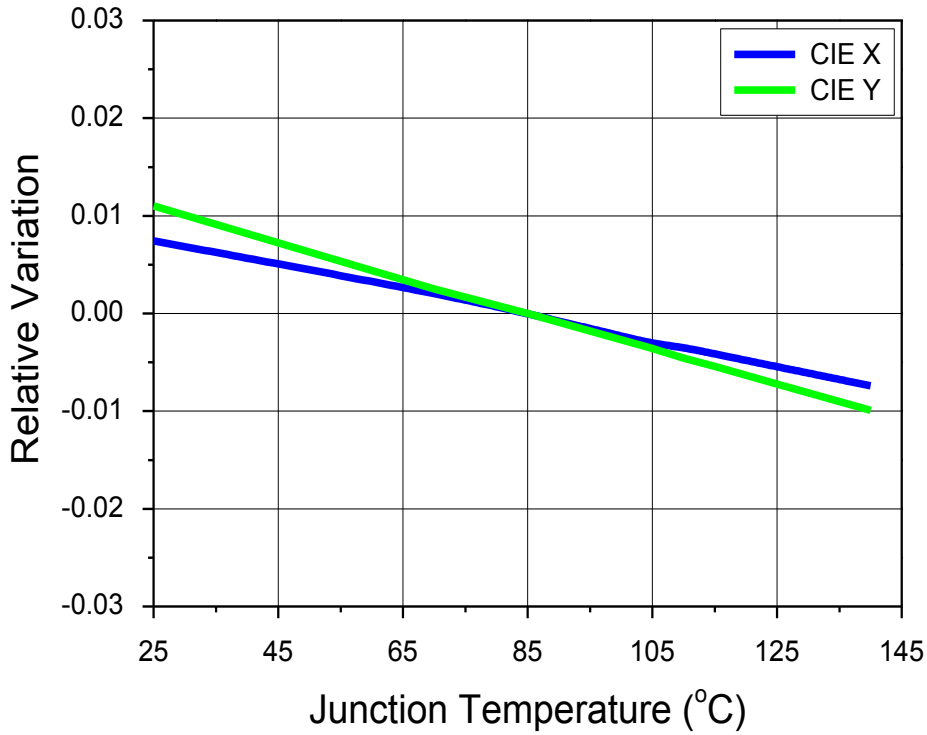
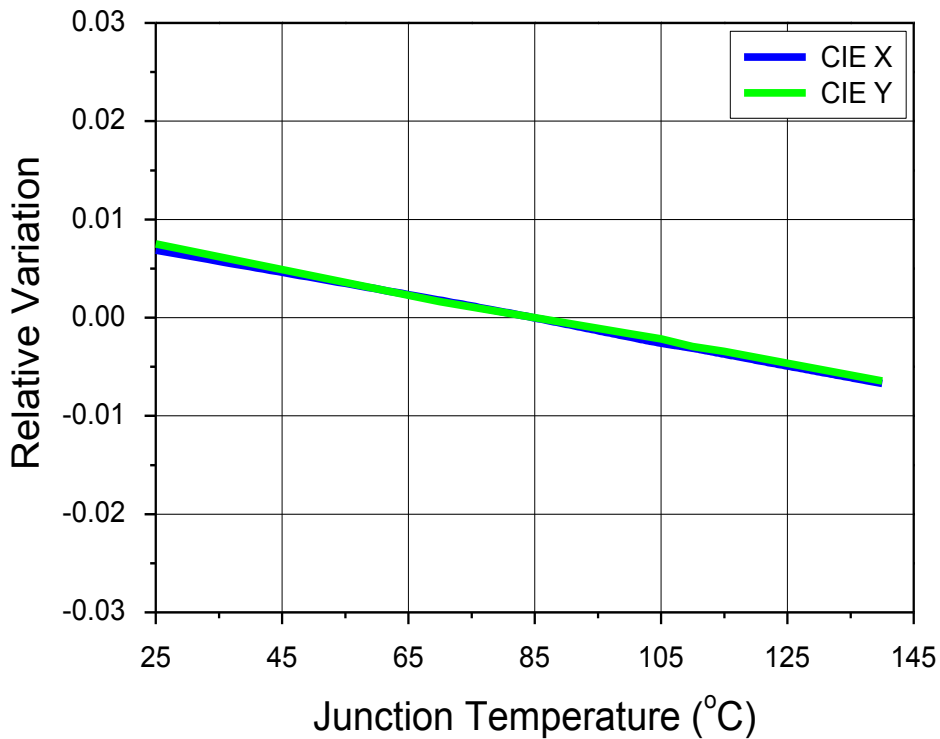

Fig 14. Junction Temperature vs. CIE x,y Shift, $I_f=0.24A$ (CRI80, Neutral White)



Characteristics Graph

Fig 15. Junction Temperature vs. CIE x,y Shift, $I_f=0.24A$ (CRI80, Warm White)

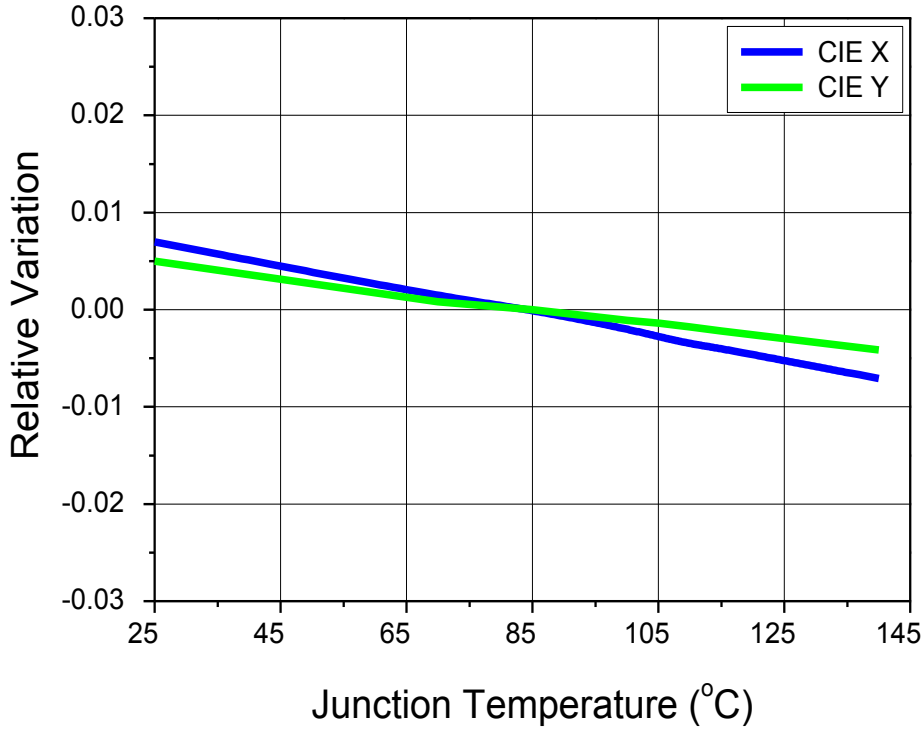
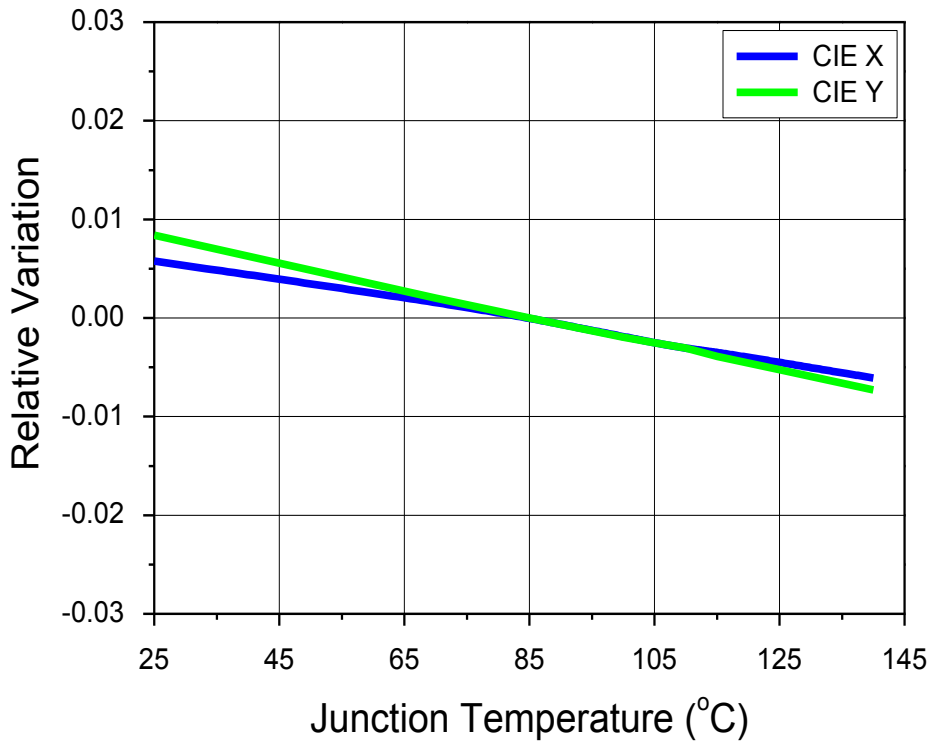

Fig 16. Junction Temperature vs. CIE x,y Shift, $I_f=0.24A$ (CRI90, Neutral White)



Color Bin Structure

Table 5. Bin Code description, $T_j=85^{\circ}\text{C}$, $I_f=0.24\text{A}$

| Part Number | Luminous Flux (lm) | | | Color Chromaticity | | Typical Forward Voltage (V) | | | CRI | |
|-------------|--------------------|------|------|--------------------|----------|-----------------------------|------|------|----------|-----|
| | Bin Code | Min. | Typ. | Bin Code | Typ. CCT | Bin Code | Min. | Max. | Bin Code | Min |
| SAW814K2AB | D0 | 4050 | 4280 | AE3 | 6500K | V | 113 | 120 | 8 | 80 |
| | D0 | 4110 | 4350 | BE3 | 5700K | V | 113 | 120 | 8 | 80 |
| | D0 | 4150 | 4390 | CE3 | 5000K | V | 113 | 120 | 8 | 80 |
| | D0 | 4200 | 4450 | EE3 | 4000K | V | 113 | 120 | 8 | 80 |
| | D0 | 4080 | 4320 | FE3 | 3500K | V | 113 | 120 | 8 | 80 |
| | D0 | 3990 | 4230 | GE3 | 3000K | V | 113 | 120 | 8 | 80 |
| | D0 | 3870 | 4090 | HE3 | 2700K | V | 113 | 120 | 8 | 80 |
| SAW914K2AB | D0 | 3630 | 3840 | EE2 EE3 | 4000K | V | 113 | 120 | 9 | 90 |
| | D0 | 3530 | 3740 | FE2 FE3 | 3500K | V | 113 | 120 | 9 | 90 |
| | D0 | 3450 | 3650 | GE2 GE3 | 3000K | V | 113 | 120 | 9 | 90 |
| | D0 | 3300 | 3490 | HE2 HE3 | 2700K | V | 113 | 120 | 9 | 90 |

Color Bin Structure

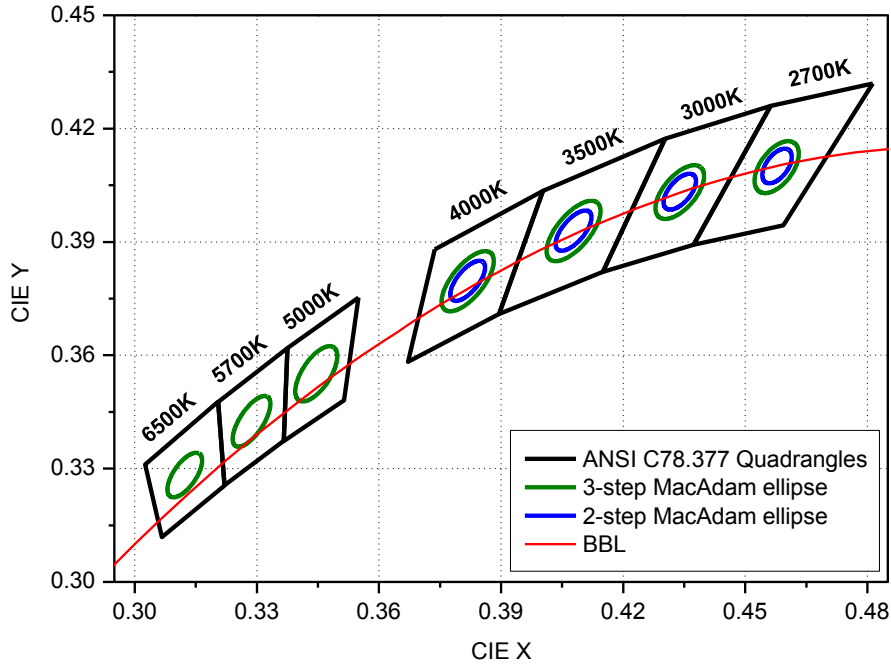
CIE Chromaticity Diagram, $T_j=85^\circ\text{C}$, $I_F=240\text{mA}$

Table 6. 2-step/3-step MacAdam ellipse color bin definitions

| Color Region | CCT (K) | Center Point | | Major Axis (a) | Minor Axis (b) | Rotation Angle (θ) |
|------------------------|---------|--------------|--------|----------------|----------------|-----------------------------|
| | | CIE x | CIE y | | | |
| 3-step MacAdam ellipse | 6500 | 0.3123 | 0.3283 | 0.00669 | 0.00285 | 58.38 |
| | 5700 | 0.3287 | 0.3425 | 0.00760 | 0.00296 | 59.46 |
| | 5000 | 0.3446 | 0.3551 | 0.00822 | 0.00354 | 59.62 |
| | 4000 | 0.3818 | 0.3797 | 0.00939 | 0.00402 | 54.00 |
| | 3500 | 0.4078 | 0.393 | 0.00951 | 0.00417 | 52.97 |
| | 3000 | 0.4339 | 0.4033 | 0.00834 | 0.00408 | 53.17 |
| | 2700 | 0.4578 | 0.4101 | 0.00774 | 0.00411 | 57.28 |
| 2-step MacAdam ellipse | 4000 | 0.3818 | 0.3797 | 0.00626 | 0.00268 | 54.00 |
| | 3500 | 0.4078 | 0.393 | 0.00634 | 0.00278 | 52.97 |
| | 3000 | 0.4339 | 0.4033 | 0.00556 | 0.00272 | 53.17 |
| | 2700 | 0.4578 | 0.4101 | 0.00516 | 0.00274 | 57.28 |

Notes :

- (1) The chromaticity center refers to ANSI C78.377:2015.
- (2) (a), (b), and (θ) indicate the major axis length, the minor axis length, and the rotation angle from the X axis of the ellipse bin, respectively.
- (3) It's possible to deliver 2-step bin up to 4000K.

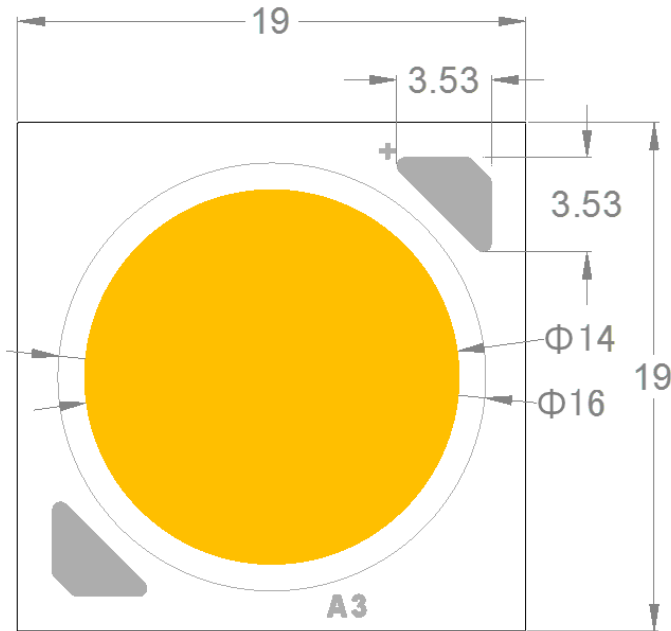
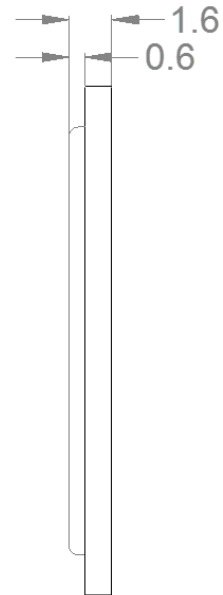
Mechanical Dimensions

< Top View >

< Side View >

Notes :

- (1) All dimensions are in millimeters.
- (2) Scale : none
- (3) Undefined tolerance is ± 0.3 mm

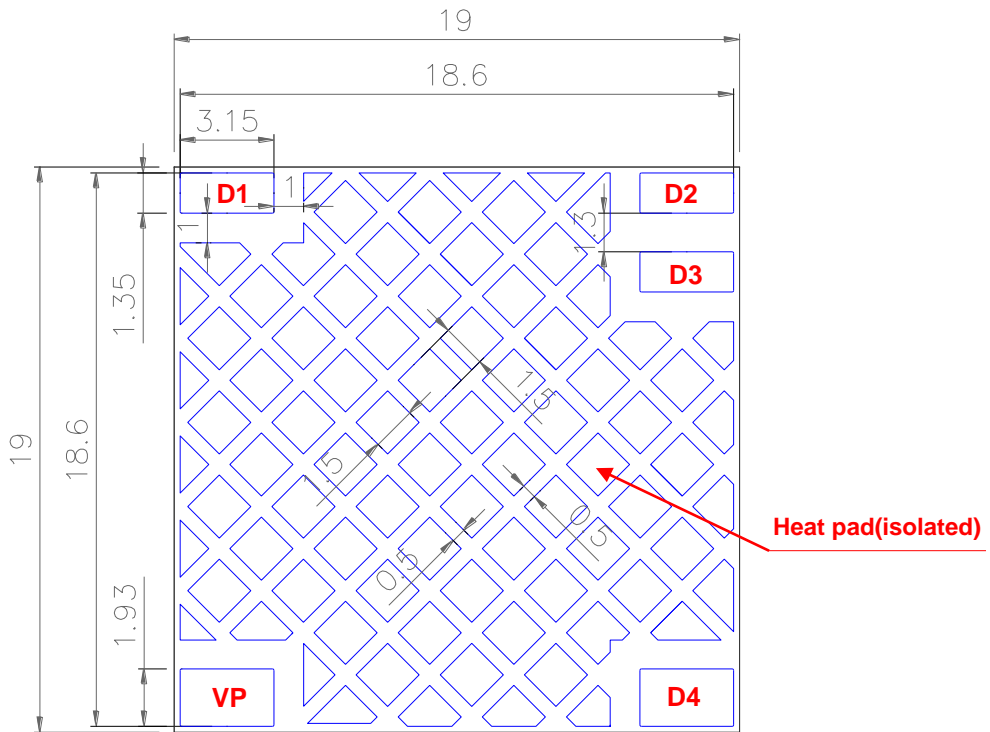
Mechanical Dimensions

< Bottom View >



< Inner Circuit Diagram >

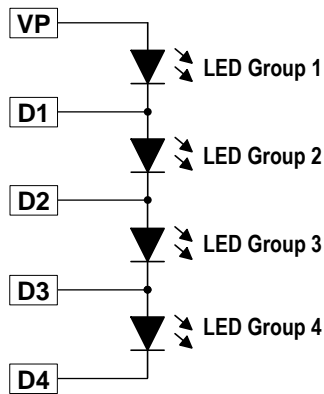

Notes :

- (1) All dimensions are in millimeters.
- (2) Scale : none
- (3) Undefined tolerance is $\pm 0.2\text{mm}$
- (4) Inner Circuit Diagram : All pins(VP,D1,D2,D3,D4) are connected with Acrich IC.

Recommended Solder Pad

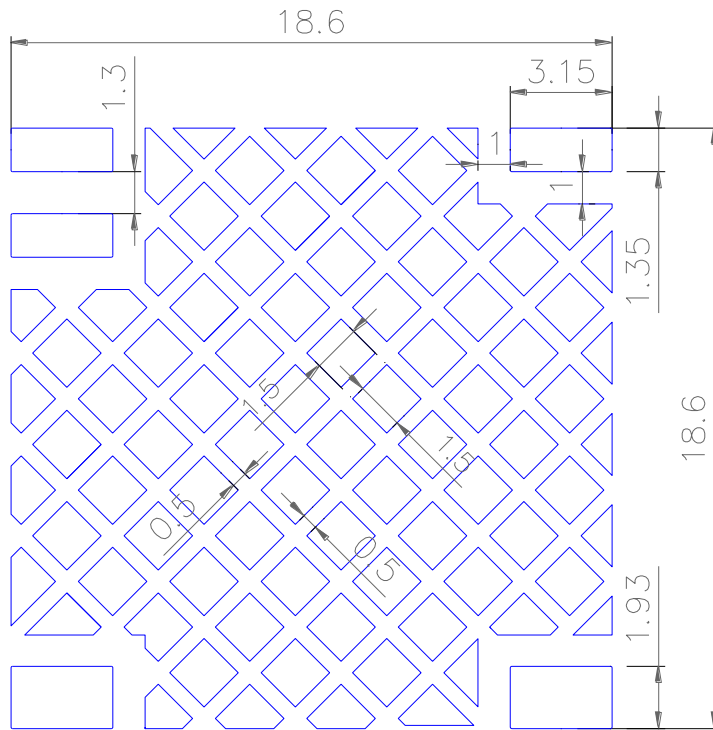

Notes :

- (1) All dimensions are in millimeters.
- (2) Scale : none
- (2) Undefined tolerance is $\pm 0.2\text{mm}$
- (3) It recommended that metal mask is designed to be under 80% of dimension of solder pad.

Reflow Soldering Characteristics

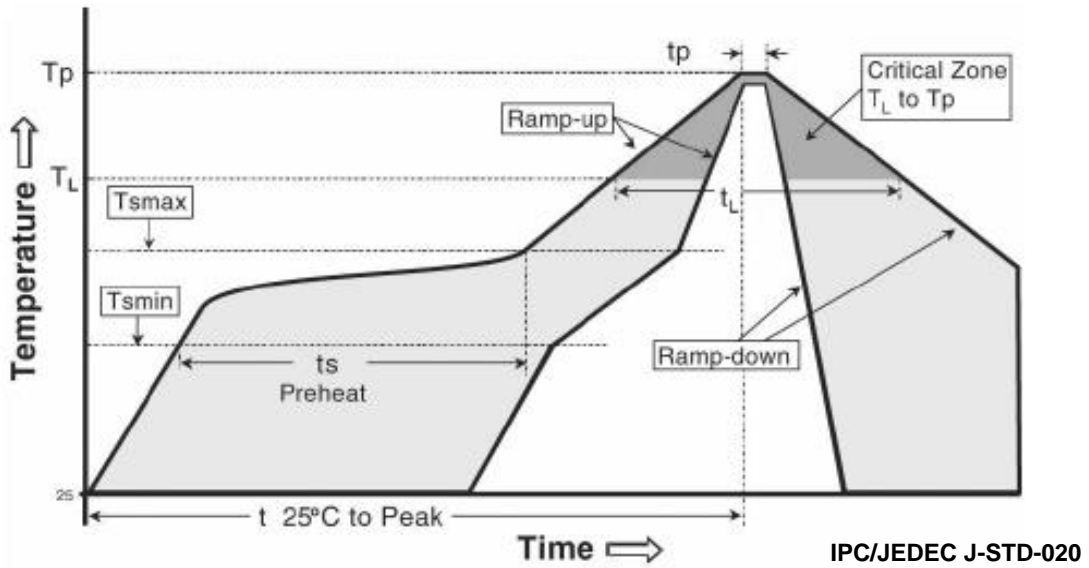

| Profile Feature | Sn-Pb Eutectic Assembly | Pb-Free Assembly |
|--|------------------------------------|------------------------------------|
| Average ramp-up rate (T _{max} to T _p) | 3° C/second max. | 3° C/second max. |
| Preheat - Temperature Min (T _{min}) - Temperature Max (T _{max}) - Time (T _{min} to T _{max}) (ts) | 100 °C 150 °C 60-120 seconds | 150 °C 200 °C 60-180 seconds |
| Time maintained above: - Temperature (T _L) - Time (t _L) | 183 °C 60-150 seconds | 217 °C 60-150 seconds |
| Peak Temperature (T _p) | 215°C | 260°C |
| Time within 5°C of actual Peak Temperature (tp) ² | 10-30 seconds | 20-40 seconds |
| Ramp-down Rate | 6 °C/second max. | 6 °C/second max. |
| Time 25°C to Peak Temperature | 6 minutes max. | 8 minutes max. |

Notes :

- (1) Reflow soldering is recommended not to be done more than two times. In the case of more than 24 hours passed soldering after first, LEDs will be damaged.
- (2) Repairs should not be done after the LEDs have been soldered. When repair is unavoidable, suitable tools must be used.
- (3) Die slug is to be soldered.
- (4) When soldering, do not put stress on the LEDs during heating.
- (5) After soldering, do not warp the circuit board.

Packaging Specification

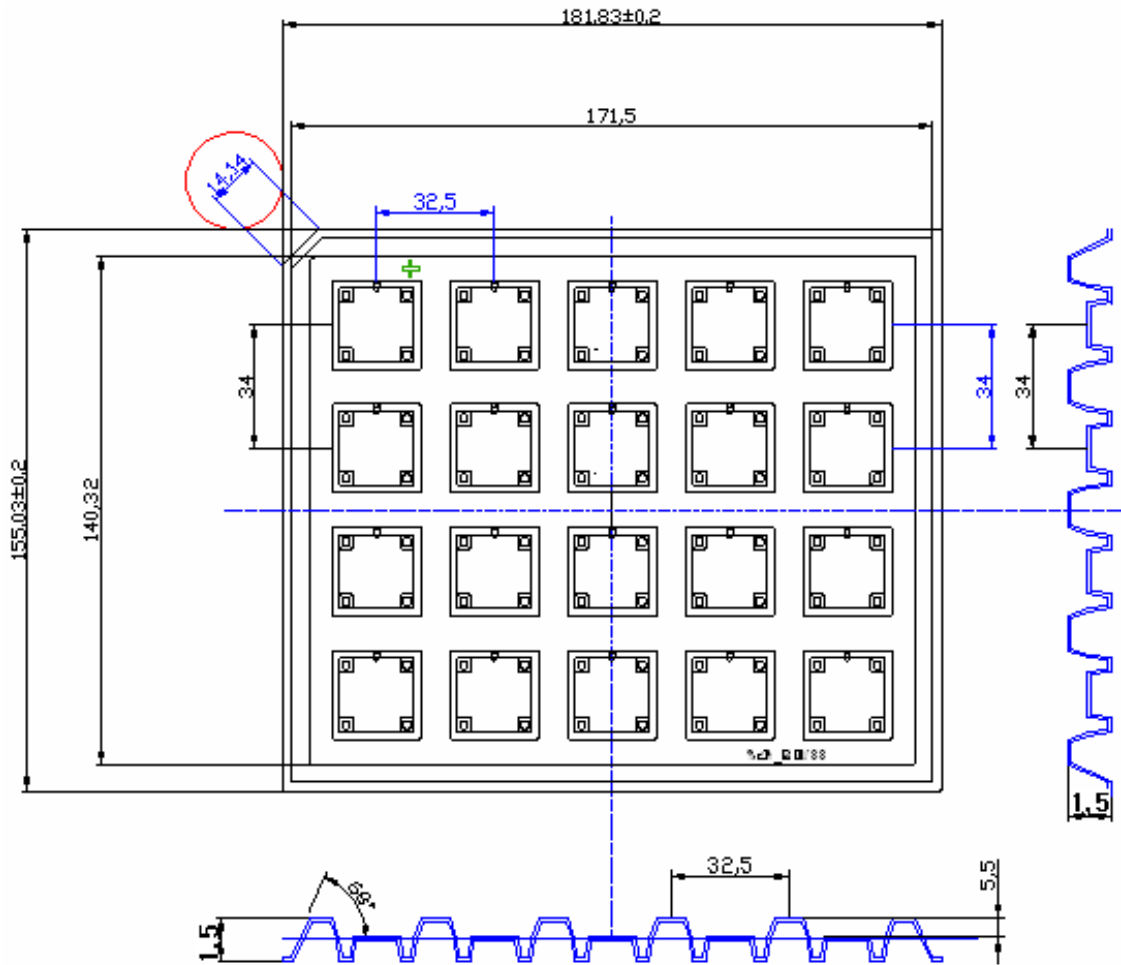
Notes :

- (1) Quantity : 20pcs/Tray
- (2) All dimensions are in millimeters (tolerance : ±0.3)
- (3) Scale none

Packaging Specification

Aluminum Bag

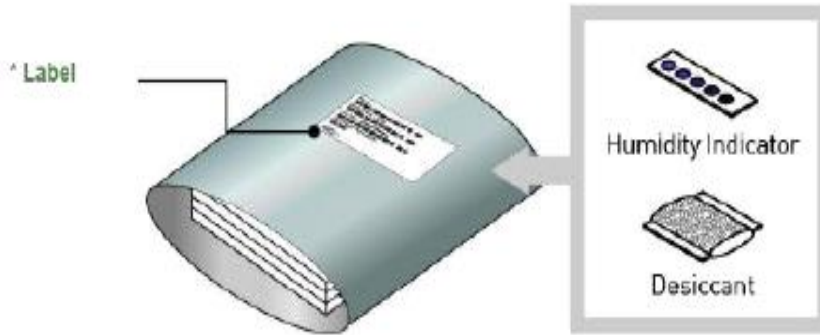

Outer Box

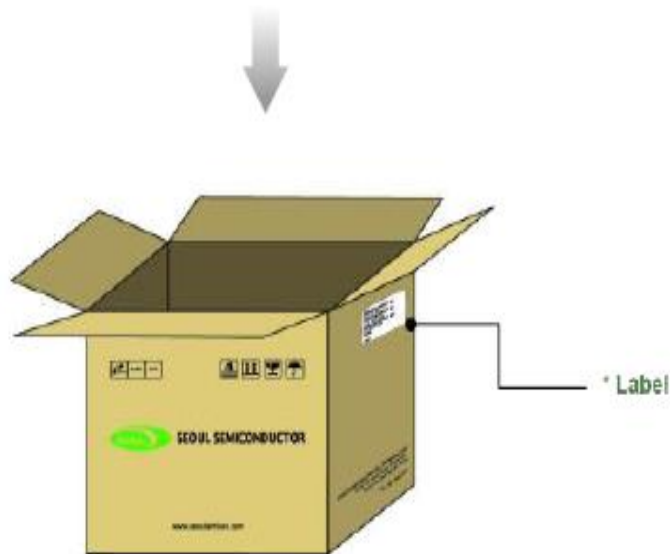



Notes :

- (1) Heat Sealed after packing (Use Zipper Bag)
- (2) Quantity : 1Tray(20pcs) /Bag
- (3) Smallest packing quantity : 3Bags(60pcs) / small box

Product Nomenclature

RANK : Z₁Z₁Z₂Z₂Z₃Z₄

QUANTITY : 20

LOT NUMBER : Y₁Y₂Y₃Y₄Y₅Y₆Y₇Y₈Y₉Y₁₀ – Y₁₁Y₁₂Y₁₃Y₁₄Y₁₅Y₁₆Y₁₇

SSC PART NUMBER : X₁X₂X₃X₄X₅X₆X₇X₈X₉





Table 7. Part Numbering System : X₁X₂X₃X₄X₅X₆X₇X₈X₉X₁₀

| Part Number Code | Description | Part Number | Value |
|-------------------------------|---------------------|-------------|----------|
| X ₁ | Company | S | |
| X ₂ | Package series | A | |
| X ₃ X ₄ | Color Specification | W8 | CRI 80 |
| | | W9 | CRI 90 |
| X ₅ X ₆ | LES size | 14 | |
| X ₇ | Chip Array | K | Series |
| X ₈ | Chip Array | 2 | Parallel |
| X ₉ | Revision number | A | |
| X ₁₀ | Voltage | B | 120V |

Table 8. Lot Numbering System : Y₁Y₂Y₃Y₄Y₅Y₆Y₈Y₉Y₁₀ – Y₁₁Y₁₂Y₁₃Y₁₄Y₁₅Y₁₆Y₁₇

| Lot Number Code | Description |
|---|---------------------|
| Y ₁ Y ₂ Y ₃ Y ₄ Y ₅ | Date of box packing |
| Y ₆ Y ₇ Y ₈ Y ₉ Y ₁₀ | Date of label order |
| Y ₁₁ Y ₁₂ Y ₁₃ Y ₁₄ Y ₁₅ Y ₁₆ Y ₁₇ | Item code |

Handling of Silicone Resin for LEDs

- (1) During processing, mechanical stress on the surface should be minimized as much as possible. Sharp objects of all types should not be used to pierce the sealing compound.



- (2) In general, LEDs should only be handled from the side. By the way, this also applies to LEDs without a silicone sealant, since the surface can also become scratched.

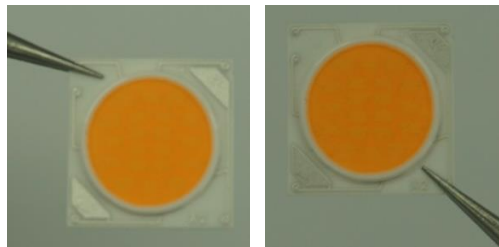

- (3) Silicone differs from materials conventionally used for the manufacturing of LEDs. These conditions must be considered during the handling of such devices. Compared to standard encapsulants, silicone is generally softer, and the surface is more likely to attract dust. As mentioned previously, the increased sensitivity to dust requires special care during processing. In cases where a minimal level of dirt and dust particles cannot be guaranteed, a suitable cleaning solution must be applied to the surface after the soldering of wire.
- (4) Seoul Semiconductor suggests using isopropyl alcohol for cleaning. In case other solvents are used, it must be assured that these solvents do not dissolve the package or resin. Ultrasonic cleaning is not recommended. Ultrasonic cleaning may cause damage to the LED.
- (5) Please do not mold this product into another resin (epoxy, urethane, etc) and do not handle this product with acid or sulfur material in sealed space.
- (6) Avoid leaving fingerprints on silicone resin parts.

Precaution for Use

(1) Storage

To avoid the moisture penetration, we recommend storing LEDs in a dry box with a desiccant .

The recommended storage temperature range is 5°C to 30°C and a maximum humidity of RH50%.

(2) Use Precaution after Opening the Packaging

Use SMT techniques properly when you solder the LED as separation of the lens may affect the light output efficiency.

Pay attention to the following:

a. Recommend conditions after opening the package

- Sealing

- Temperature : 5 ~ 30°C Humidity : less than RH60%

b. If the package has been opened more than 4 week(MSL_2a) or the color of the desiccant changes, components should be dried for 10-24hr at 65±5°C

c. After package has been opened, It's possible to change color of top electrode depending on environment. But discoloration of top electrode does not affect on device performance.

(3) Do not apply mechanical force or excess vibration during the cooling process to normal temperature after soldering.

(4) Do not rapidly cool device after soldering.

(5) Components should not be mounted on warped (non coplanar) portion of PCB.

(6) Radioactive exposure is not considered for the products listed here in.

(7) Gallium arsenide is used in some of the products listed in this publication. These products are dangerous if they are burned or shredded in the process of disposal. It is also dangerous to drink the liquid or inhale the gas generated by such products when chemically disposed of.

(8) This device should not be used in any type of fluid such as water, oil, organic solvent and etc. When washing is required, IPA (Isopropyl Alcohol) should be used.

(9) When the LEDs are in operation the maximum current should be decided after measuring the package temperature.

(10) LEDs must be stored in a clean environment. We recommend LEDs store in nitrogen-filled container.

Precaution for Use

- (11) The appearance and specifications of the product may be modified for improvement without notice.
- (12) Long time exposure of sunlight or occasional UV exposure will cause lens discoloration.
- (13) Attaching LEDs, do not use adhesive that outgas organic vapor.
- (14) The driving circuit must be designed to allow forward voltage only when it is ON or OFF. If the reverse voltage is applied to LED, migration can be generated resulting in LED damage.
- (15) Please do not touch any of the circuit board, components or terminals with bare hands or metal while circuit is electrically active.
- (16) VOCs (Volatile organic compounds) emitted from materials used in the construction of fixtures can penetrate silicone encapsulants of LEDs and discolor when exposed to heat and photonic energy. The result can be a significant loss of light output from the fixture. Knowledge of the properties of the materials selected to be used in the construction of fixtures can help prevent these issues.
- (17) LEDs are sensitive to Electro-Static Discharge (ESD) and Electrical Over Stress (EOS). Below is a list of suggestions that Seoul Semiconductor purposes to minimize these effects.

a. ESD (Electro Static Discharge)

Electrostatic discharge (ESD) is defined as the release of static electricity when two objects come into contact. While most ESD events are considered harmless, it can be an expensive problem in many industrial environments during production and storage. The damage from ESD to LEDs may cause the product to demonstrate unusual characteristics such as:

- Increase in reverse leakage current lowered turn-on voltage
- Abnormal emissions from the LED at low current

The following recommendations are suggested to help minimize the potential for an ESD event.

One or more recommended work area suggestions:

- Ionizing fan setup
- ESD table/shelf mat made of conductive materials
- ESD safe storage containers

One or more personnel suggestion options:

- Antistatic wrist-strap
- Antistatic material shoes
- Antistatic clothes

Environmental controls:

- Humidity control (ESD gets worse in a dry environment)

Precaution for Use

b. EOS (Electrical Over Stress)

Electrical Over-Stress (EOS) is defined as damage that may occur when an electronic device is subjected to a current or voltage that is beyond the maximum specification limits of the device.

The effects from an EOS event can be noticed through product performance like:

- Changes to the performance of the LED package
(If the damage is around the bond pad area and since the package is completely encapsulated the package may turn on but flicker show severe performance degradation.)
- Changes to the light output of the luminaire from component failure
- Components on the board not operating at determined drive power

Failure of performance from entire fixture due to changes in circuit voltage and current across total circuit causing trickle down failures. It is impossible to predict the failure mode of every LED exposed to electrical overstress as the failure modes have been investigated to vary, but there are some common signs that will indicate an EOS event has occurred:

- Damaged may be noticed to the bond wires (appearing similar to a blown fuse)
- Damage to the bond pads located on the emission surface of the LED package
(shadowing can be noticed around the bond pads while viewing through a microscope)
- Anomalies noticed in the encapsulation and phosphor around the bond wires.
- This damage usually appears due to the thermal stress produced during the EOS event.

c. To help minimize the damage from an EOS event Seoul Semiconductor recommends utilizing:

- A surge protection circuit
- An appropriately rated over voltage protection device
- A current limiting device