

PRODUCT PROFILE

CURRENT TRANSFORMER

MODEL 1411-126

Application

Metering.

Frequency

50-400 Hz.

Insulation Level

0.6 kV, 10 kV BIL full wave.

- Terminals are brass studs No. 10-32 UNC with one flatwasher, and lockwasher.
- Approximate weight 5.5 lbs.

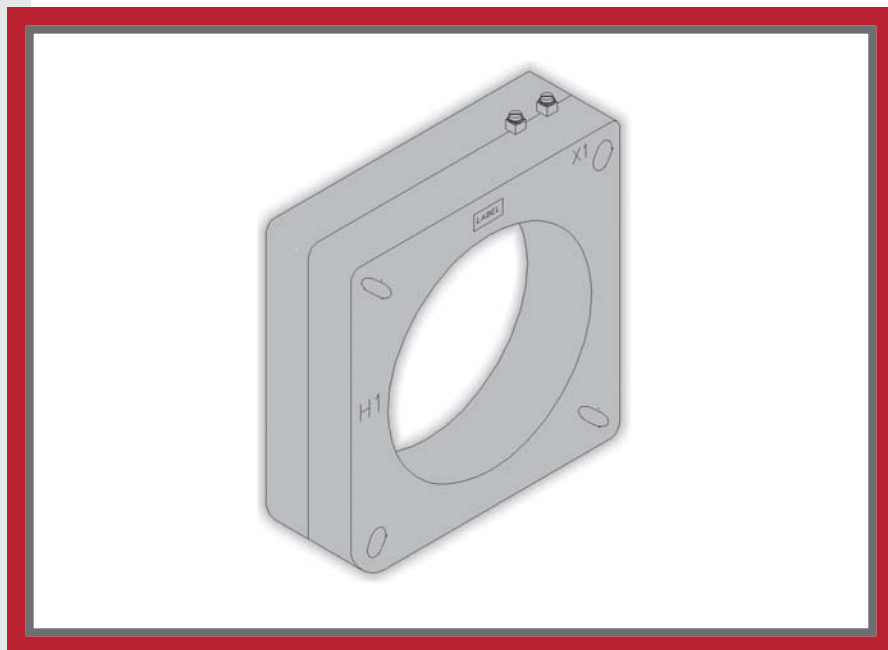

WINDOW DIAMETER 8.25"

REGULATORY AGENCY APPROVALS



Manufactured to meet the requirements of
ANSI/IEEE C57.13.

Classified by U.L. in accordance with IEC 44-1

SPECIFICATIONS

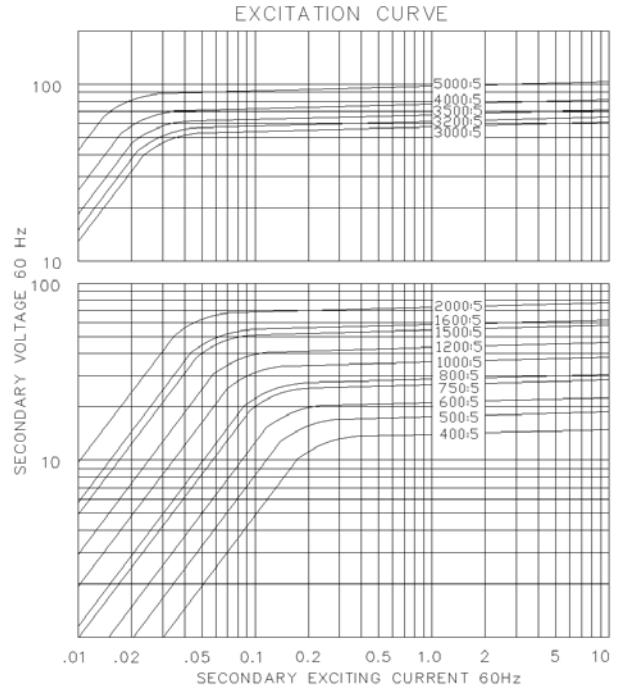
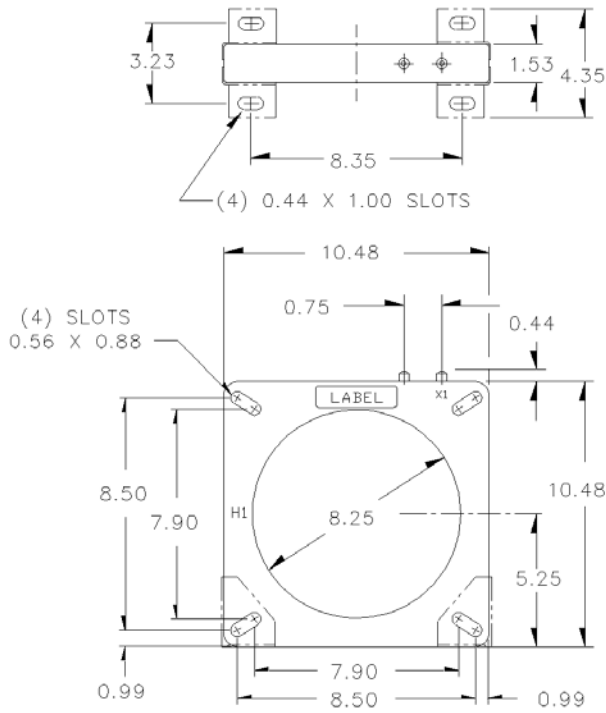

CATALOG NUMBER	CURRENT RATIO	VA FOR + 1% CLASS	ANSI METERING CLASS AT 60 Hz					SECONDARY WINDING RESISTANCE (OHMS @ 75°C)	CONTINUOUS THERMAL RATING FACTOR	
			B0.1	B0.2	B0.5	B0.9	B1.8		@30°C	@55°C
			1411 - 126 - 401	400:5	4.0	0.6	1.2		2.4	2.4
1411 - 126 - 501	500:5	7.5	0.6	0.6	1.2	2.4	2.4	0.145	2.0	2.0
1411 - 126 - 601	600:5	10.0	0.6	0.6	1.2	1.2	2.4	0.173	2.0	2.0
1411 - 126 - 801	800:5	20.0	0.3	0.3	0.6	0.6	1.2	0.231	2.0	1.5
1411 - 126 - 102	1000:5	25.0	0.3	0.3	0.6	0.6	1.2	0.289	2.0	1.5
1411 - 126 - 122	1200:5	40.0	0.3	0.3	0.3	0.6	0.6	0.347	1.5	1.33
1411 - 126 - 152	1500:5	50.0	0.3	0.3	0.3	0.3	0.6	0.434	1.5	1.0
1411 - 126 - 162	1600:5	50.0	0.3	0.3	0.3	0.3	0.6	0.462	1.5	1.0
1411 - 126 - 202	2000:5	60.0	0.3	0.3	0.3	0.3	0.3	0.578	1.33	1.0
1411 - 126 - 252	2500:5	75.0	0.3	0.3	0.3	0.3	0.3	0.904	1.0	0.8
1411 - 126 - 302	3000:5	90.0	0.3	0.3	0.3	0.3	0.3	0.722	1.33	1.0
1411 - 126 - 322	3200:5	95.0	0.3	0.3	0.3	0.3	0.3	0.770	1.33	1.0
1411 - 126 - 352	3500:5	100.0	0.3	0.3	0.3	0.3	0.3	0.842	1.0	0.8
1411 - 126 - 402	4000:5	125.0	0.3	0.3	0.3	0.3	0.3	0.962	1.0	0.8
1411 - 126 - 502	5000:5	140.0	0.3	0.3	0.3	0.3	0.3	1.203	1.0	0.8
1411 - 126 - 602	6000:5	140.0	0.3	0.3	0.3	0.3	0.3	1.278	1.0	0.8

www.rockwellautomation.com

Power, Control and Information Solutions Headquarters

Americas: Rockwell Automation, 1201 South Second Street, Milwaukee, WI 53204-2496 USA, Tel: (1) 414.382.2000, Fax: (1) 414.382.4444
 Europe/Middle East/Africa: Rockwell Automation, Vorstlaan/Boulevard du Souverain 36, 1170 Brussels, Belgium, Tel: (32) 2 663 0600, Fax: (32) 2 663 0640
 Asia Pacific: Rockwell Automation, Level 14, Core F, Cyberport 3, 100 Cyberport Road, Hong Kong, Tel: (852) 2887 4788, Fax: (852) 2508 1846