

ECG[®] Semiconductors

ECG918, ECG918M Operational Amplifier

Features

- 15MHz small signal bandwidth
- Guaranteed 50V/μs slew rate
- Maximum bias current of 250nA
- Operates from supplies of ±5V to ±20V
- Internal frequency compensation
- Input and output overload protected
- Pin compatible with general purpose op amps

ECG918 and ECG918M are precision high speed operational amplifiers designed for applications requiring wide bandwidth and high slew rate. They feature a factor of ten increase in speed over general purpose devices without sacrificing DC performance.

They also have internal unity gain frequency compensation which considerably simplifies its application since no external components are necessary for operation. However, unlike most internally compensated amplifiers, external frequency compensation may be added for optimum performance. For inverting applications, feedforward compensation will boost the slew rate to over 150V/μs and almost double the bandwidth. Overcompensation can be used with the amplifier for greater stability when maximum bandwidth is not needed. Further, a single capacitor can be added to reduce the 0.1% setting time to under 1μs.

The high speed and fast setting time of these op amps make them useful in A/D converters, oscillators, active filters, sample and hold circuits, or general purpose amplifiers.

ECG918

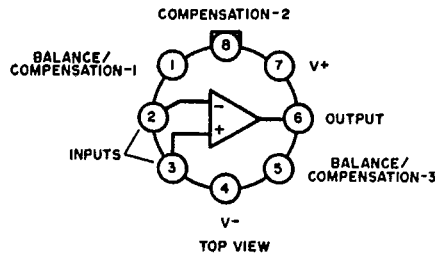
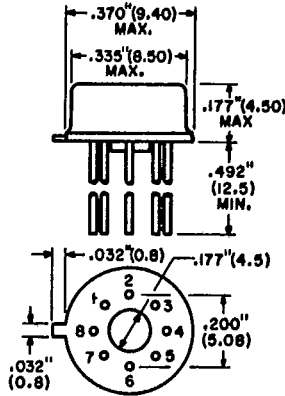

ECG918M

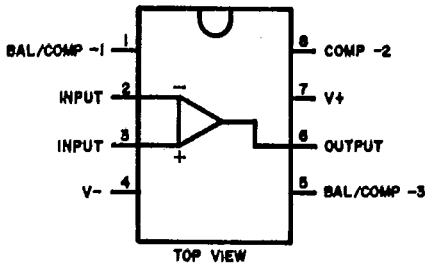
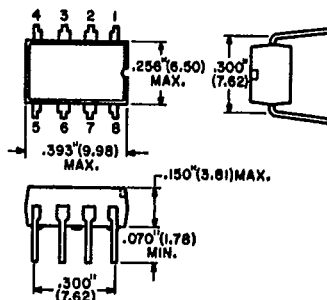

Absolute Maximum Ratings

Supply Voltage, V_S $\pm 20V$
 Power Dissipation (Note 1), P_D 500mW
 Differential Input Current (Note 2), I_{ID} $\pm 10mA$
 Input Voltage (Note 3), V_I $\pm 15V$
 Output Short-Circuit Duration, t_s Indefinite
 Operating Temperature Range, T_{opg} $0^\circ C$ to $+70^\circ C$
 Storage Temperature Range, T_{stg} $-65^\circ C$ to $+150^\circ C$
 Lead Temperature (Soldering, 10 seconds) $300^\circ C$
 Junction Temperature, T_j $110^\circ C$

Electrical Characteristics (Note: These specifications apply for $\pm 5V < V_S < \pm 20V$ and $0^\circ C < T_A < +70^\circ C$. Also, power supplies must be bypassed with 0.1 μF disc capacitors.)

Characteristic	Symbol	Test Condition	Min	Typ	Max	Unit
Input Offset Voltage	V_{IO}	$T_A = 25^\circ C$		4	10	mV
Input Offset Current	I_{IO}	$T_A = 25^\circ C$		30	200	nA
Input Bias Current	I_B	$T_A = 25^\circ C$		150	500	nA
Input Resistance	R_I	$T_A = 25^\circ C$	0.5	3		M Ω
Supply Current	I_S	$T_A = 25^\circ C$		5	10	mA
Large Signal Voltage Gain	V_{GLS}	$T_A = 25^\circ C, V_S = \pm 15V$ $V_{OUT} = \pm 10V, R_L \geq 2k\Omega$	25	200		V/mV
Slew Rate	SR	$T_A = 25^\circ C,$ $V_S = \pm 15V,$ $A_v = 1$	50	70		V/ μs
Small Signal Bandwidth	BW_{SS}	$T_A = 25^\circ C, V_S = \pm 15V$		16		MHz
Input Offset Voltage	V_{IO}				15	mV
Input Offset Current	I_{IO}				300	nA
Input Bias Current	I_B				750	nA
Large Signal Voltage Gain	V_{GLS}	$V_S = \pm 15V,$ $V_{OUT} = \pm 10V, R_L \geq 2k\Omega$	20			V/mV
Output Voltage Swing	V_{OR}	$V_S = \pm 15V, R_L = 2k\Omega$	± 12	± 13		V
Input Voltage Range	V_{IV}	$V_S = \pm 15V$	± 11.5			V
Common-Mode Rejection Ratio	CM_{RR}		70	100		dB
Supply Voltage Rejection Ratio	V_{SRR}		65	80		dB

Note 1: For operating at elevated temperatures, ECG918 must be derated based on a thermal resistance of 150 $^\circ C/W$, junction to ambient, or 45 $^\circ C/W$, junction to case. The thermal resistance of ECG918M is 100 $^\circ C/W$, junction to ambient.

Note 2: The inputs are shunted with back-to-back diodes for overvoltage protection. Therefore, excessive current will flow if a differential input voltage in excess of 1V is applied between the inputs unless some limiting resistance is used.

Note 3: For supply voltages less than $\pm 15V$, the absolute maximum input voltage is equal to the supply voltage.

Circuit Schematic

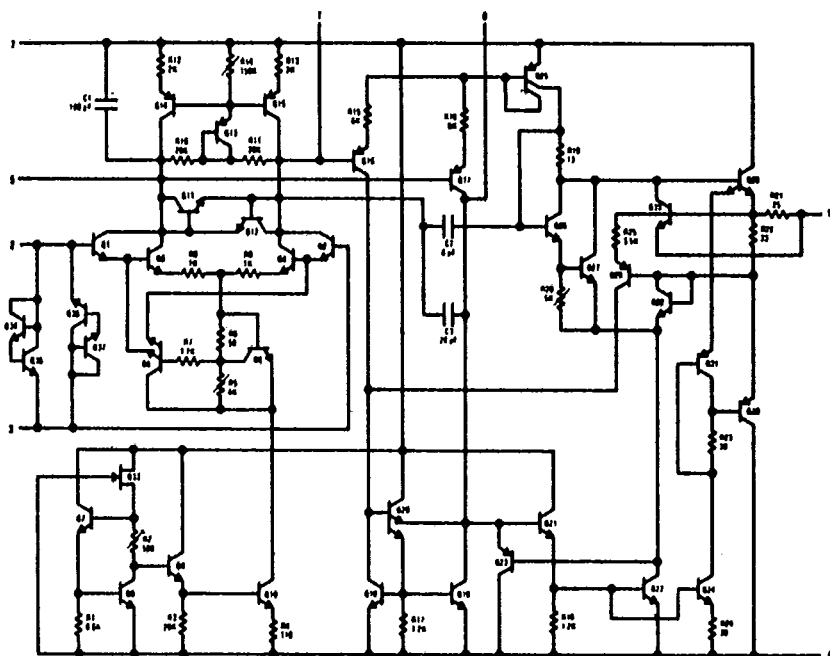

Typical Performance Characteristics

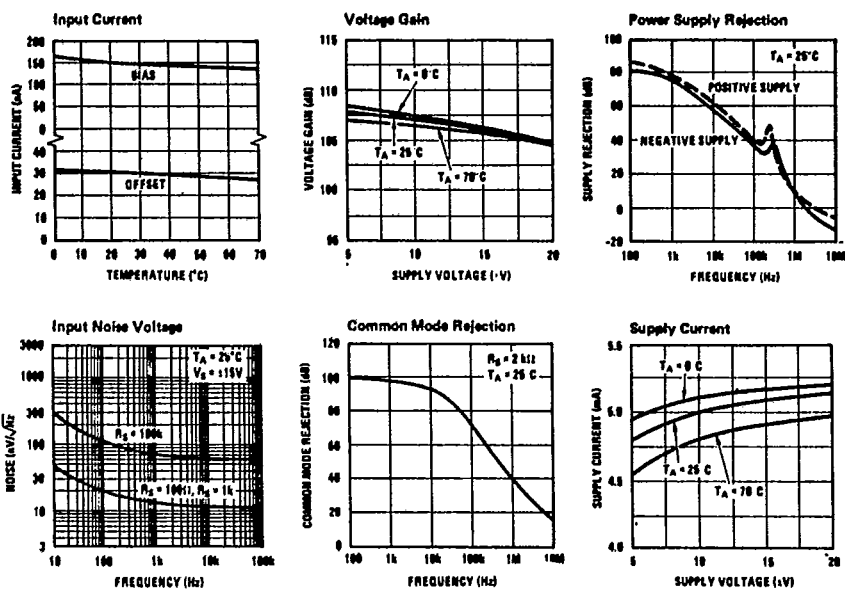

Typical Performance Characteristics (Continued)

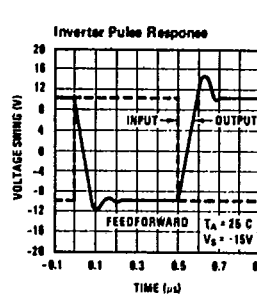
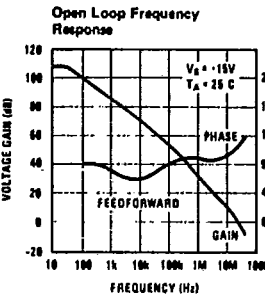
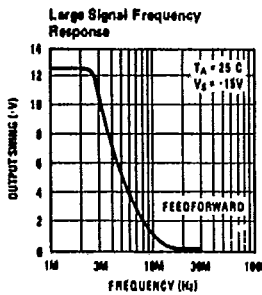
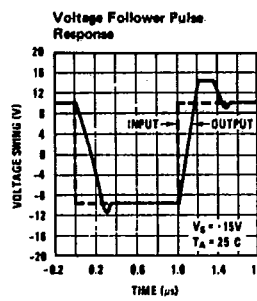
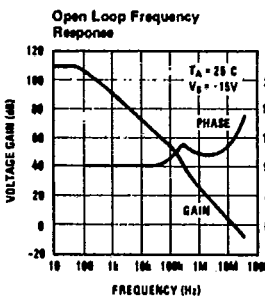
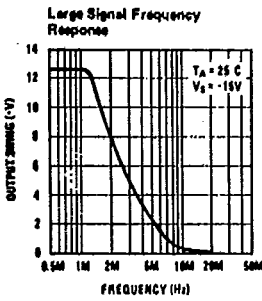
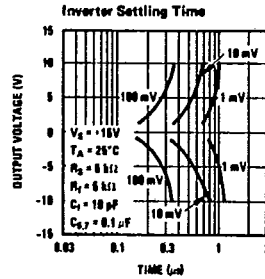
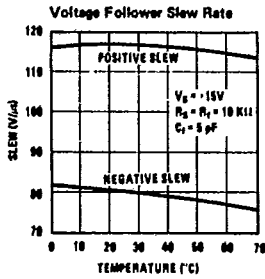
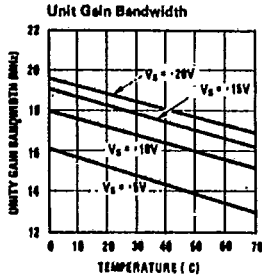
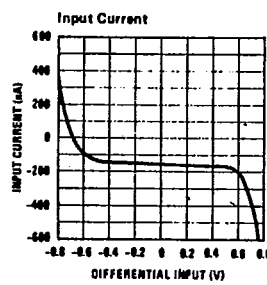
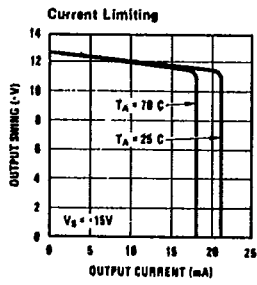
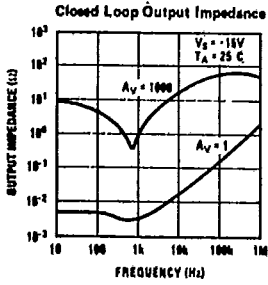

Auxiliary Circuits

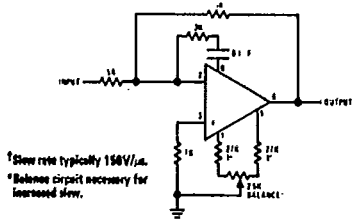

Feedforward Compensation for Greater Inverting Slew Rate†

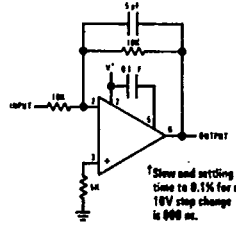

Compensation for Minimum Settling Time

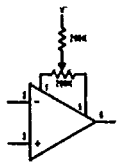

Offset Balancing

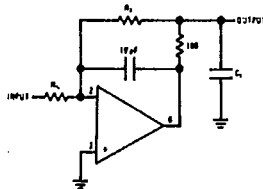

Isolating Large Capacitive Loads

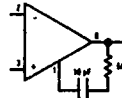

Overcompensation

Typical Applications

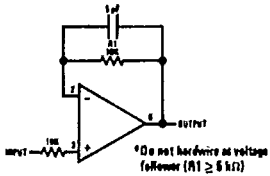

Fast Voltage Follower *

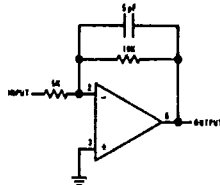

Fast Summing Amplifier

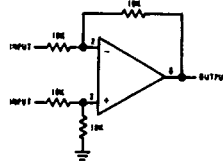

Differential Amplifier

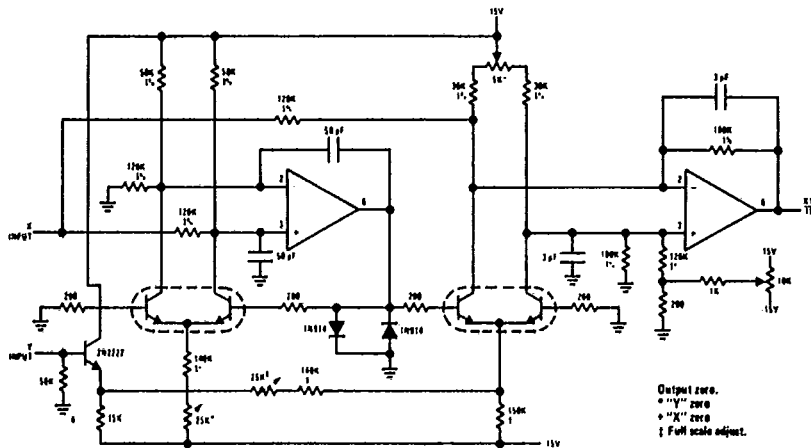

Four Quadrant Multiplier

Typical Applications (Continued)

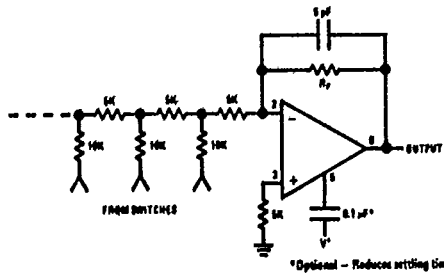

D/A Converter Using Ladder Network

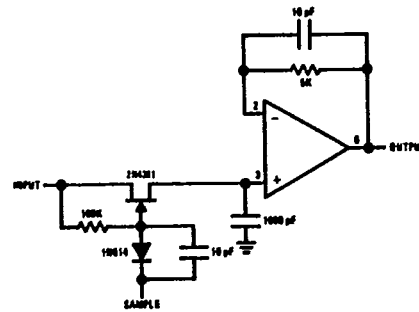

Fast Sample and Hold

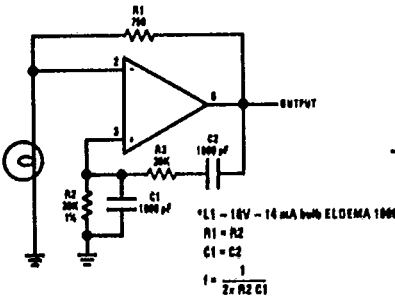

Wein Bridge Sine Wave Oscillator

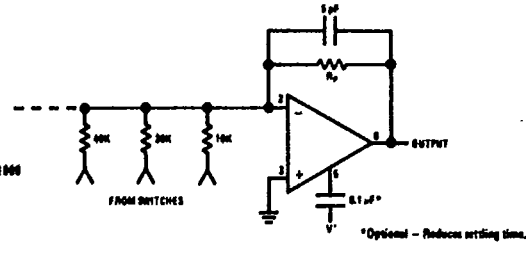

D/A Converter Using Binary Weighted Network

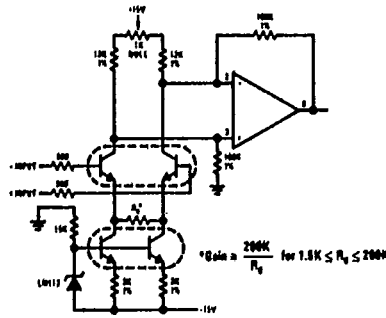

Instrumentation Amplifier

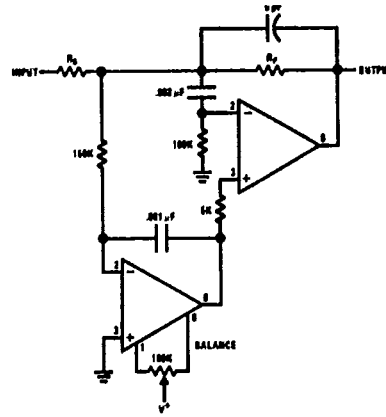

Fast Summing Amplifier with Low Input Current