

### ADVANCE INFORMATION

#### Overview Preliminary Data

The Rambus Direct RDRAM™ is a general purpose high-performance memory device suitable for use in a broad range of applications including computer memory, graphics, video, and any other application where high bandwidth and low latency are required.

The 64/72-Mbit Direct Rambus DRAMs (RDRAM®) are extremely high-speed CMOS DRAMs organized as 4M words by 16 or 18 bits. The use of Rambus Signaling Level (RSL) technology permits 600MHz or 800MHz transfer rates while using conventional system and board design technologies. Direct RDRAM devices are capable of sustained data transfers at 1.25 ns per two bytes (10ns per sixteen bytes).

The architecture of the Direct RDRAMs allows the highest sustained bandwidth for multiple, simultaneous randomly addressed memory transactions. The separate control and data buses with independent row and column control yield over 95% bus efficiency. The Direct RDRAM's sixteen banks support up to four simultaneous transactions.

System oriented features for mobile, graphics and large memory systems include power management, byte masking, and x18 organization. The two data bits in the x18 organization are general and can be used for additional storage and bandwidth or for error correction.

#### Features

- Highest sustained bandwidth per DRAM device
  - 1.6GB/s sustained data transfer rate
  - Separate control and data buses for maximized efficiency
  - Separate row and column control buses for easy scheduling and highest performance
  - 16 banks: four transactions can take place simultaneously at full bandwidth data rates
- Low latency features
  - Write buffer to reduce read latency
  - 3 precharge mechanisms for controller flexibility
  - Interleaved transactions
- Advanced power management:
  - Multiple low power states allows flexibility in power consumption versus time to transition to active state
  - Power-down self-refresh
- Organization: 1Kbyte pages and 16 banks, x 16/18
  - x18 organization allows ECC configurations or increased storage/bandwidth
  - x16 organization for low cost applications

- Uses Rambus Signaling Level (RSL) for up to 800MHz operation

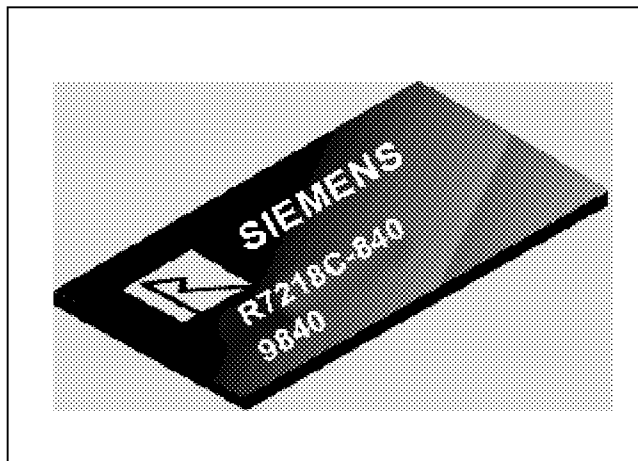

**Figure 1: Direct RDRAM CSP Package**

The 64/72-Mbit Direct RDRAMs are offered in a CSP horizontal package suitable for desktop as well as low-profile add-in card and mobile applications.

Direct RDRAMs operate from a 2.5 volt supply.

#### Part Numbers

Organization	I/O Freq. MHz	trac	Part Number
4M x 18	600	53 ns	HYB25R72180C-653
4M x 18	800	45 ns	HYB25R72180C-845
4M x 18	800	40 ns	HYB25R72180C-840
4M x 16	600	53 ns	HYB25R64160C-653
4M x 16	800	45 ns	HYB25R64160C-845
4M x 16	800	40 ns	HYB25R64160C-840

**Pinouts and Definitions**

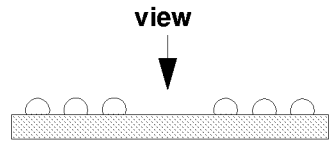
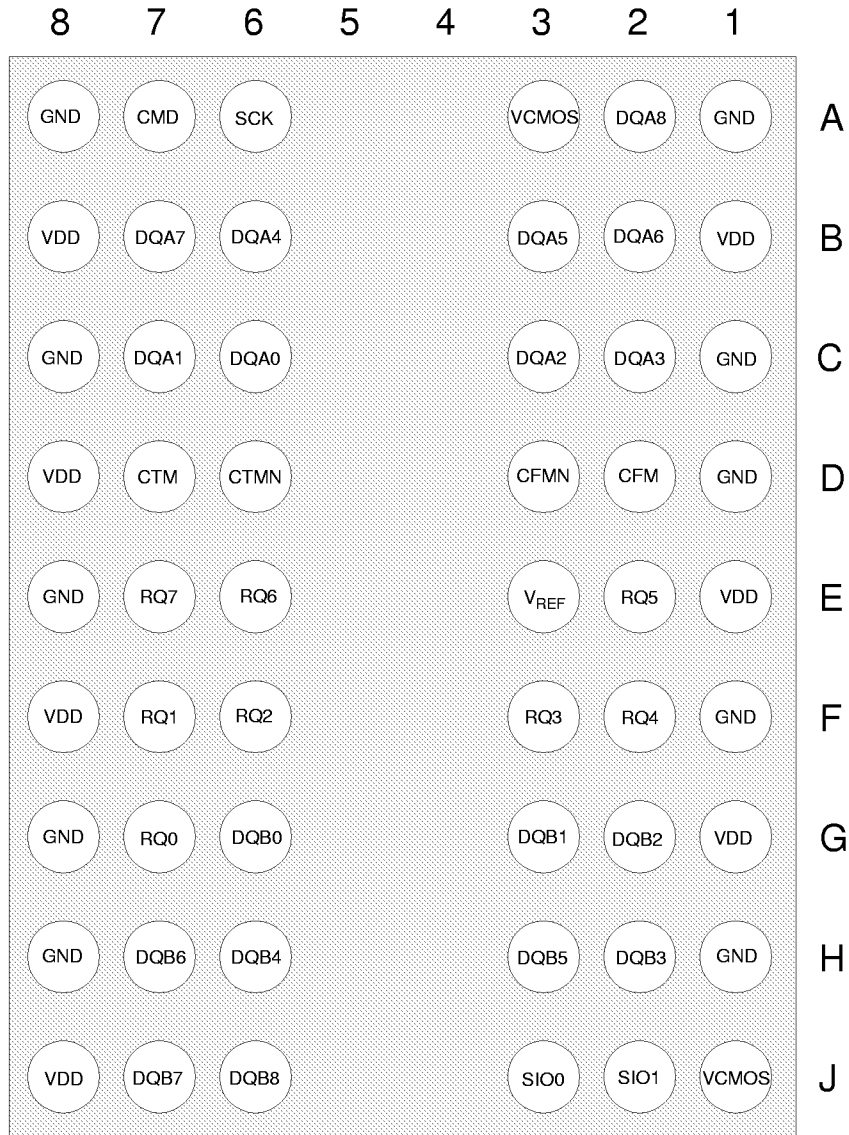

**Figure 2: Pinout Definitions**

**Table 1: Pin Description**

Signal	I/O	Type	# Pins edge	# Pins center	Description
SIO1,SIO0	I/O	CMOS	2	2	Serial input/output. Pins for reading from and writing to the control registers using a serial access protocol. Also used for power management.
CMD	I	CMOS	1	1	Command input. Pins used in conjunction with SIO0 and SIO1 for reading from and writing to the control registers. Also used for power management.
SCK	I	CMOS	1	1	Serial clock input. Clock source used for reading from and writing to the control registers
V <sub>DD</sub>			14	6	Supply voltage for the RDRAM core and interface logic.
V <sub>DDa</sub>			2	1	Supply voltage for the RDRAM analog circuitry.
V <sub>CMOS</sub>			2	2	Supply voltage for CMOS input/output pins.
GND			19	9	Ground reference for RDRAM core and interface.
GNDa			2	1	Ground reference for RDRAM analog circuitry.
DQA8..DQA0	I/O	RSL	9	9	Data byte A. Nine pins which carry a byte of read or write data between the Channel and the RDRAM. DQA8 is not used by RDRAMs with a x16 organization.
CFM	I	RSL	1	1	Clock from master. Interface clock used for receiving RSL signals from the Channel. Positive polarity.
CFMN	I	RSL	1	1	Clock from master. Interface clock used for receiving RSL signals from the Channel. Negative polarity
V <sub>REF</sub>			1	1	Logic threshold reference voltage for RSL signals
CTMN	I	RSL	1	1	Clock to master. Interface clock used for transmitting RSL signals to the Channel. Negative polarity.
CTM	I	RSL	1	1	Clock to master. Interface clock used for transmitting RSL signals to the Channel. Positive polarity.
RQ7..RQ5 or ROW2..ROW0	I	RSL	3	3	Row access control. Three pins containing control and address information for row accesses.
RQ4..RQ0 or COL4..COL0	I	RSL	5	5	Column access control. Five pins containing control and address information for column accesses.
DQB8..DQB0	I/O	RSL	9	9	Data byte B. Nine pins which carry a byte of read or write data between the Channel and the RDRAM. DQB8 is not used by RDRAMs with a x16 organization.
Total pin count per package			74	54	

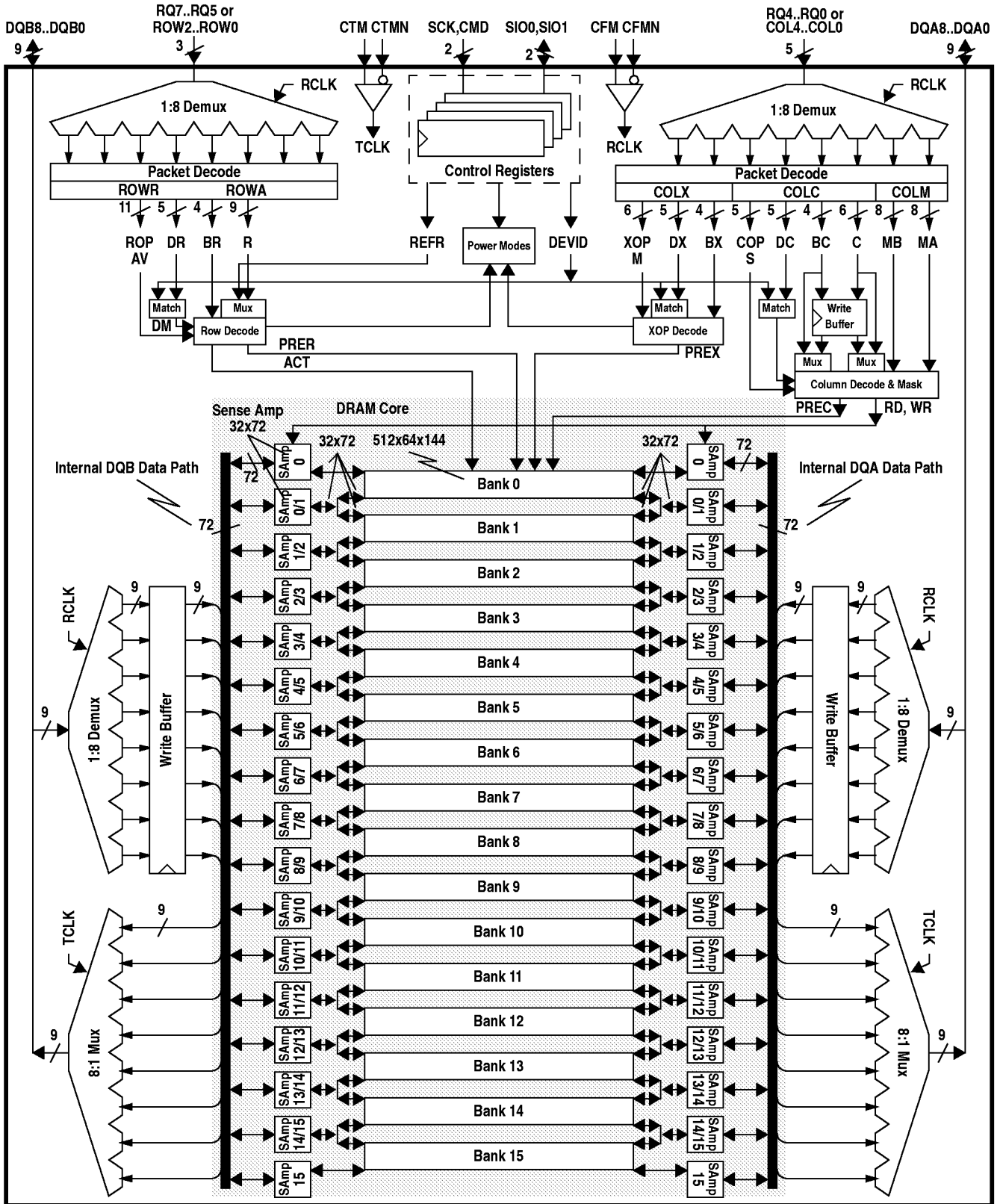

Figure 3: 64/74Mbit Direct RDRAM Block Diagram

## General Description

Figure 2 is a block diagram of the 64/72Mbit Direct RDRAM. It consists of two major blocks: a "core" block built from banks and sense amps similar to those found in other types of DRAM, and a Direct Rambus interface block which permits an external controller to access this core at up to 1.6GB/s.

**Control Registers:** The CMD, SCK, SIO0, and SIO1 pins appear in the upper center of Figure 2. They are used to write and read a block of control registers. These registers supply the RDRAM configuration information to a controller and they select the operating modes of the device. The nine bit REFR value is used for tracking the last refreshed row. Most importantly, the five bit DEVID specifies the device address of the RDRAM on the Channel.

**Clocking:** The CTM and CTMN pins (Clock-To-Master) generate TCLK (Transmit Clock), the internal clock used to transmit read data. The CFM and CFMN pins (Clock-From-Master) generate RCLK (Receive Clock), the internal clock signal used to receive write data and to receive the ROW and COL pins.

**DQA,DQB Pins:** These 18 pins carry read (Q) and write (D) data across the Channel. They are multiplexed/de-multiplexed from/to two 72-bit data paths (running at one-eighth the data frequency) inside the RDRAM.

**Banks:** The 8Mbyte core of the RDRAM is divided into sixteen 0.5Mbyte banks, each organized as 512 rows, with each row containing 64 dualocts, and each dualoct containing 16 bytes. A dualoct is the smallest unit of data that can be addressed.

**Sense Amps:** The RDRAM contains 17 sense amps. Each sense amp consists of 512 bytes of fast storage (256 for DQA and 256 for DQB) and can hold one-half of one row of one bank of the RDRAM. The sense amp may hold any of the 512 half-rows of an associated bank. However, each sense amp is shared between two adjacent banks of the RDRAM (except for numbers 0 and 15). This introduces the restriction that adjacent banks may not be simultaneously accessed.

**RQ Pins:** These pins carry control and address information. They are broken into two groups. RQ7..RQ5 are also called ROW2..ROW0, and are used primarily for controlling row accesses. RQ4..RQ0 are also called COL4..COL0, and are used primarily for controlling column accesses.

**ROW Pins:** The principle use of these three pins is to manage the transfer of data between the banks and the sense amps of the RDRAM. These pins are de-multiplexed into a 24-bit ROWA (row-activate) or ROWR (row-operation) packet.

**COL Pins:** The principle use of these five pins is to manage the transfer of data between the DQA/DQB pins and the sense amps of the RDRAM. These pins are de-multiplexed into a 23-bit COLC (column-operation) packet and either a 17-bit COLM (mask) packet or a 17-bit COLX (extended-operation) packet.

**ACT Command:** An ACT (activate) command from an ROWA packet causes one of the 512 rows of the selected bank to be loaded to its associated sense amps (two 256 byte sense amps for DQA and two for DQB).

**PRER Command:** A PRER (precharge) command from an ROWR packet causes the selected bank to release its two associated sense amps, permitting a different row in that bank to be activated, or permitting adjacent banks to be activated.

**RD Command:** The RD (read) command causes one of the 64 dualocts of one of the sense amps to be transmitted on the DQA/DQB pins of the Channel.

**WR Command:** The WR (write) command causes a dualoct received from the DQA/DQB data pins of the Channel to be loaded into the write buffer. There is also space in the write buffer for the BC bank address and C column address information. The data in the write buffer is automatically retired (written with optional bytemask) to one of the 64 dualocts of one of the sense amps during a subsequent COP command. A retire can take place during a RD, WR, or NOCOP to another device, or during a WR or NOCOP to the same device. The write buffer will not retire during a RD to the same device. The write buffer reduces the delay needed for the internal DQA/DQB data path turn-around.

**PREC Precharge:** The RDA and WRA commands are similar to RD and WR, except that a precharge operation (PREC) is scheduled at the end of the data transfer. These commands provide a second mechanism for performing precharge.

**PREX Precharge:** After a RD command, or after a WR command with no byte masking (M=0), a COLX packet may be used to specify an extended operation (XOP). The most important XOP command is PREX. This command provides a third mechanism for performing precharge.

**Packet Format**

Figure 3 shows the formats of the ROWA and ROWR packets on the ROW pins. Table 4 describes the fields which comprise these packets. DR4T and DR4F bits are encoded to contain both the DR4 device address bit and a framing bit which allows the ROWA or ROWR packet to be recognized by the RDRAM.

The AV (ROWA/ROWR packet selection) bit distinguishes between the two packet types. Both the ROWA and ROWR packet provide a five bit device address and a four bit bank address. An ROWA packet uses the remaining bits to specify a nine bit row address, and the ROWR packet uses the remaining bits for an eleven bit opcode field. Note the use of the “RsvX” notation to reserve bits for future address field extension.

**Table 4: Field Description for ROWA Packet and ROWR Packet**

Field	Description
DR4T,DR4F	Bits for framing (recognizing) a ROWA or ROWR packet. Also encodes highest device address bit.
DR3..DR0	Device address for ROWA or ROWR packet.
BR3..BR0	Bank address for ROWA or ROWR packet. RsvB denotes bits reserved for future address extension.
AV	Selects between ROWA packet (AV=1) and ROWR packet (AV=0).
R8..R0	Row address for ROWA packet. RsvR denotes bits reserved for future row address extension.
ROP10..ROP0	Opcode field for ROWR packet. Specifies precharge, refresh, and power management functions.

Figure 3 also shows the formats of the COLC, COLM, and COLX packets on the COL pins. Table 5 describes the fields which comprise these packets.

The COLC packet uses the S (Start) bit for framing. A COLM or COLX packet is aligned with this COLC packet, and is also framed by the S bit.

The 23 bit COLC packet has a five bit device address, a four bit bank address, a six bit column address, and a four bit opcode. The COLC packet specifies a read or write command, as well as some power management commands.

The remaining 17 bits are interpreted as a COLM (M=1) or COLX (M=0) packet. A COLM packet is used for a COLC write command which needs bytemask control. The COLM packet is associated with the COLC packet from a time  $t_{RTR}$  earlier. An COLX packet may be used to specify an independent precharge command. It contains a five bit device address, a four bit bank address, and a five bit opcode. The COLX packet may also be used to specify some housekeeping and power management commands. The COLX packet is framed within a COLC packet but is not otherwise associated with any other packet.

**Table 5: Field Description for COLC Packet, COLM Packet, and COLX Packet**

Field	Description
S	Bit for framing (recognizing) a COLC packet, and indirectly for framing COLM and COLX packets.
DC4..DC0	Device address for COLC packet.
BC3..BC0	Bank address for COLC packet. RsvB denotes bits reserved for future bank address extension.
C5..C0	Column address for COLC packet. RsvC denotes bits reserved for future column address extension.
COP3..COP0	Opcode field for COLC packet. Specifies read, write, precharge, and power management functions.
M	Selects between COLM packet (M=1) and COLX packet (M=0).
MA7..MA0	Bytemask write control bits. 1=write, 0=no-write. MA0 controls the earliest byte on DQA8..0.
MB7..MB0	Bytemask write control bits. 1=write, 0=no-write. MB0 controls the earliest byte on DQB8..0.
DX4..DX0	Device address for COLX packet.
BX3..BX0	Bank address for COLX packet. RsvB denotes bits reserved for future bank address extension.
XOP4..XOP0	Opcode field for COLX packet. Specifies precharge, I <sub>OL</sub> control, and power management functions.

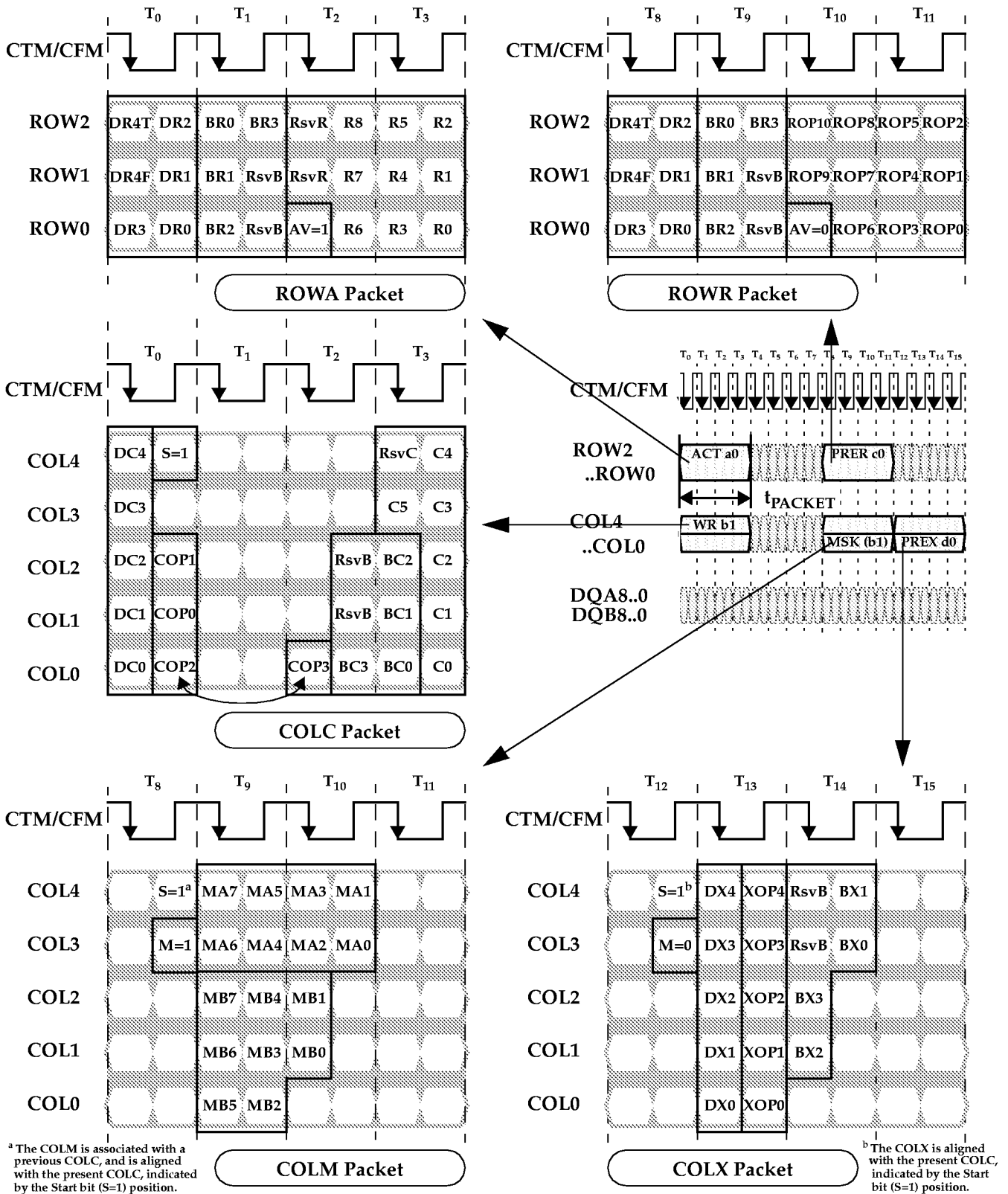

Figure 3: Packet Formats

### Field Encoding Summary

Table 6 shows how the six device address bits are decoded for the ROWA and ROWR packets. The DR4T and DR4F encoding merges a fifth device bit with a framing bit. When neither bit is asserted, the device is

not selected. Note that a broadcast operation is indicated when both bits are set. Broadcast operation would typically be used for refresh and power management commands. If the device is selected, the DM (DeviceMatch) signal is asserted and an ACT or ROP command is performed.

**Table 6: Device Field Encodings for ROWA Packet and ROWR Packet**

DR4T	DR4F	Device Selection	Device Match signal (DM)
1	1	All devices (broadcast)	DM is set to 1
0	1	One device selected	DM is set to 1 if {DEVID4..DEVID0} == {0,DR3..DR0} else DM is set to 0
1	0	One device selected	DM is set to 1 if {DEVID4..DEVID0} == {1,DR3..DR0} else DM is set to 0
0	0	No packet present	DM is set to 0

Table 7 shows the encodings of the remaining fields of the ROWA and ROWR packets. An ROWA packet is specified by asserting the AV bit. This causes the specified row of the specified bank of this device to be loaded into the associated sense amps.

ACT command, except the row address comes from an internal register REFR, and REFR is incremented at the largest bank address. The REFP (refresh-precharge) command is identical to a PRER command.

An ROWR packet is specified when AV is not asserted. An 11 bit opcode field encodes a command for one of the banks of this device. The PRER command causes a bank and its two associated sense amps to precharge, so another row or an adjacent bank may be activated. The REFA (refresh-activate) command is similar to the

The NAPR, NAPRC, PDNR, ATTN, and RLXR commands are used for managing the power dissipation of the RDRAM and are described in more detail in “Power State Management” on page 38. The TCEN and TCAL commands are used to adjust the output driver slew rate and they are described in more detail in “Current and Temperature Control” on page 43.

**Table 7: ROWA Packet and ROWR Packet Field Encodings**

DM <sup>a</sup>	AV	ROP10..ROP0 Field										Name	Command Description
		10	9	8	7	6	5	4	3	2:0			
0	-	-	-	-	-	-	-	-	-	-	---	-	No operation.
1	1	Row address										ACT	Activate row R8..R0 of bank BR3..BR0 of device and move device to ATTN <sup>b</sup> .
1	0	1	1	0	0	0	x <sup>c</sup>	x	x	x	000	PRER	Precharge bank BR3..BR0 of this device.
1	0	0	0	0	1	1	0	0	x	x	000	REFA	Refresh (activate) row REFR8..REFR0 of bank BR3..BR0 of device. Increment REFR if BR3..BR0 = 1111 (see Figure 49).
1	0	1	0	1	0	1	0	0	x	x	000	REFP	Precharge bank BR3..BR0 of this device after REFA (see Figure 49).
1	0	x	x	0	0	0	0	1	x	x	000	PDNR	Move this device into the powerdown (PDN) power state (see Figure 46).
1	0	x	x	0	0	0	1	0	x	x	000	NAPR	Move this device into the nap (NAP) power state (see Figure 46).
1	0	x	x	0	0	0	1	1	x	x	000	NAPRC	Move this device into the nap (NAP) power state conditionally
1	0	x	x	x	x	x	x	x	0	0	000	ATTN <sup>b</sup>	Move this device into the attention (ATTN) power state (see Figure 44).
1	0	x	x	x	x	x	x	x	1	0	000	RLXR	Move this device into the standby (STBY) power state (see Figure 45).
1	0	0	0	0	0	0	0	0	x	001	TCAL	Temperature calibrate this device (see Figure 51).	
1	0	0	0	0	0	0	0	0	x	010	TCEN	Temperature calibrate/enable this device (see Figure 51).	
1	0	0	0	0	0	0	0	0	0	000	NOROP	No operation.	

a. The DM (Device Match signal) value is determined by the DR4T,DR4F, DR3..DR0 field of the ROWA and ROWR packets. See Table 6.  
 b. The device’s power state remains unchanged for a broadcast operation (DR4T/DR4F=1/1).  
 c. An “x” entry indicates which commands may be combined. For instance, the three commands PRER/NAPRC/RLXR may be specified in one ROP value (011000111000).

Table 8 shows the COP field encoding. The device must be in the ATTN power state in order to receive COLC packets. The COLC packet is used primarily to specify RD (read) and WR (write) commands. Retire operations (moving data from the write buffer to a sense amp) happen automatically. See Figure 17 for a more detailed description.

The COLC packet can also specify a PREC command, which precharges a bank and its associated sense amps. The RDA/WRA commands are equivalent to a RD/WR followed by a PREC. RLXC (relax) performs a power mode transition. See “Power State Management” on page 38.

**Table 8: COLC Packet Field Encodings**

S	DC4.. DC0 (select device) <sup>a</sup>	COP3..0	Name	Command Description
0	----	----	-	No operation.
1	/= (DEVID4 ..0)	----	-	Retire write buffer of this device.
1	== (DEVID4 ..0)	x000 <sup>b</sup>	NOCOP	Retire write buffer of this device.
1	== (DEVID4 ..0)	x001	WR	Retire write buffer of this device, then write column C5..C0 of bank BC3..BC0 to write buffer.
1	== (DEVID4 ..0)	x010	RSRV	Reserved, no operation.
1	== (DEVID4 ..0)	x011	RD	Read column C5..C0 of bank BC3..BC0 of this device.
1	== (DEVID4 ..0)	x100	PREC	Retire write buffer of this device, then precharge bank BC3..BC0 (see Figure 14).
1	== (DEVID4 ..0)	x101	WRA	Same as WR, but precharge bank BC3..BC0 after write buffer (with new data) is retired.
1	== (DEVID4 ..0)	x110	RSRV	Reserved, no operation.
1	== (DEVID4 ..0)	x111	RDA	Same as RD, but precharge bank BC3..BC0 afterward.
1	== (DEVID4 ..0)	1xxx	RLXC	Move this device into the standby (STBY) power state (see Figure 45).

a. “/=” means not equal, “==” means equal.

b. An “x” entry indicates which commands may be combined. For instance, the two commands WR/RLXC may be specified in one COP value (1001).

Table 9 shows the COLM and COLX field encodings. The M bit is asserted to specify a COLM packet with two 8 bit bytemask fields MA and MB. If the M bit is not asserted, an COLX is specified. It has device and bank address fields, and an opcode field. The primary use of the COLX packet is to permit an independent PREX (precharge) command to be specified without

consuming control bandwidth on the ROW pins. It is also used for the CAL(calibrate) and SAM (sample) current control commands (see “Current and Temperature Control” on page 43), and for the RLXX power mode command (see “Power State Management” on page 38).

**Table 9: COLM Packet and COLX Packet Field Encodings**

M	DX4 .. DX0 (selects device)	XOP4..0	Name	Command Description
1	----	-	MSK	MB/MA bytemasks used by WR/WRA.
0	/= (DEVID4 ..0)	-	-	No operation.
0	== (DEVID4 ..0)	00000	NOXOP	No operation.
0	== (DEVID4 ..0)	1xxx0 <sup>a</sup>	PREX	Precharge bank BX3..BX0 of this device (see Figure 14).
0	== (DEVID4 ..0)	x1xx0	CAL	Calibrate (drive) I <sub>OL</sub> current for this device (see Figure 50).
0	== (DEVID4 ..0)	xx1x0	SAM	Sample ( update) I <sub>OL</sub> current for this device (see Figure 50).
0	== (DEVID4 ..0)	xxx10	RLXX	Move this device into the standby (STBY) power state (see Figure 45).
0	== (DEVID4 ..0)	xxxx1	RSRV	Reserved, no operation.

a. An “x” entry indicates which commands may be combined. For instance, the two commands PREX/RLXX may be specified in one XOP value (10010).

### DQ Packet Timing

Figure 4 shows the timing relationship of COLC packets with D and Q data packets. This document uses a specific convention for measuring time intervals between packets: all packets on the ROW and COL pins (ROWA, ROWR, COLC, COLM, COLX) use the trailing edge of the packet as a reference point, and all packets on the DQA/DQB pins (D and Q) use the leading edge of the packet as a reference point.

An RD or RDA command will transmit a dualoct of read data Q a time  $t_{CAC}$  later. This time includes one to five cycles of round-trip propagation delay on the Channel. The  $t_{CAC}$  parameter may be programmed to a one of a range of values (7, 8, 9, 10, 11, or 12  $t_{CYCLE}$ ). The value chosen depends upon the number of RDRAM devices on the Channel and the RDRAM timing bin. See Figure 39 for more information.

A WR or WRA command will receive a dualoct of write data D a time  $t_{CWD}$  later. This time does not need to include the round-trip propagation time of the Channel since the COLC and D packets are traveling in the same direction.

When a Q packet follows a D packet (shown in the left half of the figure), a gap ( $t_{CAC} - t_{CWD}$ ) will automatically appear between them because the  $t_{CWD}$  value is always less than the  $t_{CAC}$  value. There will be no gap between the two COLC packets with the WR and RD commands which schedule the D and Q packets.

When a D packet follows a Q packet (shown in the right half of the figure), no gap is needed between them because the  $t_{CWD}$  value is less than the  $t_{CAC}$  value. However, a gap of  $t_{CAC} - t_{CWD}$  or greater must be inserted between the COLC packets with the RD WR commands by the controller so the Q and D packets do not overlap.

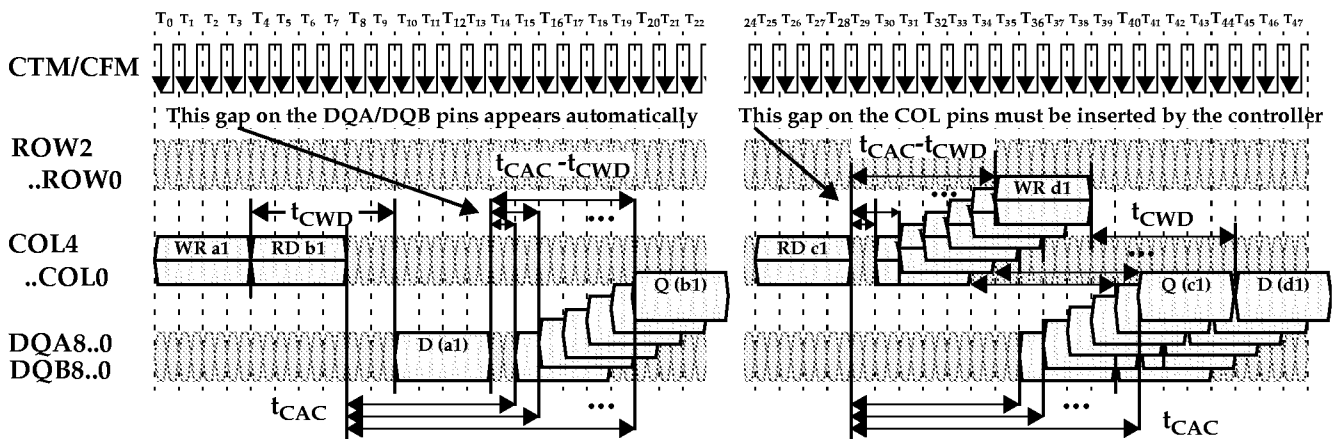

Figure 4: Read (Q) and Write (D) Data Packet - Timing for  $t_{CAC} = 7, 8, 9, 10, 11, \text{ or } 12 t_{CYCLE}$

### COLM Packet to D Packet Mapping

Figure 5 shows a write operation initiated by a WR command in a COLC packet. If a subset of the 16 bytes of write data are to be written, then a COLM packet is transmitted on the COL pins a time  $t_{RTR}$  after the COLC packet containing the WR command. The M bit of the COLM packet is set to indicate that it contains the MA and MB mask fields. Note that this COLM packet is aligned with the COLC packet which causes the write buffer to be retired. See Figure 17 for more details.

If all 16 bytes of the D data packet are to be written, then no further control information is required. The packet slot that would have been used by the COLM packet ( $t_{RTR}$  after the COLC packet) is available to be

used as an COLX packet. This could be used for a PREX precharge command or for a housekeeping command (this case is not shown). The M bit is not asserted in an COLX packet and causes all 16 bytes of the previous WR to be written unconditionally. Note that a RD command will never need a COLM packet, and will always be able to use the COLX packet option (a read operation has no need for the byte-write-enable control bits).

Figure 5 also shows the mapping between the MA and MB fields of the COLM packet and bytes of the D packet on the DQA and DQB pins. Each mask bit controls whether a byte of data is written (=1) or not written (=0).

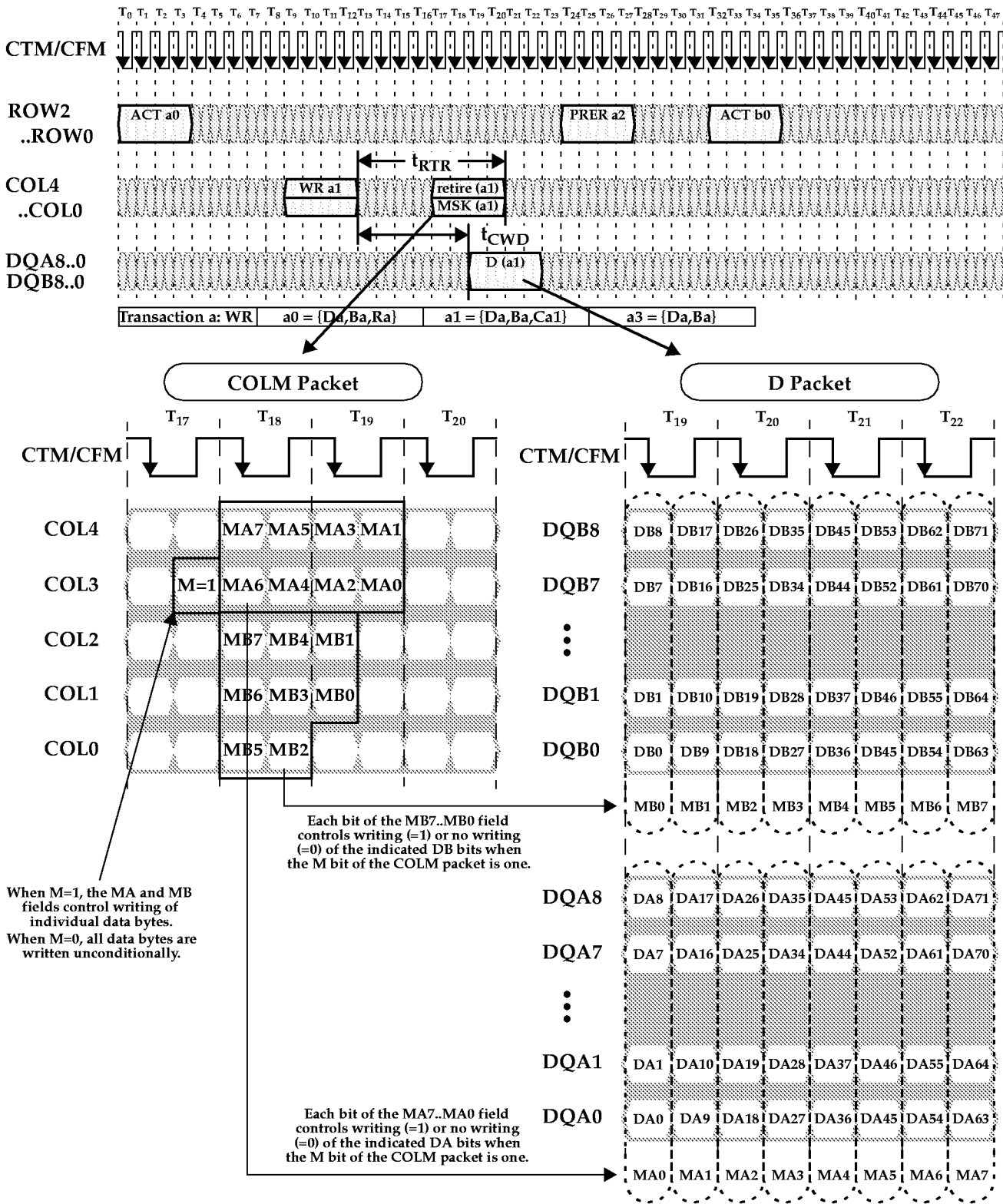
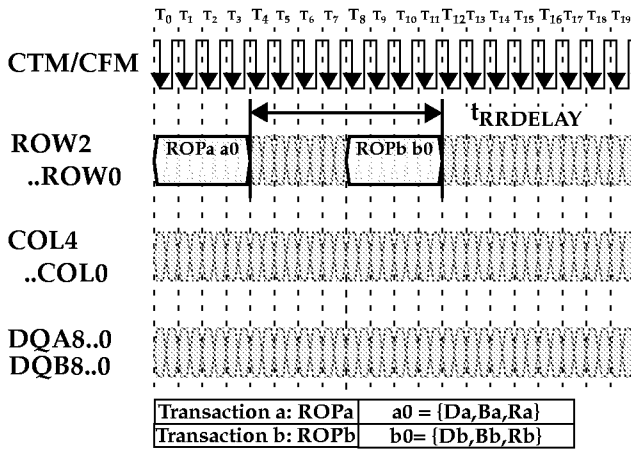

Figure 5: Mapping Between COLM Packet and D Packet for WR Command

**ROW-to-ROW Packet Interaction**



**Figure 6: ROW-to-ROW Packet Interaction- Timing**

Figure 6 shows two packets on the ROW pins separated by an interval  $t_{RRDELAY}$  which depends upon the packet contents. No other ROW packets are sent to banks {Ba,Ba+1,Ba-1} between packet “a” and packet “b” unless noted otherwise. Table 10 summarizes the  $t_{RRDELAY}$  values for all possible cases.

Cases RR1 through RR4 show two successive ACT commands. In case RR1, there is no restriction since the ACT commands are to different devices. In case RR2, the  $t_{RR}$  restriction applies to the same device with non-adjacent banks. Cases RR3 and RR4 are illegal (as shown) since bank Ba needs to be precharged. If a PRER to Ba, Ba+1, or Ba-1 is inserted,  $t_{RRDELAY}$  is  $t_{RC}$  ( $t_{RAS}$  to the PRER command, and  $t_{RP}$  to the next ACT).

Cases RR5 through RR8 show an ACT command followed by a PRER command. In cases RR5 and RR6, there are no restrictions since the commands are to different devices or to non-adjacent banks of the same device. In cases RR7 and RR8, the  $t_{RAS}$  restriction means the activated bank must wait before it can be precharged.

Cases RR9 through RR12 show a PRER command followed by an ACT command. In cases RR9 and RR10, there are essentially no restrictions since the commands are to different devices or to non-adjacent banks of the same device. RR10a and RR10b depend upon whether a bracketed bank (Ba+1) is precharged or activated. In cases RR11 and RR12, the same and adjacent banks must all wait  $t_{RP}$  for the sense amp and bank to precharge before being activated.

**Table 10: ROW-to-ROW Packet Interaction - Rules**

Case #	ROPa	Da	Ba	Ra	ROPb	Db	Bb	Rb	$t_{RRDELAY}$	Example
RR1	ACT	Da	Ba	Ra	ACT	/= Da	xxxx	x..x	$t_{PACKET}$	Figure 11
RR2	ACT	Da	Ba	Ra	ACT	== Da	/= {Ba,Ba+1,Ba-1}	x..x	$t_{RR}$	Figure 11
RR3	ACT	Da	Ba	Ra	ACT	== Da	== {Ba+1,Ba-1}	x..x	$t_{RC}$ - illegal unless PRER to Ba/Ba+1/Ba-1	Figure 10
RR4	ACT	Da	Ba	Ra	ACT	== Da	== {Ba}	x..x	$t_{RC}$ - illegal unless PRER to Ba/Ba+1/Ba-1	Figure 10
RR5	ACT	Da	Ba	Ra	PRER	/= Da	xxxx	x..x	$t_{PACKET}$	Figure 11
RR6	ACT	Da	Ba	Ra	PRER	== Da	/= {Ba,Ba+1,Ba-1}	x..x	$t_{PACKET}$	Figure 11
RR7	ACT	Da	Ba	Ra	PRER	== Da	== {Ba+1,Ba-1}	x..x	$t_{RAS}$	Figure 10
RR8	ACT	Da	Ba	Ra	PRER	== Da	== {Ba}	x..x	$t_{RAS}$	Figure 15
RR9	PRER	Da	Ba	Ra	ACT	/= Da	xxxx	x..x	$t_{PACKET}$	Figure 12
RR10	PRER	Da	Ba	Ra	ACT	== Da	/= {Ba,Ba+1,Ba+2}	x..x	$t_{PACKET}$	Figure 12
RR10a	PRER	Da	Ba	Ra	ACT	== Da	== {Ba+2}	x..x	$t_{PACKET}/t_{RP}$ if Ba+1 is precharged/activated.	
RR10b	PRER	Da	Ba	Ra	ACT	== Da	== {Ba-2}	x..x	$t_{PACKET}/t_{RP}$ if Ba-1 is precharged/activated.	
RR11	PRER	Da	Ba	Ra	ACT	== Da	== {Ba+1,Ba-1}	x..x	$t_{RP}$	Figure 10
RR12	PRER	Da	Ba	Ra	ACT	== Da	== {Ba}	x..x	$t_{RP}$	Figure 10
RR13	PRER	Da	Ba	Ra	PRER	/= Da	xxxx	x..x	$t_{PACKET}$	Figure 12
RR14	PRER	Da	Ba	Ra	PRER	== Da	/= {Ba,Ba+1,Ba-1}	x..x	$t_{PP}$	Figure 12
RR15	PRER	Da	Ba	Ra	PRER	== Da	== {Ba+1,Ba-1}	x..x	$t_{PP}$	Figure 12
RR16	PRER	Da	Ba	Ra	PRER	== Da	== Ba	x..x	$t_{PP}$	Figure 12

### ROW-to-ROW Interaction - continued

Cases RR13 through RR16 summarize the combinations of two successive PRER commands. In case RR13 there is no restriction since two devices are addressed. In RR14,  $t_{pp}$  applies, since the same device is addressed. In RR15 and RR16, the same bank or an adjacent bank may be given repeated PRER commands with only the  $t_{pp}$  restriction.

Two adjacent banks can't be activate simultaneously. A precharge command to one bank will thus affect the state of the adjacent banks (and sense amps). If bank Ba is activate and a PRER is directed to Ba, then bank Ba will be precharged along with sense amps Ba-1/Ba and Ba/Ba+1. If bank Ba+1 is activate and a PRER is directed to Ba, then bank Ba+1 will be precharged along with sense amps Ba/Ba+1 and Ba+1/Ba+2. If bank Ba-1 is activate and a PRER is directed to Ba, then bank Ba-1 will be precharged along with sense amps Ba/Ba-1 and Ba-1/Ba-2.

A ROW packet may contain commands other than ACT or PRER. The REFA and REFP commands are equivalent to ACT and PRER for interaction analysis purposes. The interaction rules of the NAPR, NAPRC, PDNR, RLXR, ATTN, TCAL, and TCEN commands are discussed in later sections (see Table 7 for cross-ref).

### ROW-to-COL Packet Interaction

Figure 7 shows two packets on the ROW and COL pins. They must be separated by an interval  $t_{RCDELAY}$  which depends upon the packet contents. Table 11 summarizes the  $t_{RCDELAY}$  values for all possible cases. Note that if the COL packet is earlier than the ROW packet, it is considered a COL-to-ROW packet interaction.

Cases RC1 through RC5 summarize the rules when the ROW packet has an ACT command. Figure 15 and Figure 16 show examples of RC5 - an activation followed by a read or write. RC4 is an illegal situation, since a read or write of a precharged banks is being attempted (remember that for a bank to be activated, adjacent banks must be precharged). In cases RC1, RC2, and RC3, there is no interaction of the ROW and COL packets.

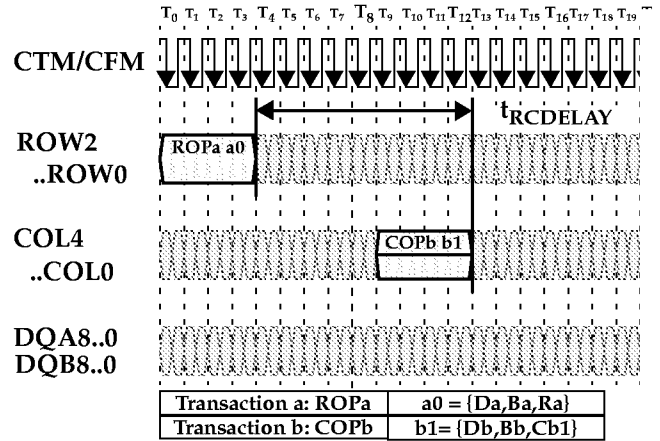

Figure 7: ROW-to-COL Packet Interaction- Timing

Cases RC6 through RC8 summarize the rules when the ROW packet has a PRER command. There is either no interaction (RC6 through RC9) or an illegal situation with a read or write of a precharged bank (RC9).

The COL pins can also schedule a precharge operation with a RDA, WRA, or PREC command in a COLC packet or a PREX command in a COLX packet. The constraints of these precharge operations may be converted to equivalent PRER command constraints using the rules summarized in Figure 14.

Table 11: ROW-to-COL Packet Interaction - Rules

Case #	ROPa	Da	Ba	Ra	COPb	Db	Bb	Cb1	$t_{RCDELAY}$	Example
RC1	ACT	Da	Ba	Ra	NOCOP,RD,WR	/= Da	xxxx	x..x	0	
RC2	ACT	Da	Ba	Ra	NOCOP	== Da	xxxx	x..x	0	
RC3	ACT	Da	Ba	Ra	RD,WR	== Da	/= {Ba,Ba+1,Ba-1}	x..x	0	
RC4	ACT	Da	Ba	Ra	RD,WR	== Da	== {Ba+1,Ba-1}	x..x	Illegal	
RC5	ACT	Da	Ba	Ra	RD,WR	== Da	== Ba	x..x	$t_{RCD}$	Figure 15
RC6	PRER	Da	Ba	Ra	NOCOP,RD,WR	/= Da	xxxx	x..x	0	
RC7	PRER	Da	Ba	Ra	NOCOP	== Da	xxxx	x..x	0	

**Table 11: ROW-to-COL Packet Interaction - Rules**

Case #	ROPa	Da	Ba	Ra	COPb	Db	Bb	Cb1	t <sub>RCDELAY</sub>	Example
RC8	PRER	Da	Ba	Ra	RD,WR	== Da	/= {Ba,Ba+1,Ba-1}	x..x	0	
RC9	PRER	Da	Ba	Ra	RD,WR	== Da	== {Ba+1,Ba-1}	x..x	Illegal	

### COL-to-COL Packet Interaction

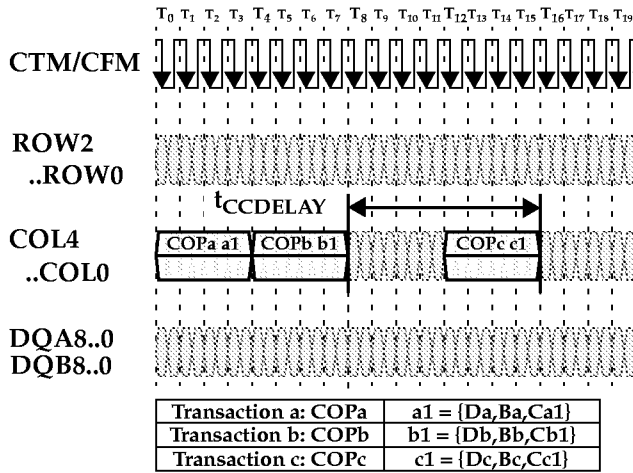

Figure 8: COL-to-COL Packet Interaction- Timing

Figure 8 shows three arbitrary packets on the COL pins. Packets “b” and “c” must be separated by an interval  $t_{CCDELAY}$  which depends upon the command and address values in all three packets. Table 12 summarizes the  $t_{CCDELAY}$  values for all possible cases.

Cases CC1 through CC5 summarize the rules for every situation other than the case when COPb is a WR command and COPc is a RD command. In CC3, when a RD command is followed by a WR command, a gap of  $t_{CAC} - t_{CWD}$  must be inserted between the two COL packets. See Figure 4 for more explanation of why this

gap is needed. For cases CC1, CC2, CC4, and CC5, there is no restriction ( $t_{CCDELAY}$  is  $t_{CC}$ ).

In cases CC6 through CC10, COPb is a WR command and COPc is a RD command. The  $t_{CCDELAY}$  value needed between these two packets depends upon the command and address in the packet with COPa. In particular, in case CC6 when there is WR-WR-RD command sequence directed to the same device, a gap will be needed between the packets with COPb and COPc. The gap will need a COLC packet with a NOCOP command directed to any device in order to force an automatic retire to take place. Figure 18 (right) provides a more detailed explanation of this case.

In case CC10, there is a RD-WR-RD sequence directed to the same device. If a prior write to the same device is unretired when COPa is issued, then a gap will be needed between the packets with COPb and COPc as in case CC6. The gap will need a COLC packet with a NOCOP command directed to any device in order to force an automatic retire to take place.

Cases CC7, CC8, and CC9 have no restriction ( $t_{CCDELAY}$  is  $t_{CC}$ ).

For the purposes of analyzing COL-to-ROW interactions, the PREC, WRA, and RDA commands of the COLC packet are equivalent to the NOCOP, WR, and RD commands. These commands also cause a precharge operation PREC to take place. This precharge may be converted to an equivalent PRER command on the ROW pins using the rules summarized in Figure 14.

Table 12: COL-to-COL Packet Interaction - Rules

Case #	COPa	Da	Ba	Ca1	COPb	Db	Bb	Cb1	COPc	Dc	Bc	Cc1	$t_{CCDELAY}$	Example
CC1	xxxx	xxxxx	x..x	x..x	NOCOP	Db	Bb	Cb1	xxxx	xxxxx	x..x	x..x	$t_{CC}$	
CC2	xxxx	xxxxx	x..x	x..x	RD,WR	Db	Bb	Cb1	NOCOP	xxxxx	x..x	x..x	$t_{CC}$	
CC3	xxxx	xxxxx	x..x	x..x	RD	Db	Bb	Cb1	WR	xxxxx	x..x	x..x	$t_{CC} + t_{CAC} - t_{CWD}$	Figure 4
CC4	xxxx	xxxxx	x..x	x..x	RD	Db	Bb	Cb1	RD	xxxxx	x..x	x..x	$t_{CC}$	Figure 15
CC5	xxxx	xxxxx	x..x	x..x	WR	Db	Bb	Cb1	WR	xxxxx	x..x	x..x	$t_{CC}$	Figure 16
CC6	WR	== Db	x	x..x	WR	Db	Bb	Cb1	RD	== Db	x..x	x..x	$t_{RTR}$	Figure 17
CC7	WR	== Db	x	x..x	WR	Db	Bb	Cb1	RD	/= Db	x..x	x..x	$t_{CC}$	
CC8	WR	/= Db	x	x..x	WR	Db	Bb	Cb1	RD	== Db	x..x	x..x	$t_{CC}$	
CC9	NOCOP	== Db	x	x..x	WR	Db	Bb	Cb1	RD	== Db	x..x	x..x	$t_{CC}$	
CC10	RD	== Db	x	x..x	WR	Db	Bb	Cb1	RD	== Db	x..x	x..x	$t_{CC}$ or $t_{RTR}^a$	

a. If the write buffer was full from an earlier WR command, and had not been retired when COPa=RD is executed,  $t_{CCDELAY}$  will be constrained by the  $t_{RTR}$  parameter. Otherwise, the  $t_{CC}$  parameter will apply.

### COL-to-ROW Packet Interaction

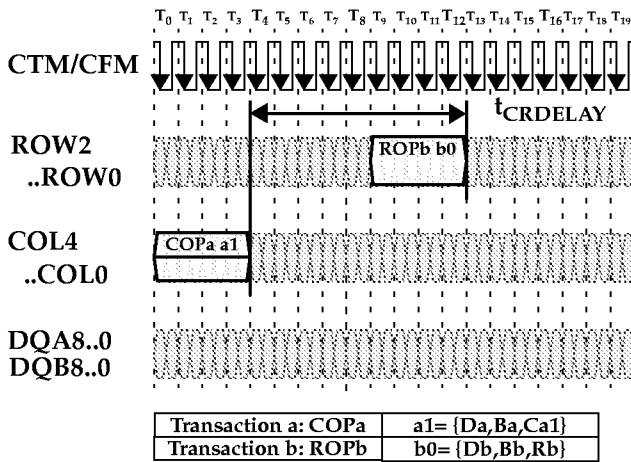

Figure 9: COL-to-ROW Packet Interaction- Timing

Figure 9 shows arbitrary packets on the COL and ROW pins. They must be separated by an interval t<sub>CRDELAY</sub> which depends upon the command and address values in the packets. Table 13 summarizes the t<sub>CRDELAY</sub> value for all possible cases.

Cases CR1, CR2, CR3, and CR9 show no interaction between the COL and ROW packets, either because one of the commands is a NOP or because the packets are directed to different devices or to non-adjacent banks.

Case CR4 is illegal because an already-activated bank is to be re-activated without being precharged. Case CR5 is illegal because an adjacent bank can't be activated or precharged until bank Ba is precharged first.

In case CR6, the COLC packet contains a RD command, and the ROW packet contains a PRER command for the same bank. The t<sub>RDP</sub> parameter specifies the required spacing.

Likewise, in case CR7, the COLC packet causes an automatic retire to take place, and the ROW packet contains a PRER command for the same bank. The t<sub>RTP</sub> parameter specifies the required spacing.

Case CR8 is labeled "Hazardous" because a WR command should always be followed by an automatic retire before a precharge is scheduled. Figure 19 shows an example of what can happen when the retire is not able to happen before the precharge.

For the purposes of analyzing COL-to-ROW interactions, the PREC, WRA, and RDA commands of the COLC packet are equivalent to the NOCOP, WR, and RD commands. These commands also cause a precharge operation to take place. This precharge may be converted to an equivalent PRER command on the ROW pins using the rules summarized in Figure 14.

A ROW packet may contain commands other than ACT or PRER. The REFA and REFP commands are equivalent to ACT and PRER for interaction analysis purposes. The interaction rules of the NAPR, PDNR, and RLXR commands are discussed in a later section.

Table 13: COL-to-ROW Packet Interaction - Rules

Case #	COPa	Da	Ba	Ca1	ROPb	Db	Bb	Rb	t <sub>CRDELAY</sub>	Example
CR1	NOCOP	Da	Ba	Ca1	x..x	xxxxx	xxxx	x..x	0	
CR2	RD/WR	Da	Ba	Ca1	x..x	/= Da	xxxx	x..x	0	
CR3	RD/WR	Da	Ba	Ca1	x..x	== Da	/= {Ba,Ba+1,Ba-1}	x..x	0	
CR4	RD/WR	Da	Ba	Ca1	ACT	== Da	== {Ba}	x..x	Illegal	
CR5	RD/WR	Da	Ba	Ca1	x..x	== Da	== {Ba+1,Ba-1}	x..x	Illegal	
CR6	RD	Da	Ba	Ca1	PRER	== Da	== {Ba,Ba+1,Ba-1}	x..x	t <sub>RDP</sub>	Figure 15
CR7	retire <sup>a</sup>	Da	Ba	Ca1	PRER	== Da	== {Ba,Ba+1,Ba-1}	x..x	t <sub>RTP</sub>	Figure 16
CR8	WR <sup>b</sup>	Da	Ba	Ca1	PRER	== Da	== {Ba,Ba+1,Ba-1}	x..x	0	Figure 19
CR9	xxxx	Da	Ba	Ca1	NOROP	xxxxx	xxxx	x..x	0	

a. This is any command which permits the write buffer of device Da to retire (see Table 8). "Ba" is the bank address in the write buffer.

b. This situation is hazardous because the write buffer will be left unretired while the targeted bank is precharged. See Figure 19.

### ROW-to-ROW Examples

Figure 10 shows examples of some of the the ROW-to-ROW packet spacings from Table 10. A complete sequence of activate and precharge commands is directed to a bank. The RR8 and RR12 rules apply to this sequence. In addition to satisfying the  $t_{RAS}$  and  $t_{RP}$  timing parameters, the separation between ACT

commands to the same bank must also satisfy the  $t_{RC}$  timing parameter (RR4).

When a bank is activated, it is necessary for adjacent banks to remain precharged. As a result, the adjacent banks will also satisfy parallel timing constraints; in the example, the RR11 and RR3 rules are analogous to the RR12 and RR4 rules.

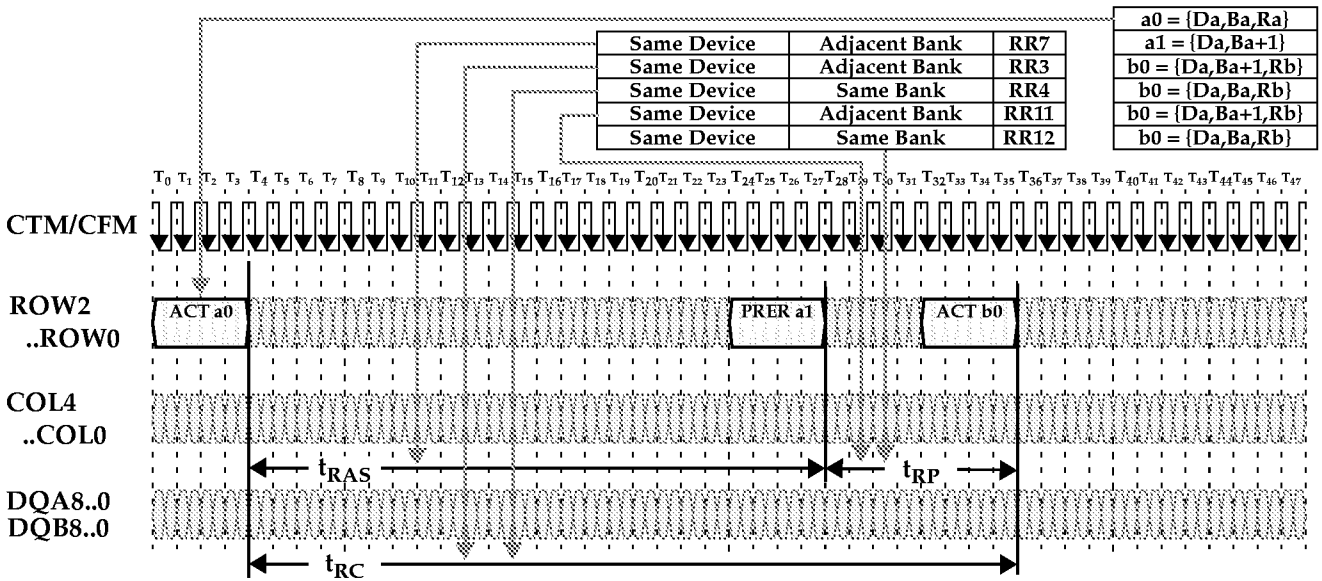

Figure 10: Row Packet Example

Figure 11 shows examples of the ACT-to-ACT (RR1, RR2) and ACT-to-PRER (RR5, RR6) command spacings from Table 10. In general, the commands in ROW packets may be spaced an interval  $t_{PACKET}$  apart

unless they are directed to the same or adjacent banks or unless they are a similar command type (both PRER or both ACT) directed to the same device.

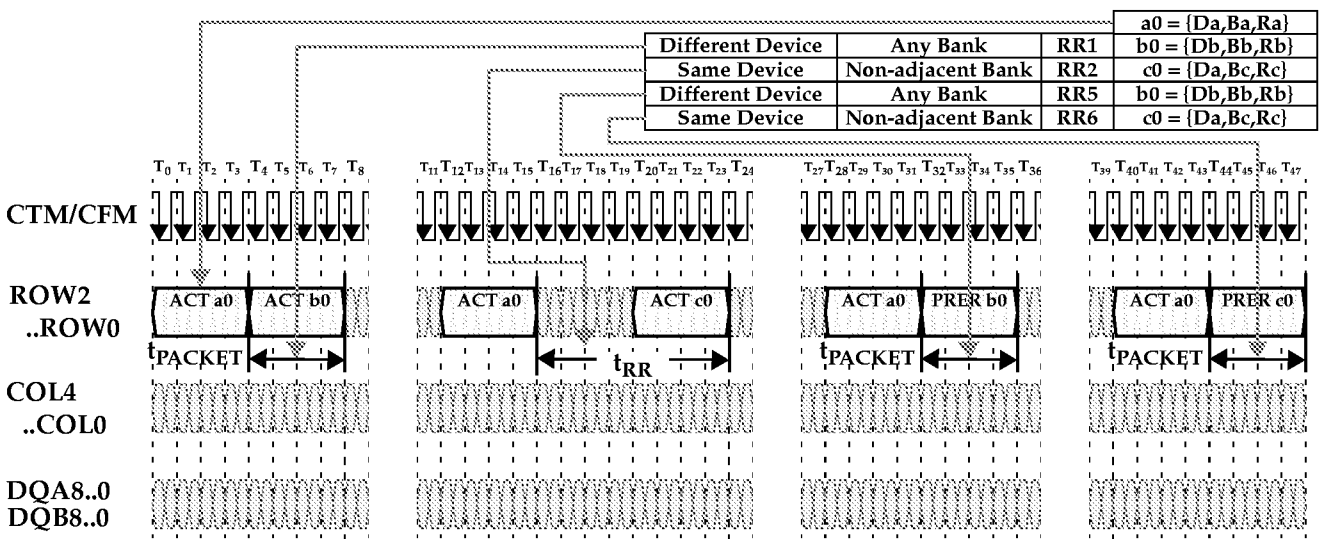

Figure 11: Row Packet Example

Figure 12 shows examples of the PRER-to-PRER (RR13, RR14) and PRER-to-ACT (RR9, RR10) command spacings from Table 10. The RR15 and RR16 cases (PRER-to-PRER to same or adjacent banks) are not shown, but are similar to RR14. In general, the

commands in ROW packets may be spaced an interval  $t_{\text{PACKET}}$  apart unless they are directed to the same or adjacent banks or unless they are a similar command type (both PRER or both ACT) directed to the same device.

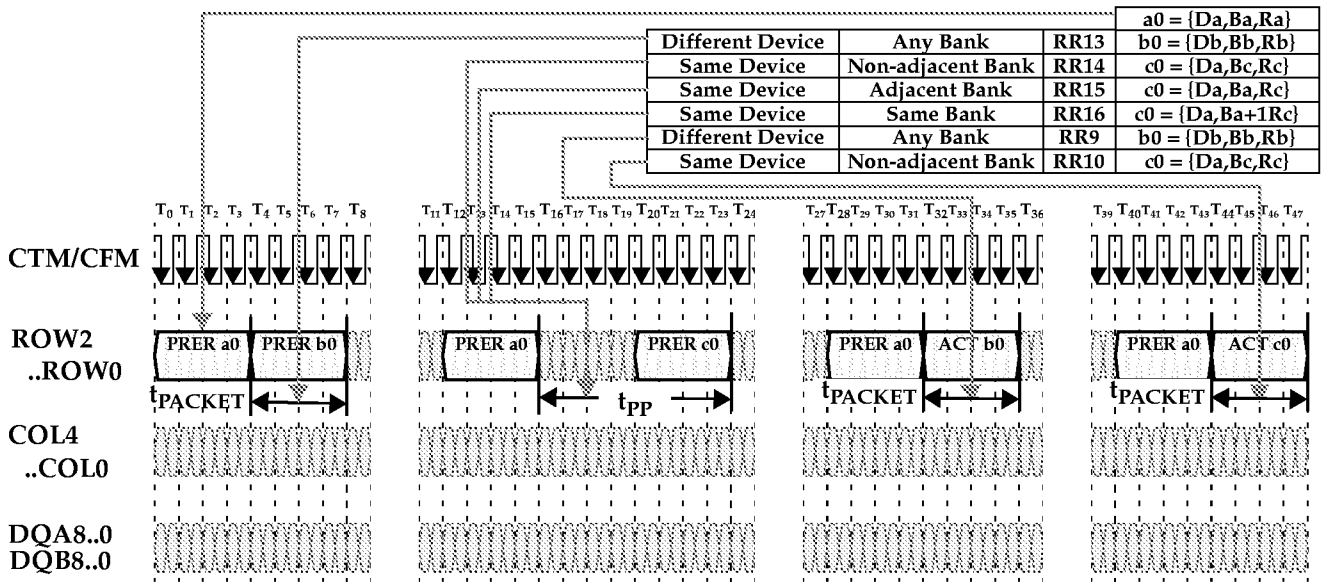

Figure 12: Row Packet Examples

### Row and Column Cycle Description

**Activate:** A row cycle begins with the activate (ACT) operation. The activation process is destructive; the act of sensing the value of a bit in a bank’s storage cell transfers the bit to the sense amp, but leaves the original bit in the storage cell with an incorrect value.

**Restore:** Because the activation process is destructive, a hidden operation called restore is automatically performed. The restore operation rewrites the bits in the sense amp back into the storage cells of the activated row of the bank.

**Read/Write:** While the restore operation takes place, the sense amp may be read (RD) and written (WR) using column operations. If new data is written into the sense amp, it is automatically forwarded to the storage cells of the bank so the data in the activated row and the data in the sense amp remain identical.

**Precharge:** When both the restore operation and the column operations are completed, the sense amp and bank are precharged (PRE). This leaves them in the proper state to begin another activate operation.

**Intervals:** The activate operation requires the interval  $t_{\text{RCD,MIN}}$  to complete. The hidden restore operation

requires the interval  $t_{\text{RAS,MIN}} - t_{\text{RCD,MIN}}$  to complete. Column read and write operations are also performed during the  $t_{\text{RAS,MIN}} - t_{\text{RCD,MIN}}$  interval (if more than about four column operations are performed, this interval must be increased). The precharge operation requires the interval  $t_{\text{RP,MIN}}$  to complete.

**Adjacent Banks:** An RDRAM with a “d” designation (256Kx16d/18) indicates it contains “doubled banks”. This means the sense amps are shared between two adjacent banks. The only exception is that sense amp 0 and sense amp 15 are not shared. When a row in a bank is activated, the two adjacent sense amps are connected to (associated with) that bank and are not available for use by the two adjacent banks. These two adjacent banks must remain precharged while the selected bank goes through its activate, restore, read/write, and precharge operations.

For example (referring to the block diagram of Figure 2), if bank 5 is accessed, sense amp 4/5 and sense amp 5/6 will both be loaded with one of the 512 rows (with 512 bytes loaded into each sense amp from the 1Kbyte row - 256 bytes to the DQA side and 256 bytes to the DQB side). While this row from bank 5 is being accessed, no rows may be accessed in banks 4 or 6 because of the sense amp sharing.

### Precharge Mechanisms

Figure 13 shows an example of precharge with the ROWR packet mechanism. The PRER command must

occur a time  $t_{RAS}$  after the ACT command, and a time  $t_{RP}$  before the next ACT command. This timing will serve as a baseline against which the other precharge mechanisms can be compared.

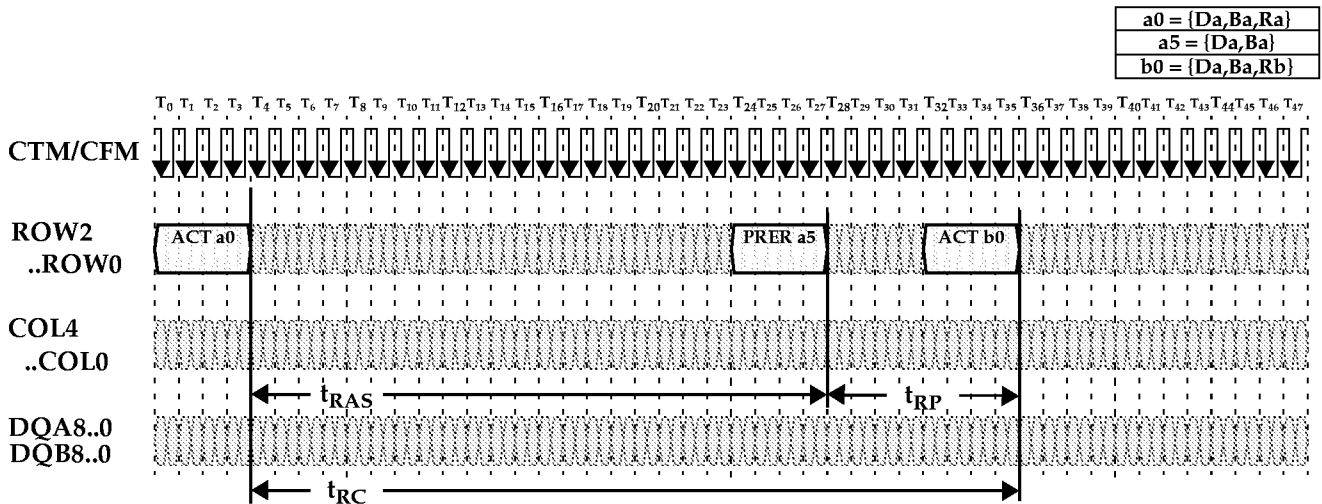

Figure 13: Precharge via PRER Command in ROWR Packet

Figure 14 (top) shows an example of precharge with a RDA command. A bank is activated with an ROWA packet on the ROW pins. Then, a series of four dualocts are read with RD commands in COLC packets on the COL pins. The fourth of these commands is a RDA, which causes the bank to automatically precharge when the final read has finished. The timing of this automatic precharge is equivalent to a PRER command in an ROWR packet on the ROW pins that is offset a time  $t_{OFFP}$  from the COLC packet with the RDA command. The RDA command should be treated as a RD command in a COLC packet as well as a simultaneous (but offset) PRER command in an ROWR packet when analyzing interactions with other packets.

analyzing interactions with other packets. Note that the automatic retire is triggered by a COLC packet a time  $t_{RTR}$  after the COLC packet with the WR command unless the second COLC contains a RD command to the same device. This is described in more detail in Figure 17.

Figure 14 (middle) shows an example of precharge with a WRA command. As in the RDA example, a bank is activated with an ROWA packet on the ROW pins. Then, two dualocts are written with WR commands in COLC packets on the COL pins. The second of these commands is a WRA, which causes the bank to automatically precharge when the final write has been retired. The timing of this automatic precharge is equivalent to a PRER command in an ROWR packet on the ROW pins that is offset a time  $t_{OFFP}$  from the COLC packet that causes the automatic retire. The WRA command should be treated as a WR command in a COLC packet as well as a simultaneous (but offset) PRER command in an ROWR packet when

Figure 14 (bottom) shows an example of precharge with a PREX command in an COLX packet. A bank is activated with an ROWA packet on the ROW pins. Then, a series of four dualocts are read with RD commands in COLC packets on the COL pins. The fourth of these COLC packets includes an COLX packet with a PREC command. This causes the bank to precharge with timing equivalent to a PRER command in an ROWR packet on the ROW pins that is offset a time  $t_{OFFP}$  from the COLX packet with the PREX command.

**COLC Packet: RDA Precharge Offset**

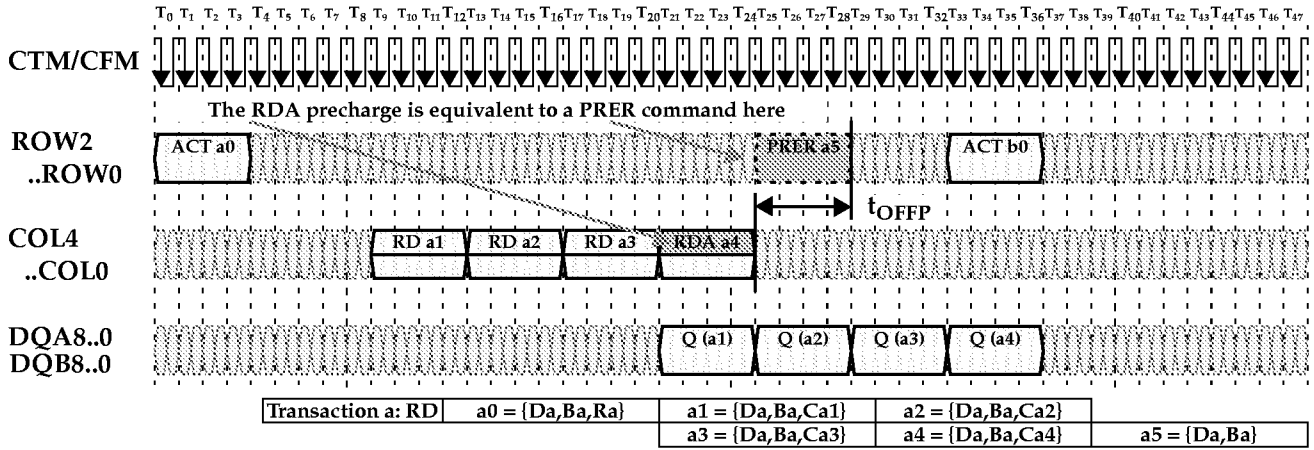

**COLC Packet: WDA Precharge Offset**

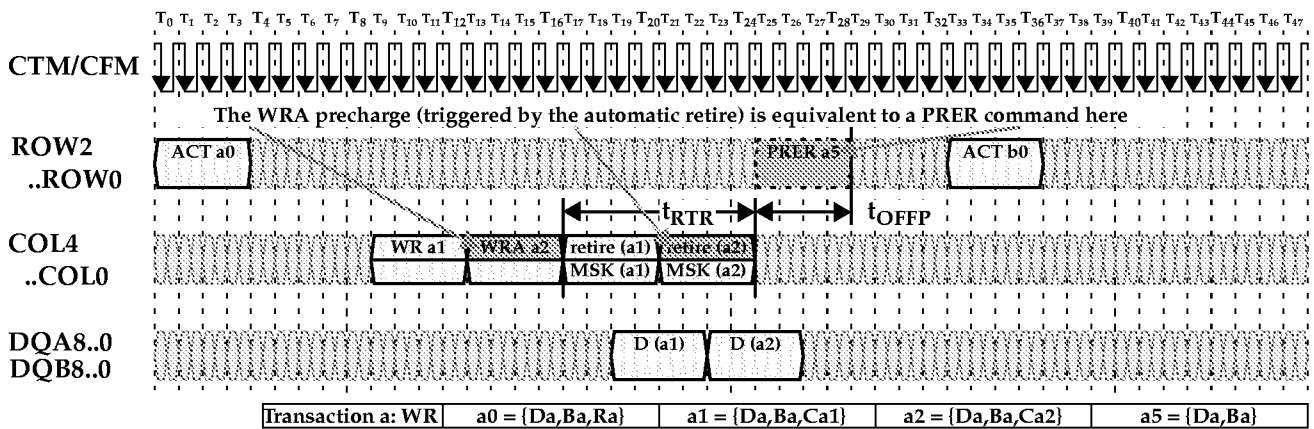

**COLX Packet: PREX Precharge Offset**

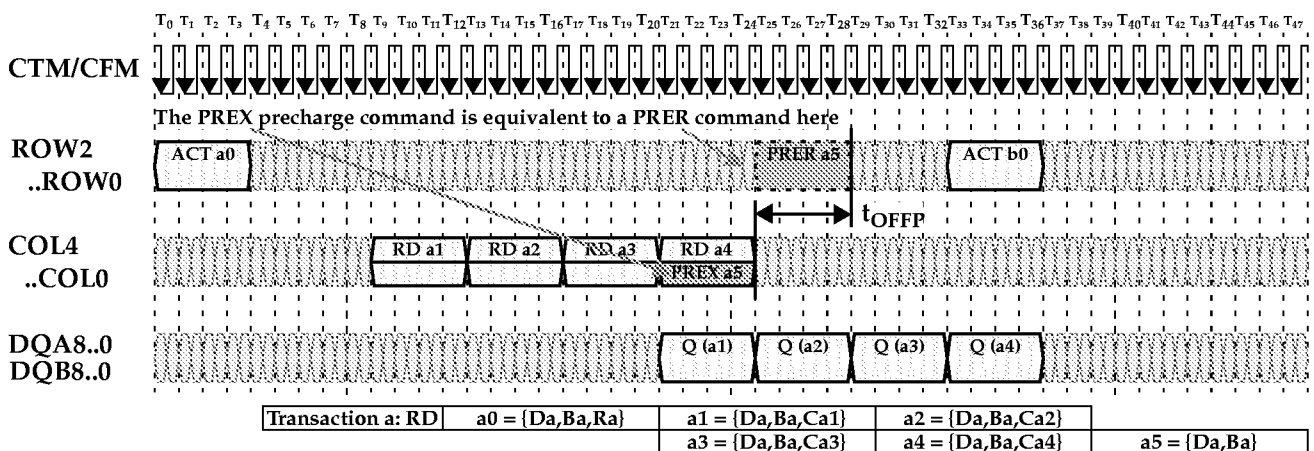

Figure 14: Offsets for Alternate Precharge Mechanisms

### Read Transaction - Example

Figure 15 shows an example of a read transaction. It begins by activating a bank with an ACT a0 command in an ROWA packet. A time  $t_{RCD}$  later a RD a1 command is issued in a COLC packet. Note that the ACT command includes the device, bank, and row address (abbreviated as a0) while the RD command includes device, bank, and column address (abbreviated as a1). A time  $t_{CAC}$  after the RD command the read data dualoct Q(a1) is returned by the device. Note that the packets on the ROW and COL pins use the end of the packet as a timing reference point, while the packets on the DQA/DQB pins use the beginning of the packet as a timing reference point.

A time  $t_{CC}$  after the first COLC packet on the COL pins a second is issued. It contains a RD a2 command. The a2 address has the same device and bank address as the a1 address (and a0 address), but a different column address. A time  $t_{CAC}$  after the second RD command a second read data dualoct Q(a2) is returned by the device.

Next, a PRER a3 command is issued in an ROWR packet on the ROW pins. This causes the bank to precharge so that a different row may be activated in a subsequent transaction or so that an adjacent bank may be activated. The a3 address includes the same

device and bank address as the a0, a1, and a2 addresses. The PRER command must occur a time  $t_{RAS}$  or more after the original ACT command (the activation operation in any DRAM is destructive, and the contents of the selected row must be restored from the two associated sense amps of the bank during the  $t_{RAS}$  interval). The PRER command must also occur a time  $t_{RDP}$  or more after the last RD command. Note that the  $t_{RDP}$  value shown is greater than the  $t_{RDP,MIN}$  specification in Table 22. This transaction example reads two dualocts, but there is actually enough time to read three dualocts before  $t_{RDP}$  becomes the limiting parameter rather than  $t_{RAS}$ . If four dualocts were read, the packet with PRER would need to shift right (be delayed) by one  $t_{CYCLE}$  (note - this case is not shown).

Finally, an ACT b0 command is issued in an ROWR packet on the ROW pins. The second ACT command must occur a time  $t_{RC}$  or more after the first ACT command and a time  $t_{RP}$  or more after the PRER command. This ensures that the bank and its associated sense amps are precharged. This example assumes that the second transaction has the same device and bank address as the first transaction, but a different row address. Transaction b may not be started until transaction a has finished. However, transactions to other banks or other devices may be issued during transaction a.

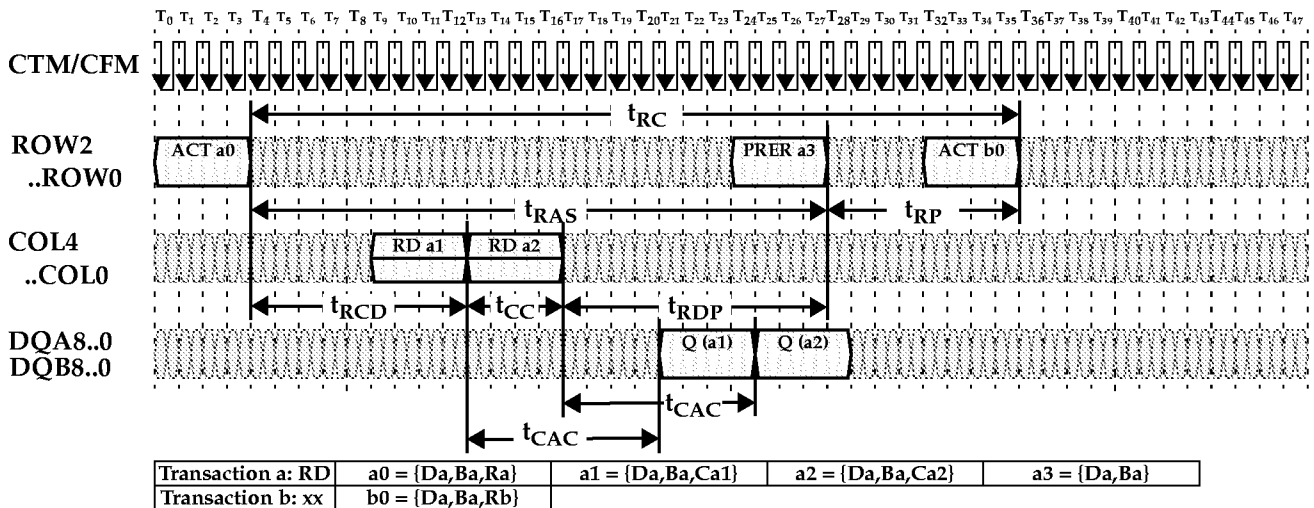

Figure 15: Read Transaction Example

### Write Transaction - Example

Figure 16 shows an example of a write transaction. It begins by activating a bank with an ACT a0 command in an ROWA packet. A time  $t_{RCD}$  later a WR a1 command is issued in a COLC packet. Note that the ACT command includes the device, bank, and row address (abbreviated as a0) while the WR command includes device, bank, and column address (abbreviated as a1). A time  $t_{CWD}$  after the WR command the write data dualoct D(a1) is issued. Note that the packets on the ROW and COL pins use the end of the packet as a timing reference point, while the packets on the DQA/DQB pins use the beginning of the packet as a timing reference point.

A time  $t_{CC}$  after the first COLC packet on the COL pins a second COLC packet is issued. It contains a WR a2 command. The a2 address has the same device and bank address as the a1 address (and a0 address), but a different column address. A time  $t_{CWD}$  after the second WR command a second write data dualoct D(a2) is issued.

A time  $t_{RTR}$  after each WR command an optional COLM packet MSK (a1) is issued, and at the same time a COLC packet is issued causing the write buffer to automatically retire. See Figure 17 for more detail on the write/retire mechanism. If a COLM packet is not used, all data bytes are unconditionally written. If the COLC packet which causes the write buffer to retire is

delayed, then the COLM packet (if used) must also be delayed.

Next, a PRER a3 command is issued in an ROWR packet on the ROW pins. This causes the bank to precharge so that a different row may be activated in a subsequent transaction or so that an adjacent bank may be activated. The a3 address includes the same device and bank address as the a0, a1, and a2 addresses. The PRER command must occur a time  $t_{RAS}$  or more after the original ACT command (the activation operation in any DRAM is destructive, and the contents of the selected row must be restored from the two associated sense amps of the bank during the  $t_{RAS}$  interval).

A PRER a3 command is issued in an ROWR packet on the ROW pins. The PRER command must occur a time  $t_{RTP}$  or more after the last COLC which causes an automatic retire.

Finally, an ACT b0 command is issued in an ROWR packet on the ROW pins. The second ACT command must occur a time  $t_{RC}$  or more after the first ACT command and a time  $t_{RP}$  or more after the PRER command. This ensures that the bank and its associated sense amps are precharged. This example assumes that the second transaction has the same device and bank address as the first transaction, but a different row address. Transaction b may not be started until transaction a has finished. However, transactions to other banks or other devices may be issued during transaction a.

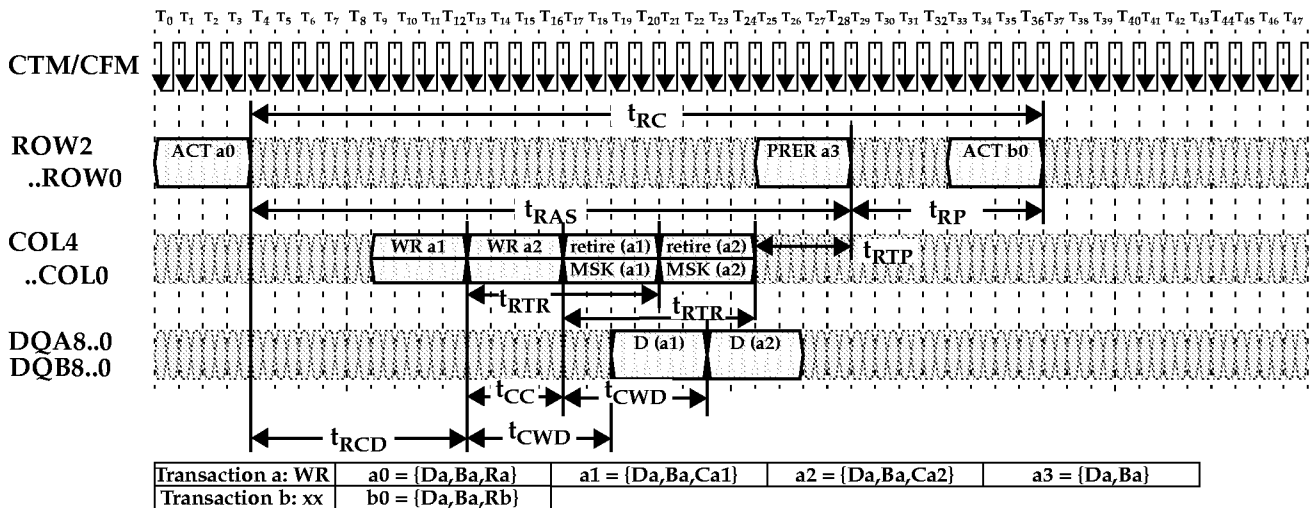

Figure 16: Write Transaction Example

**Write/Retire - Examples**

The process of writing a dualoct into a sense amp of an RDRAM bank occurs in two steps. The first step consists of transporting the write command, write address, and write data into the write buffer. The second step happens when the RDRAM automatically retires the write buffer (with an optional bytemask) into the sense amp. This two-step write process reduces the natural turn-around delay due to the internal bidirectional data pins.

Figure 17 (left) shows an example of this two step process. The first COLC packet contains the WR command and an address specifying device, bank and column. The write data dualoct follows a time  $t_{CWD}$  later. This information is loaded into the write buffer of

the specified device. The COLC packet which follows a time  $t_{RTR}$  later will retire the write buffer. The retire will happen automatically unless (1) a COLC packet is not framed (no COLC packet is present and the S bit is zero), or (2) the COLC packet contains a RD command to the same device. If the retire does not take place at time  $t_{RTR}$  after the original WR command, then the device continues to frame COLC packets, looking for the first that is not a RD directed to itself. A bytemask MSK(a1) may be supplied in a COLM packet aligned with the COLC that retires the write buffer at time  $t_{RTR}$  after the WR command.

The memory controller must be aware of this two-step write/retire process. Controller performance can be improved, but only if the controller design accounts for several side effects.

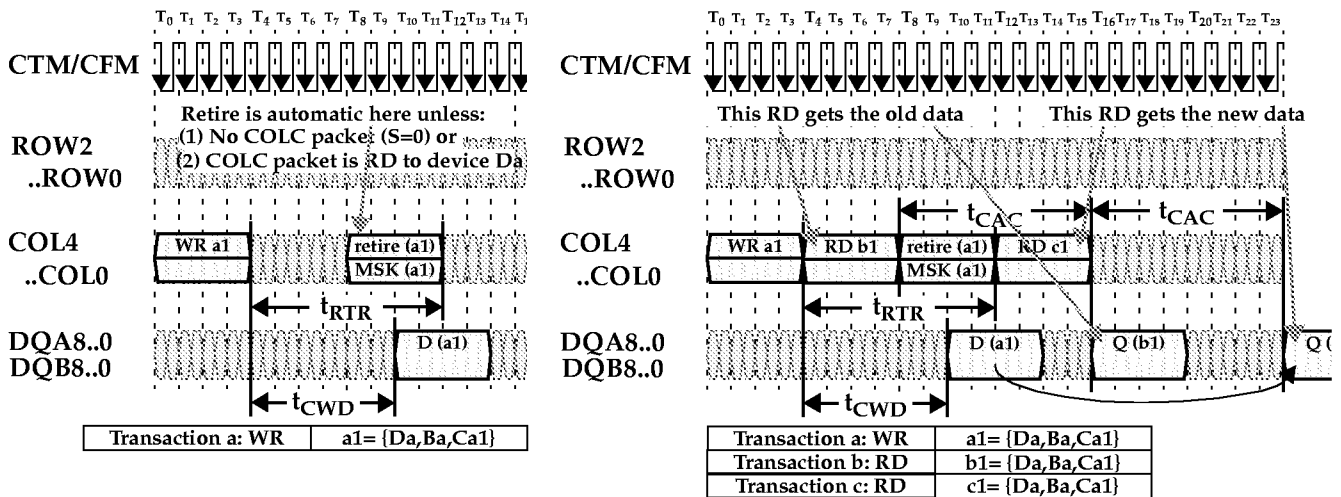

**Figure 17: Normal Retire (left) and Retire/Read Ordering (right)**

Figure 17 (right) shows the first of these side effects. The first COLC packet has a WR command which loads the address and data into the write buffer. The third COLC causes an automatic retire of the write buffer to the sense amp. The second and fourth COLC packets (which bracket the retire packet) contain RD commands with the same device, bank and column address as the original WR command. In other words, the same dualoct address that is written is read both before and after it is actually retired. The first RD returns the old dualoct value from the sense amp before it is overwritten. The second RD returns the new dualoct value that was just written.

Figure 18 (left) shows the result of performing a RD command to the same device in the same COLC packet slot that would normally be used for the retire opera-

tion. The read may be to any bank and column address; all that matters is that it is to the same device as the WR command. The retire operation and MSK(a1) will be delayed by a time  $t_{PACKET}$  as a result. If the RD command used the same bank and column address as the WR command, the old data from the sense amp would be returned. If many RD commands to the same device were issued instead of the single one that is shown, then the retire operation would be held off an arbitrarily long time. However, once a RD to another device or a WR or NOCOP to any device is issued, the retire will take place. Figure 18 (right) illustrates a situation in which the controller wants to issue a WR-WR-RD COLC packet sequence, with all commands addressed to the same device, but addressed to any combination of banks and columns.



### Interleaved Write - Example

Figure 20 shows an example of an interleaved write transaction. Transactions similar to the one presented in Figure 16 are directed to non-adjacent banks of a single RDRAM. This allows a new transaction to be issued once every  $t_{RR}$  interval rather than once every  $t_{RC}$  interval (four times more often). The DQ data pin efficiency is 100% with this sequence.

With two dualocts of data written per transaction, the COL, DQA, and DQB pins are fully utilized. Banks are precharged using the WRA autoprecharge option

rather than the PRER command in an ROWR packet on the ROW pins.

In this example, the first transaction is directed to device Da and bank Ba. The next three transactions are directed to the same device Da, but need to use different, non-adjacent banks Bb, Bc, Bd so there is no bank conflict. The fifth transaction could be redirected back to bank Ba without interference, since the first transaction would have completed by then ( $t_{RC}$  has elapsed). Each transaction may use any value of row address (Ra, Rb, ..) and column address (Ca1, Ca2, Cb1, Cb2, ...).

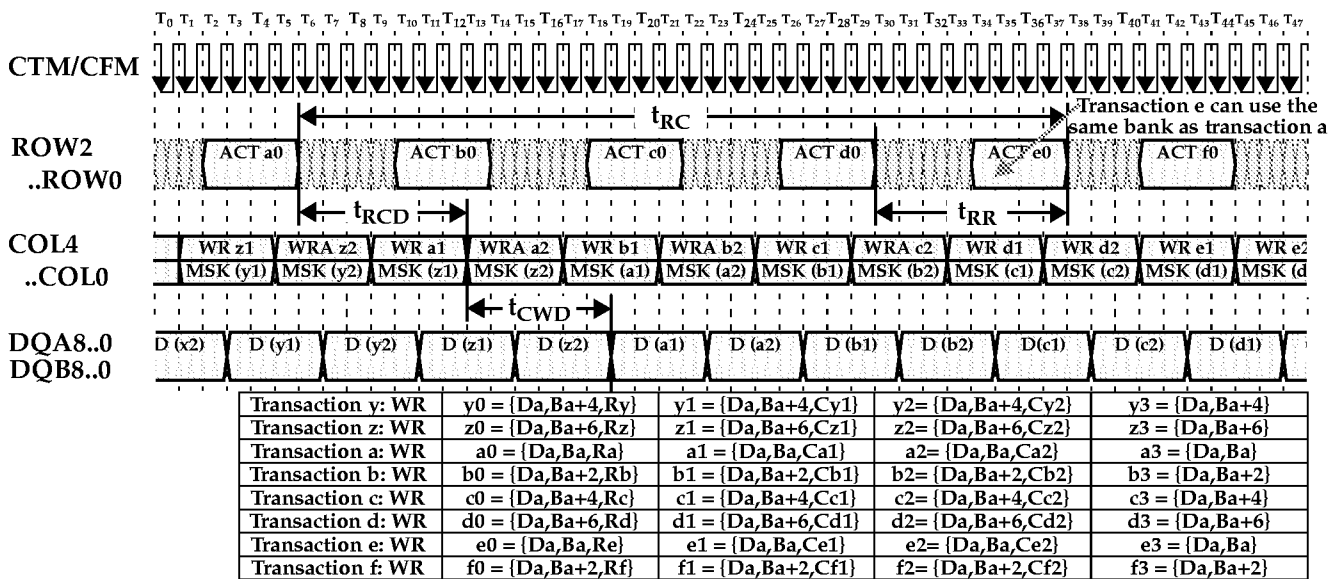

Figure 20: Interleaved Write Transaction with Two Dualoct Data Length

### Interleaved Read - Example

Figure 21 shows an example of interleaved read transactions. Transactions similar to the one presented in Figure 15 are directed to non-adjacent banks of a single RDRAM. The address sequence is identical to the one used in the previous write example. The DQ data pins efficiency is also 100%. The only difference with the write example (aside from the use of the RD command rather than the WR command) is the use of the PREX command in a COLX packet to precharge the banks rather than the RDA command. This is done because the PREX is available for a readtransaction but is not available for a masked write transaction.

cent banks of a single RDRAM. This is similar to the interleaved write and read examples in Figure 20 and Figure 21 except that bubble cycles need to be inserted by the controller at read/write boundaries. The DQ data pin efficiency for the example in Figure 22 is 32/38 or 84%. If there were more RDRAMs on the Channel, the DQ pin efficiency would approach 32/34 or 94% for the two-dualoct RRWW sequence (this case is not shown).

### Interleaved RRWW - Example

Figure 22 shows a steady-state sequence of 2-dualoct RD/RD/WR/WR.. transactions directed to non-adjacent

In Figure 22, the first bubble type  $t_{CBUB1}$  is inserted by the controller between a RD and WR command on the COL pins. This bubble accounts for the round-trip propagation delay that is seen by read data, and is explained in detail in Figure 4. This bubble appears on the DQA and DQB pins as  $t_{DBUB1}$  between a write data dualoct D and read data dualoct Q. This bubble also appears on the ROW pins as  $t_{RBUB1}$ .

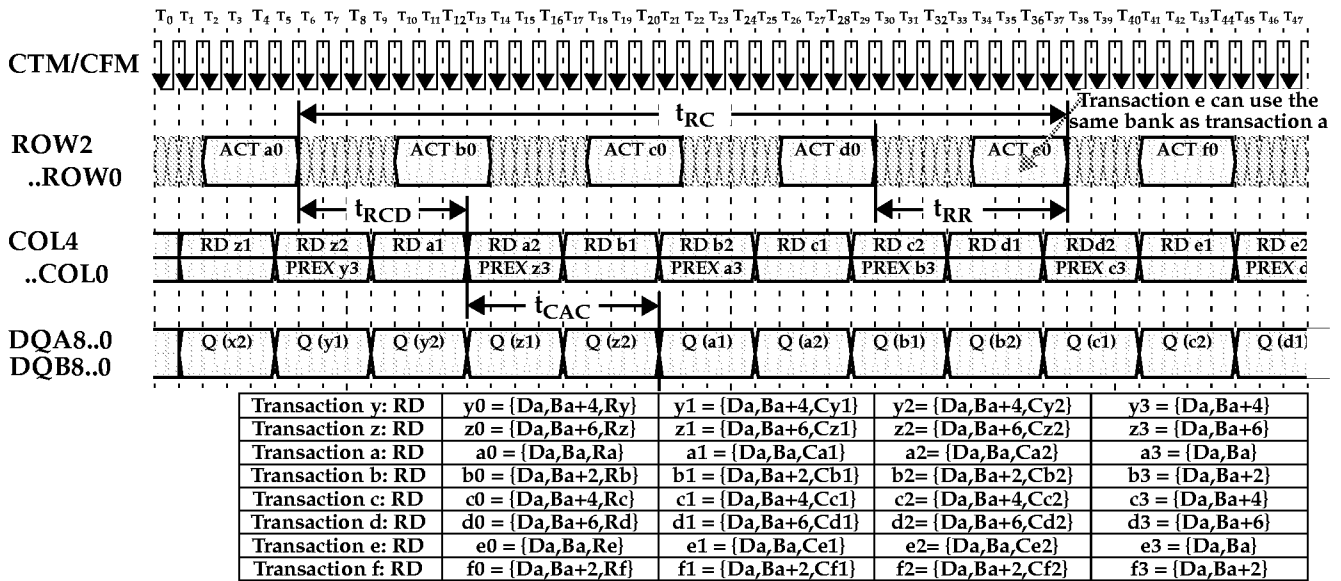

Figure 21: Interleaved Read Transaction with Two Dualoct Data Length

The second bubble type  $t_{CBUB2}$  is inserted (as a NOCOP command) by the controller between a WR and RD command on the COL pins when there is a WR-WR-RD sequence to the same device. This bubble enables write data to be retired from the write buffer without being lost, and is explained in detail in

Figure 18. There would be no bubble if address c0 and address d0 were directed to different devices. This bubble appears on the DQA and DQB pins as  $t_{DBUB2}$  between a write data dualoct D and read data dualoct Q. This bubble also appears on the ROW pins as  $t_{RBUB2}$ .

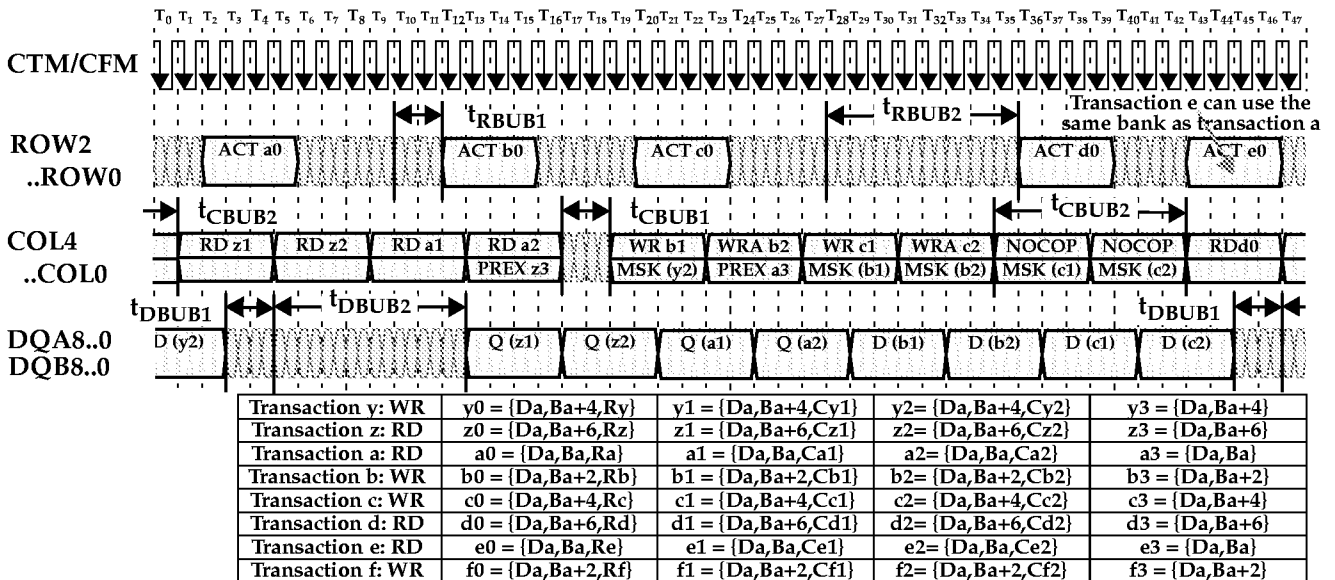

Figure 22: Interleaved RRWW Sequence with Two Dualoct Data Length

### Control Register Transactions

The RDRAM has two CMOS input pins SCK and CMD and two CMOS input/output pins SIO0 and SIO1. These provide serial access to a set of control registers in the RDRAM. These control registers provide configuration information to the controller during the initialization process. They also allow an application to select the appropriate operating mode of the RDRAM.

SCK (serial clock) and CMD (command) are driven by the controller to all RDRAMs in parallel. SIO0 and SIO1 are connected (in a daisy chain fashion) from one RDRAM to the next. In normal operation, the data on SIO0 is repeated on SIO1, which connects to SIO0 of the next RDRAM (the data is repeated from SIO1 to SIO0 for a read data packet). The controller connects to SIO0 of the first RDRAM.

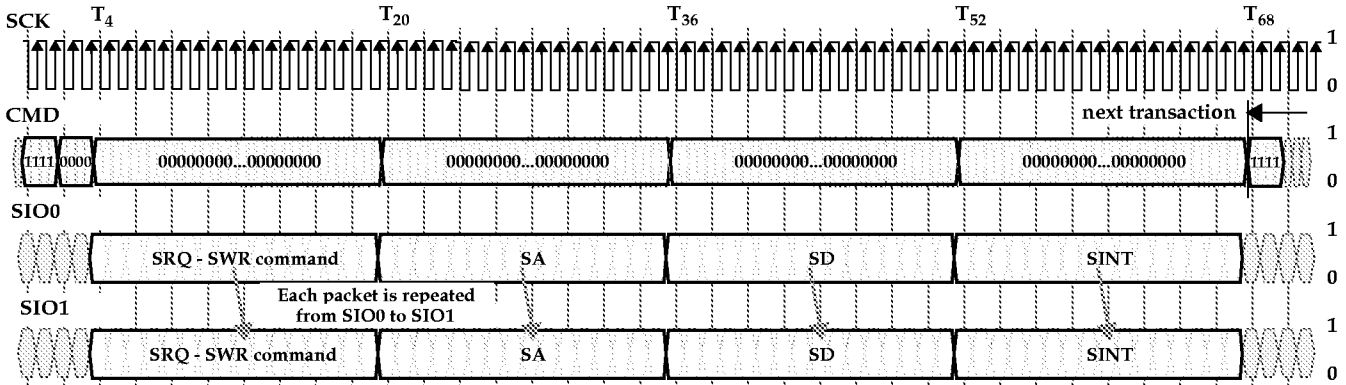

Figure 23: Serial Write (SWR) Transaction to Control Register

Write and read transactions are each composed of four packets, as shown in Figure 23 and Figure 24. Each packet consists of 16 bits, as summarized in Table 14 and Table 15. The packet bits are sampled on the falling edge of SCK. A transaction begins with a SRQ (Serial Request) packet. This packet is framed with a 11110000 pattern on the CMD input (note that the CMD bits are sampled on both the falling edge and the rising edge of SCK). The SRQ packet contains the SOP3..SOP0 (Serial Opcode) field, which selects the transaction type. The SDEV4..SDEV0 (Serial Device address) selects one of the 32 RDRAMs. If SBC (Serial Broadcast) is set, then all RDRAMs are selected. The SA (Serial Address)

packet contains a 12 bit address for selecting a control register.

A write transaction has a SD (Serial Data) packet next. This contains 16 bits of data that is written into the selected control register. A SINT (Serial Interval) packet is last, providing some delay for any side-effects to take place. A read transaction has a SINT packet, then a SD packet. This provides delay for the selected RDRAM to access the control register. The SD read data packet travels in the opposite direction (towards the controller) from the other packet types. The SCK cycle time will accommodate the total delay.

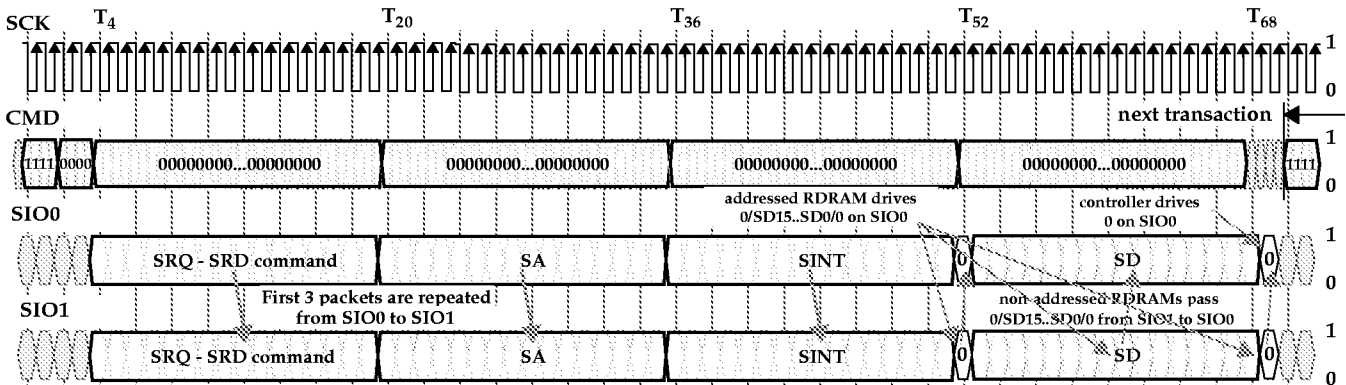

Figure 24: Serial Read (SRD) Transaction Control Register

### Control Register Packets

Table 14 summarizes the formats of the four packet types for control register transactions. Table 15 summarizes the fields that are used within the packets.

Figure 25 shows the transaction format for the SETR, CLRR, and SETF commands. These transactions consist of a single SRQ packet, rather than four packets like the SWR and SRD commands. The same framing sequence on the CMD input is used, however. These commands are used during initialization prior to any control register read or write transactions.

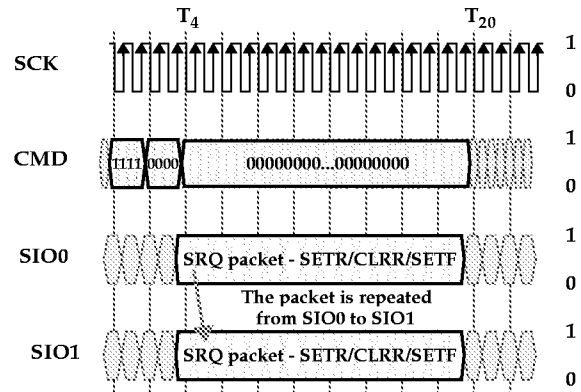

Figure 25: SETR, CLRR,SETF Transaction

Table 14: Control Register Packet Formats

SCK Cycle	SIO0 or SIO1 for SRQ	SIO0 or SIO1 for SA	SIO0 or SIO1 for SINT	SIO0 or SIO1 for SD	SCK Cycle	SIO0 or SIO1 for SRQ	SIO0 or SIO1 for SA	SIO0 or SIO1 for SINT	SIO0 or SIO1 for SD
0	rsrv	rsrv	0	SD15	8	SOP1	SA7	0	SD7
1	rsrv	rsrv	0	SD14	9	SOP0	SA6	0	SD6
2	rsrv	rsrv	0	SD13	10	SBC	SA5	0	SD5
3	rsrv	rsrv	0	SD12	11	SDEV4	SA4	0	SD4
4	rsrv	SA11	0	SD11	12	SDEV3	SA3	0	SD3
5	SDEV5	SA10	0	SD10	13	SDEV2	SA2	0	SD2
6	SOP3	SA9	0	SD9	14	SDEV1	SA1	0	SD1
7	SOP2	SA8	0	SD8	15	SDEV0	SA0	0	SD0

Table 15: Field Description for Control Register Packets

Field	Description
rsrv	Reserved. Should be driven as “0” by controller.
SOP3..SOP0	0000 - SRD. Serial read of control register {SA11..SA0} of RDRAM {SDEV5..SDEV0}. 0001 - SWR. Serial write of control register {SA11..SA0} of RDRAM {SDEV5..SDEV0}. 0010 - SETR. Set Reset bit, all control registers assume their reset values. <sup>a</sup> 16 t <sub>SCYCLE</sub> delay until CLRR command. 0100 - SETF. Set fast (normal) clock mode. 1011 - CLRR. Clear Reset bit, all control registers retain their reset values. <sup>a</sup> 4 t <sub>SCYCLE</sub> delay until next command. 1111 - NOP. No serial operation. 0011, 0101-1010, 1100-1110 - RSRV. Reserved encodings.
SDEV5..SDEV0	Serial device. Compared to SDEVID5..SDEVID0 field of INIT control register field to select the RDRAM to which the transaction is directed.
SBC	Serial broadcast. When set, RDRAMs ignore {SDEV5..SDEV0} for RDRAM selection.
SA11..SA0	Serial address. Selects which control register of the selected RDRAM is read or written.
SD15..SD0	Serial data. The 16 bits of data written to or read from the selected control register of the selected RDRAM.

a. The SETR and CLRR commands must always be applied in two successive transactions to RDRAMs; i.e. they may not be used in isolation. This is called “SETR/CLRR Reset”.

Initialization

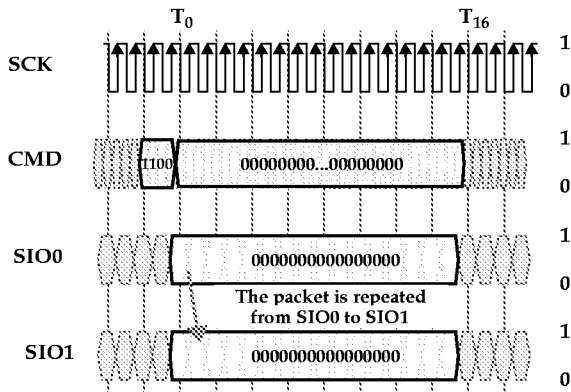

Figure 26: SIO Reset Sequence

Initialization refers to the process that a controller must go through after power is applied to the system or the system is reset. The controller prepares the RDRAM sub-system for normal Channel operation by using a sequence of control register transactions on the serial CMOS pins.

The first step in this sequence is to assign unique serial device addresses to all the RDRAMs. This is done with Algorithm InitDev, shown in the opposite column. The controller assumes that there are no more than “N” RDRAMs on the Channel (the Channel maximum is 32, but some applications may have a lower limit).

First, the SIO0 and SIO1 pin directionality is established with the sequence in step 1. The controller then resets all RDRAMs, using broadcast SETR and CLRR commands (steps 2,3,4) with a delay in between (this is also called SIO Reset). In step 5, a SETF command establishes the normal clock frequency. See Figure 25 for the format of SETR, CLRR, and SETF transactions. In step 6 the SIO0-to-SIO1 link is broken in all RDRAMs, so the controller is only talking to the first RDRAM. Also, the SDEVID field is set to its maximum value. Next, the loop index INDX is initialized (step 7). In step 8, the SDEVID field is loaded with the INDX value, and the SRP bit is set so the next RDRAM becomes accessible. In step 9, the INDX value is incremented, and in step 10, steps 8 and 9 are repeated for the remaining RDRAMs.

Finally, it will be necessary for the controller to force a 200µs pause interval to allow the RDRAM core timing circuits to stabilize. All banks of all RDRAMs must also be accessed twice. An access is an activate (ACT) and a

precharge (PRE) command. This may be accomplished with the refresh commands.

At this point, Algorithm InitDev is complete and all RDRAMs have a unique device address SDEVID5..0 for control register transactions. Note that the SDEVID address value of an RDRAM indicates its position in the daisy-chained CMOS serial pins. This will not necessarily be the same value as the DEVID register which is used for memory transactions. The next steps taken by the controller will vary depending upon the application, so only a rough outline can be given here.

=====  
Algorithm InitDev: Assign SDEVID Device Addresses

1. Issue SIO Pin Initialization sequence (see Figure 26).
2. Issue one SETR transaction:
  - SOP3..SOP0 = 0010 (SETR command)
  - SBC = 1 (Broadcast)
  - SDEV5..SDEV0 = 000000 (don't care).
3. Wait 16 SCK cycles.
4. Issue one CLRR transaction:
  - SOP3..SOP0 = 0011 (CLRR command)
  - SBC = 1 (Broadcast)
  - SDEV5..SDEV0 = 000000 (don't care).
5. Wait 4 SCK cycles.
6. Issue one SETF transaction:
  - SOP3..SOP0 = 0100 (SETF command)
  - SBC = 1 (Broadcast)
  - SDEV5..SDEV0 = 000000 (don't care).
7. Issue one register write transaction:
  - SOP3..SOP0 = 0001 (SWR command)
  - SBC = 1 (broadcast)
  - SDEV5..SDEV0 = 000000 (don't care).
  - SA11..SA0 = 021<sub>16</sub> (INIT control register).
  - SD15..SD0 = 401f<sub>16</sub> (SRP<=0, SDEVID<=3f).
8. Set INDX5..INDX0 to 000000<sub>2</sub>. INDX is a counter in the Controller which acts as a loop index.
9. Issue one register write transaction (SRP<=1, SDEVID<=INDX):
  - SOP3..SOP0 = 0001 (SWR command)
  - SBC = 0 (non-broadcast)
  - SDEV5..SDEV0 = 111111.
  - SA11..SA0 = 021<sub>16</sub> (INIT control register).
  - SD15..SD0 = {0<sub>2</sub>, INDX5, 00000100<sub>2</sub>, INDX4..INDX0}.
10. Increment INDX5..INDX0.
11. Repeat Steps (8) and (9) an additional (N-1) times.
12. t<sub>PAUSE</sub> delay, then t<sub>PDNxA</sub> + t<sub>PDNxB</sub> delay (to allow DLLs to lock), then access all banks twice (i.e. 32xREFA/REFP).

## **Initialization (continued)**

In essence, the controller must read all the read-only configuration registers of all RDRAMs, it must process this information, and then it must write all the read-write registers to place the RDRAMs into the proper operating mode. The most important of these read-write registers are DEVID (the device address for memory transactions) and TRDLY (which sets the delay value for memory read data).

This page is reserved for further initialization detail when that information becomes available.

## Control Register Summary

Table 16 summarizes the RDRAM control registers. Detail is provided for each control register in Figure 27 through Figure 43. Read-only bits which are shaded gray are unused and return zero. Read-write bits which are shaded gray are reserved and should always be written with zero. The RIMM SPD Application Note

(DL-0054) describes additional read-only configuration registers which are present on Direct RIMMs.

The state of the register fields are potentially affected by the IO Reset operation or the SETR/CLRR operation. This is indicated in the text accompanying each register diagram.

**Table 16: Control Register Summary**

SA11..SA0	Register	Field	read-write/ read-only	Description
021 <sub>16</sub>	INIT	SDEVID	read-write, 6 bits	Serial device ID. Device address for control register read/write.
		PSX	read-write, 1 bit	Power select exit. PDN/NAP exit with device addr on DQA5..0.
		SRP	read-write, 1 bit	SIO repeater. Used to initialize RDRAM.
		NSR	read-write, 1 bit	NAP self-refresh. Enables self-refresh in NAP mode.
		PSR	read-write, 1 bit	PDN self-refresh. Enables self-refresh in PDN mode.
		LSR	read-write, 1 bit	Low power self-refresh. Enables low power self-refresh.
		TEN	read-write, 1 bit	Temperature sensing enable. Enables low power self-refresh.
		TSQ	read-write, 1 bit	Temperature sensing output. Enables low power self-refresh.
		DIS	read-write, 1 bit	RDRAM disable.
022 <sub>16</sub>	TEST34	TEST34	read-write, 16 bits	Test register. Do not read or write after SIO reset.
023 <sub>16</sub>	CNFGA	REFBIT	read-only, 3 bit	Refresh bank bits. Used for multi-bank refresh.
		DBL	read-only, 1 bit	Double. Specifies doubled-bank architecture
		MVER	read-only, 6 bit	Manufacturer version. Manufacturer identification number.
		PVER	read-only, 6 bit	Protocol version. Specifies version of Direct protocol supported.
024 <sub>16</sub>	CNFGB	BYT	read-only, 1 bit	Byte. Specifies an 8-bit or 9-bit byte size.
		DEVTYP	read-only, 3 bit	Device type. Device can be RDRAM or some other device category.
		CORG	read-only, 6 bit	Core organization. Bank, row, column address field sizes.
		SVER	read-only, 6 bit	Stepping version. Mask version number.
040 <sub>16</sub>	DEVID	DEVID	read-write, 5 bits	Device ID. Device address for memory read/write.
041 <sub>16</sub>	REFB	REFB	read-write, 4 bits	Refresh bank. Next bank to be refreshed by self-refresh.
042 <sub>16</sub>	REFR	REFR	read-write, 9 bits	Refresh row. Next row to be refreshed by REFA, self-refresh.
043 <sub>16</sub>	CCA	CCA	read-write, 7 bits	Current control A. Controls I <sub>OL</sub> output current for DQA.
		ASYMA	read-write, 2 bits	Asymmetry control. Controls asymmetry of V <sub>OL</sub> /V <sub>OH</sub> swing for DQA.
044 <sub>16</sub>	CCB	CCB	read-write, 7 bits	Current control B. Controls I <sub>OL</sub> output current for DQB.
		ASYMB	read-write, 2 bits	Asymmetry control. Controls asymmetry of V <sub>OL</sub> /V <sub>OH</sub> swing for DQB.
045 <sub>16</sub>	NAPX	NAPXA	read-write, 5 bits	NAP exit. Specifies length of NAP exit phase A.
		NAPX	read-write, 5 bits	NAP exit. Specifies length of NAP exit phase A + phase B.
		DQS	read-write, 1 bits	DQ select. Selects CMD framing for NAP/PDN exit.
046 <sub>16</sub>	PDNXA	PDNXA	read-write, 13 bits	PDN exit. Specifies length of PDN exit phase A.
047 <sub>16</sub>	PDNX	PDNX	read-write, 13 bits	PDN exit. Specifies length of PDN exit phase A + phase B.
048 <sub>16</sub>	TPARM	TCAS	read-write, 2 bits	t <sub>CAS-C</sub> core parameter. Determines t <sub>OFFP</sub> datasheet parameter.
		TCLS	read-write, 2 bits	t <sub>CLS-C</sub> core parameter. Determines t <sub>CAC</sub> and t <sub>OFFP</sub> parameters.
		TCDLY0	read-write, 3 bits	t <sub>CDLY0-C</sub> core parameter. Programmable delay for read data.

Table 16: Control Register Summary

SA11..SA0	Register	Field	read-write/ read-only	Description
049 <sub>16</sub>	TFRM	TFRM	read-write, 4 bits	$t_{FRM-C}$ core parameter. Determines ROW-COL packet framing interval.
04a <sub>16</sub>	TCDLY1	TCDLY1	read-write, 3 bits	$t_{CDLY1-C}$ core parameter. Programmable delay for read data.
04c <sub>16</sub>	TCYCLE	TCYCLE	read-write, 14 bits	$t_{CYCLE}$ datasheet parameter. Specifies cycle time in 64ps units.
04b <sub>16-</sub>	TEST75	TEST75	read-write, 16 bits	Test register. Do not read or write after SIO reset.
04d <sub>16-</sub>	TEST77	TEST77	read-write, 16 bits	Test register. Write with zero after SIO reset.
04e <sub>16-</sub>	TEST78	TEST78	read-write, 16 bits	Test register. Do not read or write after SIO reset.
04f <sub>16-</sub>	TEST79	TEST79	read-write, 16 bits	Test register. Do not read or write after SIO reset.
080 <sub>16</sub> - 0ff <sub>16</sub>	reserved	reserved	vendor-specific	Vendor-specific test registers. Do not read or write after SIO reset.

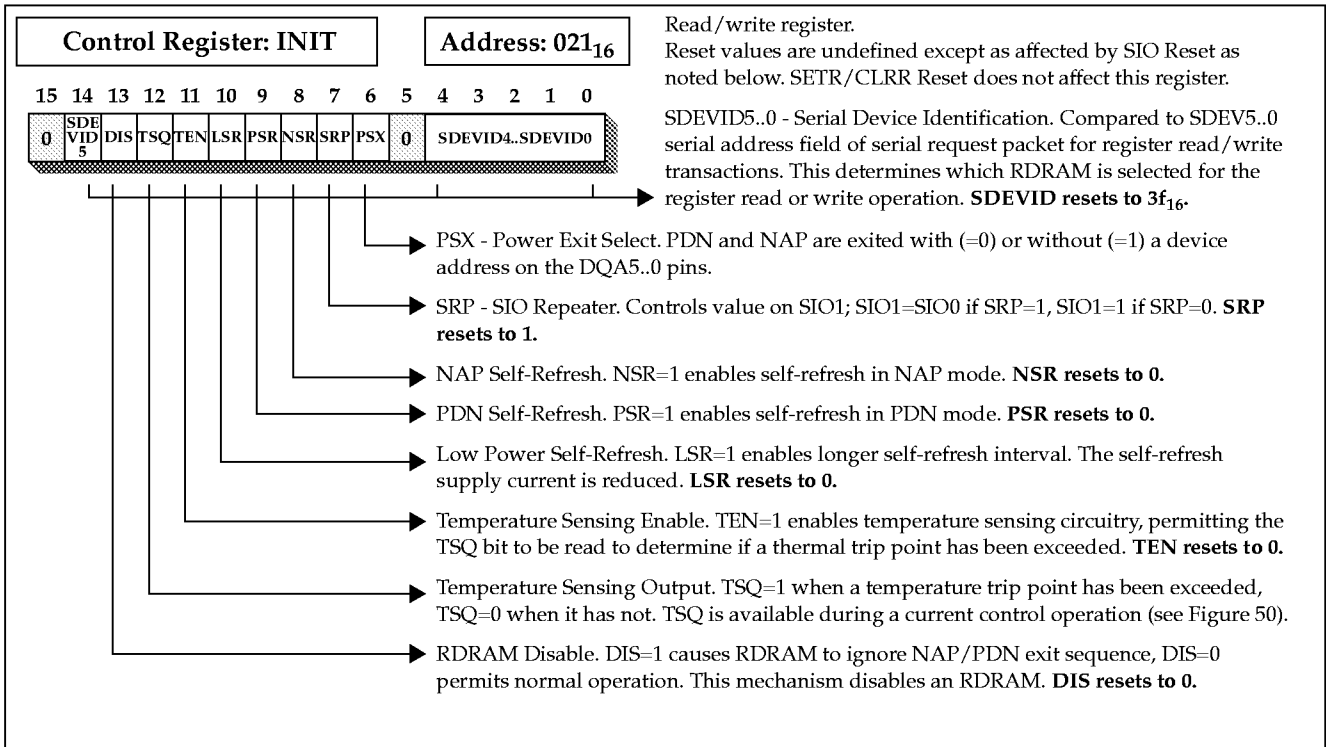

Figure 27: INIT Register

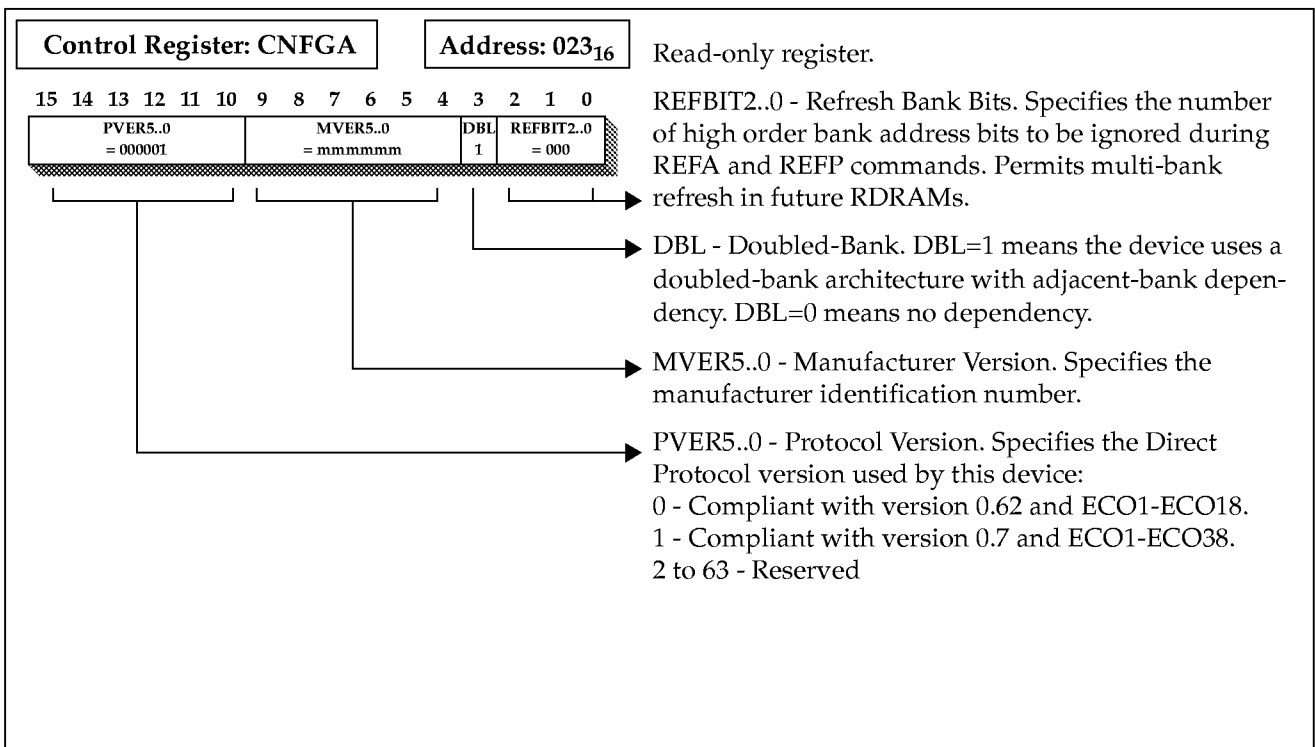

Figure 28: CNFGA Register

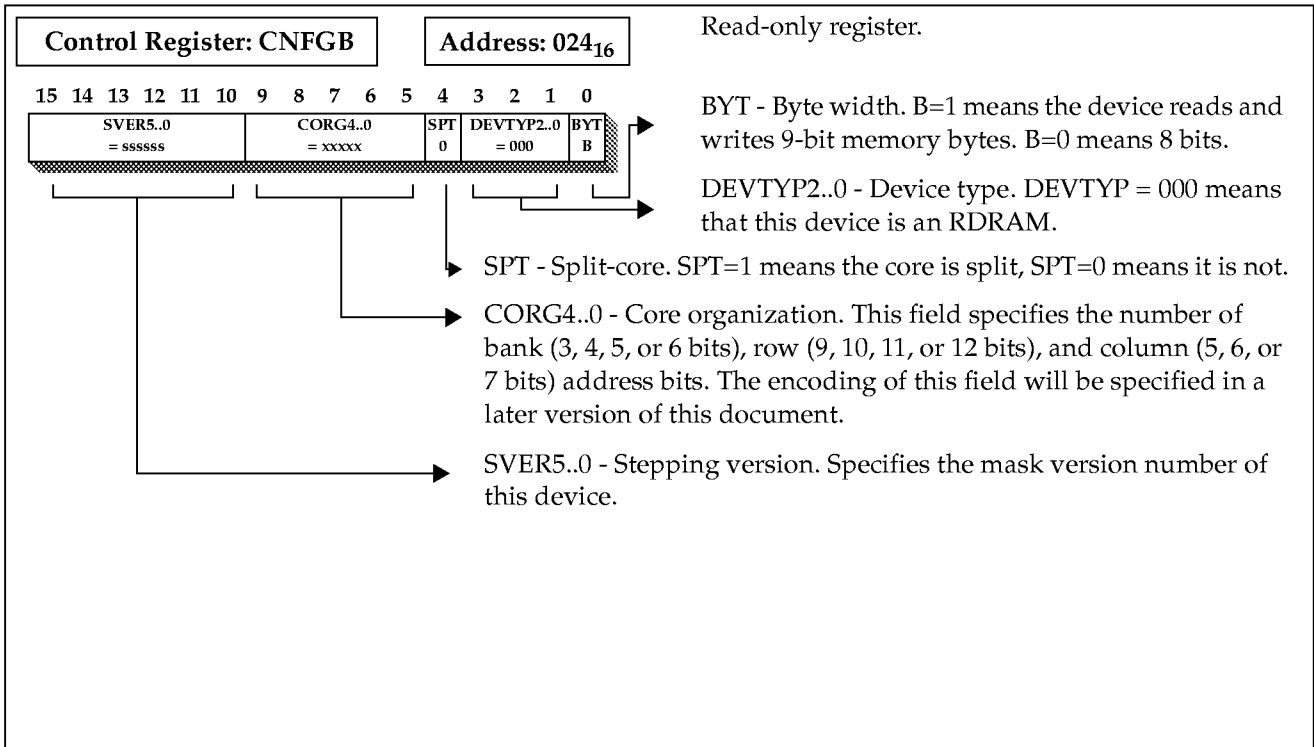

Figure 29: CNFGB Register

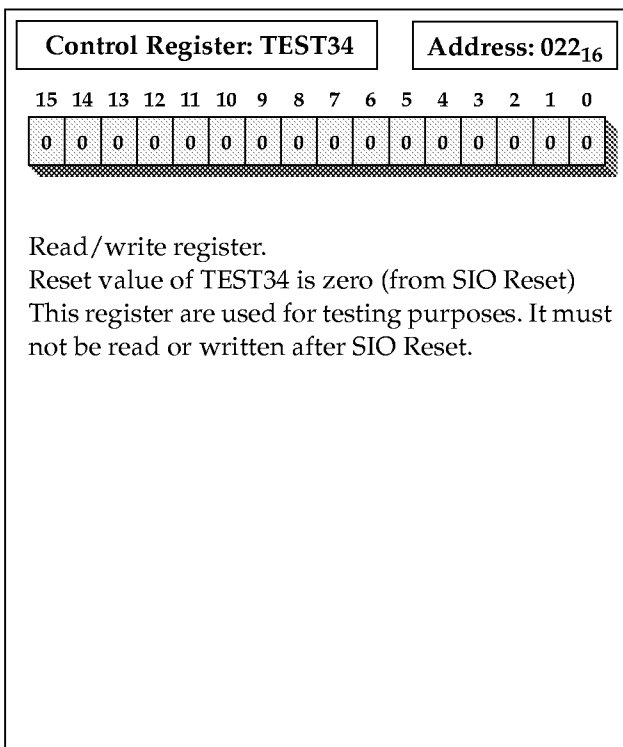

Figure 30: TEST Register

Figure 31: DEVID Register

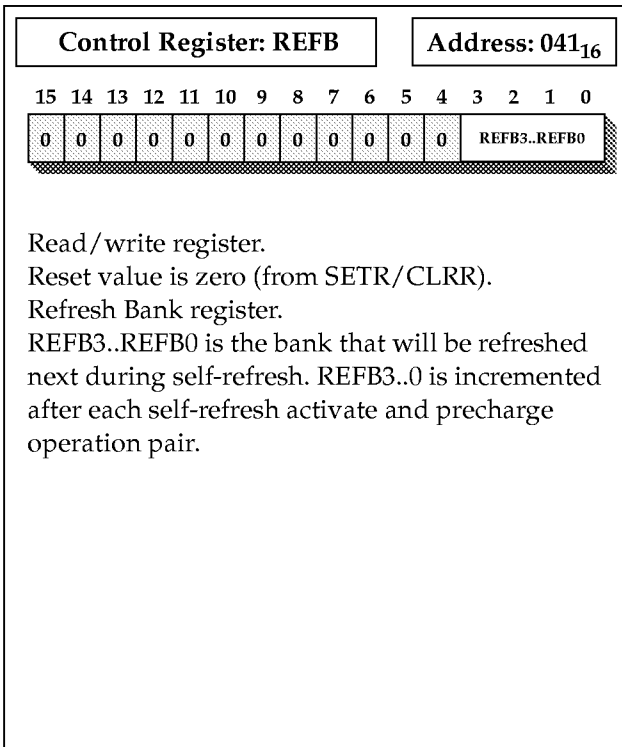

Figure 32: REFB Register

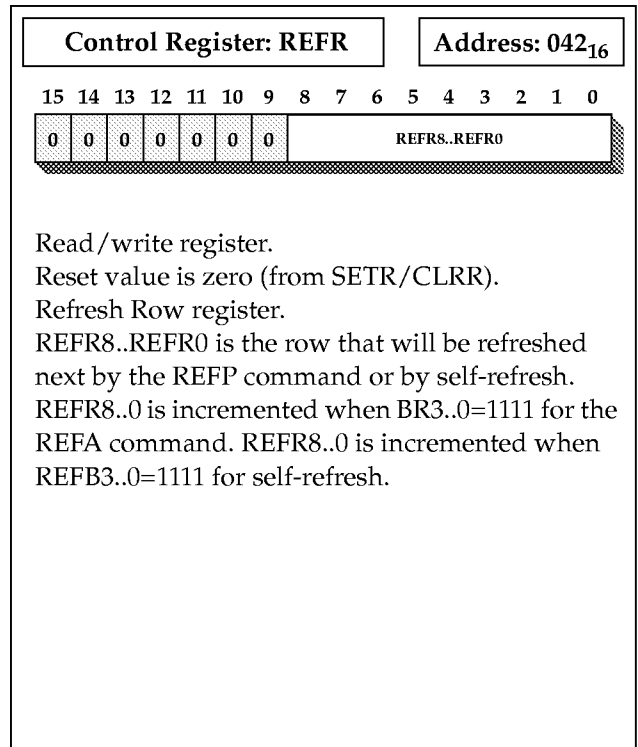

Figure 34: REFR Register

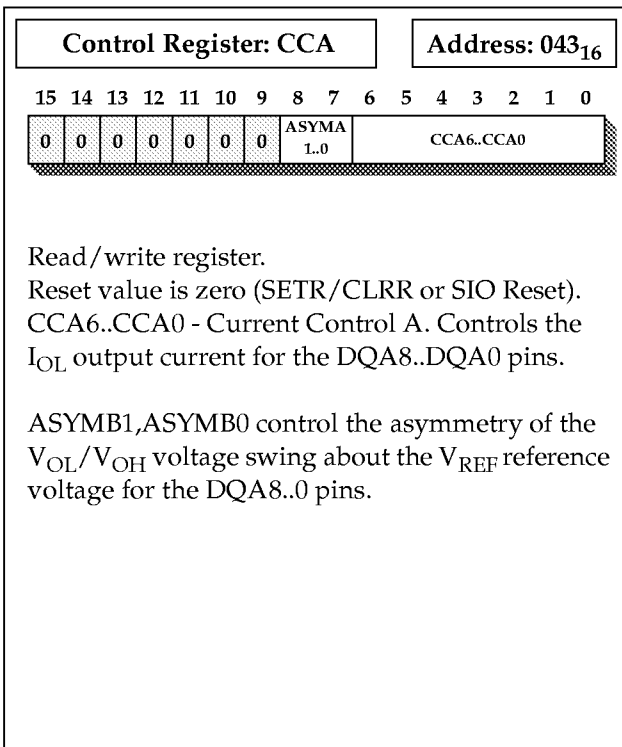

Figure 33: CCA Register

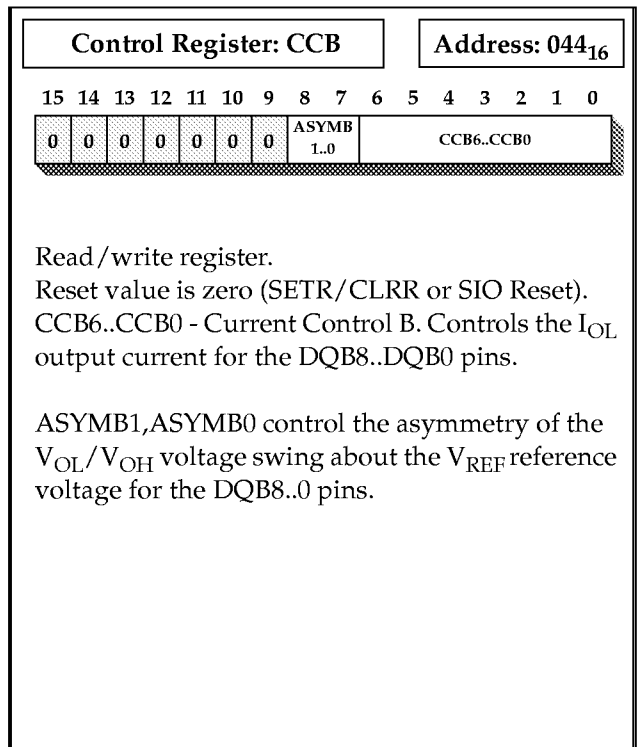

Figure 35: CCB Register

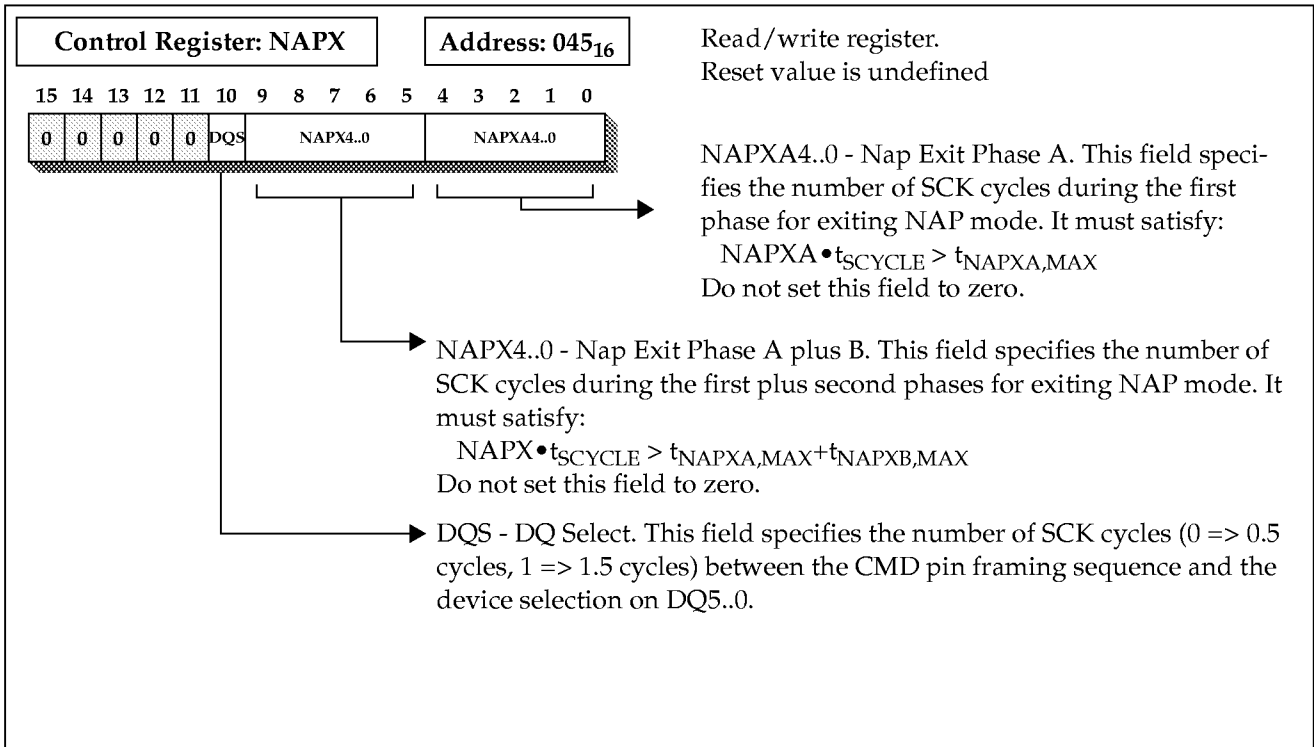

Figure 36: NAPX Register

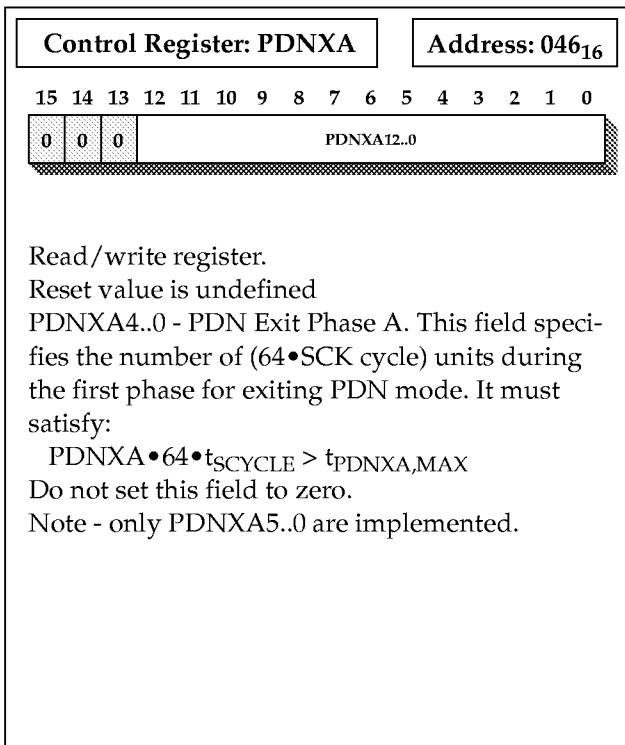

Figure 37: PDNXA Register

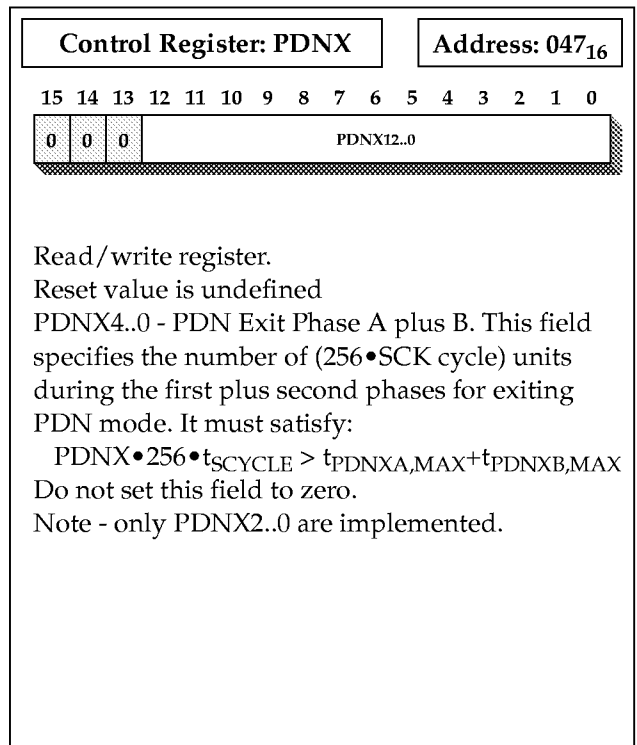

Figure 38: PDNX Register

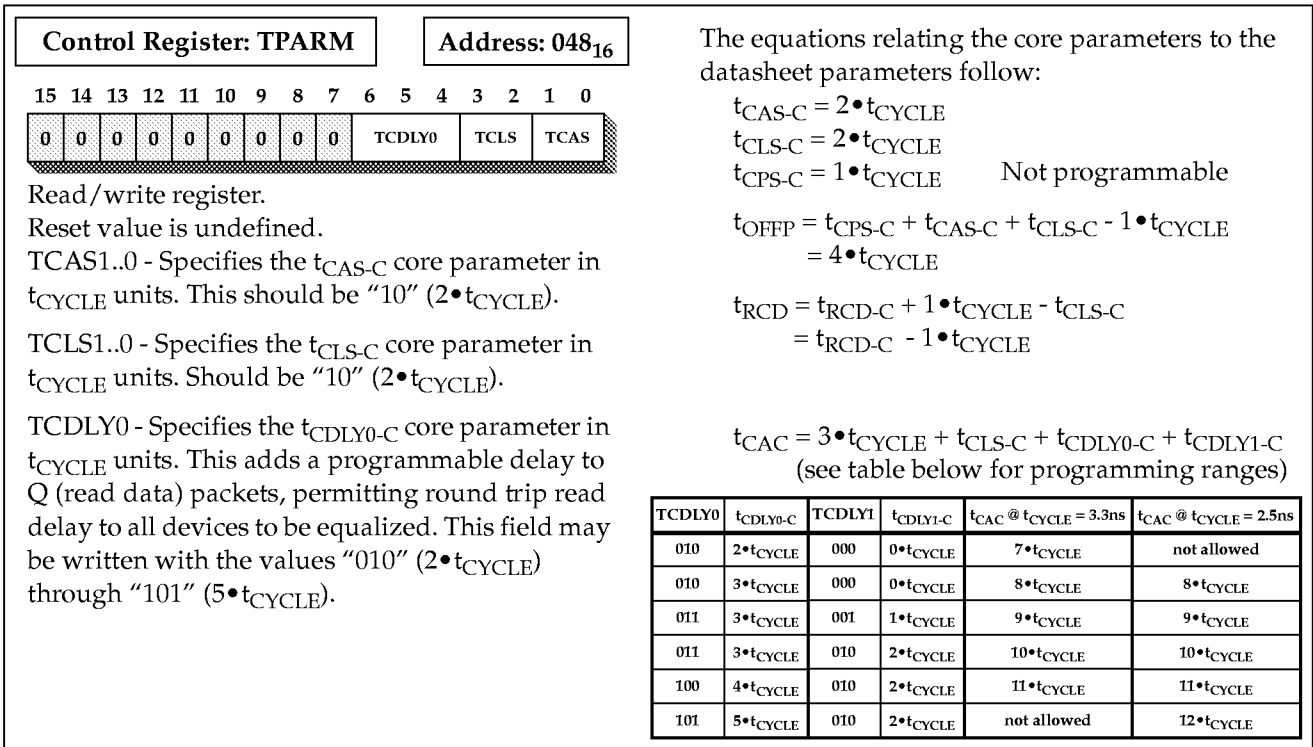

Figure 39: TPARM Register

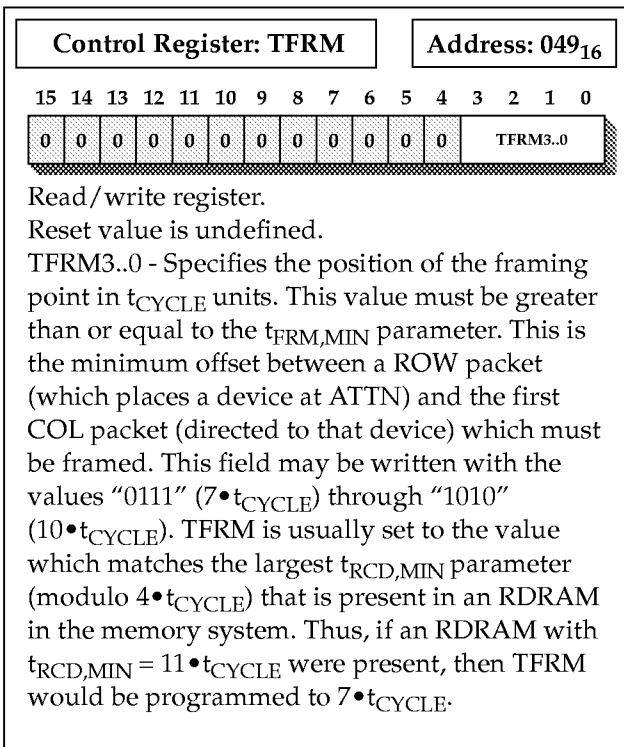

Figure 40: TFRM Register

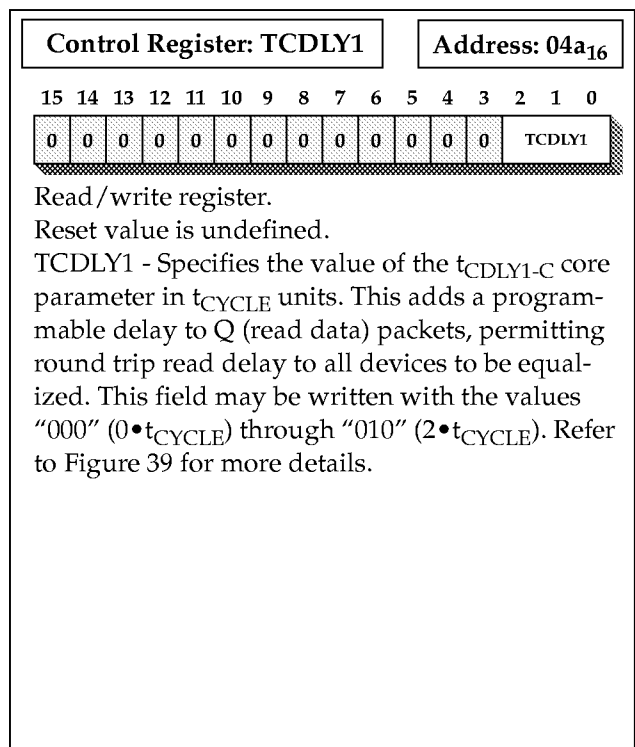
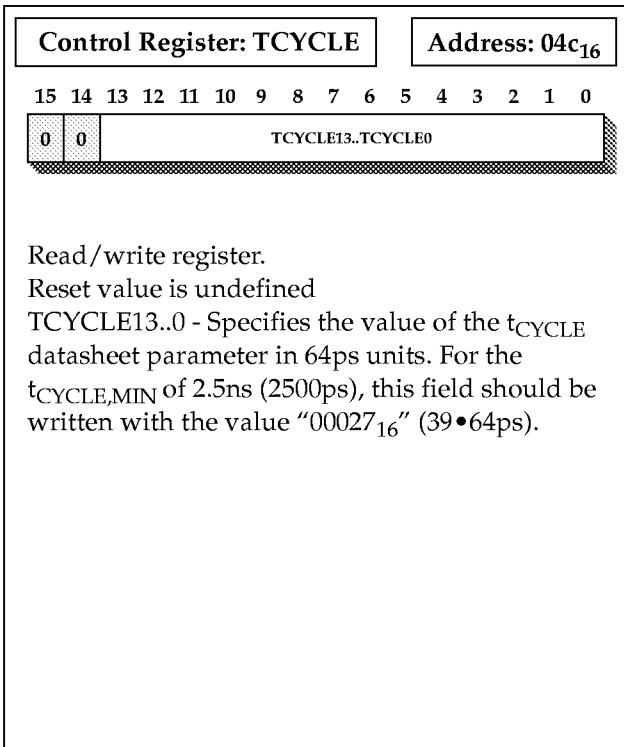
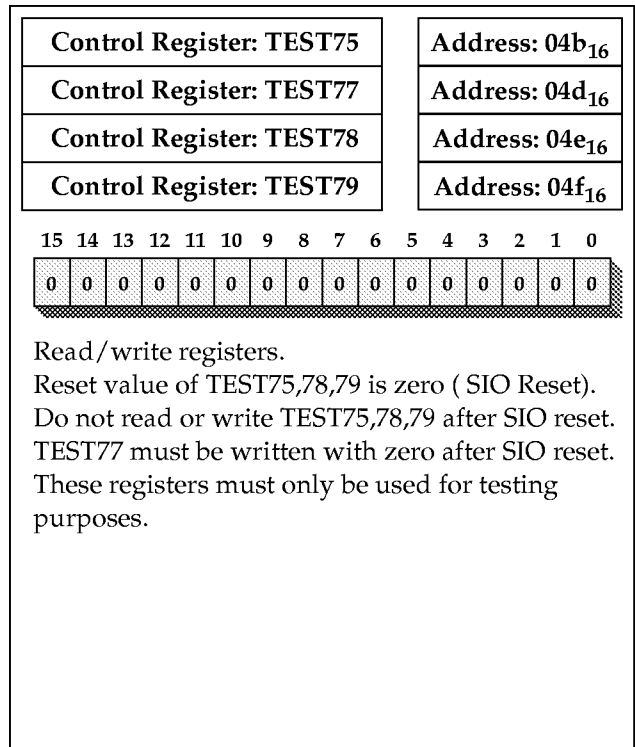

Figure 41: TRDLY Register



**Figure 42: TCYCLE Register**



**Figure 43: TEST Registers**

## Power State Management

Table 17 summarizes the power states available to a Direct RDRAM. In general, the lowest power states have the longest operational latencies. For example, the relative power levels of PDN state and STBY state have a ratio of about 1:110, and the relative access latencies to get read data have a ratio of about 250:1.

PDN state is the lowest power state available. The information in the RDRAM core is usually maintained with self-refresh; an internal timer automatically refreshes all rows of all banks. PDN has a relatively

long exit latency because the TCLK/RCLK block must resynchronize itself to the external clock signal.

NAP state is another low-power state in which either self-refresh or REFA-refresh are used to maintain the core. See “Refresh” on page 42 for a description of the two refresh mechanisms. NAP has a shorter exit latency than PDN because the TCLK/RCLK block maintains its synchronization state relative to the external clock signal at the time of NAP entry. This imposes a limit ( $t_{NLIMIT}$ ) on how long an RDRAM may remain in NAP state before briefly returning to STBY or ATTN to update this synchronization state.

Table 17: Power State Summary

Power State	Description	Blocks consuming power	Power State	Description	Blocks consuming power
PDN	Powerdown state.	Self-refresh	NAP	Nap state. Similar to PDN except lower wake-up latency.	Self-refresh or REFA-refresh TCLK/RCLK-Nap
STBY	Standby state. Ready for ROW packets.	REFA-refresh TCLK/RCLK ROW demux receiver	ATTN	Attention state. Ready for ROW and COL packets.	REFA-refresh TCLK/RCLK ROW demux receiver COL demux receiver
ATTNR	Attention read state. Ready for ROW and COL packets. Sending Q (read data) packets.	REFA-refresh TCLK/RCLK ROW demux receiver COL demux receiver DQ mux transmitter Core power	ATTNW	Attention write state. Ready for ROW and COL packets. Ready for D (write data) packets.	REFA-refresh TCLK/RCLK ROW demux receiver COL demux receiver DQ demux receiver Core power

Figure 44 summarizes the transition conditions needed for moving between the various power states. Note that NAP and PDN have been divided into two substates (NAP-A/NAP-S and PDN-A/PDN-S) to account for the fact that a NAP or PDN exit may be made to either ATTN or STBY states.

At initialization, the SETR/CLRR Reset sequence will put the RDRAM into PDN-S state. The PDN exit sequence involves an optional PDEV specification and bits on the CMD and SIO<sub>IN</sub> pins.

Once the RDRAM is in STBY, it will move to the ATTN/ATTNR/ATTNW states when it receives a non-broadcast ROWA packet or non-broadcast ROWR packet with the ATTN command. The RDRAM returns to STBY from these three states when it receives a RLX command. Alternatively, it may enter NAP or PDN state from ATTN or STBY states with a NAPR or PDNR command in an ROWR packet. The PDN or NAP exit sequence involves an optional PDEV specification and bits on the CMD and SIO<sub>0</sub> pins. The

RDRAM returns to the ATTN or STBY state it was originally in when it first entered NAP or PDN.

An RDRAM may only remain in NAP state for a time  $t_{NLIMIT}$ . It must periodically return to ATTN or STBY.

The NAPRC command causes a napdown operation if the RDRAM’s NCBIT is set. The NCBIT is not directly visible. It is undefined on reset. It is set by a NAP or NAPRC command to the RDRAM, and it is cleared by an ACT command to the RDRAM. It permits a controller to manage a set of RDRAMs in a mixture of power states.

STBY state is the normal idle state of the RDRAM. In this state all banks and sense amps have usually been left precharged and ROWA and ROWR packets on the ROW pins are being monitored. When a non-broadcast ROWA packet or non-broadcast ROWR packet (with the ATTN command) packet addressed to the RDRAM is seen, the RDRAM enters ATTN state (see the right side of Figure 45). This requires a time  $t_{SA}$  during which the RDRAM activates the specified row of the

specified bank. A time  $TFRM \cdot t_{CYCLE}$  after the ROW packet, the RDRAM will be able to frame COL packets (TFRM is a control register field - see Figure 40). Once in ATTN state, the RDRAM will automatically transition to the ATTNW and ATTNR states as it receives WR and RD commands.

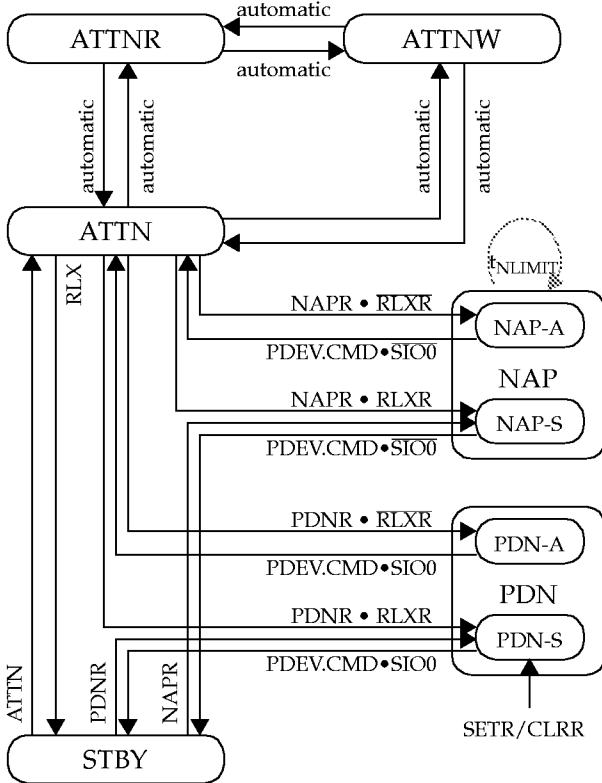

Notation:  
 SETR/CLRR - SETR/CLRR Reset sequence in SRQ packets  
 PDNR - PDNR command in ROWR packet  
 NAPR - NAPR command in ROWR packet  
 RLXR - RLX command in ROWR packet  
 RLX - RLX command in ROWR, COLC, COLX packets  
 SIO0 - SIO0 input value  
 PDEV.CMD - (PDEV=DEVID)•(CMD=01)  
 ATTN - ROWA packet (non-broadcast) or ROWR packet (non-broadcast) with ATTN command

Figure 44: Power State Transition Diagram

Once the RDRAM is in ATTN, ATTNW, or ATTNR states, it will remain there until it is explicitly returned to the STBY state with a RLX command. A RLX command may be given in an ROWR, COLC, or COLX packet (see the left side of Figure 45). It is usually given after all banks of the RDRAM have been precharged; if other banks are still activated, then the RLX command would probably not be given.

If a broadcast ROWA packet or ROWR packet (with the ATTN command) is received, the RDRAM's power state doesn't change. If a broadcast ROWR packet with RLXR command is received, the RDRAM goes to STBY.

Figure 46 shows the NAP entry sequence (left). NAP state is entered by sending a NAPR command in a ROW packet. A time  $t_{ASN}$  is required to enter NAP state (this specification is provided for power calculation purposes). The clock on CTM/CFM must remain stable for a time  $t_{CD}$  after the NAPR command.

The RDRAM may be in ATTN or STBY state when the NAPR command is issued. When NAP state is exited, the RDRAM will return to the original starting state (ATTN or STBY). If it is in ATTN state and a RLXR command is specified with NAPR, then the RDRAM will return to STBY state when NAP is exited.

Figure 46 also shows the PDN entry sequence (right). PDN state is entered by sending a PDNR command in a ROW packet. A time  $t_{ASP}$  is required to enter PDN state (this specification is provided for power calculation purposes). The clock on CTM/CFM must remain stable for a time  $t_{CD}$  after the PDNR command.

The RDRAM may be in ATTN or STBY state when the PDNR command is issued. When PDN state is exited, the RDRAM will return to the original starting state (ATTN or STBY). If it is in ATTN state and a RLXR command is specified with PDNR, then the RDRAM will return to STBY state when PDN is exited.

The RDRAM's write buffer must be retired with the appropriate COP command before NAP or PDN are entered. Also, all the RDRAM's banks must be precharged before NAP or PDN are entered. The exception to this is if NAP is entered with the NSR bit of the INIT register cleared (disabling self-refresh in NAP). The commands for relaxing, retiring, and precharging may be given to the RDRAM as late as the ROPa0, COPa0, and XOPa0 packets in Figure 46. No broadcast packets nor packets directed to the RDRAM entering Nap or PDN may overlay the quiet window. This window extends for a time  $t_{NPQ}$  after the packet with the NAPR or PDNR command.

Figure 47 shows the NAP and PDN exit sequences. These sequences are virtually identical; the minor differences will be highlighted in the following description.

Before NAP or PDN exit, the CTM/CFM clock must be stable for a time  $t_{CE}$ . Then, on a falling and rising edge of SCK, if there is a "01" on the CMD input, NAP or PDN state will be exited. Also, on the falling SCK edge the SIO0 input must be at a 0 for NAP exit and 1 for PDN exit.

If the PSX bit of the INIT register is 0, then a device PDEV5..0 is specified for NAP or PDN exit on the DQA5..0 pins. This value is driven on the rising SCK edge 0.5 or 1.5 SCK cycles after the original falling edge, depending upon the value of the DQS bit of the NAPX register. If the PSX bit of the INIT register is 1, then the RDRAM ignores the PDEV5..0 address packet and exits NAP or PDN when the wake-up sequence is presented on the CMD wire. The ROW and COL pins must be quiet at a time  $t_{S4}/t_{H4}$  around the indicated falling SCK edge (timed with the PDNX or NAPX register fields). After that, ROW and COL packets may

be directed to the RDRAM which is now in ATTN or STBY state.

Figure 48 shows the constraints for entering and exiting NAP and PDN states. On the left side, an RDRAM exits NAP state at the end of cycle  $T_3$ . This RDRAM may not re-enter NAP state for an interval of  $t_{NU0}$ . The RDRAM enters NAP state at the end of cycle  $T_{13}$ . This RDRAM may not re-exit NAP state for an interval of  $t_{NU1}$ . The equations for these two parameters depend upon a number of factors, and are shown at the bottom of the figure. NAPX is the value in the NAPX field in the NAPX register.

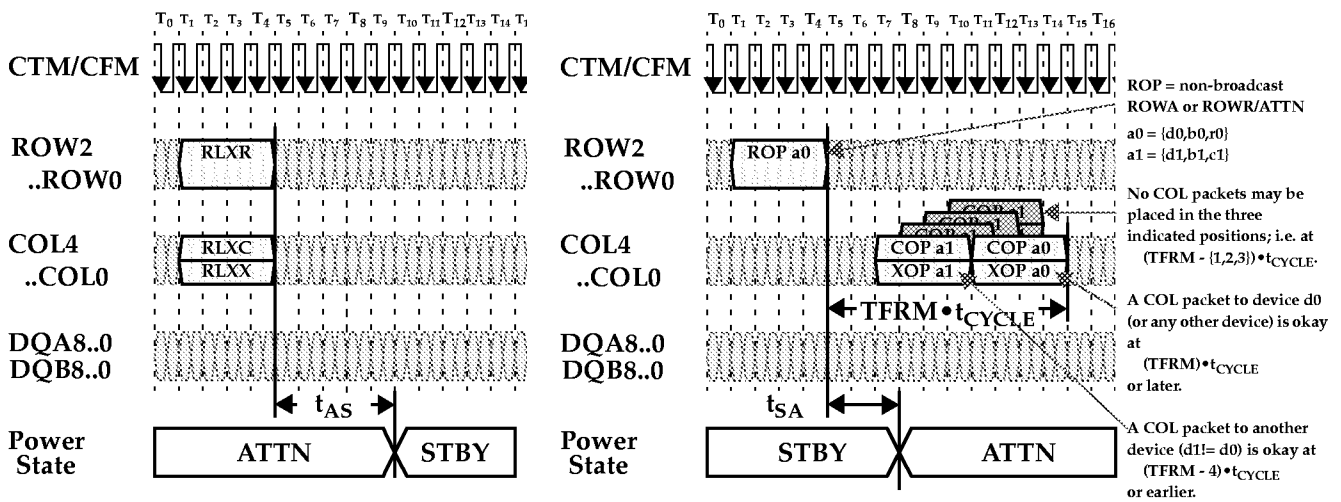
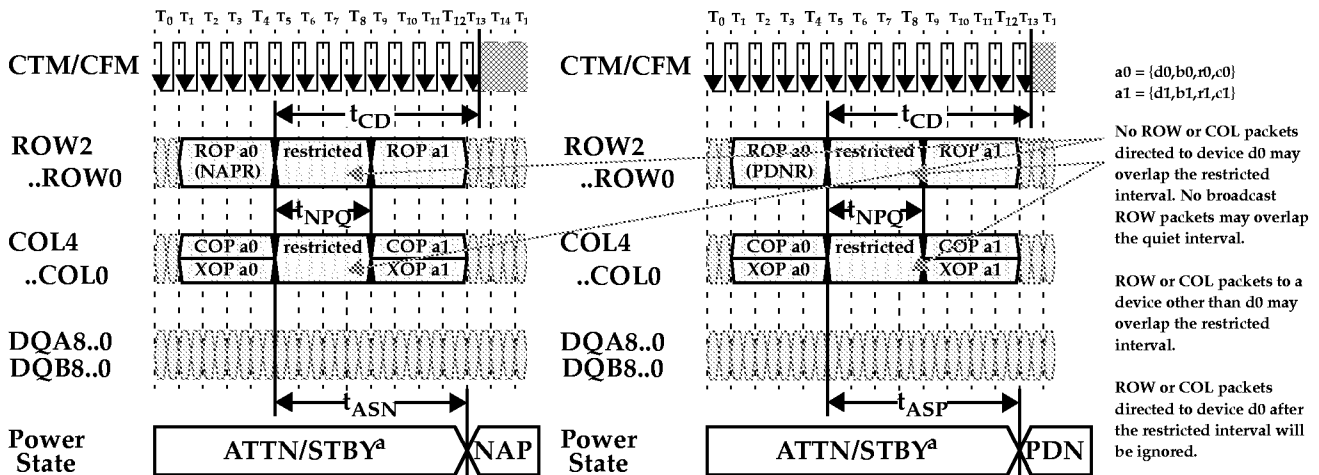

Figure 45: STBY Entry (left) and STBY Exit (right)



<sup>a</sup> The (eventual) NAP/PDN exit will be to the same ATTN/STBY state the RDRAM was in prior to NAP/PDN entry

Figure 46: NAP Entry (left) and PDN Entry (right)

On the right side of Figure 47, an RDRAM exits PDN state at the end of cycle  $T_3$ . This RDRAM may not re-

enter PDN state for an interval of  $t_{PU0}$ . The RDRAM enters PDN state at the end of cycle  $T_{13}$ . This RDRAM

may not re-exit PDN state for an interval of  $t_{PU1}$ . The equations for these two parameters depend upon a number of factors, and are shown at the bottom of the

figure. PDNX is the value in the PDNX field in the PDNX register.

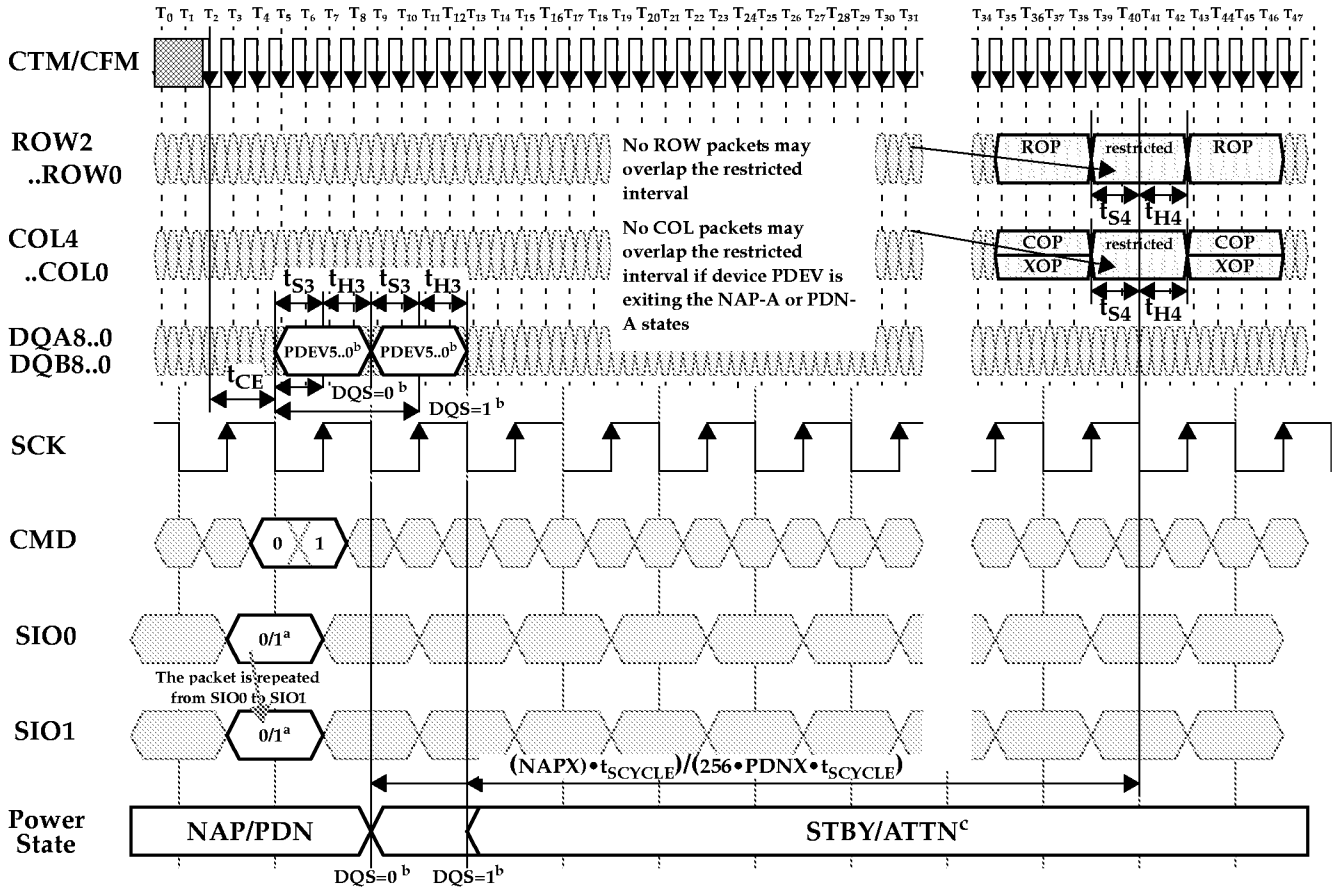

<sup>a</sup> Use 0 for NAP exit, 1 for PDN exit

<sup>c</sup> Exit to STBY or ATTN depends upon whether RLXR was asserted at NAP or PDN entry time

<sup>b</sup> Device selection timing slot is selected by DQS field of NAPX register

Figure 47: NAP and PDN Exit

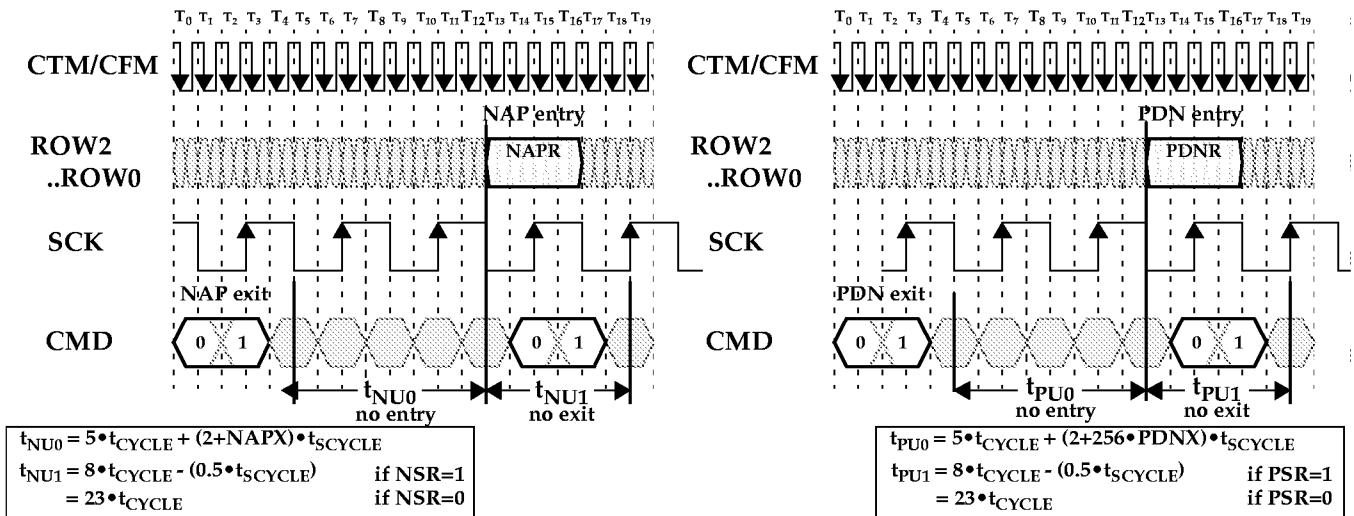

Figure 48: NAP Entry/Exit Windows (left) and PDN Entry/Exit Windows (right)

## Refresh

RDRAMs, like any other DRAM technology, use volatile storage cells which must be periodically refreshed. This is accomplished with the REFA command. Figure 49 shows an example of this.

The REFA command in the transaction is typically a broadcast command (DR4T and DR4F are both set in the ROWR packet), so that in all devices bank number Ba is activated with row number REFR, where REFR is a control register in the RDRAM. When the command is broadcast and ATTN is set, the power state of the RDRAMs (ATTN or STBY) will remain unchanged. The controller increments the bank address Ba for the next REFA command. When Ba is equal to its maximum value, the RDRAM automatically increments REFR for the next REFA command.

On average, these REFA commands are sent once every  $t_{REF}/2^{BBIT+RBIT}$  (where BBIT are the number of bank address bits and RBIT are the number of row address bits) so that each row of each bank is refreshed once every  $t_{REF}$  interval.

The REFA command is equivalent to an ACT command, in terms of the way that it interacts with other packets (see Table 10). In the example, an ACT command is sent after  $t_{RR}$  to address b0, a different (non-adjacent) bank than the REFA command.

A second ACT command can be sent after a time  $t_{RC}$  to address c0, the same bank (or an adjacent bank) as the REFA command.

Note that a broadcast REFP command is issued a time  $t_{RAS}$  after the initial REFA command in order to

precharge the refreshed bank in all RDRAMs. After a bank is given a REFA command, no other core operations (activate or precharge) should be issued to it until it receives a REFP.

It is also possible to interleave refresh transactions (not shown). In the figure, the ACT b0 command would be replaced by a REFA b0 command. The b0 address would be broadcast to all devices, and would be {Broadcast,Ba+2,REFR}. Note that the bank address should skip by two to avoid adjacent bank interference. A possible bank incrementing pattern would be: {8, 10, 12, 14, 0, 2, 4, 6, 1, 3, 5, 7, 9, 11, 13, 15}. Every time bank 15 is reached, the REFA command would automatically increment the REFR register.

A second refresh mechanism is available for use in PDN and NAP power states. This mechanism is called self-refresh mode. When the PDN power state is entered, or when NAP power state is entered with the NSR control register bit set, then self-refresh is automatically started for the RDRAM.

Self-refresh uses an internal time base reference in the RDRAM. This causes an activate and precharge to be carried out once in every  $t_{REF}/2^{BBIT+RBIT}$  interval. The REFB and REFR control registers are used to keep track of the bank and row being refreshed.

Before a controller places an RDRAM into self-refresh mode, it should perform REFA/REFP refreshes until the bank address is equal to the maximum value. This ensures that no rows are skipped. Likewise, when a controller returns an RDRAM to REFA/REFP refresh, it should start with the minimum bank address value (zero).

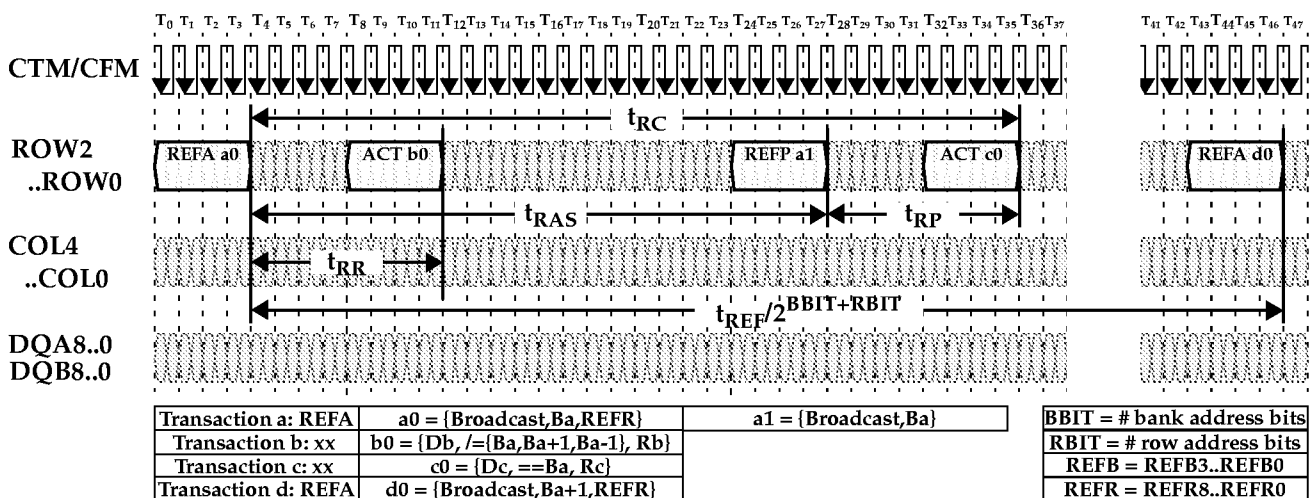

Figure 49: REFA/REFP Refresh Transaction Example

### Current and Temperature Control

Figure 50 shows an example of a transaction which performs current control calibration. It is necessary to perform this operation once to every RDRAM in every  $t_{CCTRL}$  interval in order to keep the  $I_{OL}$  output current in its proper range.

This example uses four COLX packets with a CAL command. These cause the RDRAM to drive four calibration packets  $Q(a0)$  a time  $t_{CAC}$  later. An offset of  $t_{RDTOCC}$  must be placed between the  $Q(a0)$  packet and read data  $Q(a1)$  from the same device. These calibration packets are driven on the DQA4..3 and DQB4..3 wires. The TSQ bit of the INIT register is driven on the DQA5 wire during same interval as the calibration packets. The remaining DQA and DQB wires are not used during these calibration packets. The last COLX packet also contains a SAM command (concatenated with the

CAL command). The RDRAM samples the last calibration packet and adjusts its  $I_{OL}$  current value.

Unlike REF commands, CAL and SAM commands cannot be broadcast. This is because the calibration packets from different devices would interfere. Therefore, a current control transaction must be sent every  $t_{CCTRL}/N$ , where N is the number of RDRAMs on the Channel. The device field Da of the address a0 in the CAL/SAM command should be incremented after each transaction.

Figure 51 shows an example of a temperature calibration sequence to the RDRAM. This sequence is broadcast once every  $t_{TEMP}$  interval to all the RDRAMs on the Channel. The TCEN and TCAL are ROP commands, and cause the slew rate of the output drivers to adjust for temperature drift. During the quiet interval  $t_{TCQUIET}$  the devices being calibrated can't be read, but they can be written.

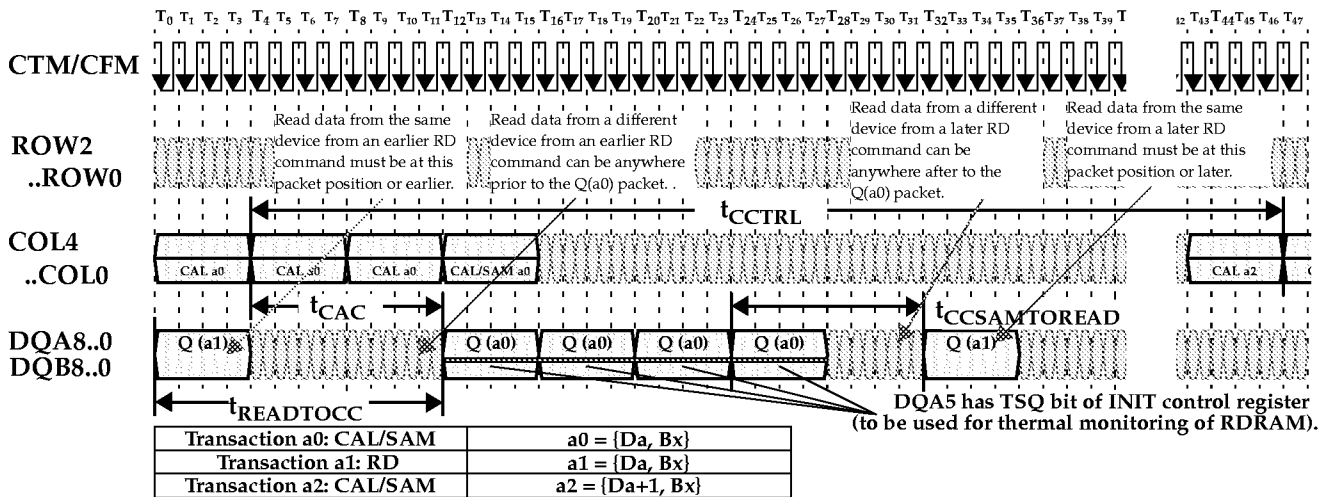

Figure 50: Current Control CAL/SAM Transaction Example

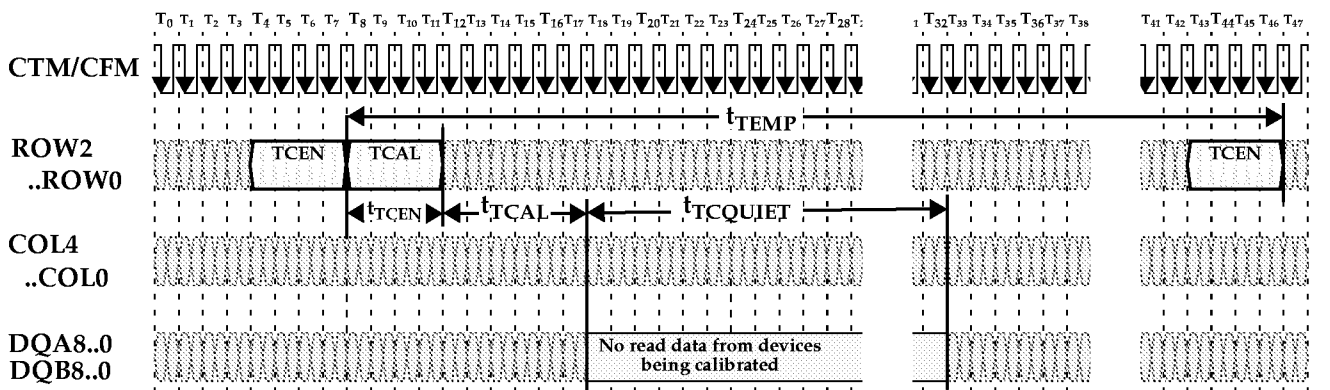

Figure 51: Temperature Calibration (TCEN-TCAL) Transactions to RDRAM

Electrical Conditions

Table 18: Electrical Conditions

Symbol	Parameter and Conditions	Min	Max	Unit
T <sub>J</sub>	Junction temperature under bias	TBD	TBD	°C
V <sub>DD</sub> , V <sub>DDA</sub>	Supply voltage	2.50 - 0.13	2.50 + 0.13	V
V <sub>DD,N</sub> , V <sub>DDA,N</sub>	Supply voltage droop (DC) during NAP interval (t <sub>NLIMIT</sub> )	-	2.0	%
V <sub>DD,N</sub> , V <sub>DDA,N</sub>	Supply voltage ripple (AC) during NAP interval (t <sub>NLIMIT</sub> )	-2.0	2.0	%
V <sub>CMOS</sub>	Supply voltage for CMOS pins (2.5V controllers)	2.50 - 0.13	2.50 + 0.25	V
	Supply voltage for CMOS pins (1.8V controllers)	1.80 - 0.1	1.80 + 0.2	V
V <sub>TERM</sub>	Termination voltage	1.80 - 0.1	1.80 + 0.1	V
V <sub>REF</sub>	Reference voltage	1.40 - 0.2	1.40 + 0.2	V
V <sub>DIL</sub>	RSL data input - low voltage	V <sub>REF</sub> - 0.5	V <sub>REF</sub> - 0.2	V
V <sub>DIH</sub>	RSL data input - high voltage	V <sub>REF</sub> + 0.2	V <sub>REF</sub> + 0.5	V
V <sub>DIS</sub>	RSL data input swing: V <sub>DIS</sub> = V <sub>DIH</sub> - V <sub>DIL</sub>	0.4	1.0	V
A <sub>DI</sub>	RSL data asymmetry: A <sub>DI</sub> = [(V <sub>DIH</sub> - V <sub>REF</sub> ) + (V <sub>DIL</sub> - V <sub>REF</sub> )]/V <sub>DIS</sub>	-10	10	%
V <sub>X</sub>	RSL clock input - crossing point of true and complement signals	1.3	1.8	V
V <sub>CIS,CTM</sub>	RSL clock input swing: V <sub>CIS</sub> = V <sub>CIH</sub> - V <sub>CIL</sub> (CTM,CTMN pins).	0.35	0.70	V
V <sub>CIS,CFM</sub>	RSL clock input swing: V <sub>CIS</sub> = V <sub>CIH</sub> - V <sub>CIL</sub> (CFM,CFMN pins).	0.10	0.70	V
V <sub>IL,CMOS</sub>	CMOS input low voltage	-0.3	V <sub>CMOS</sub> /2 - 0.25	V
V <sub>IH,CMOS</sub>	CMOS input high voltage	V <sub>CMOS</sub> /2 + 0.25	V <sub>CMOS</sub> +0.7	V

Timing Conditions

Table 19: Timing Conditions

Symbol	Parameter	Min	Max	Unit	Figure(s)
t <sub>CYCLE</sub>	CTM and CFM cycle times (-600)	3.33	3.76	ns	Figure 52
	CTM and CFM cycle times (-800)	2.50	3.34	ns	Figure 52
t <sub>CR</sub> , t <sub>CF</sub>	CTM and CFM input rise and fall times	0.2	0.5	ns	Figure 52
t <sub>CH</sub> , t <sub>CL</sub>	CTM and CFM high and low times	40%	60%	t <sub>CYCLE</sub>	Figure 52
t <sub>TR</sub>	CTM-CFM differential	0.0	1.0	t <sub>CYCLE</sub>	Figure 52
t <sub>DCW</sub>	Domain crossing window	-0.1	0.1	t <sub>CYCLE</sub>	Figure 58
t <sub>DR</sub> , t <sub>DF</sub>	DQA/DQB/ROW/COL input rise/fall times	0.2	0.65	ns	Figure 53
t <sub>S</sub> , t <sub>H</sub>	DQA/DQB/ROW/COL-to-CFM setup/hold t <sub>CYCLE</sub> =2.5ns @ t <sub>CYCLE</sub> =3.3ns	0.200 0.275	-	ns	Figure 53
t <sub>DR1</sub> , t <sub>DF1</sub>	SIO0, SIO1 input rise and fall times	-	5.0	ns	Figure 55
t <sub>DR2</sub> , t <sub>DF2</sub>	CMD, SCK input rise and fall times	-	2.0	ns	Figure 55

**Table 19: Timing Conditions**

Symbol	Parameter	Min	Max	Unit	Figure(s)
t <sub>CYCLE1</sub>	SCK cycle time - Serial control register transactions	1000	-	ns	Figure 55
	SCK cycle time - Power transitions	10	-	ns	Figure 55
t <sub>CH1</sub> , t <sub>CL1</sub>	SCK high and low times	4.25	-	ns	Figure 55
t <sub>S1</sub>	CMD setup time to SCK rising or falling edge	1	-	ns	Figure 55
t <sub>H1</sub>	CMD hold time to SCK rising or falling edge	1	-	ns	Figure 55
t <sub>S2</sub>	SIO0 setup time to SCK falling edge	40	-	ns	Figure 55
t <sub>H2</sub>	SIO0 hold time to SCK falling edge	40	-	ns	Figure 55
t <sub>S3</sub>	PDEV setup time on DQA5..0 to SCK rising edge.	0	-	ns	Figure 47, Figure 56
t <sub>H3</sub>	PDEV hold time on DQA5..0 to SCK rising edge.	5.5	-	ns	Figure 47, Figure 56
t <sub>S4</sub>	ROW2..0, COL4..0 setup time for quiet window	-1	-	t <sub>CYCLE</sub>	Figure 47
t <sub>H4</sub>	ROW2..0, COL4..0 hold time for quiet window	5	-	t <sub>CYCLE</sub>	Figure 47
V <sub>IL,CMOS</sub>	CMOS input low voltage - over/undershoot voltage duration is less than or equal to 5ns	-0.7	V <sub>CMOS</sub> /2 - 0.6	V	
V <sub>IH,CMOS</sub>	CMOS input high voltage - over/undershoot voltage duration is less than or equal to 5ns	V <sub>CMOS</sub> /2 + 0.6	V <sub>CMOS</sub> + 0.7	V	
t <sub>NPQ</sub>	Quiet on ROW/COL bits during NAP/PDN entry	4	-	t <sub>CYCLE</sub>	Figure 46
t <sub>READTOCC</sub>	Offset between read data and CC packets (same device)	12	-	t <sub>CYCLE</sub>	Figure 50
t <sub>CCSAMTOREAD</sub>	Offset between CC packet and read data (same device)	8	-	t <sub>CYCLE</sub>	Figure 50
t <sub>CE</sub>	CTM/CFM stable before NAP/PDN exit	2	-	t <sub>CYCLE</sub>	Figure 47
t <sub>CD</sub>	CTM/CFM stable after NAP/PDN entry	25	-	t <sub>CYCLE</sub>	Figure 46
t <sub>FRM</sub>	ROW packet to COL packet ATTN framing delay	7	-	t <sub>CYCLE</sub>	Figure 45
t <sub>NLIMIT</sub>	Maximum time in NAP mode		10.0	μs	Figure 44
t <sub>REF</sub>	Refresh interval		32	ms	Figure 49
t <sub>CCTRL</sub>	Current control interval	0.0001	100	ms	Figure 50
t <sub>TEMP</sub>	Temperature control interval		100	ms	Figure 51
t <sub>TCEN</sub>	TCE command to TCAL command	4	250	t <sub>CYCLE</sub>	Figure 51
t <sub>TCAL</sub>	TCAL command to quiet window	6	6	t <sub>CYCLE</sub>	Figure 51
t <sub>TCQUIET</sub>	Quiet window (no read data)	140	-	t <sub>CYCLE</sub>	Figure 51
t <sub>RAS</sub>	RAS interval (time a row may stay activated)		64	μs	Figure 15 Figure 16
t <sub>PAUSE</sub>	RDRAM delay (no RSL operations allowed)		200.0	μs	page 28

## Electrical Characteristics

Table 20: Electrical Characteristics

Symbol	Parameter and Conditions	Min	Max	Unit
$\Theta_{JC}$	Junction-to-Case thermal resistance		TBD	°C/Watt
$I_{REF}$	$V_{REF}$ current @ $V_{REF,MAX}$	-10	10	μA
$I_{OH}$	RSL output high current @ ( $0 \leq V_{OUT} \leq V_{DD}$ )	-10	10	μA
$I_{ALL}$	RSL $I_{OL}$ current @ $V_{OL} = 0.9V, V_{DD,MIN}, T_{J,MAX}$ <sup>a</sup>	30.0	90.0	mA
$\Delta I_{OL}$	RSL $I_{OL}$ current resolution step	-	1.5	mA
$r_{OUT}$	Dynamic output impedance	150	-	Ω
$I_{I,CMOS}$	CMOS input leakage current @ ( $0 \leq V_{I,CMOS} \leq V_{CMOS}$ )	-10.0	10.0	μA
$V_{OL,CMOS}$	CMOS output voltage @ $I_{OL,CMOS} = 1.0mA$	-	0.3	V
$V_{OH,CMOS}$	CMOS output high voltage @ $I_{OH,CMOS} = -0.25mA$	$V_{CMOS}-0.3$	-	V

a. This measurement is made in manual current control mode; i.e. with all output device legs sinking current.

## Timing Characteristics

Table 21: Timing Characteristics

Symbol	Parameter	Min	Max	Unit	Figure(s)
$t_Q$	CTM-to-DQA/DQB output time @ $t_{CYCLE}=2.5ns$ @ $t_{CYCLE}=3.3ns$	-0.30 -0.40	+0.30 +0.40	ns	Figure 54
$t_{QR}, t_{QF}$	DQA/DQB output rise and fall times	0.2	0.45	ns	Figure 54
$t_{Q1}$	SCK-to-SIO0 delay @ $C_{LOAD,MAX} = 20pF$ (SD read packet).	-	10	ns	Figure 57
$t_{QR1}, t_{QF1}$	SIO <sub>OUT</sub> rise/fall @ $C_{LOAD,MAX} = 20pF$	-	5	ns	Figure 57
$t_{PROPI}$	SIO0-to-SIO1 or SIO1-to-SIO0 delay @ $C_{LOAD,MAX} = 20pF$	-	10	ns	Figure 57
$t_{NAPXA}$	NAP exit delay - phase A	-	50	ns	Figure 47
$t_{NAPXB}$	NAP exit delay - phase B	-	40	ns	Figure 47
$t_{PDNXA}$	PDN exit delay - phase A	-	4	μs	Figure 47
$t_{PDNXB}$	PDN exit delay - phase B	-	8	μs	Figure 47
$t_{AS}$	ATTN-to-STBY power state delay	1	4	$t_{CYCLE}$	Figure 45
$t_{SA}$	STBY-to-ATTN power state delay	-	3	$t_{CYCLE}$	Figure 45
$t_{ASN}$	ATTN/STBY-to-NAP power state delay	-	8	$t_{CYCLE}$	Figure 46
$t_{ASP}$	ATTN/STBY-to-PDN power state delay	-	8	$t_{CYCLE}$	Figure 46

**RSL - Clocking**

Figure 52 is a timing diagram which shows the detailed requirements for the RSL clock signals on the Channel.

The CTM and CTMN are differential clock inputs used for transmitting information on the DQA and DQB,

outputs. Most timing is measured relative to the points where they cross. The  $t_{CYCLE}$  parameter is measured from the falling CTM edge to the falling CTM edge. The  $t_{CL}$  and  $t_{CH}$  parameters are measured from falling to rising and rising to falling edges of CTM. The  $t_{CR}$  and  $t_{CF}$  rise- and fall-time parameters are measured at the 20% and 80% points.

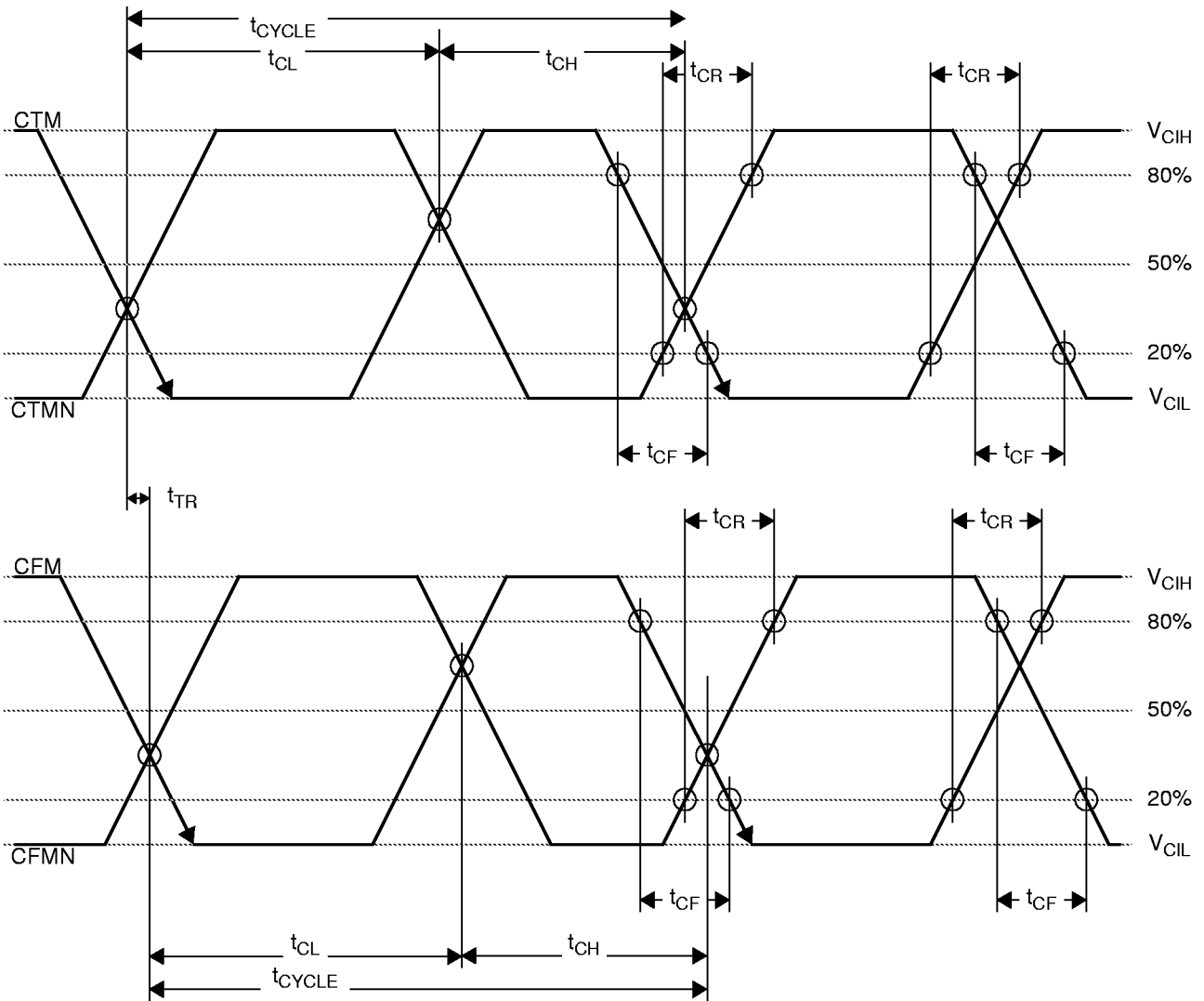

**Figure 52: RSL Timing - Clock Signals**

The CFM and CFMN are differential clock outputs used for receiving information on the DQA, DQB, ROW and COL outputs. Most timing is measured relative to the points where they cross. The  $t_{CYCLE}$  parameter is measured from the falling CFM edge to the falling CFM edge. The  $t_{CL}$  and  $t_{CH}$  parameters are measured from falling to rising and rising to falling

edges of CFM. The  $t_{CR}$  and  $t_{CF}$  rise- and fall-time parameters are measured at the 20% and 80% points.

The  $t_{TR}$  parameter specifies the phase difference that may be tolerated with respect to the CTM and CFM differential clock inputs (the CTM pair is always earlier).

### RSL - Receive Timing

Figure 53 is a timing diagram which shows the detailed requirements for the RSL input signals on the Channel.

The DQA, DQB, ROW, and COL signals are inputs which receive information transmitted by a Direct RAC on the Channel. Each signal is sampled twice per  $t_{\text{CYCLE}}$  interval. The set/hold window of the sample

points is  $t_{\text{S}}/t_{\text{H}}$ . The sample points are centered at the 0% and 50% points of a cycle, measured relative to the crossing points of the falling CFM clock edge. The set and hold parameters are measured at the  $V_{\text{REF}}$  voltage point of the input transition.

The  $t_{\text{DR}}$  and  $t_{\text{DF}}$  rise- and fall-time parameters are measured at the 20% and 80% points of the input transition.

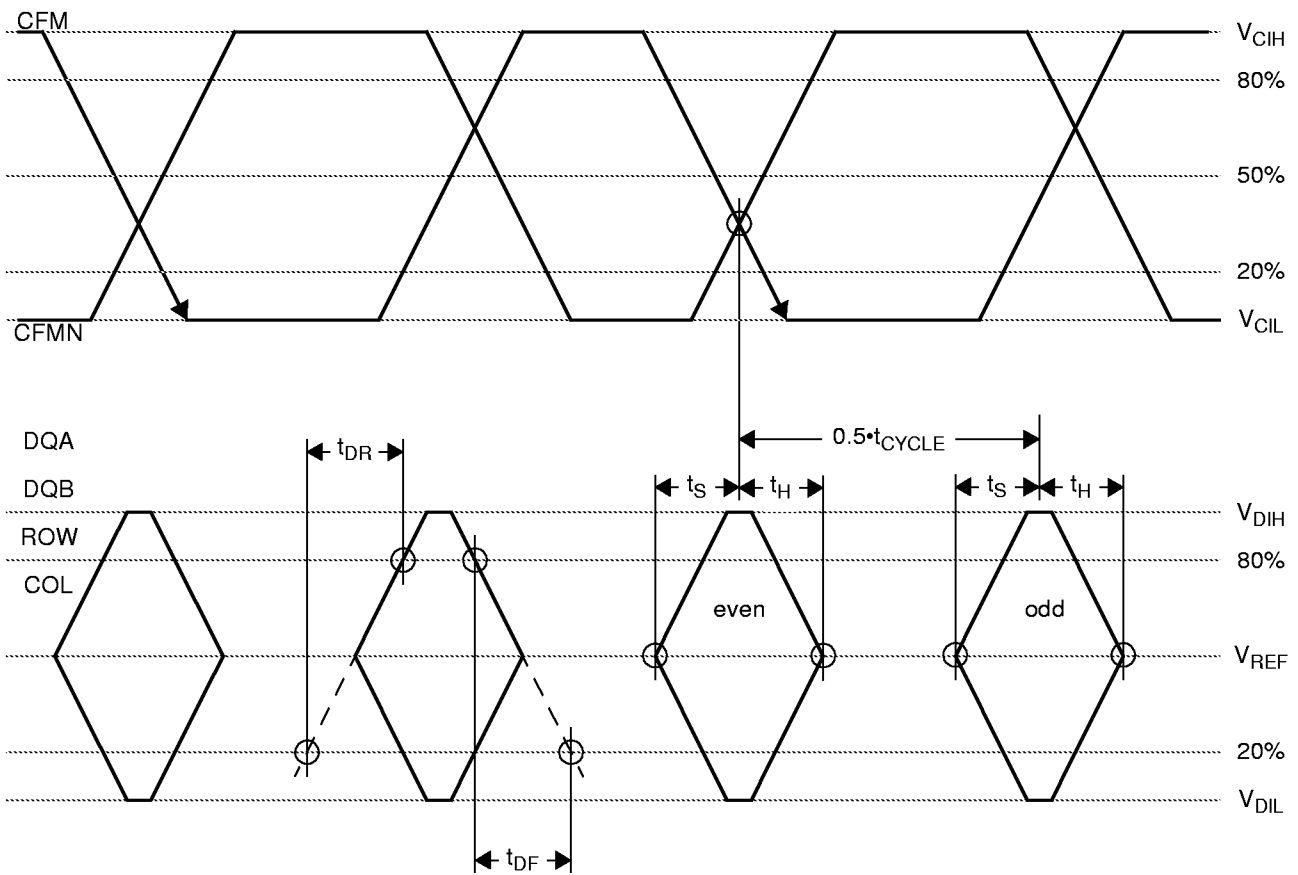

Figure 53: RSL Timing - Data Signals for Receive

### RSL - Transmit Timing

Figure 54 is a timing diagram which shows the detailed requirements for the RSL output signals on the Channel.

The DQA and DQB signals are outputs to transmit information that is received by a Direct RAC on the Channel. Each signal is driven twice per  $t_{CYCLE}$  interval. The beginning and end of the even transmit window is at the 75% point of the previous cycle and at the 25% point of the current cycle. The beginning and

end of the odd transmit window is at the 25% point and at the 75% point of the current cycle. These transmit points are measured relative to the crossing points of the falling CTM clock edge. The size of the actual transmit window is less than the ideal  $t_{CYCLE}/2$ , as indicated by the non-zero values of  $t_{Q,MIN}$  and  $t_{Q,MAX}$ . The  $t_Q$  parameters are measured at the  $V_{REF}$  voltage point of the output transition.

The  $t_{QR}$  and  $t_{QF}$  rise- and fall-time parameters are measured at the 20% and 80% points of the output transition.

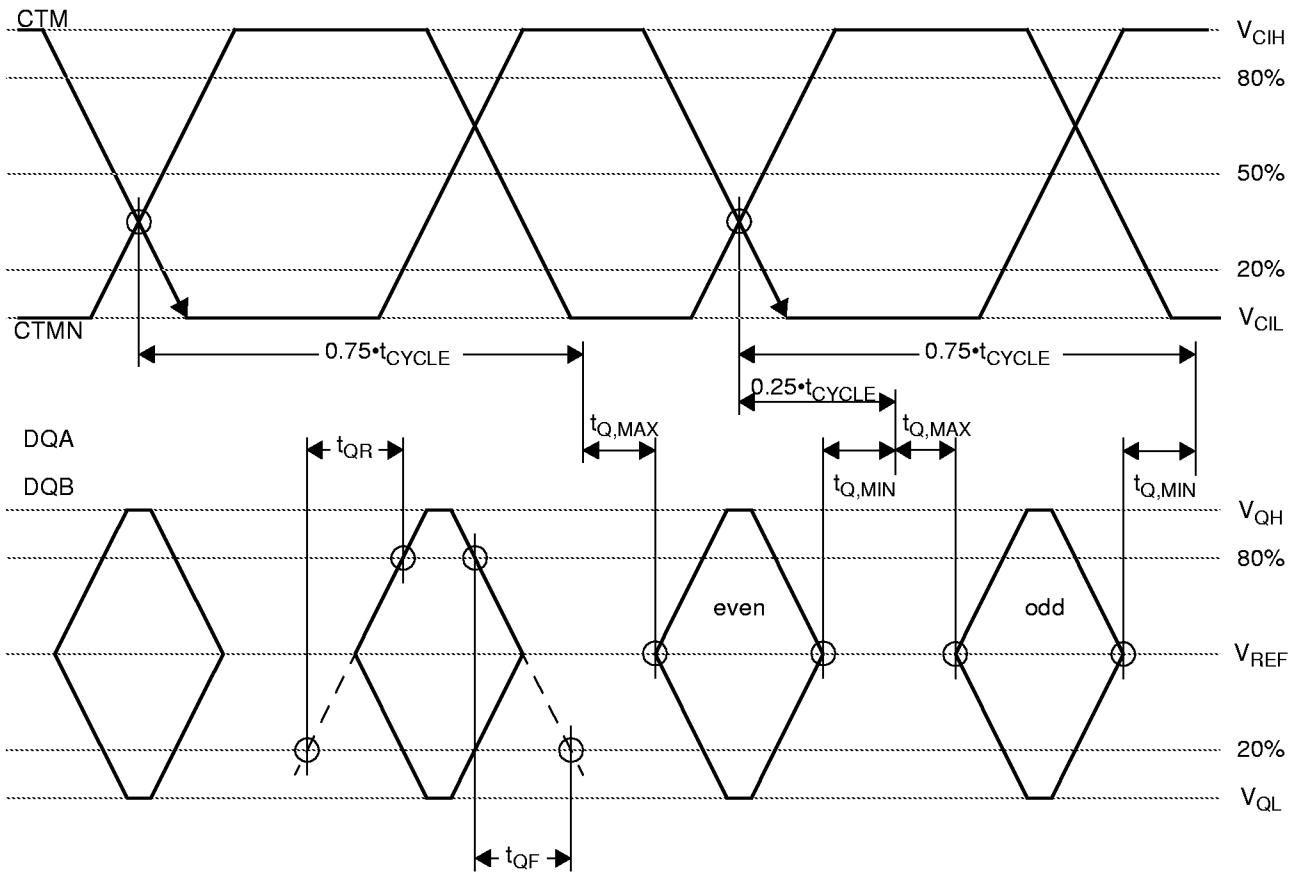

Figure 54: RSL Timing - Data Signals for Transmit

### CMOS - Receive Timing

Figure 55 is a timing diagram which shows the detailed requirements for the CMOS input signals .

The CMD and SIO0 signals are inputs which receive information transmitted by a controller (or by another RDRAM's SIO1 output). SCK is the CMOS clock signal driven by the controller. All signals are high true.

The cycle time, high phase time, and low phase time of the SCK clock are  $t_{CYCLE1}$ ,  $t_{CH1}$  and  $t_{CL1}$ , all measured at the 50% level. The rise and fall times of SCK, CMD,

and SIO0 are  $t_{DR1}$  and  $t_{DF1}$ , measured at the 20% and 80% levels.

The CMD signal is sampled twice per  $t_{CYCLE1}$  interval, on the rising edge (odd data) and the falling edge (even data). The set/hold window of the sample points is  $t_{S1}/t_{H1}$ . The SCK and CMD timing points are measured at the 50% level.

The SIO0 signal is sampled once per  $t_{CYCLE1}$  interval on the falling edge. The set/hold window of the sample points is  $t_{S2}/t_{H2}$ . The SCK and SIO0 timing points are measured at the 50% level.

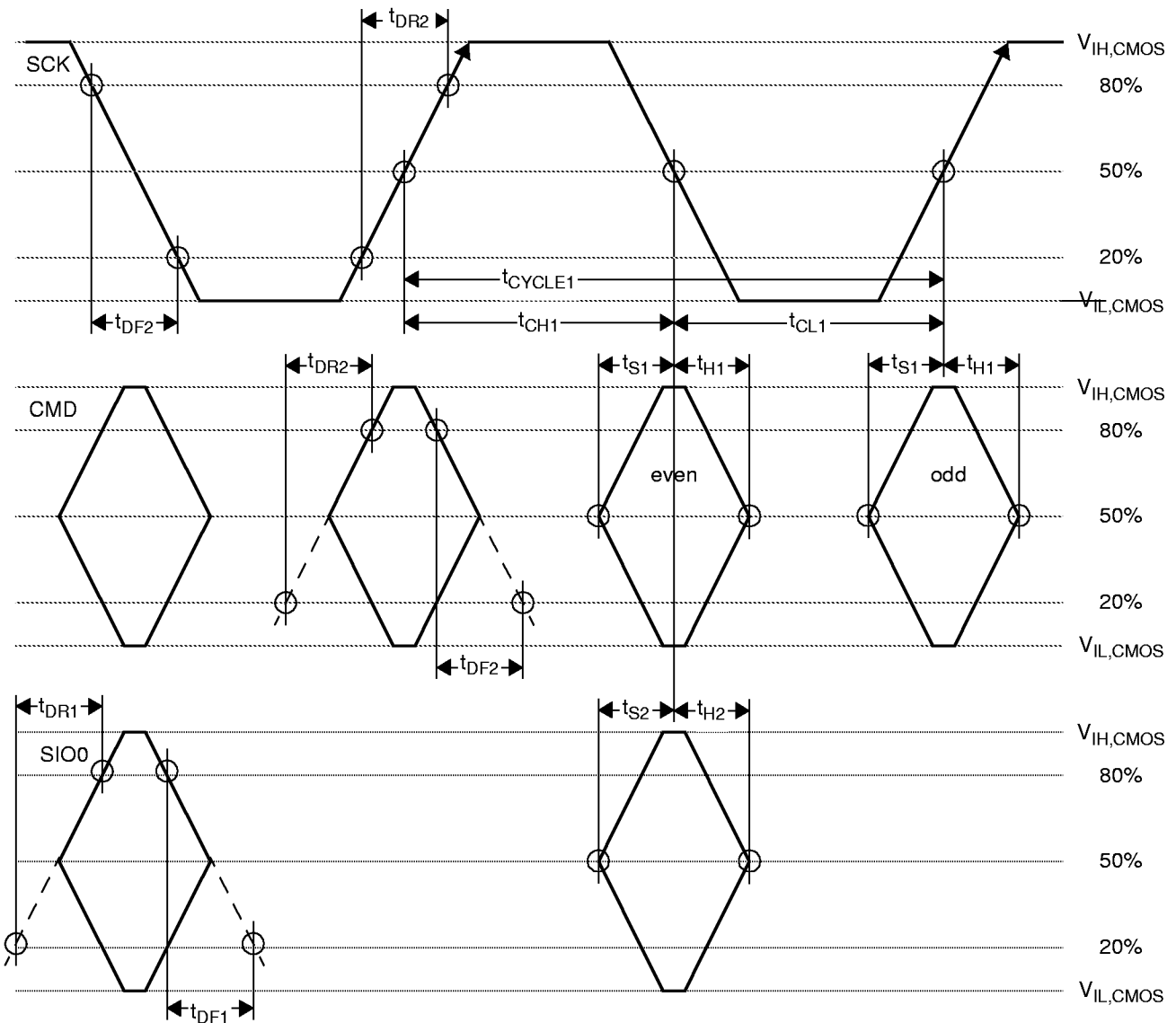

Figure 55: CMOS Timing - Data Signals for Receive

The SCK clock is also used for sampling data on RSL inputs in one situation. Figure 47 shows the PDN and NAP exit sequences. If the PSX field of the INIT register is zero (see Figure 27), then the PDN and NAP exit sequences are broadcast; i.e. all RDRAMs that are in PDN or NAP will perform the exit sequence. If the PSX field of the INIT register is one, then the PDN and

NAP exit sequences are directed; i.e. only one RDRAM that is in PDN or NAP will perform the exit sequence.

The address of that RDRAM is specified on the DQA[5:0] bus in the set hold window  $t_{S3}/t_{H3}$  around the rising edge of SCK. This is shown in Figure 56. The SCK timing point is measured at the 50% level, and the DQA[5:0] bus signals are measured at the  $V_{REF}$  level.

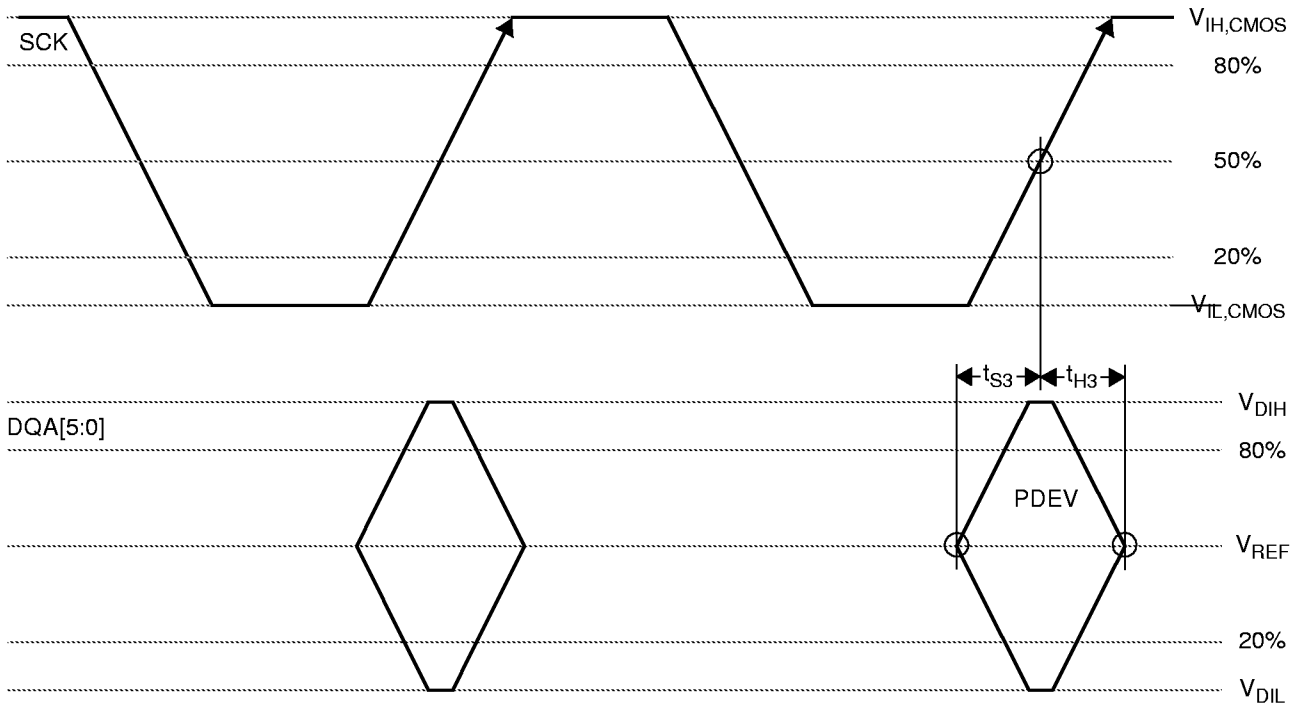

Figure 56: CMOS Timing - Device Address for NAP or PDN Exit

CMOS - Transmit Timing

Figure 57 is a timing diagram which shows the detailed requirements for the CMOS output signals. The SIO0 signal is driven once per  $t_{CYCLE1}$  interval on

the falling edge. The clock-to-output window is  $t_{Q1,MIN}/t_{Q1,MAX}$ . The SCK and SIO0 timing points are measured at the 50% level. The rise and fall times of SIO0 are  $t_{QR1}$  and  $t_{QF1}$ , measured at the 20% and 80% levels.

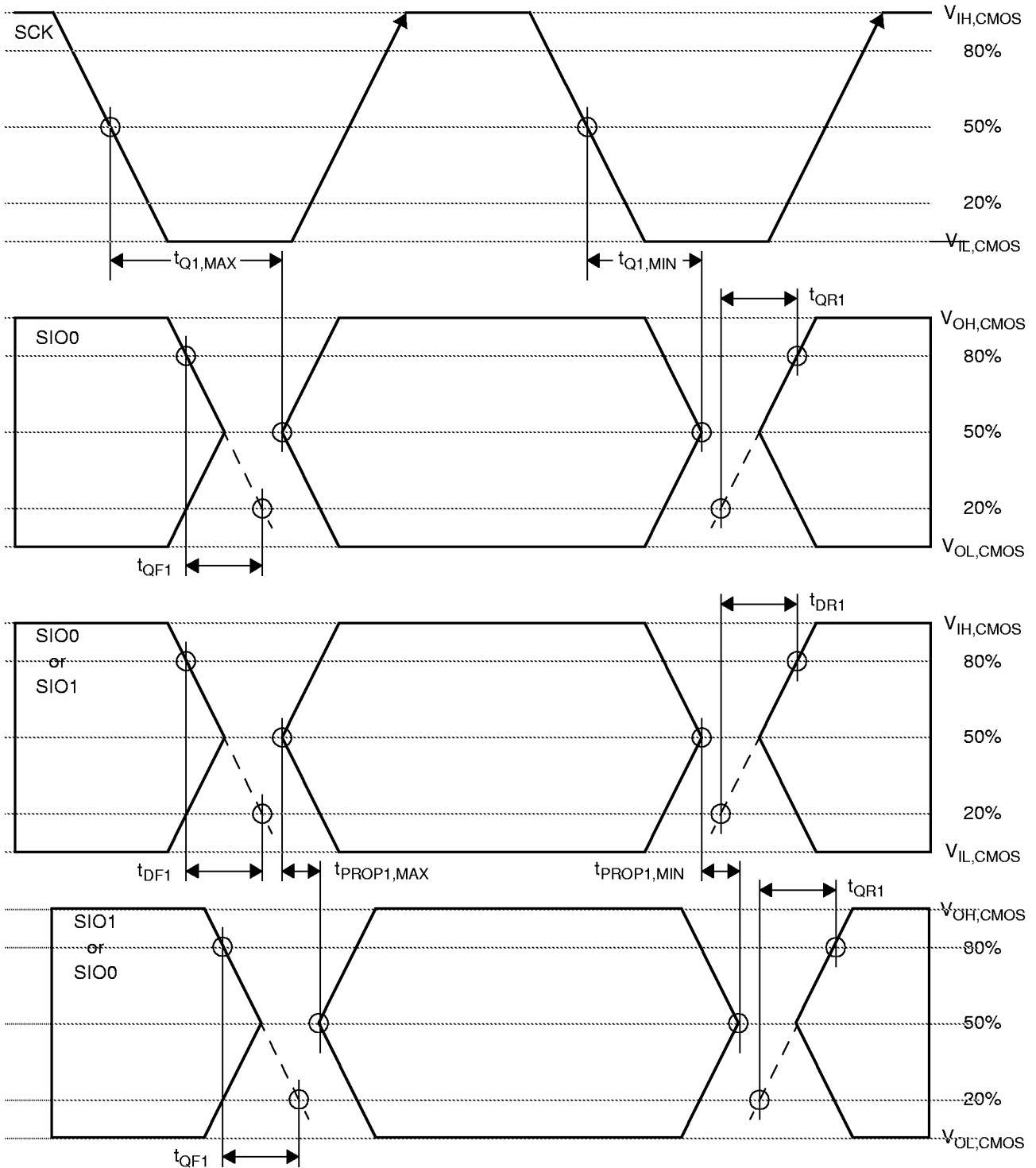

Figure 57: CMOS Timing - Data Signals for Transmit

Figure 57 also shows the combinational path connecting SIO0 to SIO1 and the path connecting SIO1 to SIO0 (read data only). The  $t_{PROP1}$  parameter specifies this propagation delay. The rise and fall times of SIO0 and SIO1 inputs must be  $t_{DR1}$  and  $t_{DF1}$ , measured at the 20% and 80% levels. The rise and fall times of SIO0 and SIO1 outputs are  $t_{QR1}$  and  $t_{QF1}$ , measured at the 20% and 80% levels.

### RSL - Domain Crossing Window

When read data is returned by the RDRAM, information must cross from the receive clock domain (CFM) to the transmit clock domain (CTM). The  $t_{TR}$  parameter permits the CFM to CTM phase to vary through an entire cycle; i.e. there is no restriction on the alignment of these two clocks. A second parameter  $t_{DCW}$  is needed in order to describe how the delay between a

RD command packet and read data packet varies as a function of the  $t_{TR}$  value.

Figure 58 shows this timing for five distinct values of  $t_{TR}$ . Case A ( $t_{TR}=0$ ) is what has been used throughout this document. The delay between the RD command and read data is  $t_{CAC}$ . As  $t_{TR}$  varies from zero to  $t_{DCW,MAX}$ , the command to data delay is  $(t_{CAC}-t_{TR})$ . When the  $t_{TR}$  value is in the range 0 to  $t_{DCW,MAX}$ , the command to data delay can also be  $(t_{CAC}-t_{TR}-t_{CYCLE})$ . This is shown as cases A' and B' (the gray packets). Similarly, when the  $t_{TR}$  value is in the range  $(t_{CYCLE}+t_{DCW,MIN})$  to  $t_{CYCLE}$ , the command to data delay can also be  $(t_{CAC}-t_{TR}+t_{CYCLE})$ . This is shown as cases D' and E' (the gray packets). The RDRAM will work reliably with either the white or gray packet timing. The delay value is selected at initialization, and remains fixed thereafter.

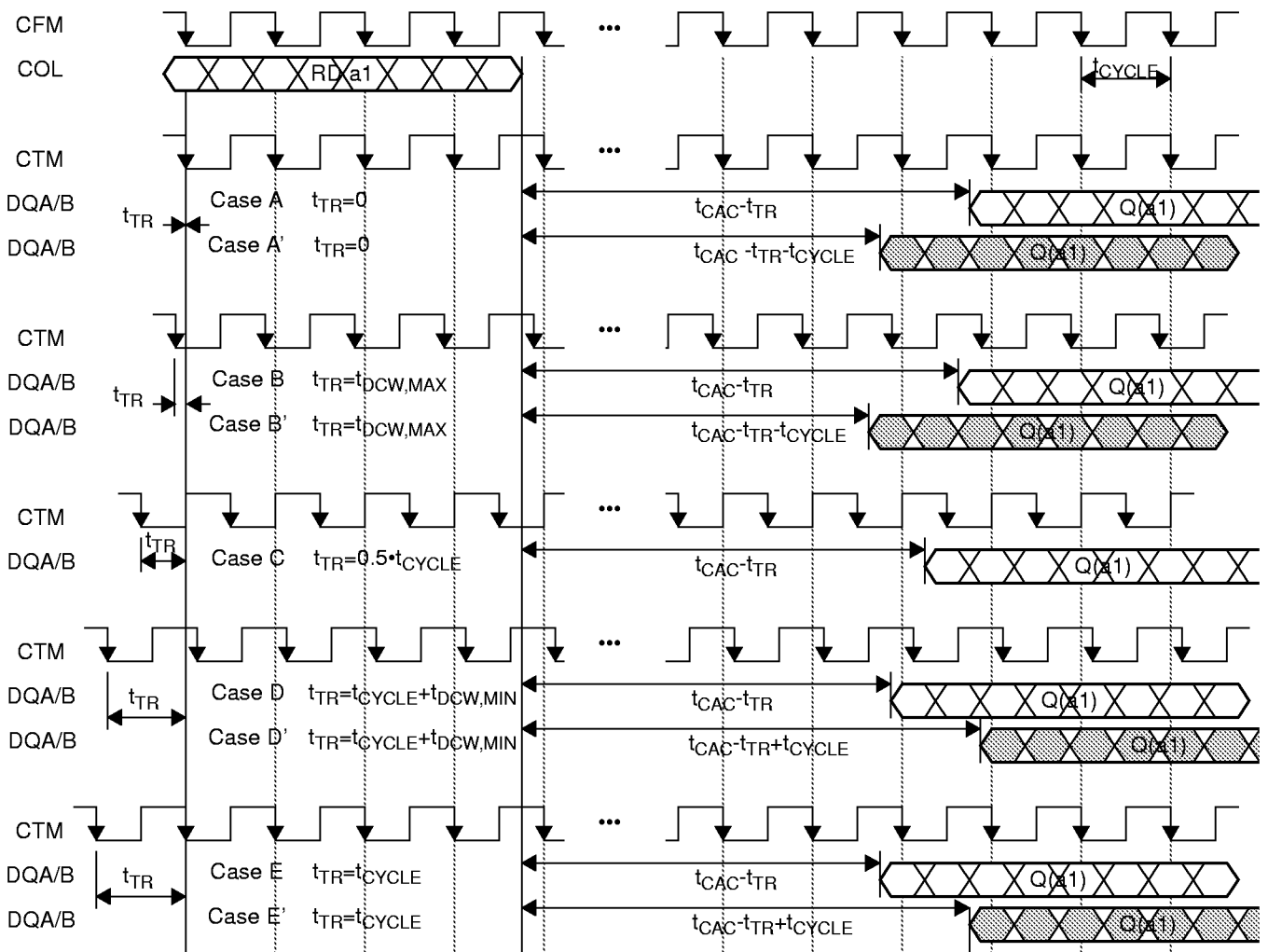

Figure 58: RSL Transmit - Crossing Read Domains

## Timing Parameters

Table 22: Timing Parameter Summary

Parameter	Description	Min -40 -800	Min -45 -800	Min -50 -800	Min -45 -600	Min -53 -600	Max	Units	Figure(s)
$t_{RC}$	Row Cycle time of RDRAM banks -the interval between ROWA packets with ACT commands to the same bank.	28	28	34	22	28	-	$t_{CYCLE}$	Figure 15 Figure 16
$t_{RAS}$	RAS-asserted time of RDRAM bank - the interval between ROWA packet with ACT command and next ROWR packet with PRER <sup>a</sup> command to the same bank.	20	20	24	16	20	- <sup>b</sup>	$t_{CYCLE}$	Figure 15 Figure 16
$t_{RP}$	Row Precharge time of RDRAM banks - the interval between ROWR packet with PRER <sup>a</sup> command and next ROWA packet with ACT command to the same bank.	8	8	10	6	8	-	$t_{CYCLE}$	Figure 15 Figure 16
$t_{PP}$	Precharge-to-precharge time of RDRAM device - the interval between successive ROWR packets with PRER <sup>a</sup> commands to any banks of the same device.	8	8	8	8	8	-	$t_{CYCLE}$	Figure 12
$t_{RR}$	RAS-to-RAS time of RDRAM device - the interval between successive ROWA packets with ACT commands to any banks of the same device.	8	8	8	8	8	-	$t_{CYCLE}$	Figure 13
$t_{RCD}$	RAS-to-CAS Delay - the interval from ROWA packet with ACT command to COLC packet with RD or WR command). Note - the RAS-to-CAS delay seen by the RDRAM core ( $t_{RCD-C}$ ) is equal to $t_{RCD} = 1 + t_{RCD}$ because of differences in the row and column paths through the RDRAM interface.	7	9	11	5	7	-	$t_{CYCLE}$	Figure 15 Figure 16
$t_{CAC}$	CAS Access delay - the interval from RD command to Q read data. The equation for $t_{CAC}$ is given in the TPARM register in Figure 39.	8	8	8	7	8	12	$t_{CYCLE}$	Figure 4 Figure 39
$t_{CWD}$	CAS Write Delay (interval from WR command to D write data.	6	6	6	6	6	6	$t_{CYCLE}$	Figure 4
$t_{CC}$	CAS-to-CAS time of RDRAM bank - the interval between successive COLC commands).	4	4	4	4	4	-	$t_{CYCLE}$	Figure 15 Figure 16
$t_{PACKET}$	Length of ROWA, ROWR, COLC, COLM or COLX packet.	4	4	4	4	4	4	$t_{CYCLE}$	Figure 3
$t_{RTR}$	Interval from COLC packet with WR command to COLC packet which causes retire, and to COLM packet with bytemask.	8	8	8	8	8	-	$t_{CYCLE}$	Figure 17
$t_{OFFP}$	The interval (offset) from COLC packet with RDA command, or from COLC packet with retire command (after WRA automatic precharge), or from COLX packet with PREX command to the equivalent ROWR packet with PRER. The equation for $t_{OFFP}$ is given in the TPARM register in Figure 39.	4	4	4	4	4	4	$t_{CYCLE}$	Figure 14 Figure 39
$t_{RDP}$	Interval from last COLC packet with RD command to ROWR packet with PRER.	4	4	4	4	4	-	$t_{CYCLE}$	Figure 15
$t_{RTP}$	Interval from last COLC packet with automatic retire command to ROWR packet with PRER.	4	4	4	4	4	-	$t_{CYCLE}$	Figure 16

a. Or equivalent PREC or PREX command. See Figure 14.

b. See  $t_{RAS,MAX}$  value in "Timing Conditions" on page 44.

## Absolute Maximum Ratings

Table 23: Absolute Maximum Ratings

Symbol	Parameter	Min	Max	Unit
$V_{I,ABS}$	Voltage applied to any RSL or CMOS pin with respect to Gnd	-0.3	$V_{DD}+0.3$	V
$V_{DD,ABS}, V_{DDA,ABS}$	Voltage on VDD and VDDA with respect to Gnd	-0.5	$V_{DD}+1.0$	V
$T_{STORE}$	Storage temperature	-50	100	°C

## $I_{DD}$ - Supply Current Profile

Table 24: Supply Current Profile

$I_{DD}$ value	RDRAM blocks consuming power @ $t_{CYCLE}=2.5ns$	Min	Max	Unit
$I_{DD,PDN}$	Self-refresh only for INIT.LSR=0	TBD	1500	$\mu A$
$I_{DD,PDN,L}$	Self-refresh only for INIT.LSR= 1	TBD	300	$\mu A$
$I_{DD,NAP}$	Refresh, T/RCLK-Nap	TBD	TBD	mA
$I_{DD,STBY}$	Refresh, T/RCLK, ROW-demux	TBD	TBD	mA
$I_{DD,ATTN}$	Refresh, T/RCLK, ROW-demux, COL-demux	TBD	TBD	mA
$I_{DD,ATTN-W}$	Refresh,T/RCLK, ROW-demux,COL-demux,DQ-demux,1•WR-SenseAmp,4•ACT-Bank	TBD	TBD	mA
$I_{DD,ATTN-R}$	Refresh,T/RCLK, ROW-demux,COL-demux,DQ-mux,1•RD-SenseAmp,4•ACT-Bank <sup>a</sup>	TBD	TBD	mA

$I_{DD}$ value	RDRAM blocks consuming power @ $t_{CYCLE}=3.3ns$	Min	Max	Unit
$I_{DD,PDN}$	Self-refresh only for INIT.LSR=0	TBD	1500	$\mu A$
$I_{DD,PDN,L}$	Self-refresh only for INIT.LSR= 1	TBD	300	$\mu A$
$I_{DD,NAP}$	Refresh, T/RCLK-Nap	TBD	TBD	mA
$I_{DD,STBY}$	Refresh, T/RCLK, ROW-demux	TBD	TBD	mA
$I_{DD,ATTN}$	Refresh, T/RCLK, ROW-demux, COL-demux	TBD	TBD	mA
$I_{DD,ATTN-W}$	Refresh,T/RCLK, ROW-demux,COL-demux,DQ-demux,1•WR-SenseAmp,4•ACT-Bank	TBD	TBD	mA
$I_{DD,ATTN-R}$	Refresh,T/RCLK, ROW-demux,COL-demux,DQ-mux,1•RD-SenseAmp,4•ACT-Bank <sup>a</sup>	TBD	TBD	mA

a. This does not include the  $I_{OL}$  sink current. The RDRAM dissipates  $I_{OL} \cdot V_{OL}$  in each output driver when a logic one is driven.

### Capacitance and Inductance

and CMOS pins. The circuit models the load that the device presents to the Channel.

Figure 59 shows the equivalent load circuit of the RSL

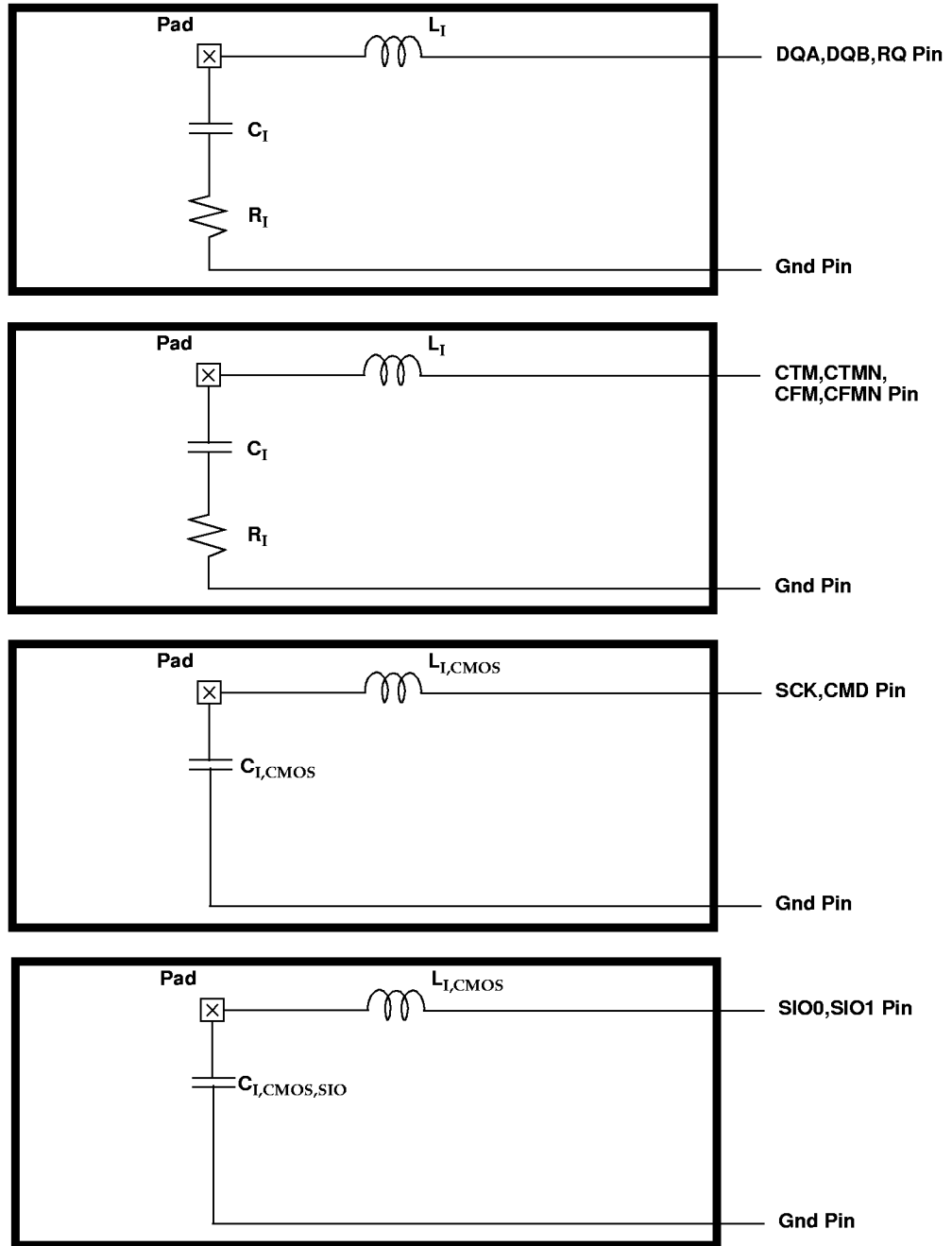

Figure 59: Equivalent Load Circuit for RSL Pins

This circuit does not include pin coupling effects that are often present in the packaged device. Because coupling effects make the effective single-pin induc-

tance  $L_I$ , and capacitance  $C_I$ , a function of neighboring pins, these parameters are intrinsically data-dependent. For purposes of specifying the device electrical

loading on the Channel, the effective  $L_I$  and  $C_I$  are defined as the worst-case values over all specified operating conditions.

$L_I$  is defined as the effective pin inductance based on the device pin assignment. Because the pad assignment places each RSL signal adjacent to an AC ground (a Gnd or Vdd pin), the effective inductance must be defined based on this configuration. Therefore,  $L_I$

assumes a loop with the RSL pin adjacent to an AC ground.

$C_I$  is defined as the effective pin capacitance based on the device pin assignment. It is the sum of the effective package pin capacitance and the IO pad capacitance.

**Table 25: RSL Pin Parasitics**

Symbol	Parameter and Conditions - RSL pins	Min	Max	Unit
$L_I$	RSL effective input inductance		4.0	nH
$L_{12}$	Mutual inductance between any DQA or DQB RSL signals.		0.2	nH
	Mutual inductance between any ROW or COL RSL signals.		0.6	nH
$C_I$	RSL effective input capacitance <sup>a</sup>	2.0	2.4	pF
$C_{12}$	Mutual capacitance between any RSL signals.	-	0.1	pF
$\Delta C_I$	Difference in $C_I$ value between any RSL pins of a single device.	-	0.04	pF
$R_I$	RSL effective input resistance	5	15	$\Omega$

a. This value is a combination of the device IO circuitry and package capacitances.

**Table 26: CMOS Pin Parasitics**

Symbol	Parameter and Conditions - CMOS pins	Min	Max	Unit
$L_{I,CMOS}$	CMOS effective input inductance		8.0	nH
$C_{I,CMOS}$	CMOS effective input capacitance (SCK,CMD) <sup>a</sup>	1.7	2.1	pF
$C_{I,CMOS,SIO}$	CMOS effective input capacitance (SIO1, SIO0) <sup>a</sup>	-	7.0	pF

a. This value is a combination of the device IO circuitry and package capacitances.

Edge-Bonded uBGA Package

Scale Package (CSP) device class.

Figure 60 shows the form and dimensions of the recommended package for the edge-bonded Chip

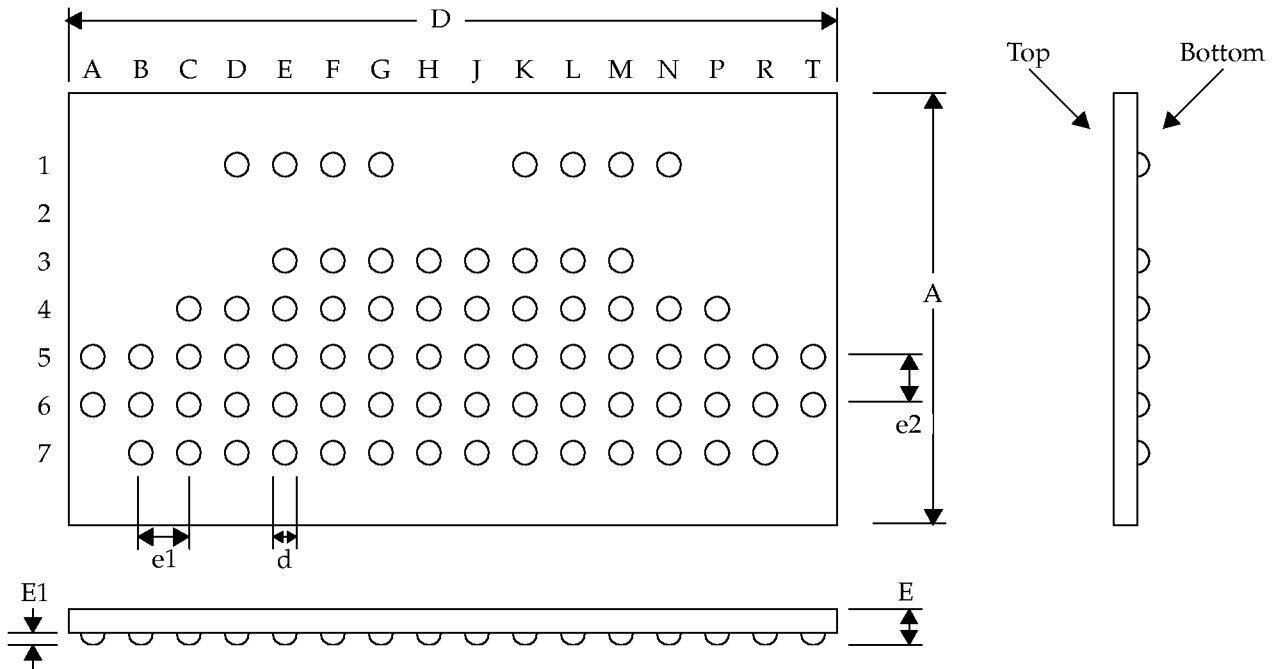

Figure 60: Edge-Bonded uBGA Package

Table 27: Edge-Bonded uBGA Package Dimensions

Table 27 lists the numerical values corresponding to dimensions shown in Figure 60.

Symbol	Parameter	Min	Max	Unit
e1	Ball pitch (x-axis)	0.75	0.75	mm
e2	Ball pitch (y-axis)	0.75	0.75	mm
A	Package body length	note <sup>a</sup>	note <sup>a</sup>	-
D	Package body width	note <sup>a</sup>	note <sup>a</sup>	-
E	Package total thickness	0.65	1.20	mm
E1	Ball height	0.20	0.43	mm
d	Ball diameter	0.33	0.50	mm

a. Package length and width vary with die size for chip scale packages.

### Center-Bonded uBGA Package

Figure 61 shows the form and dimensions of the recommended package for the center-bonded CSP device class.

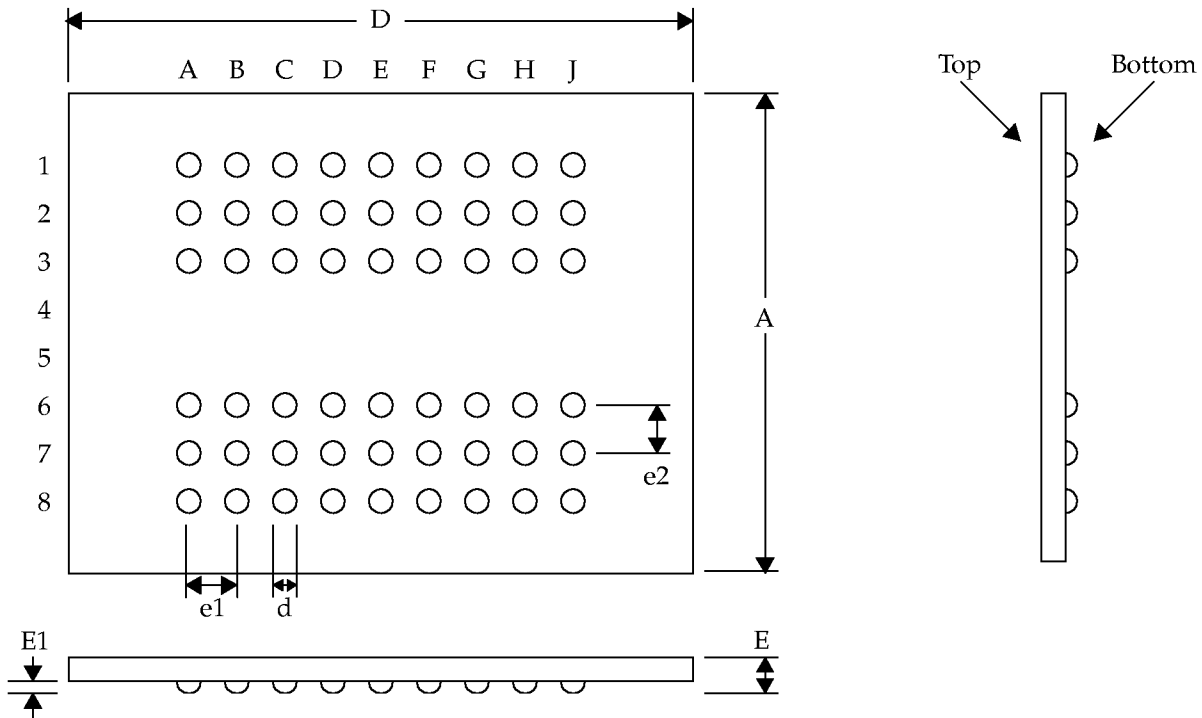

Figure 61: Center-Bonded uBGA Package

Table 28 lists the numerical values corresponding to dimensions shown in Figure 61.

Table 28: Center-Bonded uBGA Package Dimensions

Symbol	Parameter	Min	Max	Unit
e1	Ball pitch (x-axis)	1.00	1.00	mm
e2	Ball pitch (y-axis)	0.8	0.8	mm
A	Package body length	note <sup>a</sup>	note <sup>a</sup>	-
D	Package body width	note <sup>a</sup>	note <sup>a</sup>	-
E	Package total thickness	0.65	1.20	mm
E1	Ball height	0.20	0.43	mm
d	Ball diameter	0.33	0.50	mm

a. Package length and width vary with die size for chip scale packages.

## Glossary of Terms

<b>ACT</b>	Activate command from AV field.	<b>controller</b>	A logic-device which drives the ROW/COL /DQ wires for a Channel of RDRAMs.
<b>activate</b>	To access a row and place in sense amp.	<b>COP</b>	Column opcode field in COLC packet.
<b>adjacent</b>	Two RDRAM banks which share sense amps (also called doubled banks).	<b>core</b>	The banks and sense amps of an RDRAM.
<b>ASYM</b>	CCA register field for RSL $V_{OL}/V_{OH}$ .	<b>CTM,CTMN</b>	Clock pins for transmitting packets.
<b>ATTN</b>	Power state - ready for ROW/COL packets.	<b>current control</b>	Periodic operations to update the proper $I_{OL}$ value of RSL output drivers.
<b>ATTNR</b>	Power state - transmitting Q packets.	<b>D</b>	Write data packet on DQ pins.
<b>ATTNW</b>	Power state - receiving D packets.	<b>DBL</b>	CNFGB register field - doubled-bank.
<b>AV</b>	Opcode field in ROW packets.	<b>DC</b>	Device address field in COLC packet.
<b>bank</b>	A block of $2^{RBIT} \cdot 2^{CBIT}$ storage cells in the core of the RDRAM.	<b>device</b>	An RDRAM on a Channel.
<b>BC</b>	Bank address field in COLC packet.	<b>DEVID</b>	Control register with device address that is matched against DR, DC, and DX fields.
<b>BBIT</b>	CNFGA register field - # bank address bits.	<b>DM</b>	Device match for ROW packet decode.
<b>broadcast</b>	An operation executed by all RDRAMs.	<b>doubled-bank</b>	RDRAM with shared sense amp.
<b>BR</b>	Bank address field in ROW packets.	<b>DQ</b>	DQA and DQB pins.
<b>bubble</b>	Idle cycle(s) on RDRAM pins needed because of a resource constraint.	<b>DQA</b>	Pins for data byte A.
<b>BYT</b>	CNFGB register field - 8/9 bits per byte.	<b>DQB</b>	Pins for data byte B.
<b>BX</b>	Bank address field in COLX packet.	<b>DQS</b>	NAPX register field - PDN/NAP exit.
<b>C</b>	Column address field in COLC packet.	<b>DR,DR4T,DR4F</b>	Device address field and packet framing fields in ROWA and ROWR packets.
<b>CAL</b>	Calibrate ( $I_{OL}$ ) command in XOP field.	<b>dualoct</b>	16 bytes - the smallest addressable datum.
<b>CBIT</b>	CNFGB register field - # column address bits.	<b>DX</b>	Device address field in COLX packet.
<b>CCA</b>	Control register - current control A.	<b>field</b>	A collection of bits in a packet.
<b>CCB</b>	Control register - current control B.	<b>INIT</b>	Control register with initialization fields.
<b>CFM,CFMN</b>	Clock pins for receiving packets.	<b>initialization</b>	Configuring a Channel of RDRAMs so they are ready to respond to transactions.
<b>Channel</b>	ROW/COL/DQ pins and external wires.	<b>LSR</b>	CNFGA register field - low-power self-refresh.
<b>CLRR</b>	Clear reset command from SOP field.	<b>M</b>	Mask opcode field (COLM/COLX packet).
<b>CMD</b>	CMOS pin for initialization/power control.	<b>MA</b>	Field in COLM packet for masking byte A.
<b>CNFGA</b>	Control register with configuration fields.	<b>MB</b>	Field in COLM packet for masking byte B.
<b>CNFGB</b>	Control register with configuration fields.	<b>MSK</b>	Mask command in M field.
<b>COL</b>	Pins for column-access control.	<b>MVER</b>	Control register - manufacturer ID.
<b>COL</b>	COLC,COLM,COLX packet on COL pins.	<b>NAP</b>	Power state - needs SCK/CMD wakeup.
<b>COLC</b>	Column operation packet on COL pins.	<b>NAPR</b>	Nap command in ROP field.
<b>COLM</b>	Write mask packet on COL pins.	<b>NAPRC</b>	Conditional nap command in ROP field.
<b>column</b>	Rows in a bank or activated row in sense amps have $2^{CBIT}$ dualocts column storage.	<b>NAPXA</b>	NAPX register field - NAP exit delay A.
<b>command</b>	A decoded bit-combination from a field.	<b>NAPXB</b>	NAPX register field - NAP exit delay B.
<b>COLX</b>	Extended operation packet on COL pins.	<b>NOCOP</b>	No-operation command in COP field.
		<b>NOROP</b>	No-operation command in ROP field.

<b>NOXOP</b>	No-operation command in XOP field.	<b>ROWR</b>	Row operation packet on ROW pins.
<b>NSR</b>	INIT register field- NAP self-refresh.	<b>RQ</b>	Alternate name for ROW/COL pins.
<b>packet</b>	A collection of bits carried on the Channel.	<b>RSL</b>	Rambus Signaling Levels.
<b>PDN</b>	Power state - needs SCK/CMD wakeup.	<b>SAM</b>	Sample ( $I_{OL}$ ) command in XOP field.
<b>PDNR</b>	Powerdown command in ROP field.	<b>SA</b>	Serial address packet for control register transactions w/ SA address field.
<b>PDNXA</b>	Control register - PDN exit delay A.	<b>SBC</b>	Serial broadcast field in SRQ.
<b>PDNXB</b>	Control register - PDN exit delay B.	<b>SCK</b>	CMOS clock pin..
<b>pin efficiency</b>	The fraction of non-idle cycles on a pin.	<b>SD</b>	Serial data packet for control register transactions w/ SD data field.
<b>PRE</b>	PREC,PRER,PREX precharge commands.	<b>SDEV</b>	Serial device address in SRQ packet.
<b>PREC</b>	Precharge command in COP field.	<b>SDEVID</b>	INIT register field - Serial device ID.
<b>precharge</b>	Prepares sense amp and bank for activate.	<b>self-refresh</b>	Refresh mode for PDN and NAP.
<b>PRER</b>	Precharge command in ROP field.	<b>sense amp</b>	Fast storage that holds copy of bank's row.
<b>PREX</b>	Precharge command in XOP field.	<b>SETF</b>	Set fast clock command from SOP field.
<b>PSX</b>	INIT register field - PDN/NAP exit.	<b>SETR</b>	Set reset command from SOP field.
<b>PSR</b>	INIT register field - PDN self-refresh.	<b>SINT</b>	Serial interval packet for control register read/write transactions.
<b>PVER</b>	CNFGB register field - protocol version.	<b>SIO0,SIO1</b>	CMOS serial pins for control registers.
<b>Q</b>	Read data packet on DQ pins.	<b>SOP</b>	Serial opcode field in SRQ.
<b>R</b>	Row address field of ROWA packet.	<b>SRD</b>	Serial read opcode command from SOP.
<b>RBIT</b>	CNFGB register field - # row address bits.	<b>SRP</b>	INIT register field - Serial repeat bit.
<b>RD/RDA</b>	Read (/precharge) command in COP field.	<b>SRQ</b>	Serial request packet for control register read/write transactions.
<b>read</b>	Operation of accessing sense amp data.	<b>STBY</b>	Power state - ready for ROW packets.
<b>receive</b>	Moving information from the Channel into the RDRAM (a serial stream is demuxed).	<b>SVER</b>	Control register - stepping version.
<b>REFA</b>	Refresh-activate command in ROP field.	<b>SWR</b>	Serial write opcode command from SOP.
<b>REFB</b>	Control register - next bank (self-refresh).	<b>TCAS</b>	TCLSCAS register field - $t_{CAS}$ core delay.
<b>REFBIT</b>	CNFGB register field - ignore bank bits (for REFA and self-refresh).	<b>TCLS</b>	TCLSCAS register field - $t_{CLS}$ core delay.
<b>REFP</b>	Refresh-precharge command in ROP field.	<b>TCLSCAS</b>	Control register - $t_{CAS}$ and $t_{CLS}$ delays.
<b>REFR</b>	Control register - next row for REFA.	<b>TCYCLE</b>	Control register - $t_{CYCLE}$ delay.
<b>refresh</b>	Periodic operations to restore storage cells.	<b>TDAC</b>	Control register - $t_{DAC}$ delay.
<b>retire</b>	The automatic operation that stores write buffer into sense amp after WR command.	<b>TEST77</b>	Control register - for test purposes.
<b>RLX</b>	RLXC,RLXR,RLXX relax commands.	<b>TEST78</b>	Control register - for test purposes.
<b>RLXC</b>	Relax command in COP field.	<b>TRDLY</b>	Control register - $t_{RDLY}$ delay.
<b>RLXR</b>	Relax command in ROP field.	<b>transaction</b>	ROW,COL,DQ packets for memory access.
<b>RLXX</b>	Relax command in XOP field.	<b>transmit</b>	Moving information from the RDRAM onto the Channel (parallel word is muxed).
<b>ROP</b>	Row-opcode field in ROWR packet.	<b>WR/WRA</b>	Write (/precharge) command in COP field.
<b>row</b>	$2^{CBIT}$ dualocts of cells (bank/sense amp).	<b>write</b>	Operation of modifying sense amp data.
<b>ROW</b>	Pins for row-access control	<b>XOP</b>	Extended opcode field in COLX packet.
<b>ROW</b>	ROWA or ROWR packets on ROW pins.		
<b>ROWA</b>	Activate packet on ROW pins.		

**Table Of Contents**

Overview ..... 1  
 Features..... 1  
 Key Timing Parameters/Part Numbers ..... 1  
 Pinouts and Definitions ..... 2  
 Pin Description..... 3  
 Block Diagram ..... 4  
 General Description ..... 5  
 Packet Format ..... 6,7  
 Field Encoding Summary..... 8,9  
 DQ Packet Timing ..... 10  
 COLM Packet to D Packet Mapping ..... 10,11  
 ROW-to-ROW Packet Interaction ..... 12, 13  
 ROW-to-COL Packet Interaction ..... 13  
 COL-to-COL Packet Interaction..... 14  
 COL-to-ROW Packet Interaction ..... 15  
 ROW-to-ROW Examples ..... 16,17  
 Row and Column Cycle Description ..... 17  
 Precharge Mechanisms ..... 18,19  
 Read Transaction - Example ..... 20  
 Write Transaction - Example ..... 21  
 Write/Retire - Examples ..... 22, 23  
 Interleaved Write - Example..... 24  
 Interleaved Read - Example ..... 25  
 Interleaved RRWW ..... 25  
 Control Register Transactions ..... 26  
 Control Register Packets ..... 27  
 Initialization ..... 28-29  
 Control Register Summary..... 30-37  
 Power State Management ..... 38-41  
 Refresh ..... 42  
 Current and Temperature Control ..... 43  
 Electrical Conditions ..... 44  
 Timing Conditions ..... 44-45  
 Electrical Characteristics ..... 46  
 Timing Characteristics ..... 46  
 RSL Clocking..... 47  
 RSL - Receive Timing ..... 48  
 RSL - Transmit Timing ..... 49  
 CMOS - Receive Timing ..... 50-51  
 CMOS - Transmit Timing ..... 52-53  
 RSL - Domain Crossing Window ..... 53  
 Timing Parameters..... 54  
 Absolute Maximum Ratings ..... 55

I<sub>DD</sub> - Supply Current Profile ..... 55  
 Capacitance and Inductance ..... 56-57  
 Edge-Bonded mBGA Package ..... 58  
 Edge-Bonded mBGA Package ..... 59  
 Glossary of Terms ..... 60-61

*Written by: Frederick A. Ware*