

---

# HB56UW872EJK Series

8,388,608-word  $\times$  72-bit High Density Dynamic RAM Module

# HITACHI

ADE-203-720A (Z)

Rev. 1.0

Jan. 27, 1997

---

## Description

The HB56UW872EJK belongs to 8 Byte DIMM (Dual In-line Memory Module) family, and has been developed as an optimized main memory solution for 4 and 8 Byte processor applications. The HB56UW872EJK is a 8M  $\times$  72 dynamic RAM module, mounted 36 pieces of 16-Mbit DRAM (HM51W16405) sealed in SOJ package and 2 pieces of 16-bit BiCMOS line driver (74LVT16244) sealed in TSSOP package. The HB56UW872EJK offers Extended Data Out (EDO) Page Mode as a high speed access mode. An outline of the HB56UW872EJK is 168-pin socket type package (dual lead out). Therefore, the HB56UW872EJK makes high density mounting possible without surface mount technology. The HB56UW872EJK provides common data inputs and outputs. Decoupling capacitors are mounted on the module board.

## Features

- 168-pin socket type package (Dual lead out)
  - Outline: 133.35 mm (Length)  $\times$  38.10 mm (Height)  $\times$  9.00 mm (Thickness)
  - Lead pitch: 1.27 mm
- Single 3.3 V ( $\pm 0.3$  V) supply
- High speed
  - Access time:  $t_{RAC} = 50/60/70$  ns (max)
  - $t_{CAC} = 18/20/23$  ns (max)
- Low power dissipation
  - Active mode: 6.19/5.54/4.90 W (max)
  - Standby mode (TTL): 295.2 mW (max)
  - (CMOS): 165.6 mW (max)
- Buffered input except  $\overline{RAS}$  and DQ
- 4 byte interleave enabled, dual address input (A0/B0)
- JEDEC standard outline buffered 8-byte DIMM
- EDO page mode capability
- 4,096 refresh cycles: 64 ms
- 2 variations of refresh
  - $\overline{RAS}$ -only refresh
  - $\overline{CAS}$ -before- $\overline{RAS}$  refresh

---

## **HB56UW872EJK Series**

---

### **Ordering Information**

<b>Type No.</b>	<b>Access time</b>	<b>Package</b>	<b>Contact pad</b>
HB56UW872EJK-5	50 ns	168-pin dual lead out socket type	Gold
HB56UW872EJK-6	60 ns		
HB56UW872EJK-7	70 ns		

---

## HB56UW872EJK Series

### Pin Arrangement

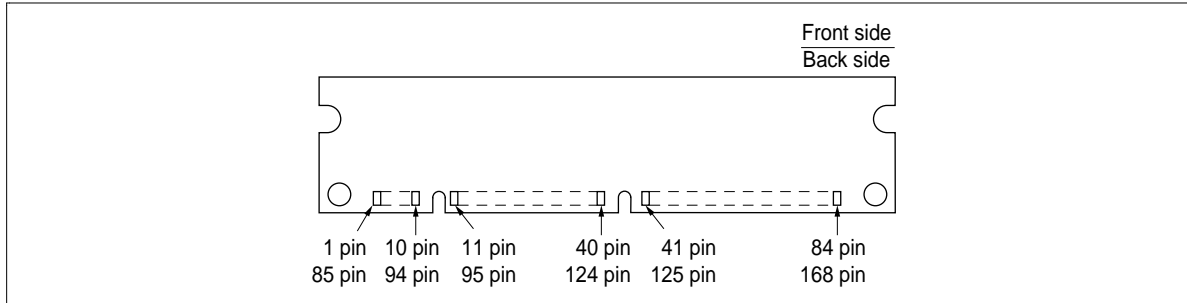

### Pin Arrangement

Pin No.	Pin name	Pin No.	Pin name	Pin No.	Pin name	Pin No.	Pin name
1	V <sub>SS</sub>	43	V <sub>SS</sub>	85	V <sub>SS</sub>	127	V <sub>SS</sub>
2	DQ0	44	$\overline{\text{OE2}}$	86	DQ36	128	NC
3	DQ1	45	$\overline{\text{RE2}}$	87	DQ37	129	$\overline{\text{RE3}}$
4	DQ2	46	$\overline{\text{CE4}}$	88	DQ38	130	$\overline{\text{CE5}}$
5	DQ3	47	NC	89	DQ39	131	NC
6	V <sub>CC</sub>	48	$\overline{\text{WE2}}$	90	V <sub>CC</sub>	132	$\overline{\text{PDE}}$
7	DQ4	49	V <sub>CC</sub>	91	DQ40	133	V <sub>CC</sub>
8	DQ5	50	NC	92	DQ41	134	NC
9	DQ6	51	NC	93	DQ42	135	NC
10	DQ7	52	DQ18	94	DQ43	136	DQ54
11	DQ8	53	DQ19	95	DQ44	137	DQ55
12	V <sub>SS</sub>	54	V <sub>SS</sub>	96	V <sub>SS</sub>	138	V <sub>SS</sub>
13	DQ9	55	DQ20	97	DQ45	139	DQ56
14	DQ10	56	DQ21	98	DQ46	140	DQ57
15	DQ11	57	DQ22	99	DQ47	141	DQ58
16	DQ12	58	DQ23	100	DQ48	142	DQ59
17	DQ13	59	V <sub>CC</sub>	101	DQ49	143	V <sub>CC</sub>
18	V <sub>CC</sub>	60	DQ24	102	V <sub>CC</sub>	144	DQ60
19	DQ14	61	NC	103	DQ50	145	NC
20	DQ15	62	NC	104	DQ51	146	NC
21	DQ16	63	NC	105	DQ52	147	NC
22	DQ17	64	NC	106	DQ53	148	NC
23	V <sub>SS</sub>	65	DQ25	107	V <sub>SS</sub>	149	DQ61
24	NC	66	DQ26	108	NC	150	DQ62
25	NC	67	DQ27	109	NC	151	DQ63

## HB56UW872EJK Series

Pin No.	Pin name	Pin No.	Pin name	Pin No.	Pin name	Pin No.	Pin name
26	V <sub>CC</sub>	68	V <sub>SS</sub>	110	V <sub>CC</sub>	152	V <sub>SS</sub>
27	$\overline{WE0}$	69	DQ28	111	NC	153	DQ64
28	$\overline{CE0}$	70	DQ29	112	$\overline{CE1}$	154	DQ65
29	NC	71	DQ30	113	NC	155	DQ66
30	$\overline{RE0}$	72	DQ31	114	$\overline{RE1}$	156	DQ67
31	$\overline{OE0}$	73	V <sub>CC</sub>	115	NC	157	V <sub>CC</sub>
32	V <sub>SS</sub>	74	DQ32	116	V <sub>SS</sub>	158	DQ68
33	A0	75	DQ33	117	A1	159	DQ69
34	A2	76	DQ34	118	A3	160	DQ70
35	A4	77	DQ35	119	A5	161	DQ71
36	A6	78	V <sub>SS</sub>	120	A7	162	V <sub>SS</sub>
37	A8	79	PD1	121	A9	163	PD2
38	A10	80	PD3	122	A11	164	PD4
39	NC	81	PD5	123	NC	165	PD6
40	V <sub>CC</sub>	82	PD7	124	V <sub>CC</sub>	166	PD8
41	NC	83	ID0 (V <sub>SS</sub> )	125	NC	167	ID1 (V <sub>SS</sub> )
42	NC	84	V <sub>CC</sub>	126	B0	168	V <sub>CC</sub>

## Pin Description

Pin name	Function
A0 to A11, B0	Address input <ul style="list-style-type: none"> <li>• Row address : A0 to A11, B0</li> <li>• Column address : A0 to A9, B0</li> <li>• Refresh address : A0 to A11, B0</li> </ul>
DQ0 to DQ71	Data-in/data-out
$\overline{RE0}$ to $\overline{RE3}$	Row address strobe ( $\overline{RAS}$ )
$\overline{CE0}$ , $\overline{CE1}$ , $\overline{CE4}$ , $\overline{CE5}$	Column address strobe ( $\overline{CAS}$ )
$\overline{WE0}$ , $\overline{WE2}$	Read/Write enable
$\overline{OE0}$ , $\overline{OE2}$	Output enable
V <sub>CC</sub>	Power supply
V <sub>SS</sub>	Ground
PD1 to PD8	Presence detect
ID0, ID1	ID bit
$\overline{PDE}$	Presence detect enable
NC	No connection

---

**HB56UW872EJK Series**

---

**Presence Detect Pin Assignment**

Pin name	Pin No.	$\overline{\text{PDE}} = \text{Low}$			$\overline{\text{PDE}} = \text{High}$
		50 ns	60 ns	70 ns	All
PD1	79	0	0	0	High-Z
PD2	163	0	0	0	High-Z
PD3	80	1	1	1	High-Z
PD4	164	1	1	1	High-Z
PD5	81	1	1	1	High-Z
PD6	165	0	1	0	High-Z
PD7	82	0	1	1	High-Z
PD8	166	0	0	0	High-Z

Note: 1: High level (Driver output)

0: Low level (Driver output)

# HB56UW872EJK Series

## Block Diagram

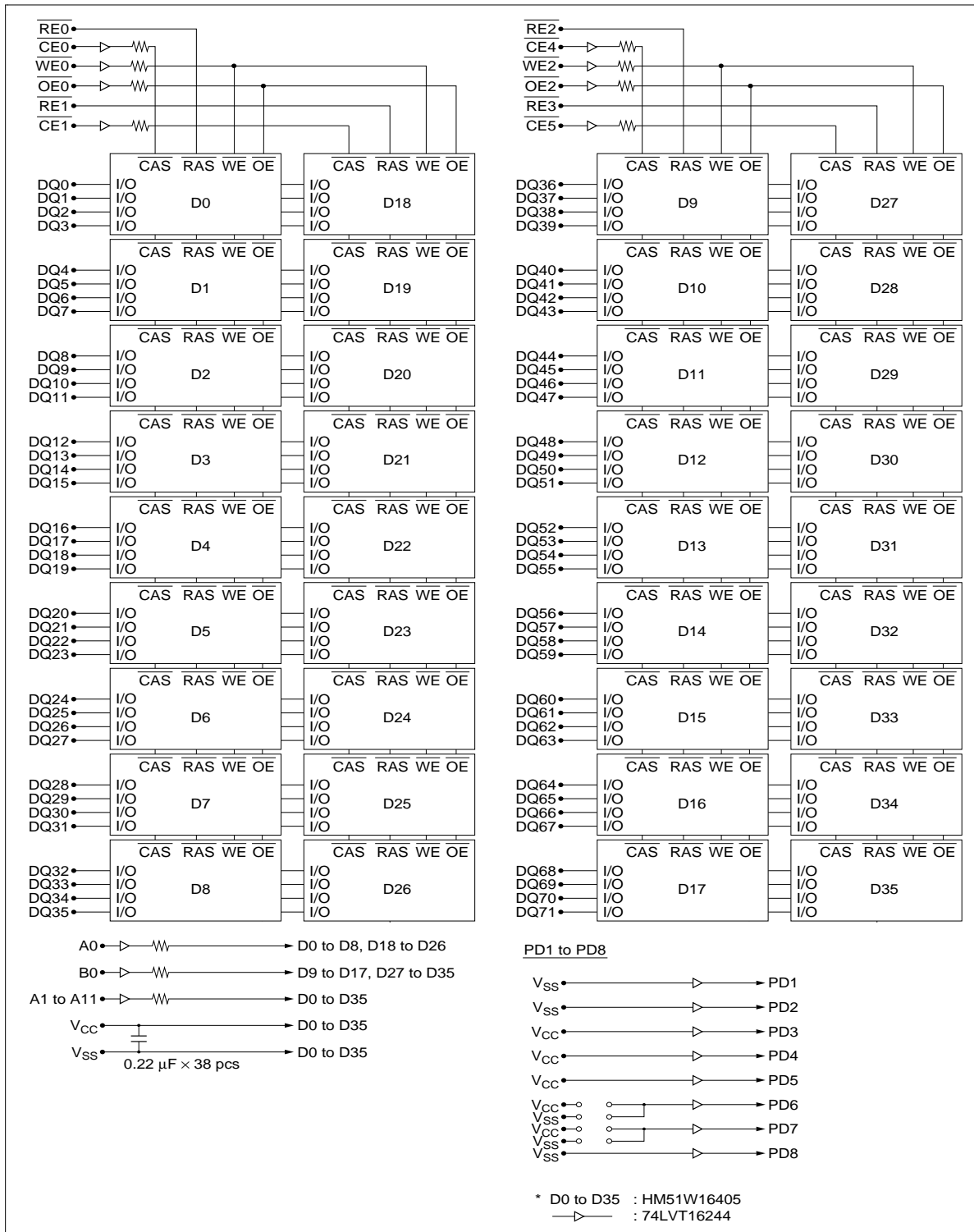

---

---

## HB56UW872EJK Series

---

### Absolute Maximum Ratings

Parameter	Symbol	Value	Unit
Voltage on any pin relative to $V_{SS}$	$V_T$	-0.5 to +4.6	V
Supply voltage relative to $V_{SS}$	$V_{CC}$	-0.5 to +4.6	V
Short circuit output current	$I_{out}$	50	mA
Power dissipation	$P_t$	19	W
Operating temperature	$T_{opr}$	0 to +70	°C
Storage temperature	$T_{stg}$	-55 to +125	°C

### Recommended DC Operating Conditions ( $T_a = 0$ to $70^\circ\text{C}$ )

Parameter	Symbol	Min	Type	Max	Unit	Note
Supply voltage	$V_{SS}$	0	0	0	V	
	$V_{CC}$	3.0	3.3	3.6	V	1
Input high voltage	$V_{IH}$	2.0	—	$V_{CC} + 0.3$	V	1
Input low voltage	$V_{IL}$	-0.3	—	0.8	V	1

Note: 1. All voltage referenced to  $V_{SS}$ .

## HB56UW872EJK Series

**DC Characteristics** ( $T_a = 0$  to  $70^\circ\text{C}$ ,  $V_{CC} = 3.3\text{ V} \pm 0.3\text{ V}$ ,  $V_{SS} = 0\text{ V}$ )

Parameter	Symbol	50 ns		60 ns		70 ns		Unit	Test conditions	Notes
		Min	Max	Min	Max	Min	Max			
Operating current	$I_{CC1}$	—	1720	—	1540	—	1360	mA	$t_{RC} = \text{min}$	1, 2
Standby current	$I_{CC2}$	—	82	—	82	—	82	mA	TTL interface $\overline{\text{RAS}}, \overline{\text{CAS}} = V_{IH}$ Dout = High-Z	
		—	46	—	46	—	46	mA	CMOS interface $\overline{\text{RAS}}, \overline{\text{CAS}} \geq V_{CC} - 0.2\text{ V}$ Dout = High-Z	
$\overline{\text{RAS}}$ -only refresh current	$I_{CC3}$	—	1720	—	1540	—	1360	mA	$t_{RC} = \text{min}$	2
Standby current	$I_{CC5}$	—	190	—	190	—	190	mA	$\overline{\text{RAS}} = V_{IH}, \overline{\text{CAS}} = V_{IL}$ Dout = enable	1
$\overline{\text{CAS}}$ -before- $\overline{\text{RAS}}$ refresh current	$I_{CC6}$	—	1720	—	1540	—	1360	mA	$t_{RC} = \text{min}$	
EDO page mode current	$I_{CC7}$	—	1540	—	1360	—	1270	mA	$t_{HPC} = \text{min}$	1, 3
Input leakage current	$I_{LI}$	-10	10	-10	10	-10	10	$\mu\text{A}$	$0\text{ V} \leq V_{in} \leq 4.6\text{ V}$	
Output leakage current	$I_{LO}$	-10	10	-10	10	-10	10	$\mu\text{A}$	$0\text{ V} \leq V_{out} \leq 4.6\text{ V}$ Dout = disable	
Output high voltage	$V_{OH}$	2.4	$V_{CC}$	2.4	$V_{CC}$	2.4	$V_{CC}$	V	High Iout = -2 mA	
Output low voltage	$V_{OL}$	0	0.4	0	0.4	0	0.4	V	Low Iout = 2 mA	

Notes: 1.  $I_{CC}$  depends on output load condition when the device is selected,  $I_{CC}$  max is specified at the output open condition.

2. Address can be changed once or less while  $\overline{\text{RAS}} = V_{IL}$ .

3. Address can be changed once or less while  $\overline{\text{CAS}} = V_{IH}$ .

**Capacitance** ( $T_a = 25^\circ\text{C}$ ,  $V_{CC} = 3.3\text{ V} \pm 0.3\text{ V}$ )

Parameter	Symbol	Type	Max	Unit	Notes
Input capacitance (Address)	$C_{I1}$	—	20	pF	1
Input capacitance ( $\overline{\text{CAS}}, \overline{\text{WE}}, \overline{\text{OE}}$ )	$C_{I2}$	—	20	pF	1
Input capacitance ( $\overline{\text{RAS}}$ )	$C_{I3}$	—	108	pF	1
I/O capacitance (DQ)	$C_{I/O}$	—	34	pF	1, 2

Notes: 1. Capacitance measured with Boonton Meter or effective capacitance measuring method.

2.  $\overline{\text{CAS}} = V_{IH}$  to disable Dout.

## HB56UW872EJK Series

**AC Characteristics** ( $T_a = 0$  to  $70^\circ\text{C}$ ,  $V_{CC} = 3.3 \text{ V} \pm 0.3 \text{ V}$ ,  $V_{SS} = 0 \text{ V}$ )<sup>\*1, \*2, \*18, \*19</sup>

### Test Conditions

- Input rise and fall times: 2 ns
- Input levels: 0 V, 3.0 V
- Input timing reference levels: 0.8 V, 2.0 V
- Output timing reference levels: 0.8 V, 2.0 V
- Output load: 1 TTL gate +  $C_L$  (100 pF) (Including scope and jig)

### Read, Write, Read-Modify-Write and Refresh Cycles (Common parameters)

Parameter	Symbol	50 ns		60 ns		70 ns		Unit	Notes
		Min	Max	Min	Max	Min	Max		
Random read or write cycle time	$t_{RC}$	84	—	104	—	124	—	ns	
$\overline{\text{RAS}}$ precharge time	$t_{RP}$	30	—	40	—	50	—	ns	
$\overline{\text{CAS}}$ precharge time	$t_{CP}$	8	—	10	—	13	—	ns	
$\overline{\text{RAS}}$ pulse width	$t_{RAS}$	50	10000	60	10000	70	10000	ns	
$\overline{\text{CAS}}$ pulse width	$t_{CAS}$	8	10000	10	10000	13	10000	ns	
Row address setup time	$t_{ASR}$	5	—	5	—	5	—	ns	
Row address hold time	$t_{RAH}$	8	—	10	—	10	—	ns	
Column address setup time	$t_{ASC}$	0	—	0	—	0	—	ns	
Column address hold time	$t_{CAH}$	8	—	10	—	13	—	ns	
$\overline{\text{RAS}}$ to $\overline{\text{CAS}}$ delay time	$t_{RCD}$	12	32	14	40	14	47	ns	3
$\overline{\text{RAS}}$ to column address delay time	$t_{RAD}$	10	20	12	25	12	30	ns	4
$\overline{\text{RAS}}$ hold time	$t_{RSH}$	15	—	18	—	18	—	ns	
$\overline{\text{CAS}}$ hold time	$t_{CSH}$	35	—	40	—	45	—	ns	
$\overline{\text{CAS}}$ to $\overline{\text{RAS}}$ precharge time	$t_{CRP}$	10	—	10	—	10	—	ns	
$\overline{\text{OE}}$ to Din delay time	$t_{OED}$	18	—	20	—	23	—	ns	5
$\overline{\text{OE}}$ delay time from Din	$t_{DZO}$	0	—	0	—	0	—	ns	6
$\overline{\text{CAS}}$ delay time from Din	$t_{DZC}$	0	—	0	—	0	—	ns	6
Transition time (rise and fall) $t_T$	$t_T$	2	50	2	50	2	50	ns	7
Refresh period (4,096 cycles)	$t_{REF}$	—	64	—	64	—	64	ms	

## HB56UW872EJK Series

### Read Cycle

Parameter	Symbol	50 ns		60 ns		70 ns		Unit	Notes
		Min	Max	Min	Max	Min	Max		
Access time from $\overline{\text{RAS}}$	$t_{\text{RAC}}$	—	50	—	60	—	70	ns	8, 9
Access time from $\overline{\text{CAS}}$	$t_{\text{CAC}}$	—	18	—	20	—	23	ns	9, 10, 17
Access time from address	$t_{\text{AA}}$	—	30	—	35	—	40	ns	9, 11, 17
Access time from $\overline{\text{OE}}$	$t_{\text{OEA}}$	—	18	—	20	—	23	ns	9, 21
Read command setup time	$t_{\text{RCS}}$	0	—	0	—	0	—	ns	
Read command hold time to $\overline{\text{CAS}}$	$t_{\text{RCH}}$	0	—	0	—	0	—	ns	12
Read command hold time from $\overline{\text{RAS}}$	$t_{\text{RCHR}}$	50	—	60	—	70	—	ns	
Read command hold time to $\overline{\text{RAS}}$	$t_{\text{RRH}}$	5	—	5	—	5	—	ns	12
Column address to $\overline{\text{RAS}}$ lead time	$t_{\text{RAL}}$	30	—	35	—	40	—	ns	
Column address to $\overline{\text{CAS}}$ lead time	$t_{\text{CAL}}$	15	—	18	—	23	—	ns	
$\overline{\text{CAS}}$ to output in low-Z	$t_{\text{CLZ}}$	2	—	2	—	2	—	ns	
Output data hold time	$t_{\text{OH}}$	3	—	3	—	3	—	ns	22
Output data hold time from $\overline{\text{OE}}$	$t_{\text{OHO}}$	3	—	3	—	3	—	ns	
Output buffer turn-off time	$t_{\text{OFF}}$	—	18	—	20	—	20	ns	13, 22
Output buffer turn-off to $\overline{\text{OE}}$	$t_{\text{OEZ}}$	—	18	—	20	—	20	ns	13
$\overline{\text{CAS}}$ to Din delay time	$t_{\text{CDD}}$	18	—	20	—	23	—	ns	5
Output data hold time from $\overline{\text{RAS}}$	$t_{\text{OHR}}$	3	—	3	—	3	—	ns	22
Output buffer turn-off time to $\overline{\text{RAS}}$	$t_{\text{OFR}}$	—	13	—	15	—	15	ns	22
Output buffer turn-off to $\overline{\text{WE}}$	$t_{\text{WEZ}}$	—	18	—	20	—	20	ns	
$\overline{\text{WE}}$ to Din delay time	$t_{\text{WED}}$	18	—	20	—	23	—	ns	
$\overline{\text{RAS}}$ to Din delay time	$t_{\text{RDD}}$	13	—	15	—	18	—	ns	
$\overline{\text{RAS}}$ next $\overline{\text{CAS}}$ delay time	$t_{\text{RNCD}}$	50	—	60	—	70	—	ns	

## HB56UW872EJK Series

### Write Cycle

Parameter	Symbol	50 ns		60 ns		70 ns		Unit	Notes
		Min	Max	Min	Max	Min	Max		
Write command setup time	$t_{WCS}$	0	—	0	—	0	—	ns	14
Write command hold time	$t_{WCH}$	8	—	10	—	13	—	ns	
Write command pulse width	$t_{WCP}$	8	—	10	—	10	—	ns	
Write command to $\overline{RAS}$ lead time	$t_{RWL}$	13	—	15	—	18	—	ns	
Write command to $\overline{CAS}$ lead time	$t_{CWL}$	8	—	10	—	13	—	ns	
Data-in setup time	$t_{DS}$	0	—	0	—	0	—	ns	15
Data-in hold time	$t_{DH}$	13	—	15	—	18	—	ns	15

### Read-Modify-Write Cycle

Parameter	Symbol	50 ns		60 ns		70 ns		Unit	Notes
		Min	Max	Min	Max	Min	Max		
Read-modify-write cycle time	$t_{RWC}$	111	—	135	—	161	—	ns	
$\overline{RAS}$ to $\overline{WE}$ delay time	$t_{RWD}$	67	—	79	—	92	—	ns	14
$\overline{CAS}$ to $\overline{WE}$ delay time	$t_{CWD}$	30	—	34	—	40	—	ns	14
Column address to $\overline{WE}$ delay time	$t_{AWD}$	42	—	49	—	57	—	ns	14
$\overline{OE}$ hold time from $\overline{WE}$	$t_{OEH}$	13	—	15	—	18	—	ns	

### Refresh Cycle

Parameter	Symbol	50 ns		60 ns		70 ns		Unit	Notes
		Min	Max	Min	Max	Min	Max		
$\overline{CAS}$ setup time (CBR refresh cycle)	$t_{CSR}$	10	—	10	—	10	—	ns	
$\overline{CAS}$ hold time (CBR refresh cycle)	$t_{CHR}$	8	—	10	—	10	—	ns	
$\overline{WE}$ setup time (CBR refresh cycle)	$t_{WRP}$	5	—	5	—	5	—	ns	
$\overline{WE}$ hold time (CBR refresh cycle)	$t_{WRH}$	8	—	10	—	10	—	ns	
$\overline{RAS}$ precharge to $\overline{CAS}$ hold time	$t_{RPC}$	5	—	5	—	5	—	ns	

## HB56UW872EJK Series

### EDO Page Mode Cycle

Parameter	Symbol	50 ns		60 ns		70 ns		Unit	Notes
		Min	Max	Min	Max	Min	Max		
EDO page mode cycle time	$t_{\text{HPC}}$	20	—	25	—	30	—	ns	20
EDO page mode $\overline{\text{RAS}}$ pulse width	$t_{\text{RASP}}$	—	100000	—	100000	—	100000	ns	16
Access time from $\overline{\text{CAS}}$ precharge	$t_{\text{CPA}}$	—	35	—	40	—	45	ns	9, 17
$\overline{\text{RAS}}$ hold time from $\overline{\text{CAS}}$ precharge	$t_{\text{CPRH}}$	35	—	40	—	45	—	ns	
Output data hold time from $\overline{\text{CAS}}$ low	$t_{\text{DOH}}$	3	—	3	—	3	—	ns	9, 17
$\overline{\text{CAS}}$ hold time referred $\overline{\text{OE}}$	$t_{\text{COL}}$	8	—	10	—	13	—	ns	
$\overline{\text{CAS}}$ to $\overline{\text{OE}}$ setup time	$t_{\text{COP}}$	5	—	5	—	5	—	ns	
Read command hold time from $\overline{\text{CAS}}$ precharge	$t_{\text{RCHC}}$	30	—	35	—	40	—	ns	

**EDO Page Mode Read-Modify-Write Cycle**

Parameter	Symbol	50 ns		60 ns		70 ns		Unit	Notes
		Min	Max	Min	Max	Min	Max		
EDO page mode read-modify-write cycle time	$t_{\text{HPRWC}}$	57	—	68	—	79	—	ns	
$\overline{\text{WE}}$ delay time from $\overline{\text{CAS}}$ precharge	$t_{\text{CPW}}$	45	—	54	—	62	—	ns	14

- Notes:
- AC measurements assume  $t_r = 2$  ns.
  - An initial pause of 200  $\mu\text{s}$  is required after power up followed by a minimum of eight initialization cycles (any combination of cycles containing  $\overline{\text{RAS}}$ -only refresh cycle or  $\overline{\text{CAS}}$ -before- $\overline{\text{RAS}}$  refresh). If the internal refresh counter is used, a minimum of eight  $\overline{\text{CAS}}$ -before- $\overline{\text{RAS}}$  refresh cycles are required.
  - Operation with the  $t_{\text{RCD}}$  (max) limit insures that  $t_{\text{RAC}}$  (max) can be met,  $t_{\text{RCD}}$  (max) is specified as a reference point only; if  $t_{\text{RCD}} \geq t_{\text{RAD}} (\text{max}) + t_{\text{AA}} (\text{max}) - t_{\text{CAC}} (\text{max})$ , then access time is controlled exclusively by  $t_{\text{CAC}}$ .
  - Operation with the  $t_{\text{RAD}}$  (max) limit insures that  $t_{\text{RAC}}$  (max) can be met,  $t_{\text{RAD}}$  (max) is specified as a reference point only; if  $t_{\text{RAD}}$  is greater than the specified  $t_{\text{RAD}}$  (max) limit, then access time is controlled exclusively by  $t_{\text{AA}}$ .
  - Either  $t_{\text{OED}}$  or  $t_{\text{CDD}}$  must be satisfied.
  - Either  $t_{\text{DZO}}$  or  $t_{\text{DZC}}$  must be satisfied.
  - $V_{\text{IH}}$  (min) and  $V_{\text{IL}}$  (max) are reference levels for measuring timing of input signals. Also, transition times are measured between  $V_{\text{IH}}$  (min) and  $V_{\text{IL}}$  (max).
  - Assumes that  $t_{\text{RCD}} \leq t_{\text{RCD}} (\text{max})$  and  $t_{\text{RAD}} \leq t_{\text{RAD}} (\text{max})$ . If  $t_{\text{RCD}}$  or  $t_{\text{RAD}}$  is greater than the maximum recommended value shown in this table,  $t_{\text{RAC}}$  exceeds the value shown.
  - Measured with a load circuit equivalent to 1 TTL loads and 100 pF.
  - Assumes that  $t_{\text{RCD}} \geq t_{\text{RCD}} (\text{max})$  and  $t_{\text{RCD}} + t_{\text{CAC}} (\text{max}) \geq t_{\text{RAD}} + t_{\text{AA}} (\text{max})$ .
  - Assumes that  $t_{\text{RAD}} \geq t_{\text{RAD}} (\text{max})$  and  $t_{\text{RCD}} + t_{\text{CAC}} (\text{max}) \leq t_{\text{RAD}} + t_{\text{AA}} (\text{max})$ .
  - Either  $t_{\text{RCH}}$  or  $t_{\text{RRH}}$  must be satisfied for a read cycles.
  - $t_{\text{OFF}} (\text{max})$  and  $t_{\text{OEZ}} (\text{max})$  define the time at which the outputs achieve the open circuit condition and are not referred to output voltage levels.
  - $t_{\text{WCS}}$ ,  $t_{\text{RWd}}$ ,  $t_{\text{CWD}}$ ,  $t_{\text{AWD}}$ , and  $t_{\text{CPW}}$  are not restrictive operating parameters. They are included in the data sheet as electrical characteristics only; if  $t_{\text{WCS}} \geq t_{\text{WCS}} (\text{min})$ , the cycle is an early write cycle and the data out pin will remain open circuit (high impedance) throughout the entire cycle; if  $t_{\text{RWd}} \geq t_{\text{RWd}} (\text{min})$ ,  $t_{\text{CWD}} \geq t_{\text{CWD}} (\text{min})$ , and  $t_{\text{AWD}} \geq t_{\text{AWD}} (\text{min})$  or  $t_{\text{CWD}} \geq t_{\text{CWD}} (\text{min})$ ,  $t_{\text{AWD}} \geq t_{\text{AWD}} (\text{min})$  and  $t_{\text{CPW}} \geq t_{\text{CPW}} (\text{min})$ , the cycle is a read-modify-write and the data output will contain data read from the selected cell; if neither of the above sets of conditions is satisfied, the condition of the data out (at access time) is indeterminate.
  - These parameters are referred to  $\overline{\text{CAS}}$  leading edge in early write cycles and to  $\overline{\text{WE}}$  leading edge in delayed write or read-modify-write cycles.
  - $t_{\text{RASP}}$  defines  $\overline{\text{RAS}}$  pulse width in EDO page mode cycles.
  - Access time is determined by the longest among  $t_{\text{AA}}$ ,  $t_{\text{CAC}}$  and  $t_{\text{CPA}}$ .
  - In delayed write or read-modify-write cycles,  $\overline{\text{OE}}$  must disable output buffer prior to applying data to the device. After  $\overline{\text{RAS}}$  is reset, if  $t_{\text{OEH}} \geq t_{\text{CWL}}$ , the DQ pin will remain open circuit (high impedance);  $t_{\text{OEH}} < t_{\text{OEH}}$ , invalid data will be out at each DQ.
  - All the  $V_{\text{CC}}$  and  $V_{\text{SS}}$  pins shall be supplied with the same voltages.

---

## HB56UW872EJK Series

---

20.  $t_{\text{HPC}}$  (min) can be achieved during a series of EDO page mode write cycles or EDO page mode read cycles. If both write and read operation are mixed in a EDO page mode  $\overline{\text{RAS}}$  cycle (EDO page mode mix cycle (1), (2)), minimum value of  $\overline{\text{CAS}}$  cycle ( $t_{\text{CAS}} + t_{\text{CP}} + 2t_{\text{T}}$ ) becomes greater than the specified  $t_{\text{HPC}}$  (min) value. The value of  $\overline{\text{CAS}}$  cycle time of mixed EDO page mode is shown in EDO page mode mix cycle (1) and (2).
21. When output buffers are enabled once, sustain the low impedance state until valid data is obtained. When output buffer is turned on and off within a very short time, generally it causes large  $V_{\text{CC}} / V_{\text{SS}}$  line noise, which causes to degrade  $V_{\text{IH}}$  min./  $V_{\text{IL}}$  max level.
22. Data output turns off and becomes high impedance from later rising edge of  $\overline{\text{RAS}}$  and  $\overline{\text{CAS}}$ . Hold time and turn off time are specified by the timing specifications of later rising edge of  $\overline{\text{RAS}}$  and  $\overline{\text{CAS}}$  between  $t_{\text{OHR}}$  and  $t_{\text{OH}}$ , and between  $t_{\text{OFR}}$  and  $t_{\text{OFF}}$ .
23. XXX: H or L (H:  $V_{\text{IH}}(\text{min}) \leq V_{\text{IN}} \leq V_{\text{IH}}(\text{max})$ , L:  $V_{\text{IL}}(\text{min}) \leq V_{\text{IN}} \leq V_{\text{IL}}(\text{max})$ )  
////////: Invalid Dout  
When the address, clock and input pins are not described on timing waveforms, their pins must be applied  $V_{\text{IH}}$  or  $V_{\text{IL}}$ .

Timing Waveforms\*23

Read Cycle

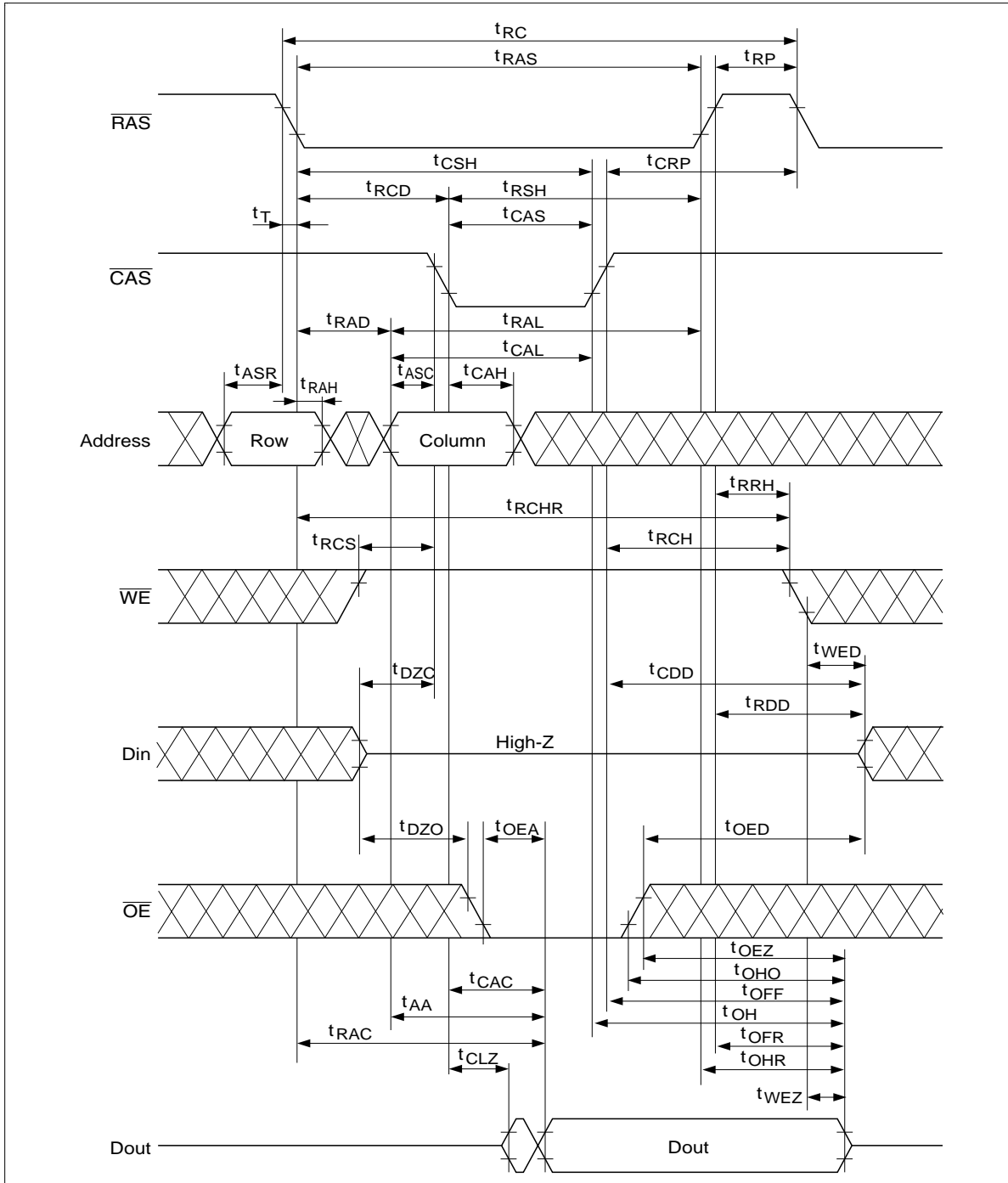

# HB56UW872EJK Series

## Early Write Cycle

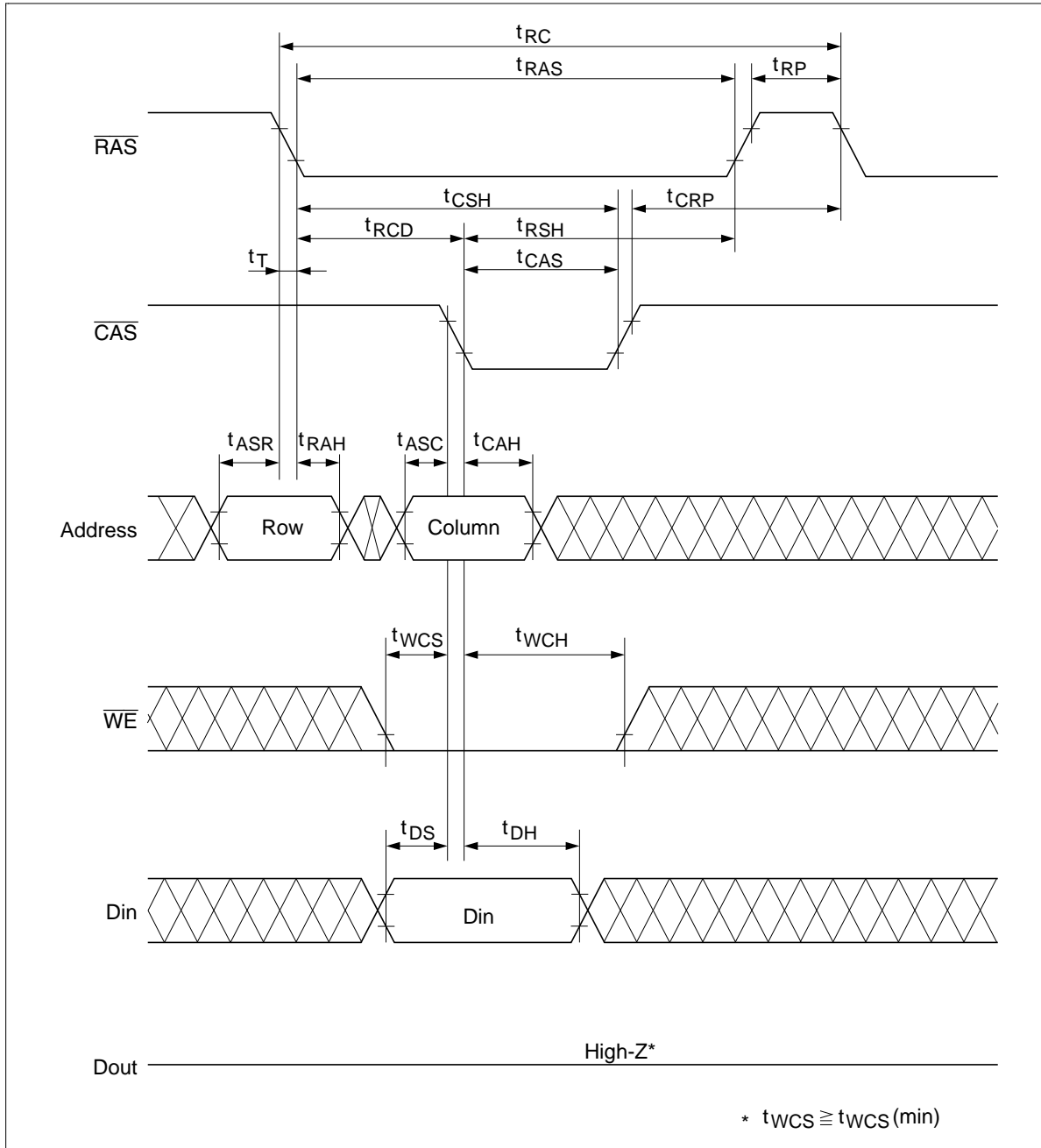

Delayed Write Cycle\*18

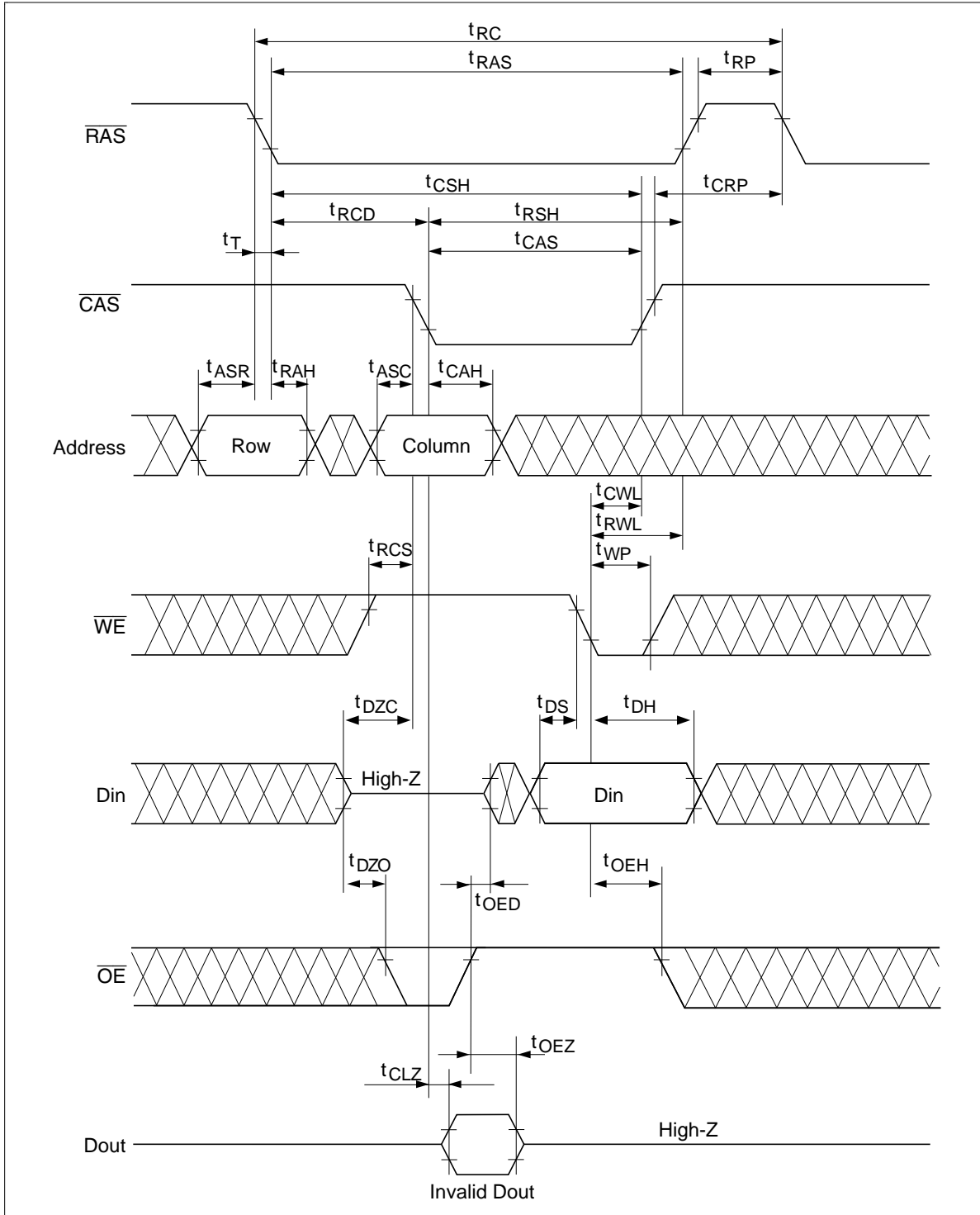

# HB56UW872EJK Series

## Read-Modify-Write Cycle\*18

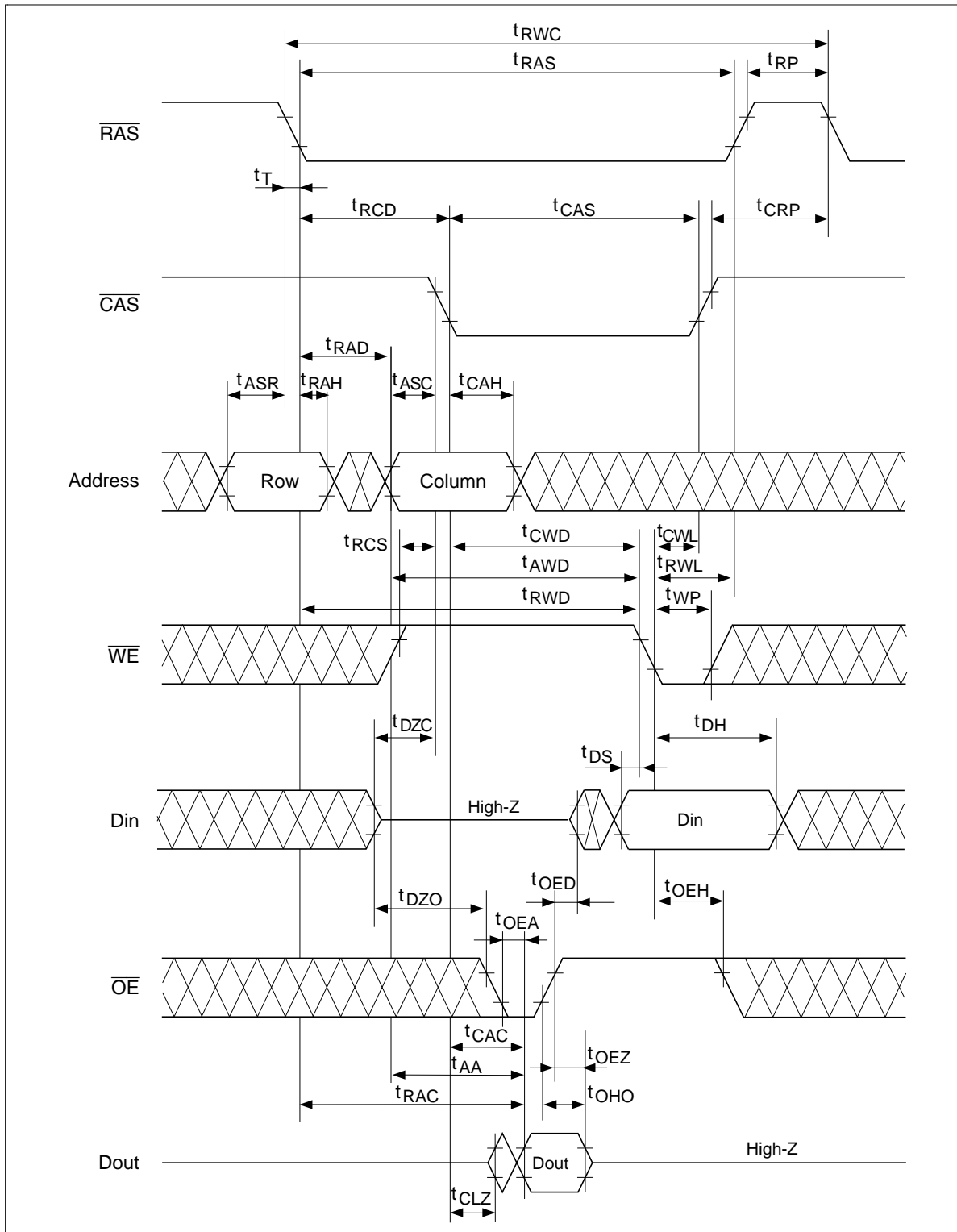



# HB56UW872EJK Series

## $\overline{\text{CAS}}$ -Before- $\overline{\text{RAS}}$ Refresh Cycle

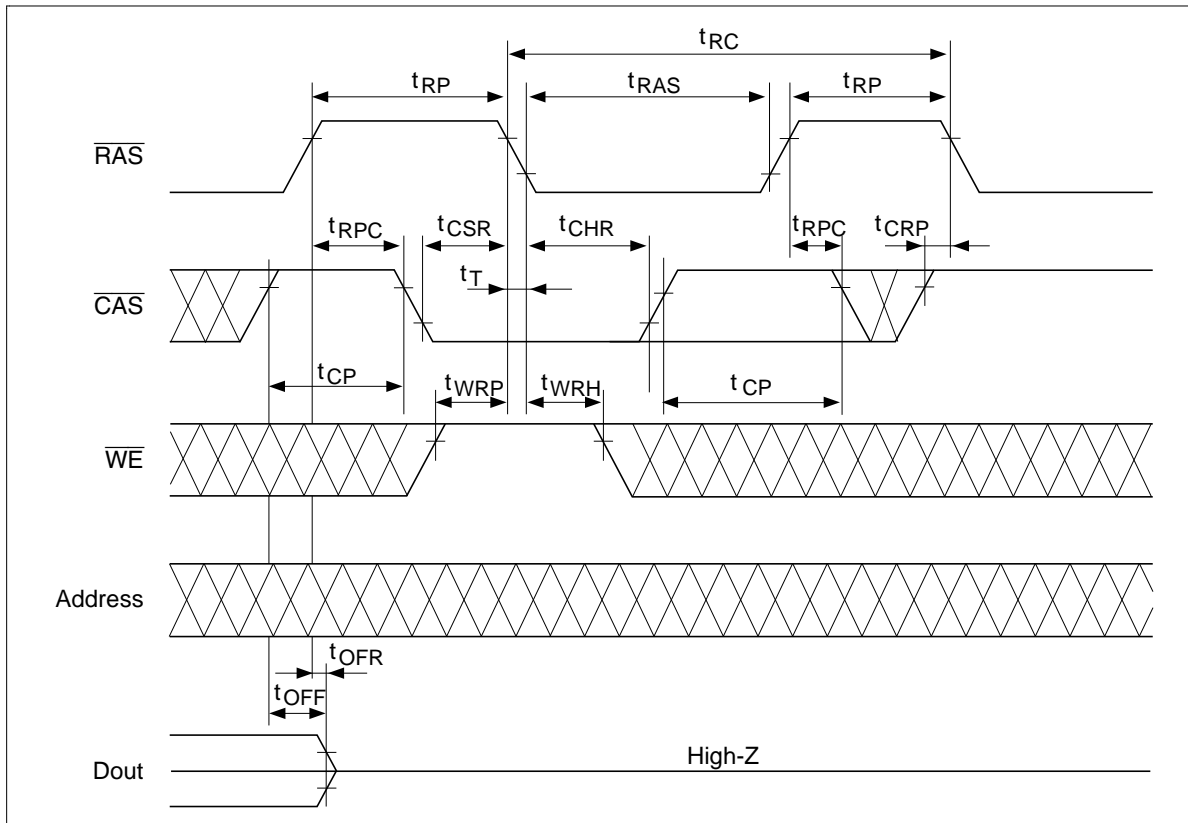



# HB56UW872EJK Series

## EDO Page Mode Early Write Cycle

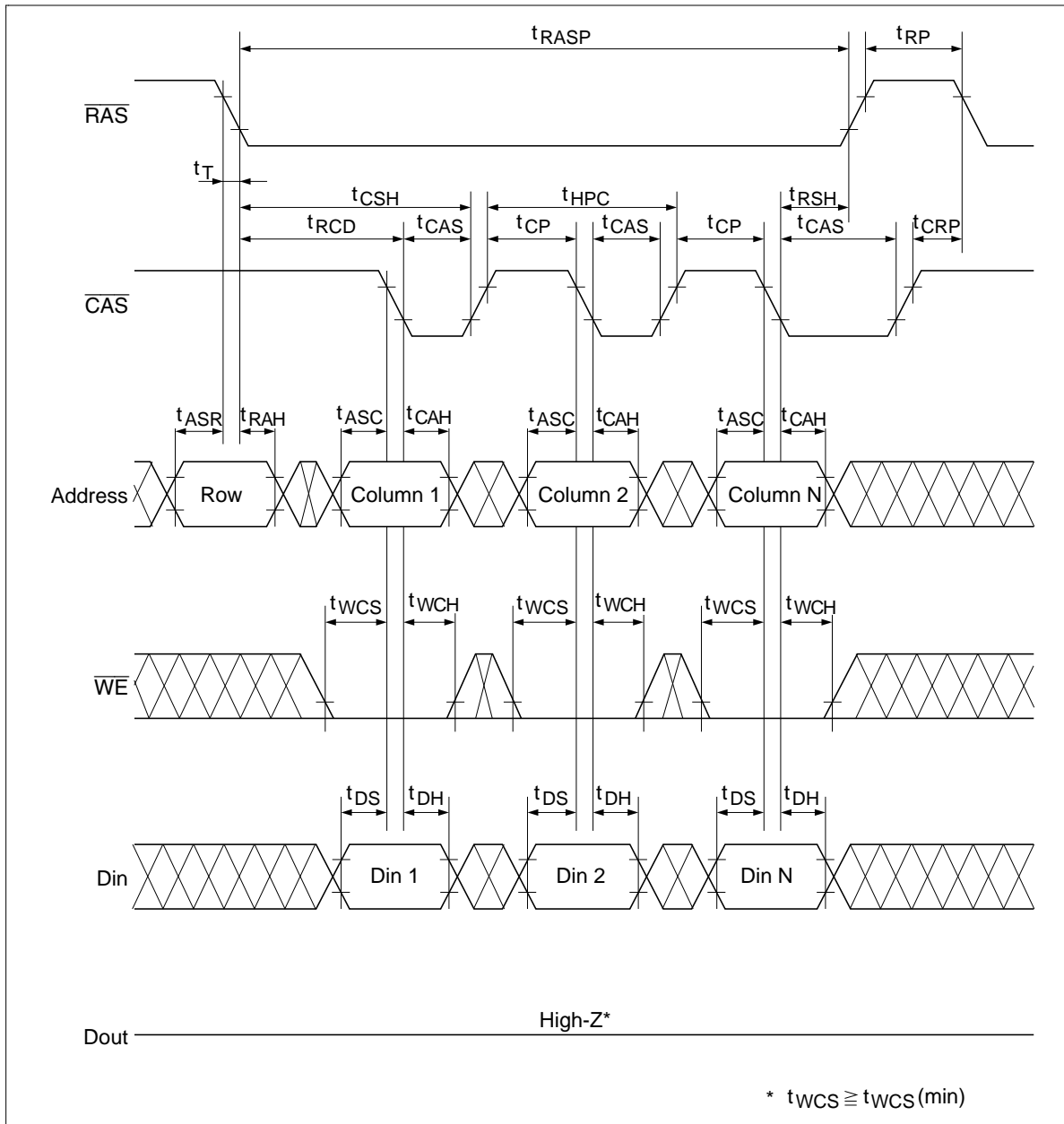

EDO Page Mode Delayed Write Cycle\*18

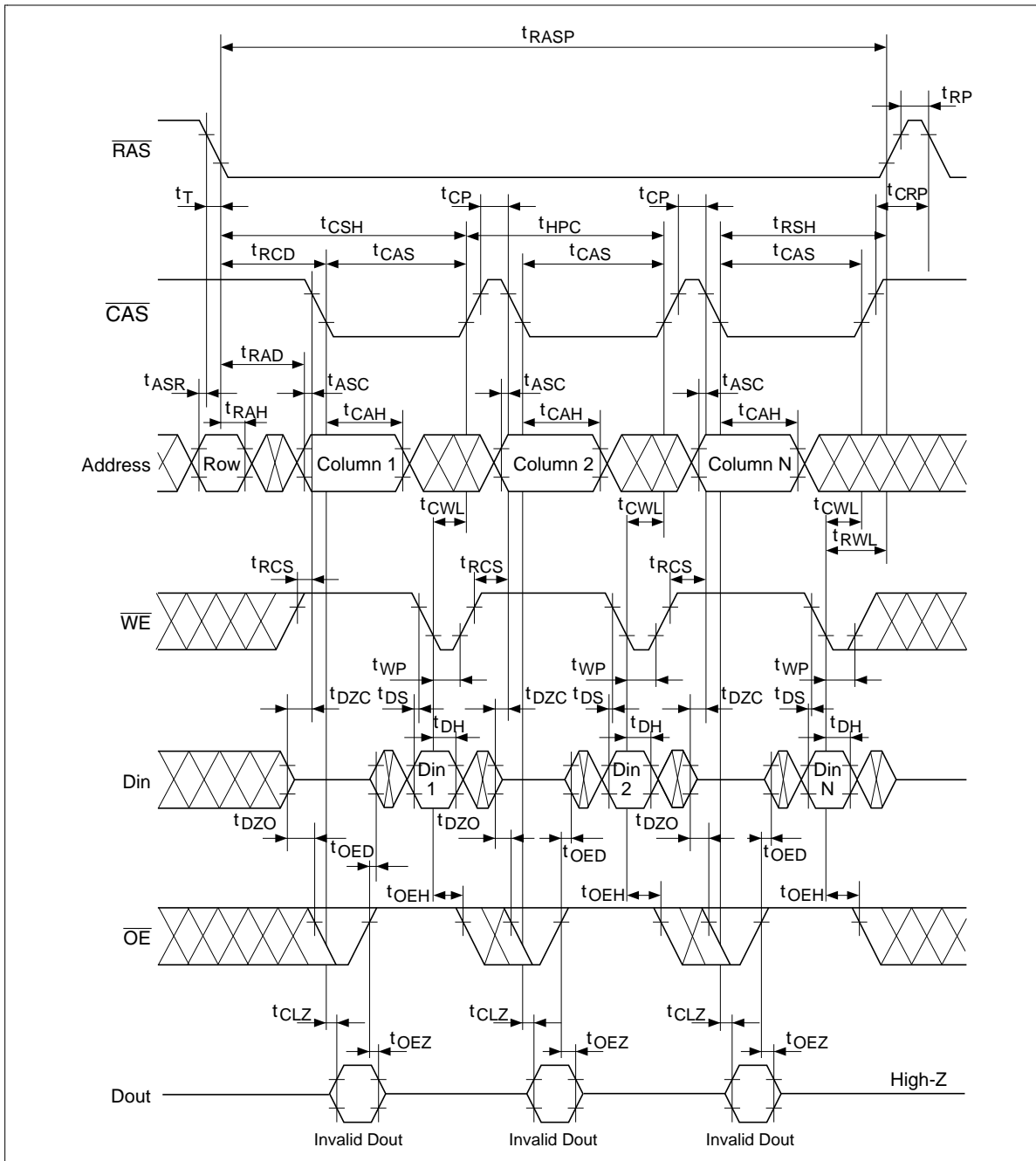

# HB56UW872EJK Series

## EDO Page Mode Read-Modify-Write Cycle\*18

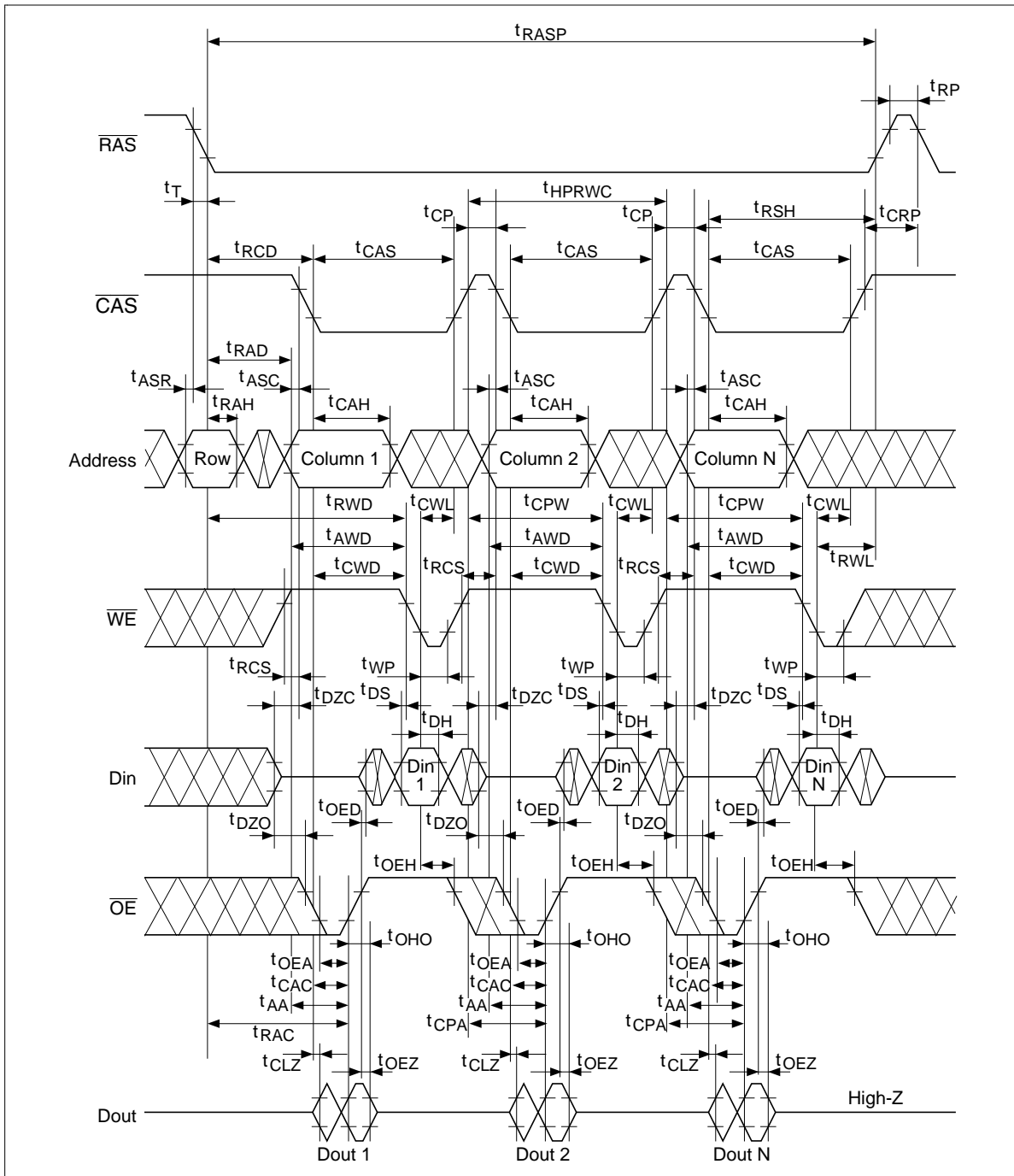

EDO Page Mode Mix Cycle (1)

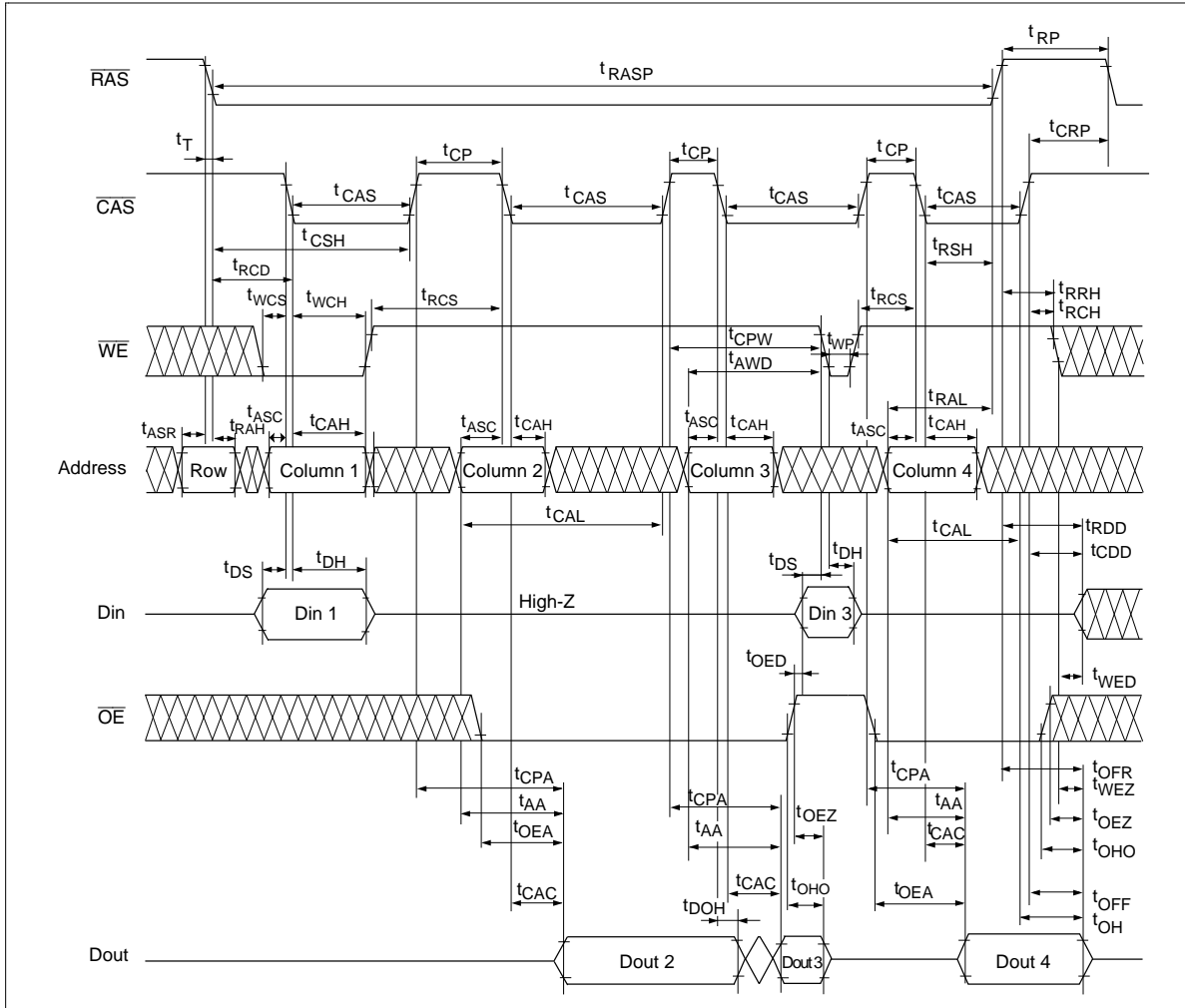

# HB56UW872EJK Series

## EDO Page Mode Mix Cycle (2)

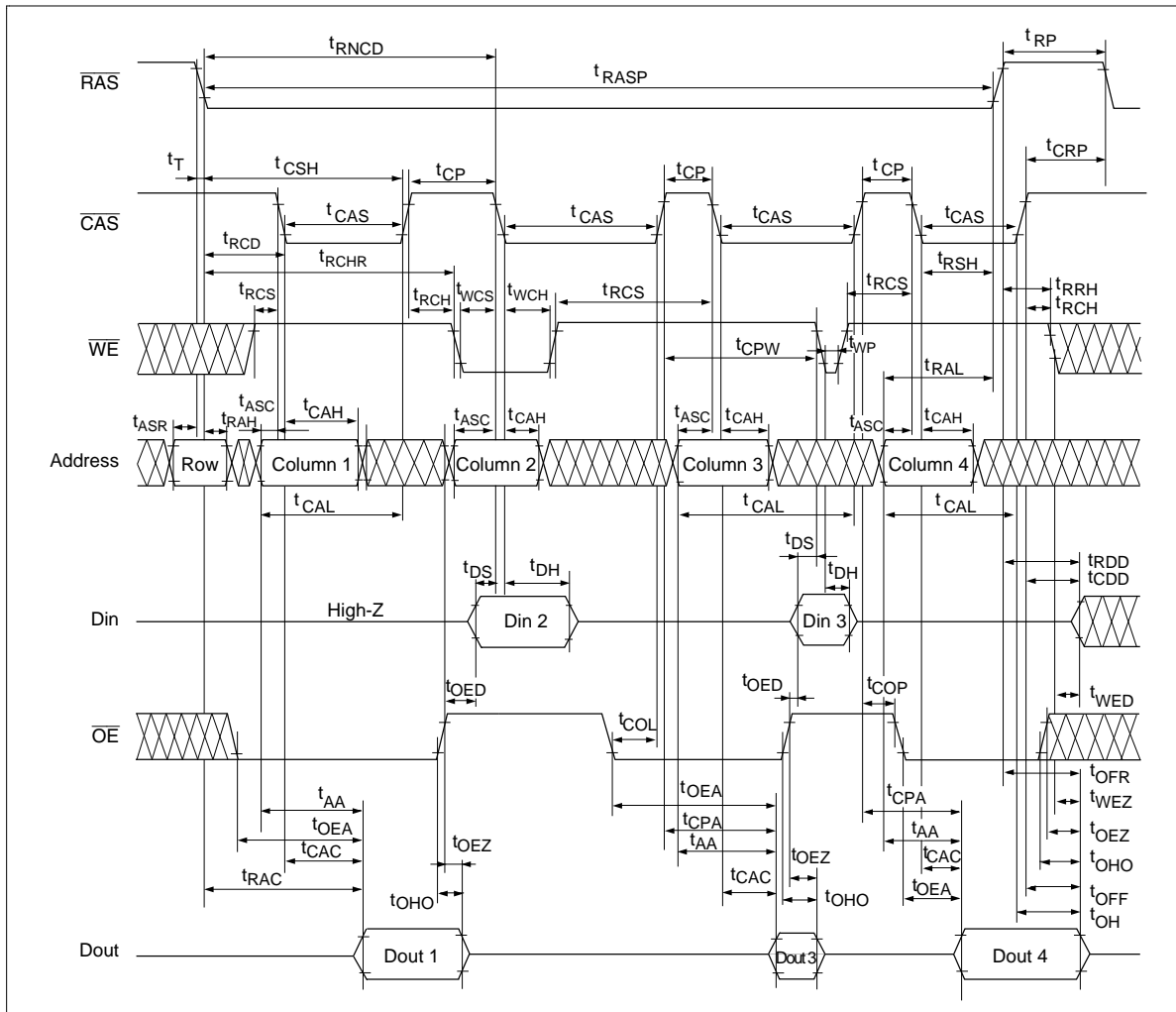

# HB56UW872EJK Series

## Physical Outline

Unit: mm/inch

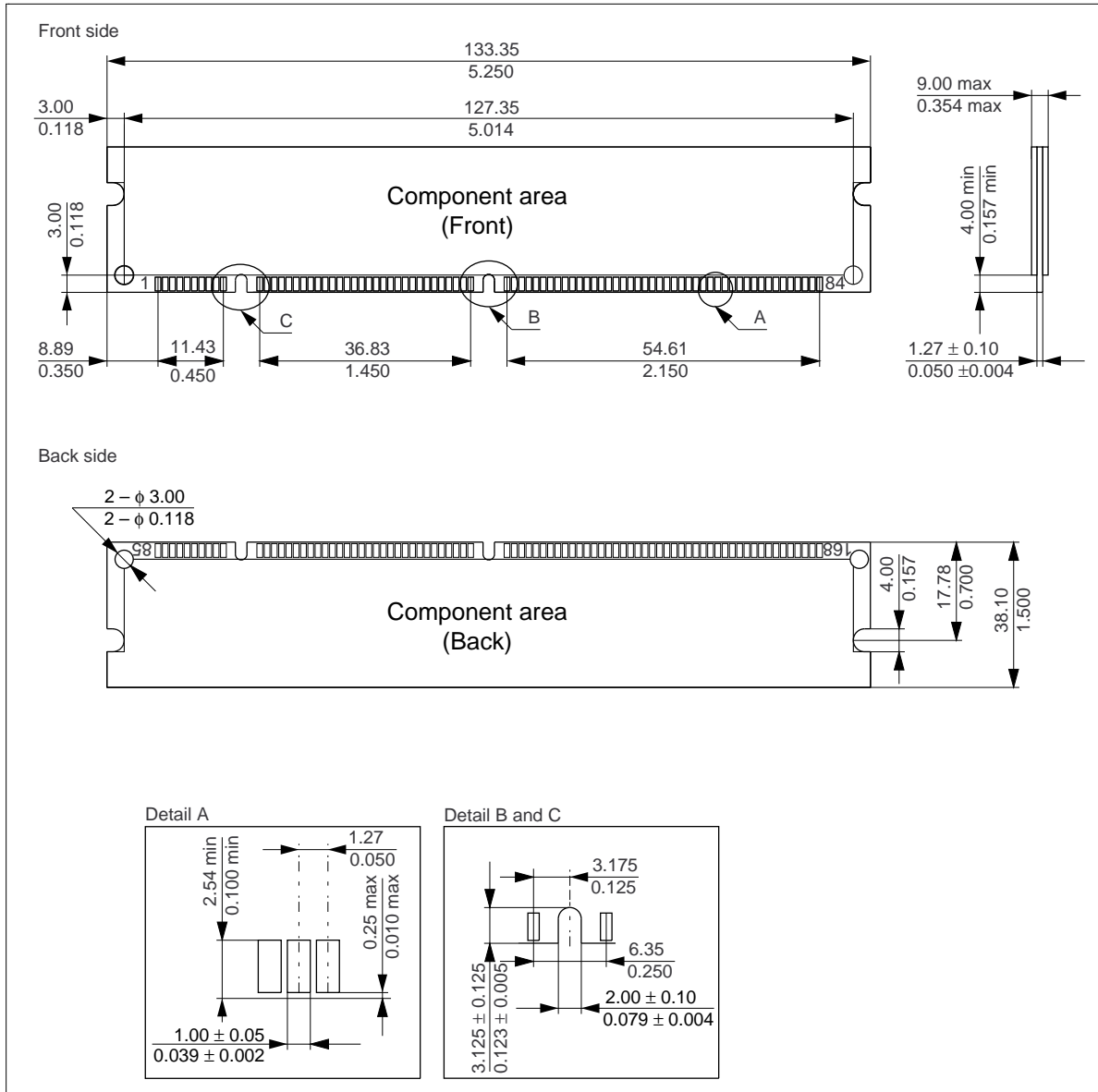

---

## HB56UW872EJK Series

---

When using this document, keep the following in mind:

1. This document may, wholly or partially, be subject to change without notice.
2. All rights are reserved: No one is permitted to reproduce or duplicate, in any form, the whole or part of this document without Hitachi's permission.
3. Hitachi will not be held responsible for any damage to the user that may result from accidents or any other reasons during operation of the user's unit according to this document.
4. Circuitry and other examples described herein are meant merely to indicate the characteristics and performance of Hitachi's semiconductor products. Hitachi assumes no responsibility for any intellectual property claims or other problems that may result from applications based on the examples described herein.
5. No license is granted by implication or otherwise under any patents or other rights of any third party or Hitachi, Ltd.
6. **MEDICAL APPLICATIONS:** Hitachi's products are not authorized for use in **MEDICAL APPLICATIONS** without the written consent of the appropriate officer of Hitachi's sales company. Such use includes, but is not limited to, use in life support systems. Buyers of Hitachi's products are requested to notify the relevant Hitachi sales offices when planning to use the products in **MEDICAL APPLICATIONS**.

---

---

# HITACHI

## Hitachi, Ltd.

Semiconductor & IC Div.  
Nippon Bldg., 2-6-2, Ohte-machi, Chiyoda-ku, Tokyo 100, Japan  
Tel: Tokyo (03) 3270-2111  
Fax: (03) 3270-5109

### For further information write to:

Hitachi America, Ltd.  
Semiconductor & IC Div.  
2000 Sierra Point Parkway  
Brisbane, CA. 94005-1835  
U S A  
Tel: 415-589-8300  
Fax: 415-583-4207

Hitachi Europe GmbH  
Electronic Components Group  
Continental Europe  
Dornacher Straße 3  
D-85622 Feldkirchen  
München  
Tel: 089-9 91 80-0  
Fax: 089-9 29 30 00

Hitachi Europe Ltd.  
Electronic Components Div.  
Northern Europe Headquarters  
Whitebrook Park  
Lower Cookham Road  
Maidenhead  
Berkshire SL6 8YA  
United Kingdom  
Tel: 0628-585000  
Fax: 0628-778322

Hitachi Asia Pte. Ltd.  
16 Collyer Quay #20-00  
Hitachi Tower  
Singapore 0104  
Tel: 535-2100  
Fax: 535-1533

Hitachi Asia (Hong Kong) Ltd.  
Unit 706, North Tower,  
World Finance Centre,  
Harbour City, Canton Road  
Tsim Sha Tsui, Kowloon  
Hong Kong  
Tel: 27359218  
Fax: 27306071

---

**HB56UW872EJK Series**

---

**Revision Record**

---

<b>Rev. Date</b>	<b>Contents of Modification</b>	<b>Drawn by</b>	<b>Approved by</b>
1.0 Jan. 27, 1997	Initial issue		

---