

**SN54S64, SN54S65,  
SN74S64, SN74S65**  
**4-2-3-2 INPUT AND-OR-INVERT GATES**  
SDLS205 – DECEMBER 1983 – REVISED MARCH 1988

- Package Options Include Plastic "Small Outline" Packages, Ceramic Chip Carriers and Flat Packages, and Plastic and Ceramic DIPs

- Dependable Texas Instruments Quality and Reliability

**description**

These devices contain 4-2-3-2 input AND-OR-INVERT gates. They perform the Boolean function  $Y = \overline{ABCD + EF + GHI + JK}$ . The 'S64 has totem-pole outputs and the 'S65 has open-collector outputs.

The SN54S64 and the SN54S65 are characterized for operation over the full military temperature range of  $-55^{\circ}\text{C}$  to  $125^{\circ}\text{C}$ . The SN74S64 and the SN74S65 are characterized for operation from  $0^{\circ}\text{C}$  to  $70^{\circ}\text{C}$ .

**logic symbols†**

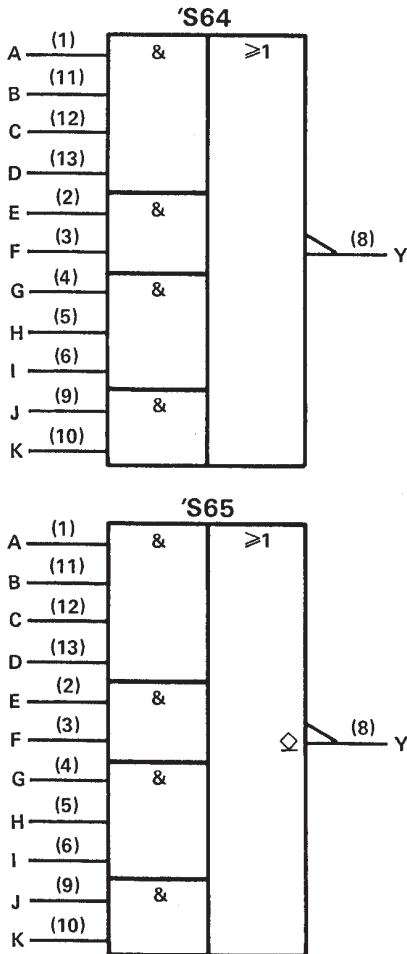

†These symbols are in accordance with ANSI/IEEE Std 91-1984 and IEC Publication 617-12. Pin numbers shown are for D, J, N, and W packages.

SN54S64, SN54S65 . . . J OR W PACKAGE  
SN74S64, SN74S65 . . . D OR N PACKAGE  
(TOP VIEW)

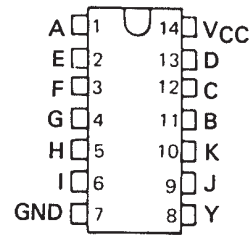

SN54S64, SN54S65 . . . FK PACKAGE  
(TOP VIEW)

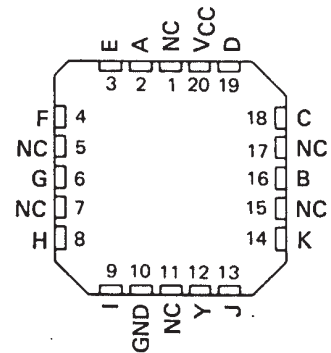

NC - No internal connection

**logic diagram (each device) (positive logic)**

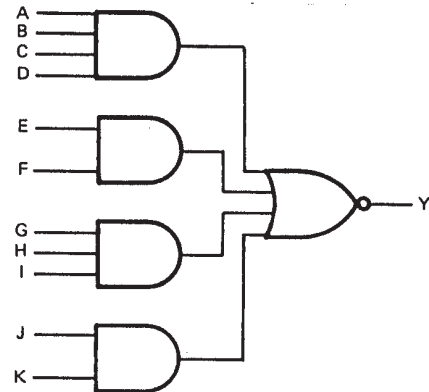

**SN54S64, SN54S65,  
SN74S64, SN74S65**  
**4-2-3-2 INPUT AND-OR-INVERT GATES**

SDLS205 – DECEMBER 1983 – REVISED MARCH 1988

schematics (each gate)

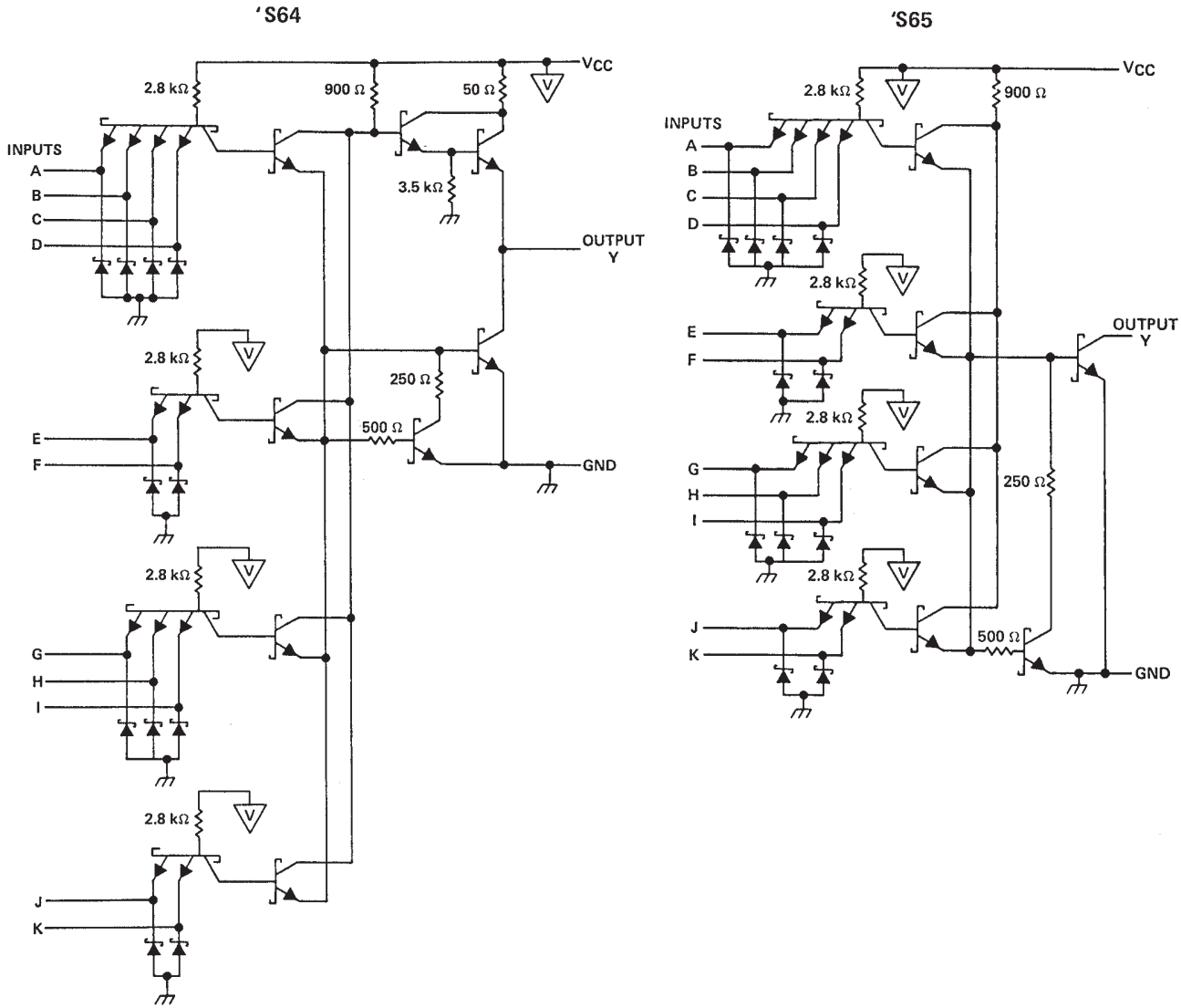

Resistor values shown are nominal and in ohms.

**absolute maximum ratings over operating free-air temperature range (unless otherwise noted)**

Supply voltage, V <sub>CC</sub> (see Note 1)	7 V
Input voltage	5.5 V
Off-state output voltage, 'S65	7 V
Operating free-air temperature range: SN54'	-55°C to 125°C
SN74'	0°C to 70°C
Storage temperature range	-65°C to 150°C



POST OFFICE BOX 655303 • DALLAS, TEXAS 75265

# SN54S64, SN54S65

## 4-2-3-2 INPUT AND-OR-INVERT GATES

SDLS205 – DECEMBER 1983 – REVISED MARCH 1988

### recommended operating conditions

	SN54S64			SN74S64			UNIT
	MIN	NOM	MAX	MIN	NOM	MAX	
V <sub>CC</sub> Supply voltage	4.5	5	5.5	4.75	5	5.25	V
V <sub>IH</sub> High-level input voltage	2			2			V
V <sub>IL</sub> Low-level input voltage			0.8			0.8	V
I <sub>OH</sub> High-level output current			-1			-1	mA
I <sub>OL</sub> Low-level output current			20			20	mA
T <sub>A</sub> Operating free-air temperature	-55		125	0		70	°C

### electrical characteristics over recommended operating free-air temperature range (unless otherwise noted)

PARAMETER	TEST CONDITIONS †	SN54S64		SN74S64		UNIT		
		MIN	TYP ‡	MAX	MIN		TYP ‡	MAX
V <sub>IK</sub>	V <sub>CC</sub> = MIN, I <sub>I</sub> = -18 mA			-1.2		-1.2	V	
V <sub>OH</sub>	V <sub>CC</sub> = MIN, V <sub>IL</sub> = 0.8 V, I <sub>OH</sub> = -1 mA	2.5	3.4		2.7	3.4	V	
V <sub>OL</sub>	V <sub>CC</sub> = MIN, V <sub>IH</sub> = 2 V, I <sub>OL</sub> = 20 mA			0.5		0.5	V	
I <sub>I</sub>	V <sub>CC</sub> = MAX, V <sub>I</sub> = 5.5 V			1		1	mA	
I <sub>IH</sub>	V <sub>CC</sub> = MAX, V <sub>I</sub> = 2.7 V			50		50	μA	
I <sub>IL</sub>	V <sub>CC</sub> = MAX, V <sub>I</sub> = 0.5 V			-2		-2	mA	
I <sub>OS</sub> §	V <sub>CC</sub> = MAX	-40		-100	-40	-100	mA	
I <sub>CC</sub> H	V <sub>CC</sub> = MAX, V <sub>I</sub> = 0		7	12.5		7	12.5	mA
I <sub>CC</sub> L	V <sub>CC</sub> = MAX, V <sub>I</sub> = 4.5 V		8.5	16		8.5	16	mA

† For conditions shown as MIN or MAX, use the appropriate value specified under recommended operating conditions.

‡ All typical values are at V<sub>CC</sub> = 5 V, T<sub>A</sub> = 25°C.

§ Not more than one output should be shorted at a time, and the duration of the short-circuit should not exceed one second.

### switching characteristics, V<sub>CC</sub> = 5 V, T<sub>A</sub> = 25°C (see note 2)

PARAMETER	FROM (INPUT)	TO (OUTPUT)	TEST CONDITIONS		MIN	TYP	MAX	UNIT
t <sub>PLH</sub>	Any	Y	R <sub>L</sub> = 280 Ω,	C <sub>L</sub> = 15 pF		3.5	5.5	ns
t <sub>PHL</sub>						3.5	5.5	ns
t <sub>PLH</sub>			R <sub>L</sub> = 280 Ω,	C <sub>L</sub> = 50 pF		5		ns
t <sub>PHL</sub>						5.5		ns

NOTE 2: Load circuits and voltage waveforms are shown in Section 1.



# SN54S65, SN54S65

## 4-2-3-2 INPUT AND-OR-INVERT GATES

SDLS205 – DECEMBER 1983 – REVISED MARCH 1988

### recommended operating conditions

	SN54S65			SN74S65			UNIT
	MIN	NOM	MAX	MIN	NOM	MAX	
V <sub>CC</sub> Supply voltage	4.5	5	5.5	4.75	5	5.25	V
V <sub>IH</sub> High-level input voltage	2			2			V
V <sub>IL</sub> Low-level input voltage			0.8			0.8	V
V <sub>OH</sub> High-level output voltage			5.5			5.5	V
I <sub>OL</sub> Low-level output current			20			20	mA
T <sub>A</sub> Operating free-air temperature	-55		125	0		70	°C

### electrical characteristics over recommended operating free-air temperature range (unless otherwise noted)

PARAMETER	TEST CONDITIONS†	SN54S65			SN74S65			UNIT
		MIN	TYP‡	MAX	MIN	TYP‡	MAX	
V <sub>IK</sub>	V <sub>CC</sub> = MIN, I <sub>I</sub> = -18 mA			1.2			1.2	V
I <sub>OH</sub>	V <sub>CC</sub> = MIN, V <sub>IL</sub> = 0.8 V, V <sub>OH</sub> = 5.5 V						0.25	mA
	V <sub>CC</sub> = MIN, V <sub>IL</sub> = 0.7 V, V <sub>OH</sub> = 5.5 V			0.25				
V <sub>OL</sub>	V <sub>CC</sub> = MIN, V <sub>IH</sub> = 2 V, I <sub>OL</sub> = 20 mA	0.2	0.4		0.2	0.4		V
I <sub>I</sub>	V <sub>CC</sub> = MAX, V <sub>I</sub> = 5.5 V			1			1	mA
I <sub>IH</sub>	V <sub>CC</sub> = MAX, V <sub>I</sub> = 2.7 V			50			50	μA
I <sub>IL</sub>	V <sub>CC</sub> = MAX, V <sub>I</sub> = 0.5 V			-2			-2	mA
I <sub>CCH</sub>	V <sub>CC</sub> = MAX, V <sub>I</sub> = 0	6	11		6	11		mA
I <sub>CCL</sub>	V <sub>CC</sub> = MAX, V <sub>I</sub> = 4.5 V	8.5	16		8.5	16		mA

†For conditions shown as MIN or MAX, use the appropriate value specified under recommended operating conditions.

‡All typical values are at V<sub>CC</sub> = 5 V, T<sub>A</sub> = 25°C.

### switching characteristics, V<sub>CC</sub> = 5 V, T<sub>A</sub> = 25°C (see note 2)

PARAMETER	FROM (INPUT)	TO (OUTPUT)	TEST CONDITIONS		MIN	TYP	MAX	UNIT
t <sub>PLH</sub>	Any	Y	R <sub>L</sub> = 280 Ω,	C <sub>L</sub> = 15 pF	2	5	7.5	ns
t <sub>PHL</sub>					2	5.5	8.5	ns
t <sub>PLH</sub>			R <sub>L</sub> = 280 Ω,	C <sub>L</sub> = 50 pF	8			ns
t <sub>PHL</sub>					6.5			ns

NOTE 2: Load circuits and voltage waveforms are shown in Section 1.



## **IMPORTANT NOTICE**

Texas Instruments and its subsidiaries (TI) reserve the right to make changes to their products or to discontinue any product or service without notice, and advise customers to obtain the latest version of relevant information to verify, before placing orders, that information being relied on is current and complete. All products are sold subject to the terms and conditions of sale supplied at the time of order acknowledgement, including those pertaining to warranty, patent infringement, and limitation of liability.

TI warrants performance of its semiconductor products to the specifications applicable at the time of sale in accordance with TI's standard warranty. Testing and other quality control techniques are utilized to the extent TI deems necessary to support this warranty. Specific testing of all parameters of each device is not necessarily performed, except those mandated by government requirements.

**CERTAIN APPLICATIONS USING SEMICONDUCTOR PRODUCTS MAY INVOLVE POTENTIAL RISKS OF DEATH, PERSONAL INJURY, OR SEVERE PROPERTY OR ENVIRONMENTAL DAMAGE ("CRITICAL APPLICATIONS"). TI SEMICONDUCTOR PRODUCTS ARE NOT DESIGNED, AUTHORIZED, OR WARRANTED TO BE SUITABLE FOR USE IN LIFE-SUPPORT DEVICES OR SYSTEMS OR OTHER CRITICAL APPLICATIONS. INCLUSION OF TI PRODUCTS IN SUCH APPLICATIONS IS UNDERSTOOD TO BE FULLY AT THE CUSTOMER'S RISK.**

In order to minimize risks associated with the customer's applications, adequate design and operating safeguards must be provided by the customer to minimize inherent or procedural hazards.

TI assumes no liability for applications assistance or customer product design. TI does not warrant or represent that any license, either express or implied, is granted under any patent right, copyright, mask work right, or other intellectual property right of TI covering or relating to any combination, machine, or process in which such semiconductor products or services might be or are used. TI's publication of information regarding any third party's products or services does not constitute TI's approval, warranty or endorsement thereof.

		<b>THE WORLD LEADER IN DSP AND ANALOG</b>	
Products	Development Tools	Applications	
<input type="button" value="GO"/>	<input type="button" value="GO"/>	<input type="button" value="GO"/>	
Search	<input type="checkbox"/> Advanced Search	<input type="checkbox"/> TI Home	<input type="checkbox"/> TI&ME
<input type="button" value="GO"/>	<input type="checkbox"/> Tech Support	<input type="checkbox"/> Comments	<input type="checkbox"/> Site Map
		<input type="checkbox"/> Employment	<input type="checkbox"/> TI Global

**PRODUCT FOLDER** | PRODUCT INFO: [FEATURES](#) | [DESCRIPTION](#) | [DATASHEETS](#) | [PRICING/AVAILABILITY](#) | [APPLICATION NOTES](#) | [RELATED DOCUMENTS](#)

PRODUCT SUPPORT: [TRAINING](#)

## SN54S64, 4-2-3-2 Input AND-OR-invert Gates

DEVICE STATUS: **ACTIVE**

PARAMETER NAME	SN54S64
Voltage Nodes (V)	5
Vcc range (V)	4.5 to 5.5
Input Level	TTL
Output Level	TTL
No. of Gates	1

### FEATURES

[▲ Back to Top](#)

- Package Options Include Plastic "Small Outline" Packages, Ceramic Chip Carriers and Flat Packages, and Plastic and Ceramic DIPs
- Dependable Texas Instruments Quality and Reliability

### DESCRIPTION

[▲ Back to Top](#)

These devices contain 4-2-3-2 input AND-OR-INVERT gates. They perform the Boolean function  $Y = ABCD + EF + GHI + JK$ . The 'S64 has totem-pole outputs and the 'S65 has open-collector outputs.

The SN54S64 and the SN54S65 are characterized for operation over the full military temperature range of  $-55^{\circ}\text{C}$  to  $125^{\circ}\text{C}$ . The SN74S64 and the SN74S65 are characterized for operation from  $0^{\circ}\text{C}$  to  $70^{\circ}\text{C}$ .

### TECHNICAL DOCUMENTS

[▲ Back to Top](#)

To view the following documents, [Acrobat Reader 3.x](#) is required.

To download a document to your hard drive, right-click on the link and choose 'Save'.

**DATASHEET**[▲ Back to Top](#)Full datasheet in Acrobat PDF: [sdls205.pdf](#) (168 KB) (Updated: 03/01/1988)Full datasheet in Zipped PostScript: [sdls205.psz](#) (300 KB)**APPLICATION NOTES**[▲ Back to Top](#)View Application Reports for [Digital Logic](#)

- [Designing With Logic](#) (SDYA009C - Updated: 06/01/1997)
- [Input And Output Characteristics Of Digital Integrated Circuits](#) (SDYA010 - Updated: 10/01/1996)
- [Live Insertion](#) (SDYA012 - Updated: 10/01/1996)

**RELATED DOCUMENTS**[▲ Back to Top](#)

- [Documentation Rules \(SAP\) And Ordering Information](#) (SZZU001B, 4 KB - Updated: 05/06/1999)
- [Logic Selection Guide Second Half 2000](#) (SDYU001N, 5035 KB - Updated: 04/17/2000)
- [MicroStar Junior BGA Design Summary](#) (SCET004, 167 KB - Updated: 07/28/2000)
- [More Power In Less Space - Technical Article](#) (SCAU001A, 850 KB - Updated: 03/01/1996)

**PRICING/AVAILABILITY**[▲ Back to Top](#)

<u>ORDERABLE DEVICE</u>	<u>PACKAGE</u>	<u>PINS</u>	<u>TEMP (°C)</u>	<u>STATUS</u>	<u>BUDGETARY PRICE US\$/UNIT QTY=1000+</u>	<u>PACK QTY</u>	<u>DSCC NUMBER</u>	<u>PRICING/AVAILABILITY</u>
JM38510/07402BCA	<u>J</u>	14	-55 TO 125	ACTIVE	6.86	1		<a href="#">Check stock or order</a>
JM38510/07402BDA	<u>W</u>	14	-55 TO 125	ACTIVE	10.44	150		<a href="#">Check stock or order</a>
SN54S64J	<u>J</u>	14	-55 TO 125	ACTIVE	1.72	500		<a href="#">Check stock or order</a>
SNJ54S64FK	<u>FK</u>	20	-55 TO 125	ACTIVE	7.65	165		<a href="#">Check stock or order</a>
SNJ54S64J	<u>J</u>	14	-55 TO 125	ACTIVE	2.00	1		<a href="#">Check stock or order</a>
SNJ54S64W	<u>W</u>	14	-55 TO 125	ACTIVE	7.15	150		<a href="#">Check stock or order</a>

Table Data Updated on: 11/8/2000