

Film dielectric trimmers

2222 809 05...

FEATURES

- High temperature type
- Housing dimensions:
6 mm × 8 mm × 9 mm
- For a basic grid of 2.54 mm
- Top and bottom adjustment
- Round or hexagonal head
- Vertical version.

APPLICATIONS

- For fine adjustment in professional applications.

DESCRIPTION

The trimmers consist of a polysulphone housing, brass rotor and plated brass stator with PTFE film as the dielectric. The stator plate tags are heat sealed to the housing.

The rotor contact surfaces are plated to ensure a long life and a stable contact even under severe climatic conditions. A coloured dot indicates the maximum capacitance.

Cleaning with solvents is not advised.

Versions are available with either a round head or hexagonal head. Both versions have top adjustment by means of a screwdriver or trimming key and bottom adjustment by means of a key as shown in Fig.4.

For outline drawings and dimensions see Figs 1 and 2.

QUICK REFERENCE DATA

DESCRIPTION	VALUE
C_{min}/C_{max}	0.5/2 to 2/18 pF
Rated voltage (DC)	300 V
Test voltage (DC) for 1 minute	600 V
Maximum contact resistance	5 mΩ
Minimum insulation resistance between stator and rotor	10000 MΩ
Category temperature range	-40 to +125 °C
Climatic category (IEC 60068)	40/125/21
Related specification	IEC 60418-1 and 4
Minimum storage temperature	-55 °C

MECHANICAL DATA

DESCRIPTION	VALUE
Effective angle of rotation	180°
Operating torque: $C_{max} \leq 3.5$ pF $C_{max} > 3.5$ pF	1 to 15 mNm 1 to 20 mNm
Maximum axial thrust	2 N

QUALITY LEVEL

Sampling and data evaluation for quality level in accordance with "MIL-STD-105D" and "IEC 60410":

- <0.15% major defects
- <0.65% minor defects.

Each capacitor is tested for minimum C_{max} and is also subjected to the full test voltage.

Film dielectric trimmers

2222 809 05...

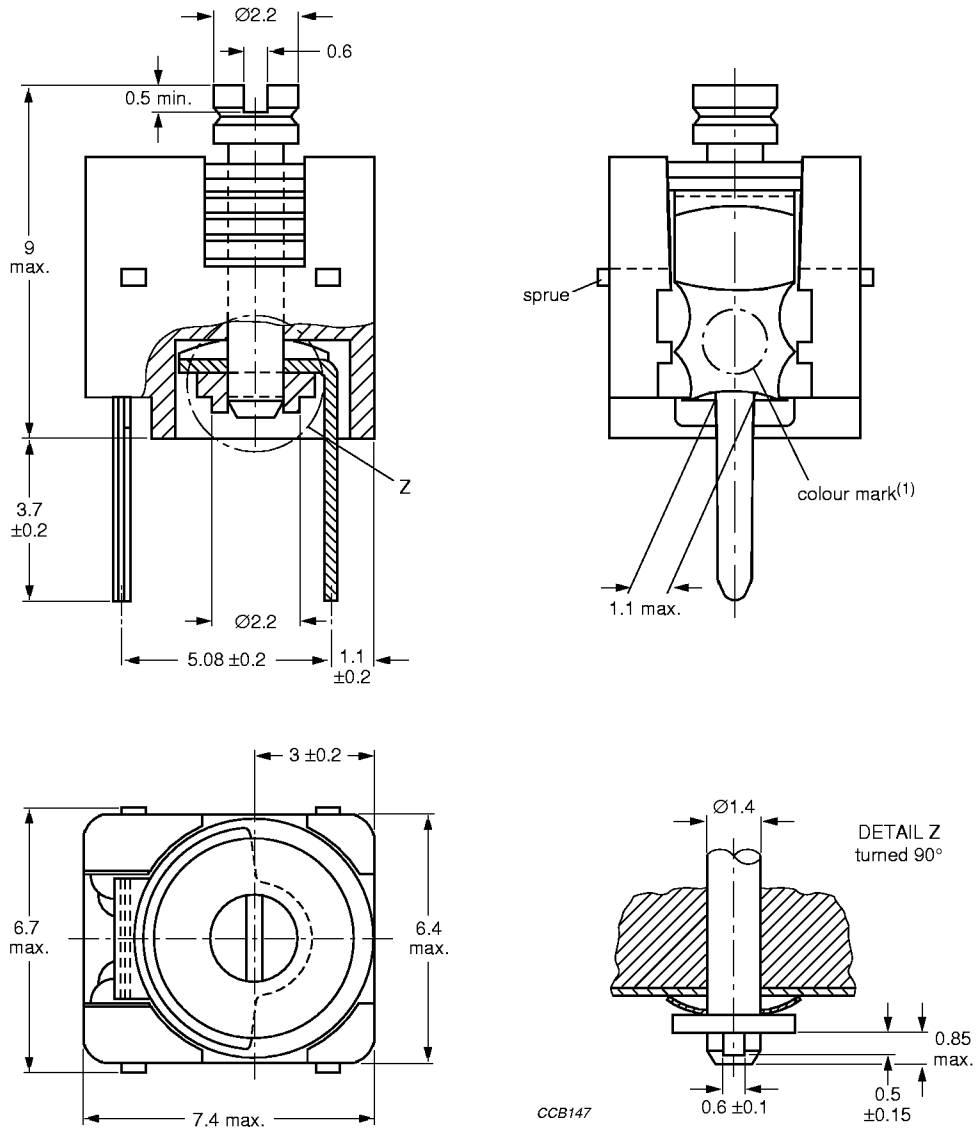

Dimensions in mm.
For hole pattern see Fig.3.
Version with flux guard available; see Table 1.
(1) For colour of dot see Table 2.

Fig.1 Trimmers 2222 809 05... series, with round heads.

Film dielectric trimmers

2222 809 05...

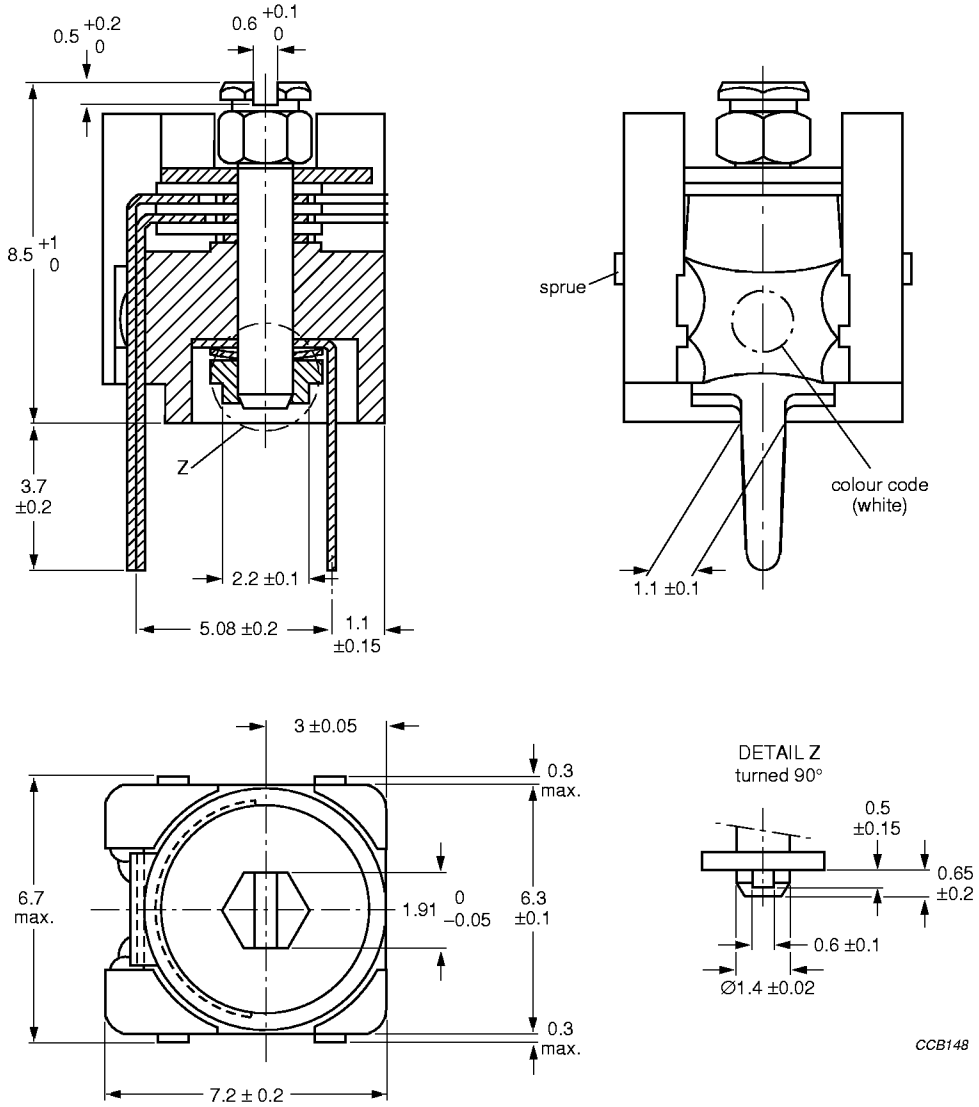

CCB148

Dimensions in mm.
For hole pattern see Fig.3.

Fig.2 Trimmers 2222 809 05... series, with hexagonal heads.

Film dielectric trimmers

2222 809 05...

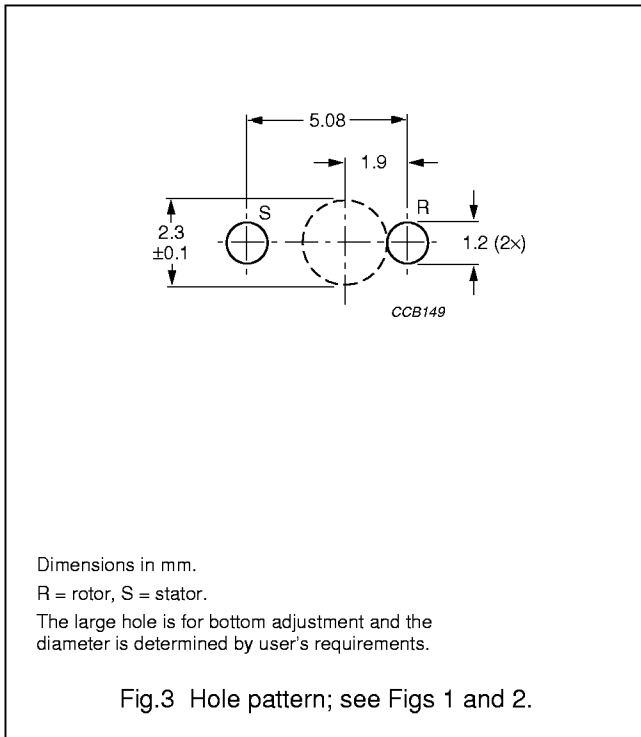

Adjustment

For top adjustment a screwdriver or trimming key can be used; for bottom adjustment a key is required as shown in Fig.4.

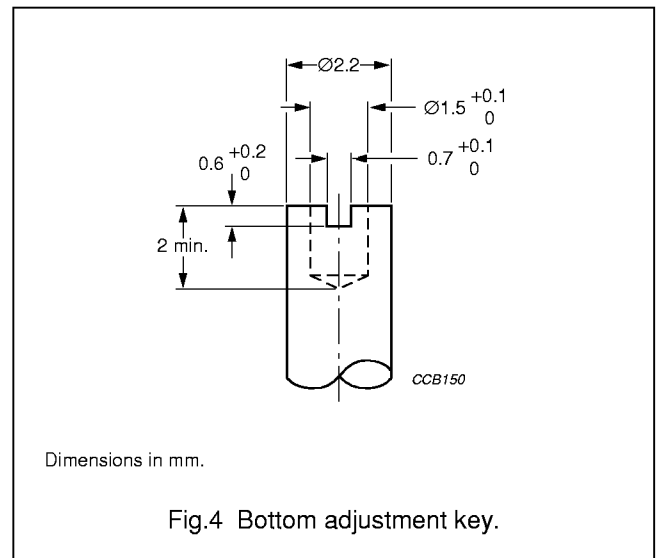

MOUNTING

The trimmer can be mounted on printed-circuit boards with a minimum hole diameter of 2.54 mm. For hole pattern see Fig.3.

PACKAGING

Blister packs of 70 units each. For smallest packaging quantities (SPQ) see Table 2.

Film dielectric trimmers

2222 809 05...

ORDERING INFORMATION

Table 1 Selection chart

C_{\min}/C_{\max} (pF)	CATALOGUE NUMBER 2222 809 05...		
	TOP AND BOTTOM ADJUSTMENT		
	ROUND HEAD	ROUND HEAD AND FLUX GUARD	HEXAGONAL HEAD
0.5/2	011	–	021
1.2/3.5	215	001	225
1.8/10	216	–	226
2/18	217	–	227

ELECTRICAL DATA

Table 2 Electrical characteristics and catalogue numbers

GUARANTEED MAX. $C_{\min}/$ MIN. C_{\max} at 200 kHz (pF)	SHAPE OF HEAD	FIG.	$\tan \delta$ at $C_{\max} \times 10^{-4}$		TEMP. COEFF. ⁽¹⁾ ($10^{-6}/K$)	MIN. f_{res} at C_{\max} (MHz)	COL. OF DOT	SPQ	CATALOGUE NUMBER
			1 MHz	100 MHz					
0.5/2	round	1	≤ 10	≤ 20	-250 ± 350	1200	none	700	2222 809 05011
	hexag.	2						700	2222 809 05021
1.2/3.5	round	1	≤ 10	≤ 20	-250 ± 350	850	orange	700	2222 809 05001
	round	1						700	2222 809 05215
	hexag.	2						700	2222 809 05225
1.8/10	round	1	≤ 10	≤ 20	-250 ± 350	580	white	700	2222 809 05216
	hexag.	2						700	2222 809 05226
2/18	round	1	≤ 10	≤ 25	-250 ± 350	360	red	700	2222 809 05217
	hexag.	2						700	2222 808 05227

Note

1. C: 60% to 80% of C_{\max} ; T_{amb} : from +20 °C to +125 °C.

Film dielectric trimmers

2222 809 05...

TESTS AND REQUIREMENTS

Table 3 Test procedures and requirements

IEC 60418-1 CLAUSE	IEC 60068 TEST METHOD	TEST	PROCEDURE	REQUIREMENTS
4.2		method of mounting	method A	
14		capacitance drift	after TC measurement	$\Delta C/C: \leq 2.5\%$; 4% for 2 pF
19		thrust	axial thrust of 2 N	$\Delta C/C: \leq 0.3\%$
21		robustness of terminations:		
21.1	Ua	tensile	1 N	no damage
21.2	Ub	bending	1 cycle	no damage
22	Na	rapid change of temperature	1 cycle; 0.5 hours at lower and 0.5 hours at upper category temperature	$\Delta C/C: \leq 2.5\%$
23	T	soldering:		
	Ta	solderability	solder bath immersion 3 mm; 235 °C; 2 s	good wetting no mechanical damage
	Tb	resistance to heat	solder bath: 260 °C; 10 s	no mechanical damage
24	Eb	impact bump	4000 \pm 10 bumps; 40 g; 6 ms	$\Delta C/C: \leq 0.6\%$; no mechanical damage
25	Fc	vibration	frequency 10 to 55 Hz; amplitude 0.35 mm; 1.5 hours	$\Delta C/C: \leq 0.2\%$; no mechanical damage
26		climatic sequence:		
26.1	B	dry heat	16 hours at upper category temperature	$\Delta C/C: \leq 2.5\%$ $\tan \delta: \leq 10 \times 10^{-4}$ for $C_{max} < 18$ pF; $\tan \delta: \leq 40 \times 10^{-4}$ for $C_{max} \geq 18$ pF $R_{ins}: \geq 10\,000$ M Ω ; rotor contact R: ≤ 5 m Ω
26.2	D	damp heat accelerated, first cycle	1 cycle; 24 hours; +40 °C; 95 to 100% RH	voltage proof: 600 V for 1 minute
26.3	Aa	cold	16 hours; -40 °C	visual examination: no mechanical damage
26.5		damp heat accelerated, remaining cycles	1 cycle; 24 hours; +40 °C; 95 to 100% RH	operating torque: 1 to 20 mNm

Film dielectric trimmers

2222 809 05...

IEC 60418-1 CLAUSE	IEC 60068 TEST METHOD	TEST	PROCEDURE	REQUIREMENTS
27	Ca	damp heat steady state	21 days; +40 °C; 90 to 95% RH	$\Delta C/C: \leq 2.5\%$ $\tan \delta: \leq 10 \times 10^{-4}$ for $C_{\max} < 18$ pF; $\tan \delta: \leq 25 \times 10^{-4}$ for $C_{\max} \geq 18$ pF $R_{\text{ins}}: \geq 10\,000$ M Ω ; rotor contact R: ≤ 5 m Ω voltage proof: 600 V for 1 minute visual examination: no mechanical damage operating torque: 1 to 20 mNm
29		mechanical endurance	25 cycles	$\Delta C/C: \leq 0.3\%; \leq 2.5\%$ for 2 pF $\Delta C/C$ after axial thrust: $\leq 0.3\%$; rotor contact R: ≤ 5 m Ω voltage proof: 600 V for 1 minute visual examination: no mechanical damage operating torque: 1 to 20 mNm