

Applications

- Wideband Wireless Systems
- Satellite Signal Transmission Via Fiber
- Narrow Transmitter Housings
- Networks with Limited Fiber
- Architectures Using Separate Optical Wavelengths to Carry Targeted Services

Features

- Standard ITU Grid Wavelengths
- Advanced Analog Chip Design
- Reduced Equipment Requirements in the Hub
- OC-48 Pin Out
- Telcordia Technologies™ 468 Compliant
- Wide Temperature Range – Stable Even in Harsh Environments

The 1754W laser module is a Dense Wavelength Division Multiplexing (DWDM) laser for analog wireless applications. It features a distributed-feedback chip that has been designed specifically for radio frequency (RF) applications. The 1754W laser module has a wide temperature range for reliable performance in harsh node environments and narrow transmitter designs. It also features low adiabatic chirp to maximize signal quality in short and long lengths of fiber. The laser's excellent inherent linearity minimizes degradation of the broadcast signals caused by quadrature amplitude modulated (QAM) channels.

The 1754W is available in a wide range of standard ITU grid wavelengths.

Performance Highlights

	Min	Typical	Max	Units
Available wavelengths	1527.99	-	1562.23	nm
Optical Output Power	8	-	14	mW
Temperature Range	-40	-	+85	°C
Frequency Range	5	-	2700	MHz
Input Third Order Intercept	32	-	-	dBm
1 dB Compression Point	18	-	-	dBm
Adiabatic Chirp (measured at 500 MHz)	40	-	100	MHz/mA

Absolute Maximum Ratings

Stresses in excess of the absolute maximum ratings can cause permanent damage to the device. These are absolute stress ratings only. Functional operation of the device is not implied at these or any other conditions in excess of those given in the operational sections of the data sheet. Exposure to absolute maximum ratings for extended periods can adversely affect device reliability.

Parameter	Symbol	Condition	Min	Max	Units
Operating Case Temperature	T_C	continuous	-40	+85	°C
Storage Temperature	T_{STG}	-	-40	+85	°C
Laser Forward dc Current	-	-	-	150	mA
Reverse Voltage Photodiode	V_{RPD}	-	-	10	V
Laser Reverse Voltage, dc	-	-	-	2	V
ESD	-	HBM: R = 1500 Ohm, C = 100 pF	-500	500	V
TEC Current	I_{TEC}	continuous	-1.9	1.9	A

Electrical/Optical Characteristics

Laser Temperature (TL) = 25°C, $I_F = I_{OP}$, Beginning of Life (BOL)

Parameter	Symbol	Condition	Min	Typ	Max	Unit
Wavelength	-	ITU Grid	1527.99	-	1562.23	nm
Optical Output Power	-		8	-	14	mW
Slope Efficiency	η		.14	-	-	W/A
Optical Isolation	ISO		30	-	-	dB
Sidemode Suppression Ratio	SMSR		30	-	-	dB
Relative Intensity Noise	RIN	$I_F = I_{TH} + 70\text{mA}$, $T = 25^\circ\text{C}$ 5MHz - 2700MHz	-	-	-155	dB/Hz
Threshold Current	I_{TH}		-	-	30	mA
Operating Current	I_{OP}		-	-	120	mA
Monitor PD Responsivity	r_{PD}	$V_{RM} = 5\text{V}$	10	-	200	$\mu\text{A/mW}$
Thermistor Resistance	R_{TH}	$T_{OP} = 25^\circ\text{C}$	9.5	10	10.5	K Ω
Thermistor Temp. Coefficient	TC_{TH}	$T_{OP} = 25^\circ\text{C}$	-	-4.4	-	%/°C
TEC Current	I_{TEC}	$-40 < T_C < +85^\circ\text{C}$; $I_F = 100\text{mA}$	-1.5	-	1.6	A
Fiber Length	-	May include splice	1.0	1.5	-	m
Fiber Buffer	-	-	-	900	-	μm
Fiber Core / Cladding	-	-	-	9/125	-	μm

RF Characteristic

Laser Temperature (TL) = 25°C, I_F=I_{OP}, Beginning of Life (BOL)

Parameter	Symbol	Condition	Min	Typ	Max	Units
Frequency Range		F	-	5	-	2700 MHz
Frequency Response		S21	Any 500 MHz 5-2700 MHz	-	2 4	- dB, p-p dB, p-p
Input Third Order Intercept		IIP3	-	32	-	-
1 dB Compression point		-	-	18	-	-
Nominal Input Impedance		Z _{IN}	-	-	25	-
Return Loss – Tested w/ resistive match 50Ω to 25Ω pad		S11	-	16	-	-

In order to prevent reflection-induced distortion, the laser must be connected to an optical cable having a return loss of at least 55 dB for discrete reflections and 30 dB for distributed reflection

Electrical Schematics

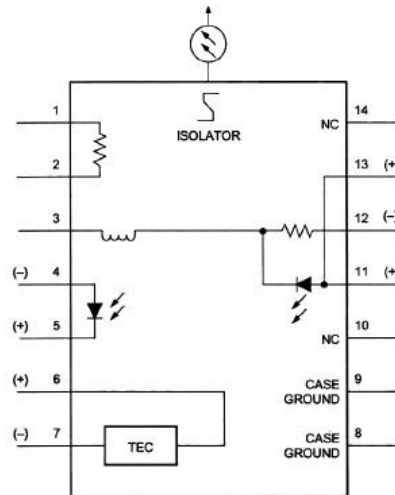

Figure 1. 1754W Laser Schematic

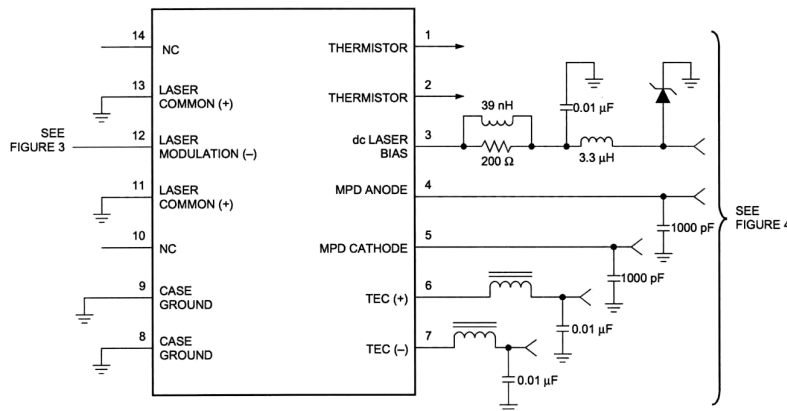
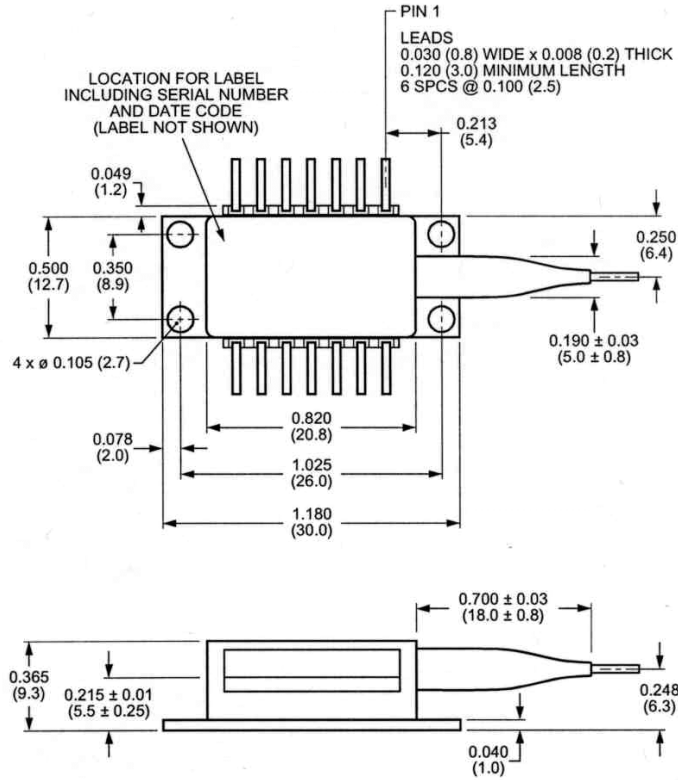
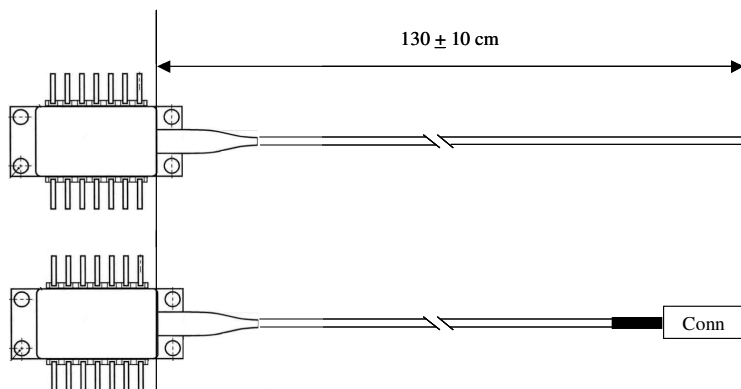

Figure 2. 1754W Circuit Schematic

Outline Diagram (Dimensions are in inches and millimeters)



Fiber type: 0.9 mm O.D. jacketed single mode 9/125 mm (SMF-28)
 Fiber length: 130 cm + 10 cm, measured as shown below
 Nominal pin lead length: 0.2 inch (from external package wall)



Pin Definitions

Pin	Description
1	Thermistor
2	Thermistor
3	Dc Laser Bias (-)
4	MPD Anode (-)
5	MPD Cathode (+)
6	Thermal Electric Cooler (+)
7	Thermal Electric Cooler (-)
8	Case Ground
9	Case Ground
10	NC
11	Laser Common (+)
12	Laser Modulation (-)
13	Laser Common (+)
14	NC

Laser Safety

This product meets the appropriate standard in Title 21 of the Code of Federal Regulations (CFR). FDA/CDRH Class 1 laser product. This device has been classified with the FDA/CDRH under accession number 0220309.

All Versions of this laser are Class 1 laser product, tested according to IEC 60825-1:2007/EN 60825-1:2007

Single-mode fiber pigtail with SC/APC connectors (standard).

Wavelength = 1.5 μm .

Maximum power = 30 mW.

Because of size constraints, laser safety labeling (including an FDA class 1 label) is not affixed to the module, but attached to the outside of the shipping carton.

Product is not shipped with power supply.

Caution: Use of controls, adjustments and procedures other than those specified herein may result in hazardous laser radiation exposure.

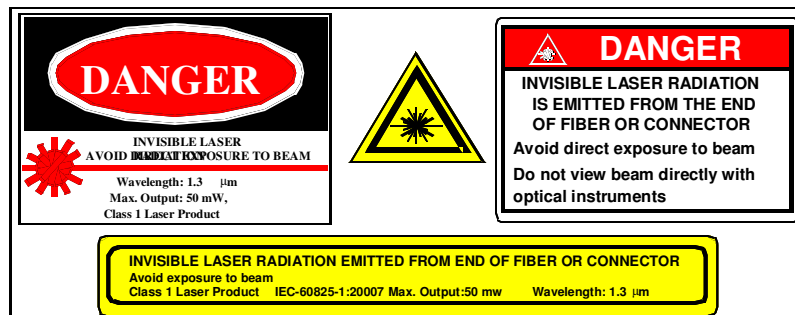

Ordering Code Definitions

1754W – 19 - WW – SC

