



ICS85210-21

LOW SKEW, DUAL, 1-TO-5 DIFFERENTIAL-TO-HSTL FANOUT BUFFER

GENERAL DESCRIPTION

The ICS85210-21 is a low skew, high performance dual 1-to-5 Differential-to-HSTL Fanout Buffer. The CLKx, nCLKx pairs can accept most standard differential input levels. The ICS85210-21 is characterized to operate from a 3.3V power supply. Guaranteed output and part-to-part skew characteristics make the ICS85210-21 ideal for those clock distribution applications demanding well defined performance and repeatability.

FEATURES

- Dual 1-to-5 HSTL bank outputs
- 2 selectable differential clock input pairs
- CLKx, nCLKx pairs can accept the following differential input levels: LVPECL, LVDS, HSTL, SSTL, HCSL
- Maximum output frequency: 650MHz
- Translates any single ended input signal to 3.3V HSTL levels with resistor bias on nCLKx inputs
- Output skew: 50ps (maximum)
- Part-to-part skew: 350ps (maximum)
- Propagation delay: 2ns (maximum)
- 3.3V core, 1.8V output operating supply
- 0°C to 70°C ambient operating temperature
- Industrial temperature information available upon request

BLOCK DIAGRAM

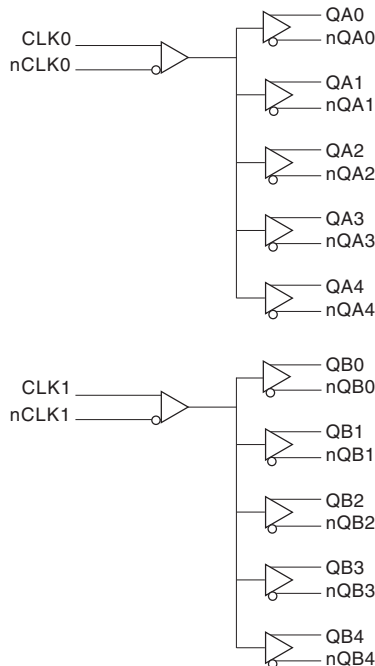

PIN ASSIGNMENT

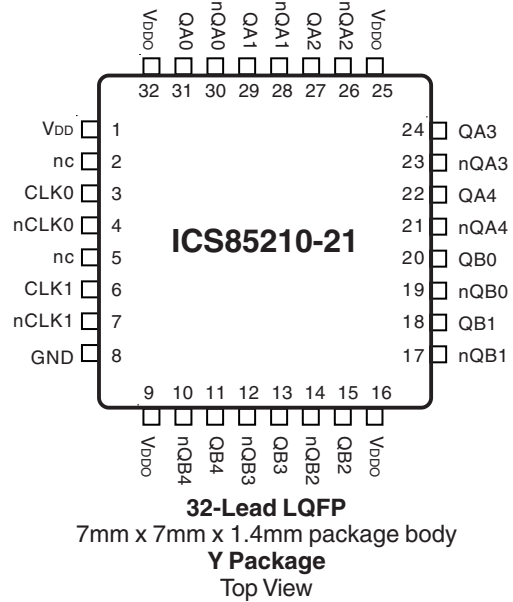



ICS85210-21

LOW SKEW, DUAL, 1-TO-5 DIFFERENTIAL-TO-HSTL FANOUT BUFFER

TABLE 1. PIN DESCRIPTIONS

Number	Name	Type		Description
1	V _{DD}	Power		Core supply pin.
2, 5	nc	Unused		No connect.
3	CLK0	Input	Pulldown	Non-inverting differential clock input.
4	nCLK0	Input	Pullup	Inverting differential clock input.
6	CLK1	Input	Pulldown	Non-inverting differential clock input.
7	nCLK1	Input	Pullup	Inverting differential clock input.
8	GND	Power		Power supply ground.
9, 16, 25, 32	V _{DDO}	Power		Output supply pins.
10, 11	nQB4, QB4	Output		Differential output pair. HSTL interface levels.
12, 13	nQB3, QB3	Output		Differential output pair. HSTL interface levels.
14, 15	nQB2, QB2	Output		Differential output pair. HSTL interface levels.
17, 18	nQB1, QB1	Output		Differential output pair. HSTL interface levels.
19, 20	nQB0, QB0	Output		Differential output pair. HSTL interface levels.
21, 22	nQA4, QA4	Output		Differential output pair. HSTL interface levels.
23, 24	nQA3, QA3	Output		Differential output pair. HSTL interface levels.
26, 27	nQA2, QA2	Output		Differential output pair. HSTL interface levels.
28, 29	nQA1, QA1	Output		Differential output pair. HSTL interface levels.
30, 31	nQA0, QA0	Output		Differential output pair. HSTL interface levels.

NOTE: *Pullup* and *Pulldown* refer to internal input resistors. See Table 2, Pin Characteristics, for typical values.

TABLE 2. PIN CHARACTERISTICS

Symbol	Parameter	Test Conditions	Minimum	Typical	Maximum	Units
C _{IN}	Input Capacitance			4		pF
R _{PULLUP}	Input Pullup Resistor			51		KΩ
R _{PULLDOWN}	Input Pulldown Resistor			51		KΩ



ICS85210-21

LOW SKEW, DUAL, 1-TO-5 DIFFERENTIAL-TO-HSTL FANOUT BUFFER

ABSOLUTE MAXIMUM RATINGS

Supply Voltage, V_{DD}	4.6V
Inputs, V_i	-0.5V to $V_{DD} + 0.5V$
Outputs, I_o	
Continuous Current	50mA
Surge Current	100mA
Package Thermal Impedance, θ_{JA}	47.9°C/W (0 lfpm)
Storage Temperature, T_{STG}	-65°C to 150°C

NOTE: Stresses beyond those listed under Absolute Maximum Ratings may cause permanent damage to the device. These ratings are stress specifications only. Functional operation of product at these conditions or any conditions beyond those listed in the *DC Characteristics* or *AC Characteristics* is not implied. Exposure to absolute maximum rating conditions for extended periods may affect product reliability.

TABLE 3A. POWER SUPPLY DC CHARACTERISTICS, $V_{DD} = 3.3V \pm 5\%$, $V_{DDO} = 1.8V \pm 0.2V$, $T_A = 0^\circ C$ TO $70^\circ C$

Symbol	Parameter	Test Conditions	Minimum	Typical	Maximum	Units
V_{DD}	Input Power Supply Voltage		3.135	3.3	3.465	V
V_{DDO}	Output Power Supply Voltage		1.6	1.8	2.0	V
I_{DD}	Power Supply Current				120	mA
I_{DDO}	Output Supply Current	No Load		0		mA

TABLE 3B. DIFFERENTIAL DC CHARACTERISTICS, $V_{DD} = 3.3V \pm 5\%$, $V_{DDO} = 1.8V \pm 0.2V$, $T_A = 0^\circ C$ TO $70^\circ C$

Symbol	Parameter	Test Conditions	Minimum	Typical	Maximum	Units
I_{IH}	Input High Current	nCLK0, nCLK1	$V_{DD} = V_{IN} = 3.465V$		5	μA
		CLK0, CLK1	$V_{DD} = V_{IN} = 3.465V$		150	μA
I_{IL}	Input Low Current	nCLK0, nCLK1	$V_{DD} = 3.465V, V_{IN} = 0V$	-150		μA
		CLK0, CLK1	$V_{DD} = 3.465V, V_{IN} = 0V$	-5		μA
V_{PP}	Peak-to-Peak Input Voltage		0.15		1.3	V
V_{CMR}	Common Mode Input Voltage; NOTE 1, 2		0.5		$V_{DD} - 0.85$	V

NOTE 1: For single ended applications the maximum input voltage for CLKx and nCLKx is $V_{DD} + 0.3V$.

NOTE 2: Common mode voltage is defined as V_{IH} .

TABLE 3C. HSTL DC CHARACTERISTICS, $V_{DD} = 3.3V \pm 5\%$, $V_{DDO} = 1.8V \pm 0.2V$, $T_A = 0^\circ C$ TO $70^\circ C$

Symbol	Parameter	Test Conditions	Minimum	Typical	Maximum	Units
V_{OH}	Output High Voltage; NOTE 1		1		1.4	V
V_{OL}	Output Low Voltage; NOTE 1		0		0.4	V
V_{OX}	Output Crossover Voltage		$40\% \times (V_{OH} - V_{OL}) + V_{OL}$		$60\% \times (V_{OH} - V_{OL}) + V_{OL}$	V
V_{SWING}	Peak-to-Peak Output Voltage Swing		0.6		1.1	V

NOTE 1: Outputs terminated with 50Ω to ground.



ICS85210-21

LOW SKEW, DUAL, 1-TO-5 DIFFERENTIAL-TO-HSTL FANOUT BUFFER

TABLE 4. AC CHARACTERISTICS, $V_{DD} = 3.3V \pm 5\%$, $V_{DDO} = 1.8V \pm 0.2V$, $T_A = 0^\circ C$ TO $70^\circ C$

Symbol	Parameter	Test Conditions	Minimum	Typical	Maximum	Units
f_{MAX}	Output Frequency				650	MHz
t_{PD}	Propagation Delay; NOTE 1	$f \leq 650MHz$	1.5		2	ns
$t_{sk(o)}$	Output Skew; NOTE 2, 4				50	ps
$t_{sk(pp)}$	Part-to-Part Skew; NOTE 3, 4				350	ps
t_R/t_F	Output Rise/Fall Time	30% to 70% @ 50MHz	300		700	ps
odc	Output Duty Cycle		47		53	%

All parameters measured at 400MHz unless noted otherwise.

The cycle to cycle jitter on the input will equal the jitter on the output. The part does not add jitter.

NOTE 1: Measured from the differential input crossing point to the differential output crossing point.

NOTE 2: Defined as skew between outputs at the same supply voltage and with equal load conditions.

Measured at output differential cross points.

NOTE 3: Defined as skew between outputs on different devices operating at the same supply voltages and with equal load conditions. Using the same type of inputs on each device, the outputs are measured at the differential cross points.

NOTE 4: This parameter is defined in accordance with JEDEC Standard 65.

PARAMETER MEASUREMENT INFORMATION

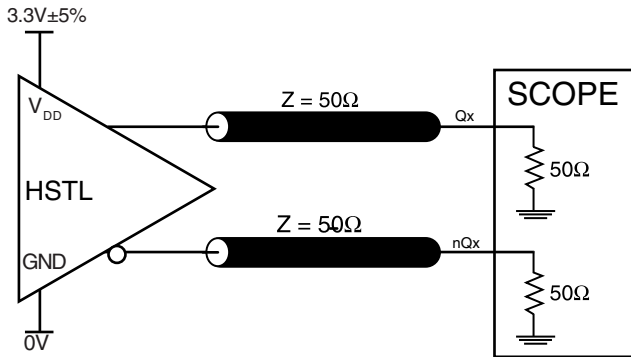

3.3V OUTPUT LOAD AC TEST CIRCUIT

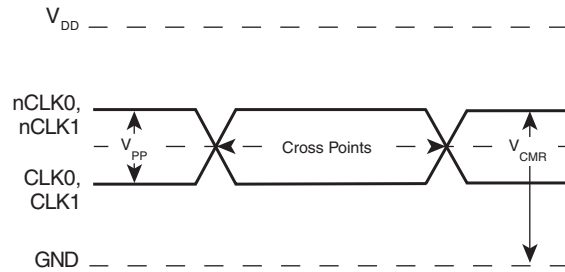

DIFFERENTIAL INPUT LEVEL

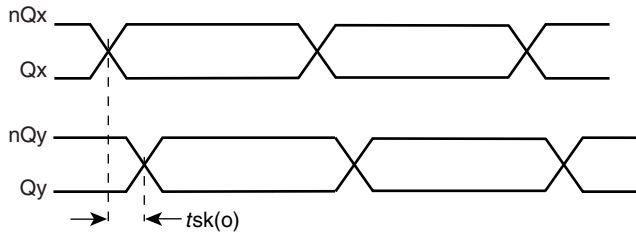

OUTPUT SKEW

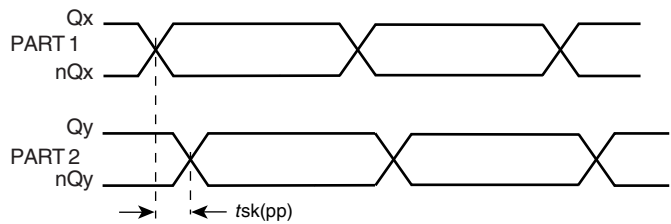

PART-TO-PART SKEW

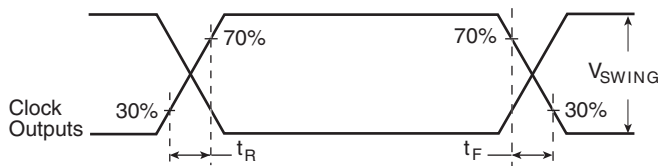

OUTPUT RISE/FALL TIME

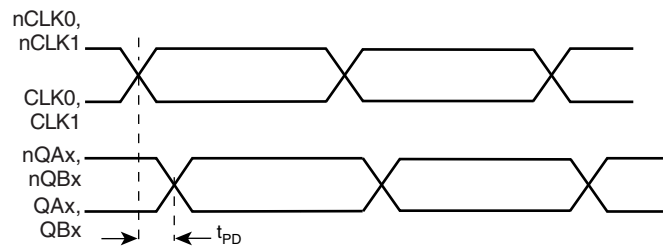

PROPAGATION DELAY

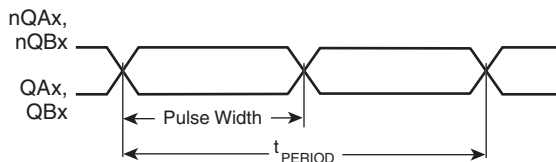

$$odc = \frac{t_{PW}}{t_{PERIOD}}$$

OUTPUT DUTY CYCLE/PULSE WIDTH/PERIOD

APPLICATION INFORMATION

WIRING THE DIFFERENTIAL INPUT TO ACCEPT SINGLE ENDED LEVELS

Figure 1 shows how the differential input can be wired to accept single ended levels. The reference voltage $V_{REF} = V_{DD}/2$ is generated by the bias resistors R1, R2 and C1. This bias circuit should be located as close as possible to the input pin.

of R1 and R2 might need to be adjusted to position the V_{REF} in the center of the input voltage swing. For example, if the input clock swing is only 2.5V and $V_{DD} = 3.3V$, V_{REF} should be 1.25V and $R2/R1 = 0.609$.

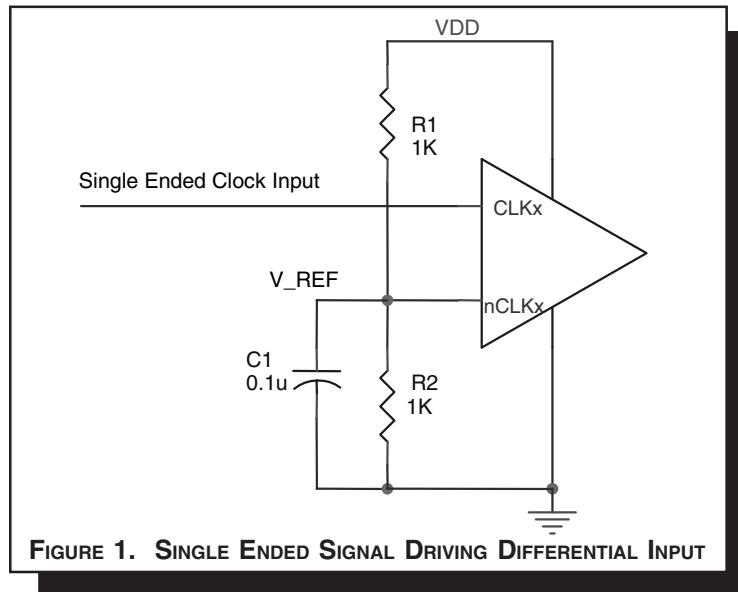

DIFFERENTIAL CLOCK INPUT INTERFACE

The CLK /nCLK accepts LVDS, LVPECL, HSTL, SSTL, HCSSL and other differential signals. Both V_{SWING} and V_{OH} must meet the V_{PP} and V_{CMR} input requirements. Figures 3A to 3E show interface examples for the CLK/nCLK input driven by the most common driver types. The input interfaces suggested here

are examples only. Please consult with the vendor of the driver component to confirm the driver termination requirements. For example in *Figure 3A*, the input termination applies for HSTL drivers. If you are using an HSTL driver from another vendor, use their termination recommendation.

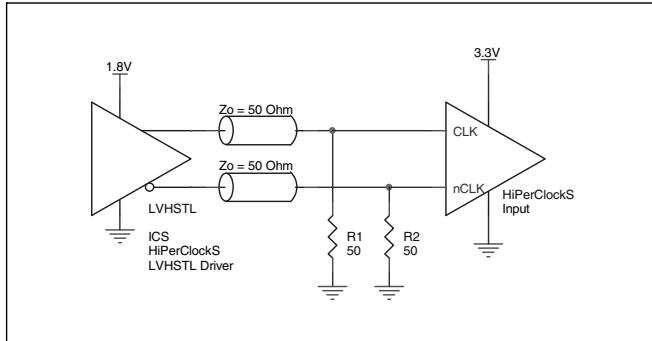

FIGURE 3A. CLK/nCLK INPUT DRIVEN BY HSTL DRIVER

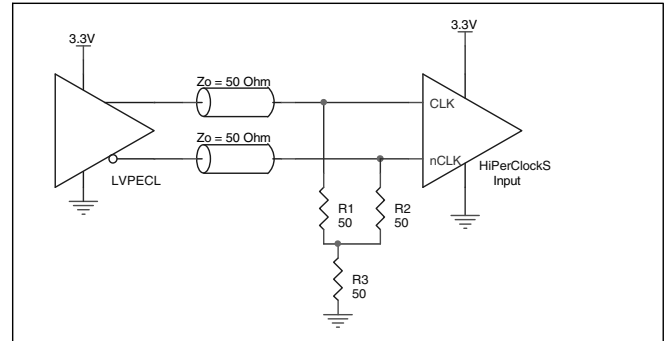

FIGURE 3B. CLK/nCLK INPUT DRIVEN BY 3.3V LVPECL DRIVER

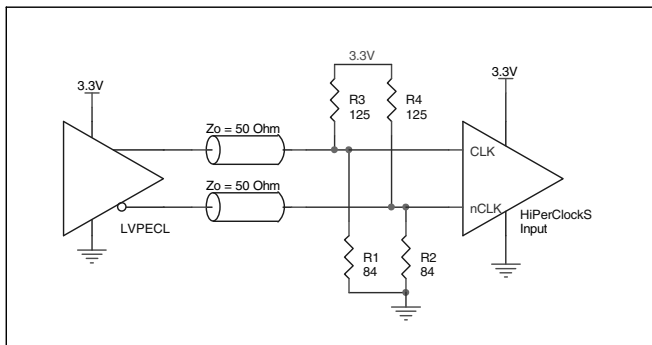

FIGURE 3C. CLK/nCLK INPUT DRIVEN BY 3.3V LVPECL DRIVER

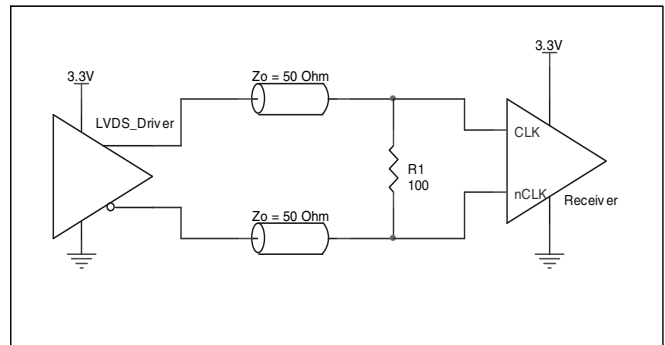

FIGURE 3D. CLK/nCLK INPUT DRIVEN BY 3.3V LVDS DRIVER

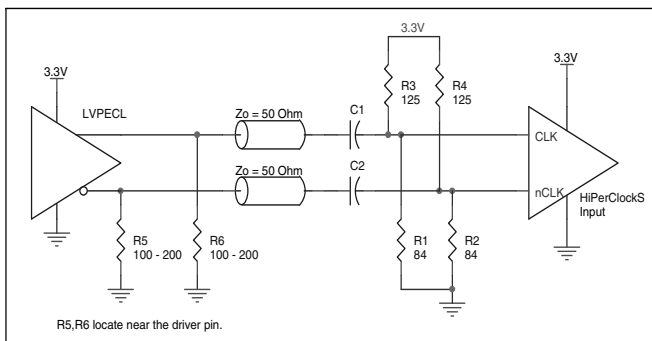

FIGURE 3E. CLK/nCLK INPUT DRIVEN BY 3.3V LVPECL DRIVER WITH AC COUPLE



POWER CONSIDERATIONS

This section provides information on power dissipation and junction temperature for the ICS85210-21. Equations and example calculations are also provided.

1. Power Dissipation.

The total power dissipation for the ICS85210-21 is the sum of the core power plus the power dissipated in the load(s). The following is the power dissipation for $V_{DD} = 3.3V + 5\% = 3.465V$, which gives worst case results.

NOTE: Please refer to Section 3 for details on calculating power dissipated in the load.

- Power (core)_{MAX} = $V_{DD_MAX} * I_{DD_MAX} = 3.465V * 120mA = 416mW$
- Power (outputs)_{MAX} = **32.8mW/Loaded Output pair**
 If all outputs are loaded, the total power is $10 * 32.8mW = 328mW$

Total Power_{MAX} (3.465V, with all outputs switching) = $416mW + 328mW = 744mW$

2. Junction Temperature.

Junction temperature, T_j, is the temperature at the junction of the bond wire and bond pad and directly affects the reliability of the device. The maximum recommended junction temperature for the devices is 125°C.

The equation for T_j is as follows: $T_j = \theta_{JA} * Pd_total + T_A$

T_j = Junction Temperature

θ_{JA} = Junction-to-Ambient Thermal Resistance

Pd_{total} = Total Device Power Dissipation (example calculation is in section 1 above)

T_A = Ambient Temperature

In order to calculate junction temperature, the appropriate junction-to-ambient thermal resistance θ_{JA} must be used. Assuming a moderate air flow of 200 linear feet per minute and a multi-layer board, the appropriate value is 42.1°C/W per Table 5 below. Therefore, T_j for an ambient temperature of 70°C with all outputs switching is:

$70^\circ C + 0.744W * 42.1^\circ C/W = 101^\circ C$. This is well below the limit of 125°C

This calculation is only an example. T_j will obviously vary depending on the number of loaded outputs, supply voltage, air flow, and the type of board (single layer or multi-layer).

TABLE 5. THERMAL RESISTANCE θ_{JA} FOR 32-PIN LQFP, FORCED CONVECTION

θ_{JA} by Velocity (Linear Feet per Minute)			
	0	200	500
Single-Layer PCB, JEDEC Standard Test Boards	67.8°C/W	55.9°C/W	50.1°C/W
Multi-Layer PCB, JEDEC Standard Test Boards	47.9°C/W	42.1°C/W	39.4°C/W

NOTE: Most modern PCB designs use multi-layered boards. The data in the second row pertains to most designs.

3. Calculations and Equations.

The purpose of this section is to derive the power dissipated into the load.

HSTL output driver circuit and termination are shown in *Figure 3*.

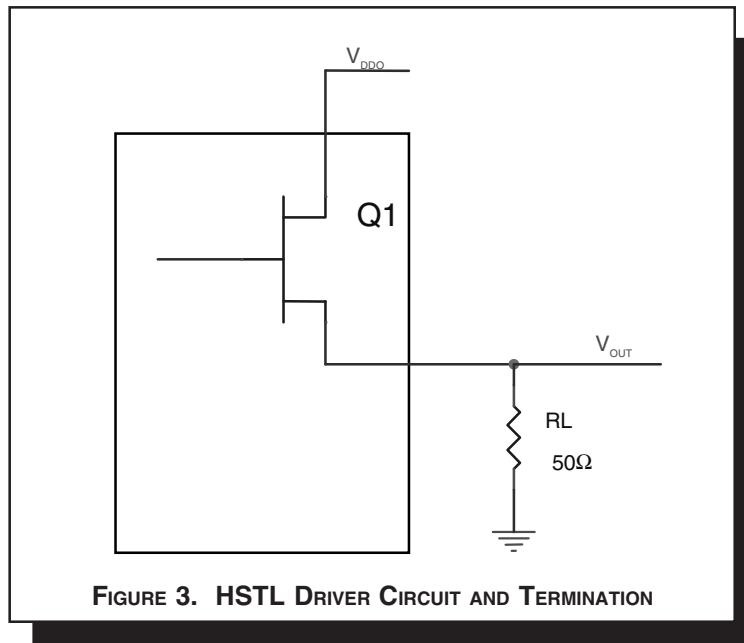

To calculate worst case power dissipation into the load, use the following equations which assume a 50Ω load.

Pd_H is power dissipation when the output drives high.
 Pd_L is the power dissipation when the output drives low.

$$Pd_H = (V_{OH_MIN} / R_L) * (V_{DDO_MAX} - V_{OH_MIN})$$

$$Pd_L = (V_{OL_MAX} / R_L) * (V_{DDO_MAX} - V_{OL_MAX})$$

$$Pd_H = (1V/50\Omega) * (2V - 1V) = \mathbf{20mW}$$

$$Pd_L = (0.4V/50\Omega) * (2V - 0.4V) = \mathbf{12.8mW}$$

Total Power Dissipation per output pair = Pd_H + Pd_L = **32.8mW**



RELIABILITY INFORMATION

TABLE 6. θ_{JA} VS. AIR FLOW TABLE FOR 32 LEAD LQFP

θ_{JA} by Velocity (Linear Feet per Minute)			
	0	200	500
Single-Layer PCB, JEDEC Standard Test Boards	67.8°C/W	55.9°C/W	50.1°C/W
Multi-Layer PCB, JEDEC Standard Test Boards	47.9°C/W	42.1°C/W	39.4°C/W

NOTE: Most modern PCB designs use multi-layered boards. The data in the second row pertains to most designs.

TRANSISTOR COUNT

The transistor count for ICS85210-21 is: 1216

PACKAGE OUTLINE - Y SUFFIX FOR 32 LEAD LQFP

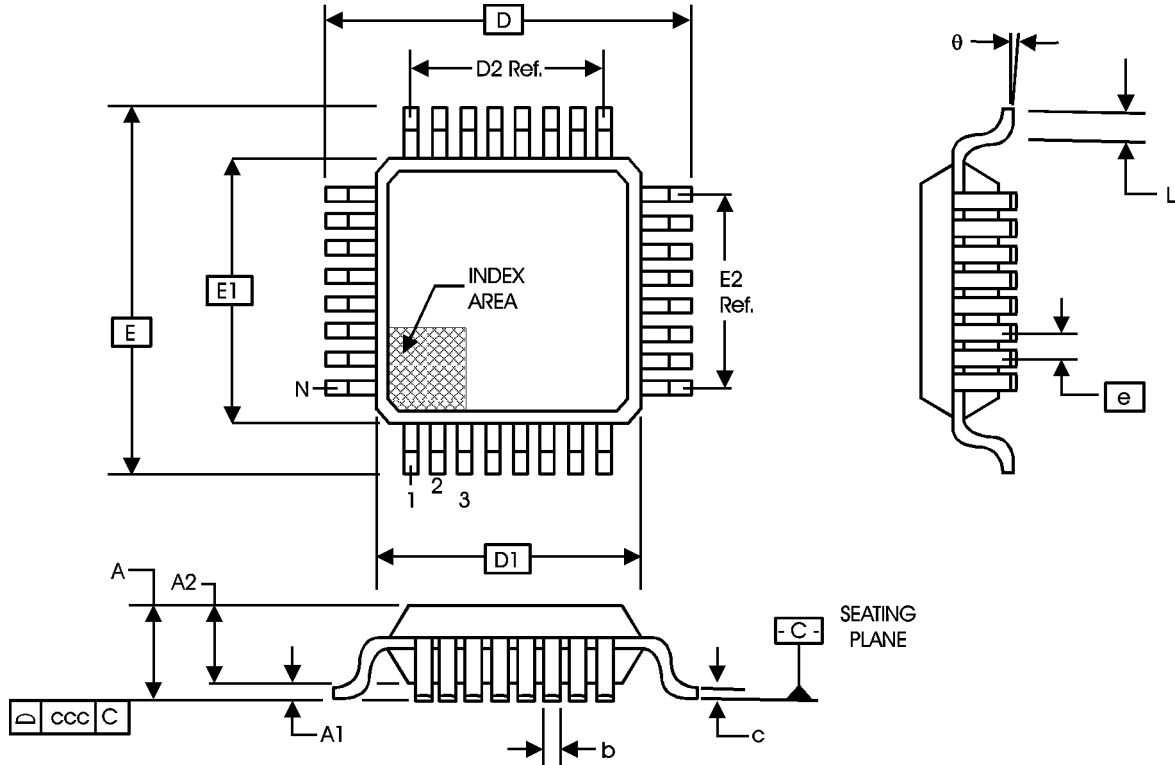

TABLE 7. PACKAGE DIMENSIONS

JEDEC VARIATION ALL DIMENSIONS IN MILLIMETERS			
SYMBOL	BBA		
	MINIMUM	NOMINAL	MAXIMUM
N	32		
A	--	--	1.60
A1	0.05	--	0.15
A2	1.35	1.40	1.45
b	0.30	0.37	0.45
c	0.09	--	0.20
D	9.00 BASIC		
D1	7.00 BASIC		
D2	5.60 Ref.		
E	9.00 BASIC		
E1	7.00 BASIC		
E2	5.60 Ref.		
e	0.80 BASIC		
L	0.45	0.60	0.75
theta	0°	--	7°
ccc	--	--	0.10

Reference Document: JEDEC Publication 95, MS-026



ICS85210-21
LOW SKEW, DUAL, 1-TO-5
DIFFERENTIAL-TO-HSTL FANOUT BUFFER

TABLE 8. ORDERING INFORMATION

Part/Order Number	Marking	Package	Shipping Packaging	Temperature
85210AY-21	ICS85210AY-21	32 lead LQFP	tray	0°C to 70°C
85210AY-21T	ICS85210AY-21	32 lead LQFP on Tape and Reel	1000	0°C to 70°C

While the information presented herein has been checked for both accuracy and reliability, Integrated Device Technology, Inc. (IDT) assumes no responsibility for either its use or for infringement of any patents or other rights of third parties, which would result from its use. No other circuits, patents, or licenses are implied. This product is intended for use in normal commercial and industrial applications. Any other applications such as those requiring high reliability, or other extraordinary environmental requirements are not recommended without additional processing by IDT. IDT reserves the right to change any circuitry or specifications without notice. IDT does not authorize or warrant any IDT product for use in life support devices or critical medical instruments.



ICS85210-21
LOW SKEW, DUAL, 1-TO-5
DIFFERENTIAL-TO-HSTL FANOUT BUFFER

REVISION HISTORY SHEET				
Rev	Table	Page	Description of Change	Date
A	1	2	Throughout data sheet changed LVHSTL to HSTL.	10/6/03
	2	2	Pin Description Table changed V_{DD} description from Positive to Core.	
		2	Pin Characteristics Table - changed C_{IN} 4pF max. to 4pF typical.	
		6	Revised Single Ended Signal Driving Differential Input diagram.	
7	Added Differential Clock Input Interface section.			
			Updated data sheet format.	
B	T8	12	Updated datasheet's header/footer with IDT from ICS.	7/25/10
		14	Removed ICS prefix from Part/Order Number column. Added Contact Page.	



ICS85210-21
LOW SKEW, DUAL, 1-TO-5
DIFFERENTIAL-TO-HSTL FANOUT BUFFER

We've Got Your Timing Solution.



6024 Silver Creek Valley Road
San Jose, CA 95138

Sales
800-345-7015 (inside USA)
+408-284-8200 (outside USA)
Fax: 408-284-2775

Tech Support
netcom@idt.com

© 2010 Integrated Device Technology, Inc. All rights reserved. Product specifications subject to change without notice. IDT, the IDT logo, ICS and HiPerClockS are trademarks of Integrated Device Technology, Inc. Accelerated Thinking is a service mark of Integrated Device Technology, Inc. All other brands, product names and marks are or may be trademarks or registered trademarks used to identify products or services of their respective owners.
Printed in USA