

INTRODUCTION

The S1M8653B is a baseband analog processing IC for dual-mode CDMA/FM portable cellular telephones. The S1M8653B interfaces between the analog RF and digital processing sections of the cellular phone. The receive circuit functions primarily to translate analog IF signals to the baseband frequency range and convert analog baseband signals into digital signals. Transmit circuits convert digital data into analog baseband signals which are then up-converted to the IF frequency band. The analog inputs and outputs of the S1M8653B interface with IF transmit/receive circuitry of telephones; the digital inputs and outputs interface directly with the Mobile Station Modem (MSM).

80-LQFP-1212

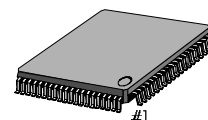

FEATURES

- Dual-mode for CDMA/FM operation
- Receive signal path includes:
 - IF to baseband down converter
 - Built-in low pass filter
 - Two 4-bit ADCs
 - Local Oscillator
- General purpose 8-bit ADC for system monitoring
- Power saving modes
- Single 3.3V power supply
- 80 pin LQFP package
- S1M8653BQ: CDMA/FM Dual
- Transmit signal path includes:
 - Two 8-bit DACs
 - Base-band to IF up converter
 - Local Oscillator
 - Built-in low pass filter

APPLICATIONS

- Dual-mode CDMA/FM cellular telephones

ORDERING INFORMATION

Device	Package	Operating Temperature
S1M8653BQ	80-QFP-1212	-40 to +85°C

SYSTEM BLOCK DIAGRAM

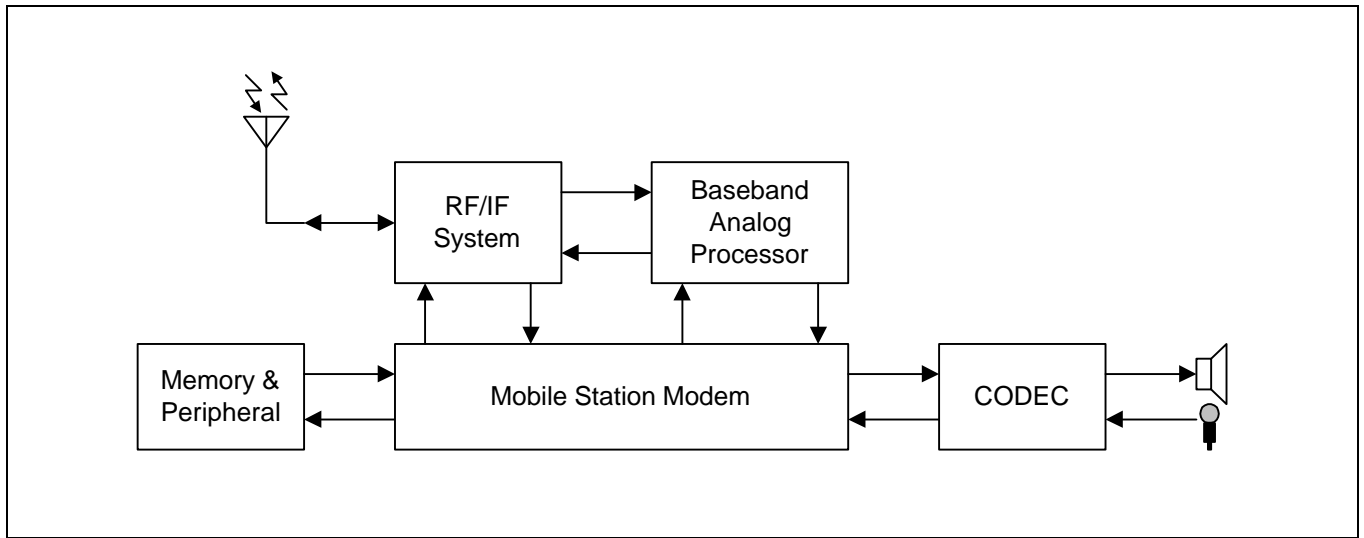

Figure 1. Dual Mode CDMA/FM Cellular Telephone Block

BLOCK DIAGRAM

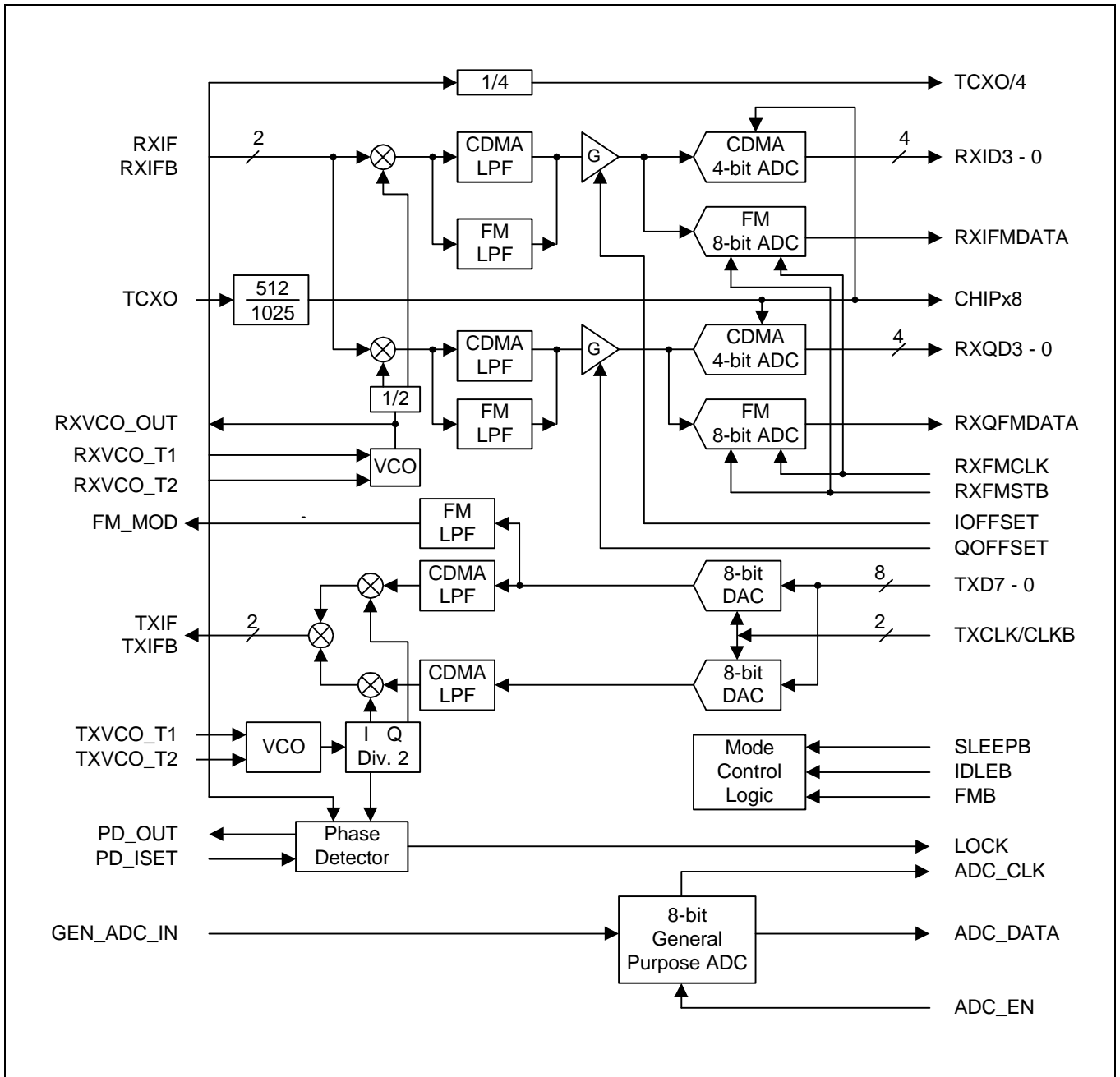

Figure 2. Block Diagram

PIN CONFIGURATION

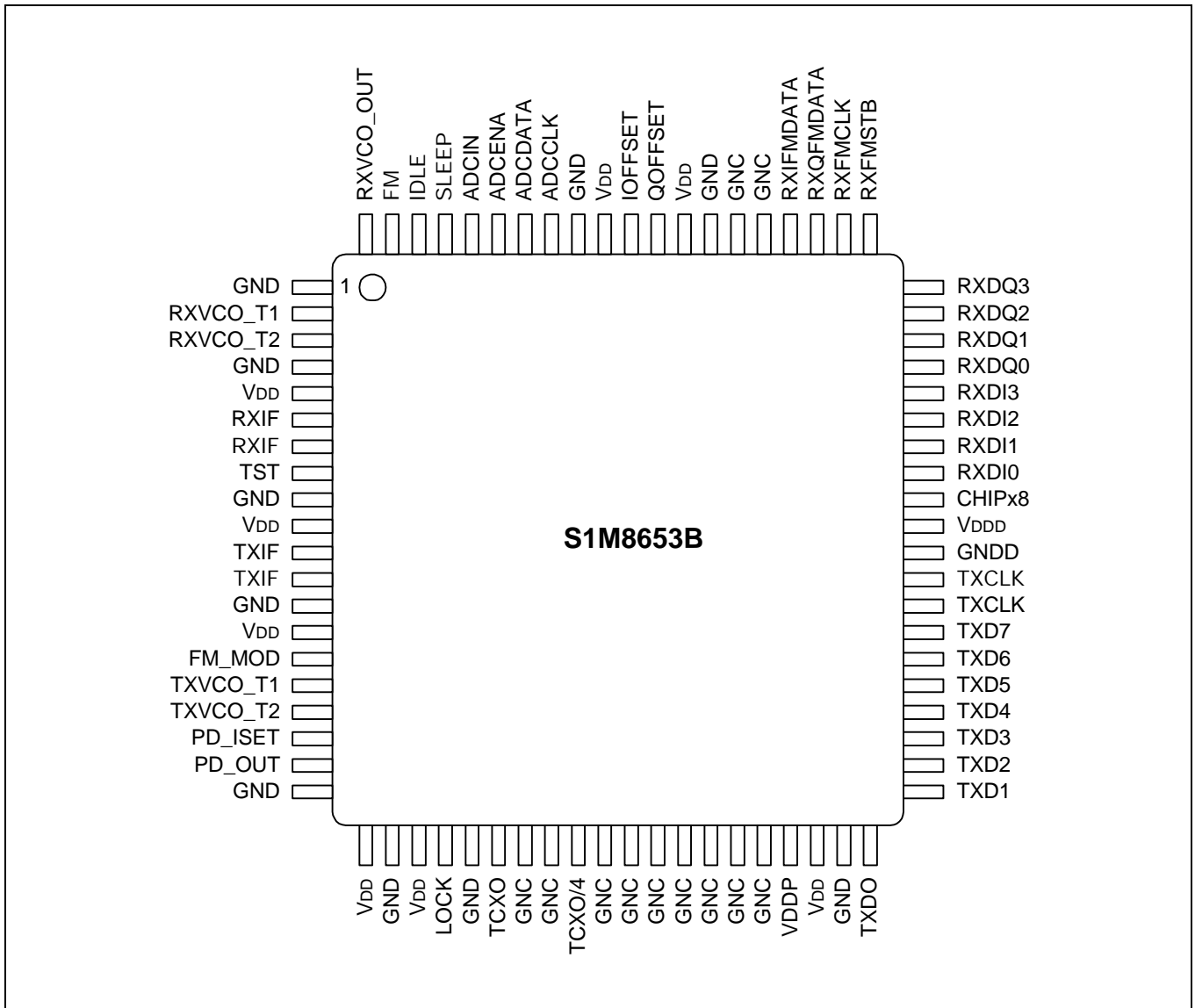

Figure 3. Pin Configuration

PIN DESCRIPTION

Pin No.	Symbol	Type	Equivalent Circuit	Description
1,4,9,13	GND	P		Analog Ground
2	RXVCO_T1	I		The receive VCO tuning pins connect to an external LC tank circuit for precise setting of the receive VCO frequency. The receive VCO is active in RXTX and IDLE modes for CDMA and FM. In SLEEP mode, these pins are pulled high.
3	RXVCO_T2	I		
5,10,14	VDD	P		Analog Power (+3.3V).
6	RXIF	I		Analog differential receive IF inputs. These pins are active in RXTX and IDLE modes for CDMA and FM. In SLEEP mode, these pins are pulled low.
7	RXIF	I		
8	TST	I		This pin is used during testing. Connect to analog GND.
11	TXIF	O		Analog differential transmit IF outputs. These pins are active in CDMA and FM RXTX modes. In all other modes, these pins are pulled high.
12	TXIF	O		
15	FM_MOD	O		Analog FM modulation signal output. It is active in FM RXTX mode only. When inactive, it is pulled low.

PIN DESCRIPTION (Continued)

Pin No.	Symbol	Type	Equivalent Circuit	Description
16	TXVCO_T1	I		<p>The transmit VCO tuning pins connect to an external LC tank circuit for precise setting of the transmit VCO frequency. The transmit VCO is active in CDMA and FM RXTX modes.</p> <p>In all other modes, these pins are pulled high.</p>
17	TXVCO_T2	I		
18	PD_ISET	I		Sets PD_OUT current level.
19	PD_OUT	O		Transmit synthesizer phase detector charge pump output. When inactive, goes to high impedance state.
20,22,25	GND	P		Analog Ground.
21,23	V _{DD}	P		Analog Power.
24	LOCK	O		Transmit IF synthesizer lock detector output. Active in CDMA and FM RXTX modes. LOCK is an open drain, pulled high by an external pull-up resistor when inactive.
26	TCXO	I		An externally generated 19.68MHz clock frequency is applied to this pin. It is active in all modes.

PIN DESCRIPTION (Continued)

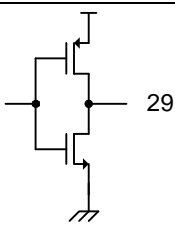
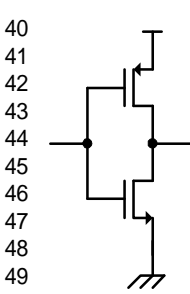
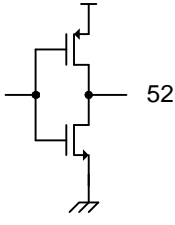
Pin No.	Symbol	Type	Equivalent Circuit	Description
27, 28	GNC	-		These pins are used during testing. Connect to analog GND.
29	TCXO/4	O		A clock frequency equal to 1/4 of the TCXO frequency is output on this pin in all operating modes.
30,31,32,33,34,35,36,37	GND	P		These pins are used during testing. Connect to analog GND.
38	V _{DD}	P		Digital Power.
39	GND	P		Digital GND.
40-47	TXD0-TXD7	I		Transmit data input pins for transmit 8-bit D/A converter TXD7 is the MSB.
48	TXCLK	I		Complementary inputs to transmit D/A converter.
49	TXCLK	I		
50	GND	P		Digital Ground.
51	V _{DD}	P		Digital Power.
52	CHIPx8	O		The CHIPx8 synthesizer is a digital divider with a ratio of 512/1025 times the TCXO input frequency. As such, it will have an average output frequency of 9.8304MHz, but will not have an exact 50% duty cycle. When the CHIPx8 synthesizer is disabled (CDMA SLEEP and FM RX modes) the CHIPx8 signal is pulled to a logic low.

PIN DESCRIPTION (Continued)

Pin No.	Symbol	Type	Equivalent Circuit	Description
53–56	RXDI0–RXDI3	O		CDMA I receive data is output to the MSM on this 4-bit port. RXDI3 is the MSB. Active in CDMA RXTX and CDMA IDLE, otherwise logic low.
57–60	RXDQ0–RXDQ3	O		CDMA Q receive data is output to the MSM on this 4-bit port. RXDQ3 is the MSB. Active in CDMA RXTX and CDMA IDLE, otherwise logic low.
61	RXFMSTB	I		Receive FM data strobe. Active in FM RXTX and FM IDLE modes. Pulled high if left unconnected.
62	RXFMCLK	I		Receive FM data clock. Active in FM RXTX and FM IDLE modes. Pulled high if left unconnected.
63	RXQFMDATA	O		Receive FM Q serial data output. Active in FM RXTX and FM IDLE modes. High when inactivated.
64	RXIFMDATA	O		Receive FM I serial data output. Active in FM RXTX and FM IDLE modes. High when inactivated.
65, 66	GNC	–		These pins are used during testing. Connect to analog ground..
67	GND	P		Analog Ground.
68	V _{DD}	P		Analog Power.
69	QOFFSET	I		Q channel offset adjust input for CDMA and RXTX and IDLE modes. The MSM derives a PDM signal which is filtered by an external RC at the pin.
70	IOFFSET	I		I channel offset adjust input for CDMA and RXTX and IDLE modes. The MSM derives a PDM signal which is filtered by an external RC at the pin.

PIN DESCRIPTION (Continued)

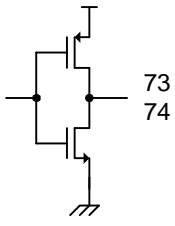
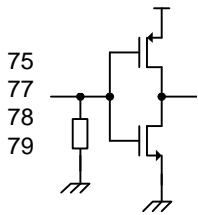
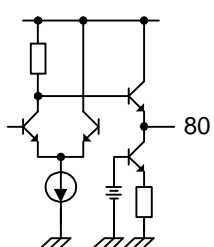
Pin No.	Symbol	Type	Equivalent Circuit	Description
71	V _{DD}	P		Analog Power.
72	NC			No connection.
73	ADCCLK	O		General Purpose ADC clock output. When high, valid data is available on ADCDATA. Low when inactive.
74	ADCDATA	O		General Purpose ADC serial data output. Valid data is available when ADCCLK is high. Low when inactive.
75	ADCENA	I		The General Purpose ADC is enabled and a conversion is initiated by a positive-going pulse on this input. Pulled low when inactive.
76	ADCIN	I		General Purpose A/D analog input. The voltage applied to this input is digitized by 8-bit general Purpose ADC when ADCENA is pulsed high.
77	SLEEP	I		CDMA SLEEP mode is invoked when this pin is low and FM is high. Pulled low if left unconnected.
78	IDLE	I		CDMA IDLE or FM IDLE modes are invoked when this input is low and SLEEP is high. Pulled low if left unconnected.
79	FM	I		FM or CDMA mode select. Pulled low if left unconnected.
80	RXVCO_OUT	O		Receive VCO output. Active in CDMA and FM RXTX and IDLE modes. Pulled low when inactive.

FUNCTIONAL DESCRIPTION

The Samsung S1M8653B is an IC that bridges the gap between the analog RF and digital processing sections of the cellular telephone as shown in Figure 1. The S1M8653B receive signal path translates the acquired IF signal centered at 85.38 MHz (or 220.38MHz) to base-band where it is then converted to digital data. The digital baseband signals are sent to the MSM for demodulation. When transmitting, the MSM sends modulated digital baseband signals to the S1M8653B for up conversion to analog IF signals centered at 130.38MHz.

The MSM handles various digital data according to the CDMA/AMPS standards. It directly interfaces with the RF/IF sections of the telephone for automatic gain control (AGC) and calibration of the RF signal paths for receive and transmit. In addition, the MSM performs other miscellaneous digital processing in the CDMA/FM cellular telephone.

RECEIVE SIGNAL PATH

The S1M8653B receive signal path(see Figure 3) is designed to accept differential IF signals with CDMA spread spectrum modulation extending $\pm 630\text{kHz}$ from the IF center frequency of 85.38MHz(or 220.38MHz). The incoming IF signal is reduced to I and Q base-band components by mixing with 85.38MHz local oscillator (LO) signals in quadrature followed by low pass filtering.

The 85.38MHz I and Q LO signals are generated on the S1M8653B. The receive VCO is set to 170.76MHz (or 440.76MHz) by an external varactor tuned resonant tank circuit (inductor L and capacitor C connected in parallel). An external phase lock loop and loop filter network provide the feedback to varactors which tune the VCO to 170.76MHz. A master-slave divide-by-two circuit generates I and Q signals in precise quadrature for the mixers.

The receive signal path splits into CDMA and FM sections from the mixer output. For CDMA, the base-band signal extends from 1kHz to 630kHz. Frequency components above 750kHz are out-of-band for CDMA operation. The mixers and the subsequent CDMA low-pass filters combine to form the down converter which outputs the CDMA base-band signals. The pass-band, transition band, and rejection band characteristics of these low pass filters, in conjunction with external IF band-pass filtering, contribute to the ability of the receiver to select the desired base-band signals from the jamming effects of unwanted signals.

The offset control inputs, IOFFSET and QOFFSET, are used to control the offset at the inputs of the ADCs. The MSM senses the offset of the digital base-band data and creates a pulse density modulated (PDM) signal for compensation through long time-constant RC filters. It makes sure that the number of occurrence of symbols, "1"s and "0"s, in the transmitted data stream is equal. The numbers of the two symbols will differ when DC offset is introduced in the signal path. The MSM eliminates the unwanted offset by applying appropriate compensating control signals to IOFFSET and QOFFSET pins.

The down converted base-band analog signal, generated after passing through analog filters, will be sampled at the falling edges of CHIPx8 clock by two 4 bit flash ADCs, the outputs of which are fed to the MSM as the digital receive data.

The receive signal path for FM operation is similar to that for CDMA operation. Differences lie in the characteristics of the I and Q low pass filters and the ADCs. The IF frequency is the same as in CDMA (85.38MHz or 220.38MHz) but the modulation can only extend $\pm 15\text{kHz}$ from the IF center frequency, forming a 30kHz wide channel. The low pass filters for FM operation have a much lower bandwidth than those used in CDMA. The offset of the FM low pass filters is controlled just like the CDMA low-pass filters by the IOFFSET and QOFFSET input pins.

The lower bandwidth of the FM base-band signal gives rise to the use of very low power 8 bit algorithmic type ADCs. The FM I and Q analog base-band signals are sampled and held during the analog to digital (A/D) conversion process. The A/D conversion is initiated with a strobe from the MSM. A serial data stream is output beginning with the most significant bit(MSB) of the result.

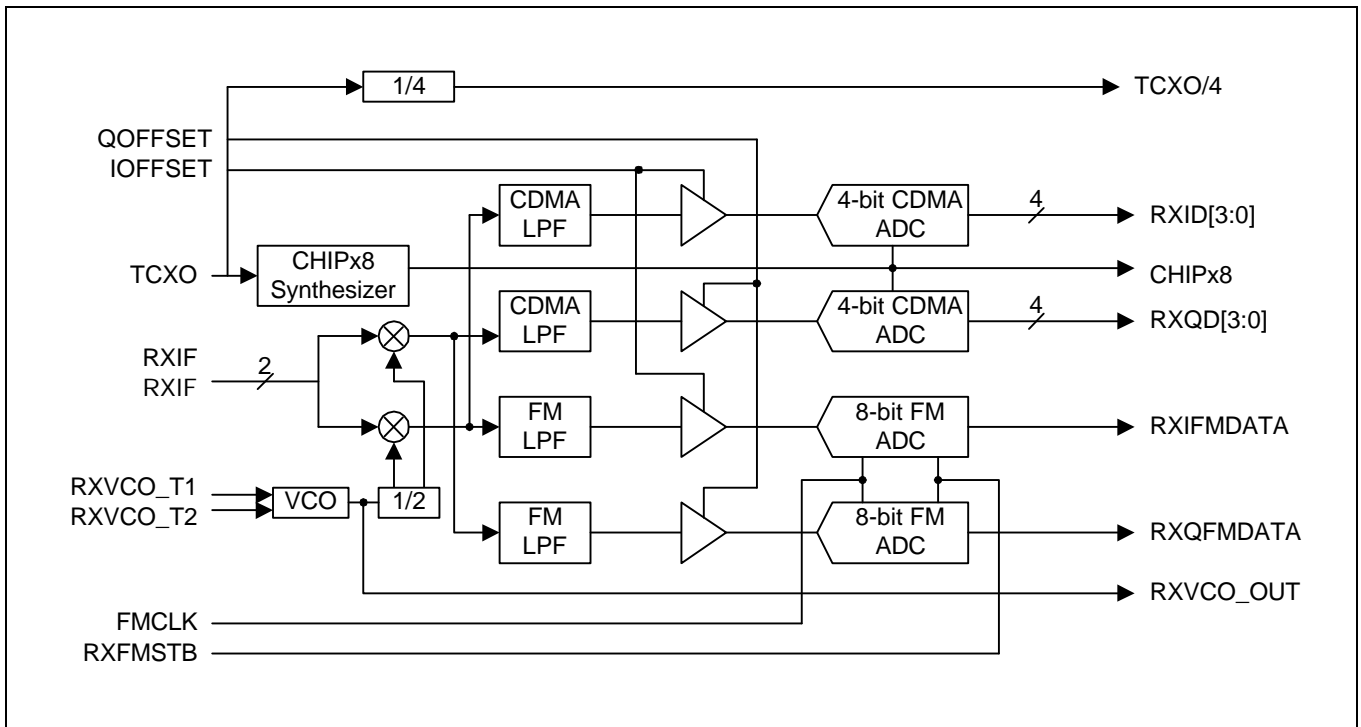

Figure 3. Receive Section Block Diagram

Transmit Signal Path

The S1M8653B transmit signal path accepts eight bits of I and Q baseband transmit data from the MSM and outputs modulated IF signal centered at 130.38MHz to the RF transmitter(See Figure 4). The rising edge of the transmit clock latches incoming data into the I DAC while the falling edge latches data into the Q DAC. The MSM compensates I and Q data values to account for their half cycle time difference.

Undesirable frequency components are found in the spectrum at the output of the DACs due to output transition edges and transients, and the transmit clock. To reduce them, each DAC is followed by an anti-aliasing low pass filter with a bandwidth of 630kHz. Unlike the low pass filters in the receive signal path, these do not require off-set controls.

The S1M8653B outputs differential IF signals with CDMA spread spectrum modulation extending $\pm 630\text{kHz}$ from the transmit IF center frequency of 130.38MHz. The analog I and Q baseband components from the CDMA low-pass filters are mixed in quadrature with local oscillator(LO) signals at 130.38MHz. The result is summed and output differentially. The 130.38MHz I and Q LO signals are generated from the transmit VCO running at 260.76MHz. The VCO frequency is set by an external varactor-tuned resonant tank circuit, and the feedback is provided by an internal phase-lock loop and external loop filter network. A master-slave divide-by-two circuit generates I and Q signals in precise quadrature for the mixers.

An analog FM modulation signal is constructed from 8-bit digital data supplied by the MSM. Only the Q-channel DAC is used in the S1M8653B in FM mode, all other CDMA circuits are disabled. The DAC output is filtered by a low pass anti-aliasing filter and output as the analog FM modulation signal, FM_MOD.

A low speed, 8-bit resolution, successive approximation General Purpose(GP) ADC provides DC measurement capability to the telephone. It digitizes DC voltages applied to the ADCIN pin from battery level, temperature, and other low frequency control or monitoring sensors.

The GP ADC is in a power-down state during normal S1M8653B operation. It is activated by a positive-going pulse on ADCENA. When this input is driven high, it powers up, samples and holds the voltage applied to ADCIN, and begins a conversion. The ADC output is available from a serial digital interface. Each of the eight data bits is valid (MSB first) during the rising edge of the ADCCLK output. When the LSB of the conversion has been clocked out, the conversion is complete and the ADC returns to a power-down condition. The ADCCLK and ADCDATA outputs will be low before and after a conversion. Conversions can only be started when the ADC is inactive after a conversion has been completed. A rising edge of ADCENA during a conversion will be ignored. ADCENA must be low and a conversion completed before a new conversion can be started.

The S1M8653B has several modes of operation. The CDMA RXTX or FM RXTX modes are in effect when the telephone is making a call. IDLE mode is in effect when no call is in progress but the telephone receive is active (ready to answer a call). SLEEP mode is a low-power mode in which the telephone can not receive a call but the digital processor and keypad are enabled. In Slotted Paging mode, the MSM toggles itself and the S1M8653B between SLEEP and IDLE modes using a programmable timing interval. This mode allows the telephone to be contacted by the base station without requiring the telephone to be continuously in IDLE mode. Slotted Paging mode consumes much less power than IDLE mode.

The states of three digital inputs, FM, IDLE, SLEEP, define the operating modes of the S1M8653B (see Table 1). These logic signals come directly from the MSM and minimize the power consumed by the S1M8653B by disabling unused circuits.

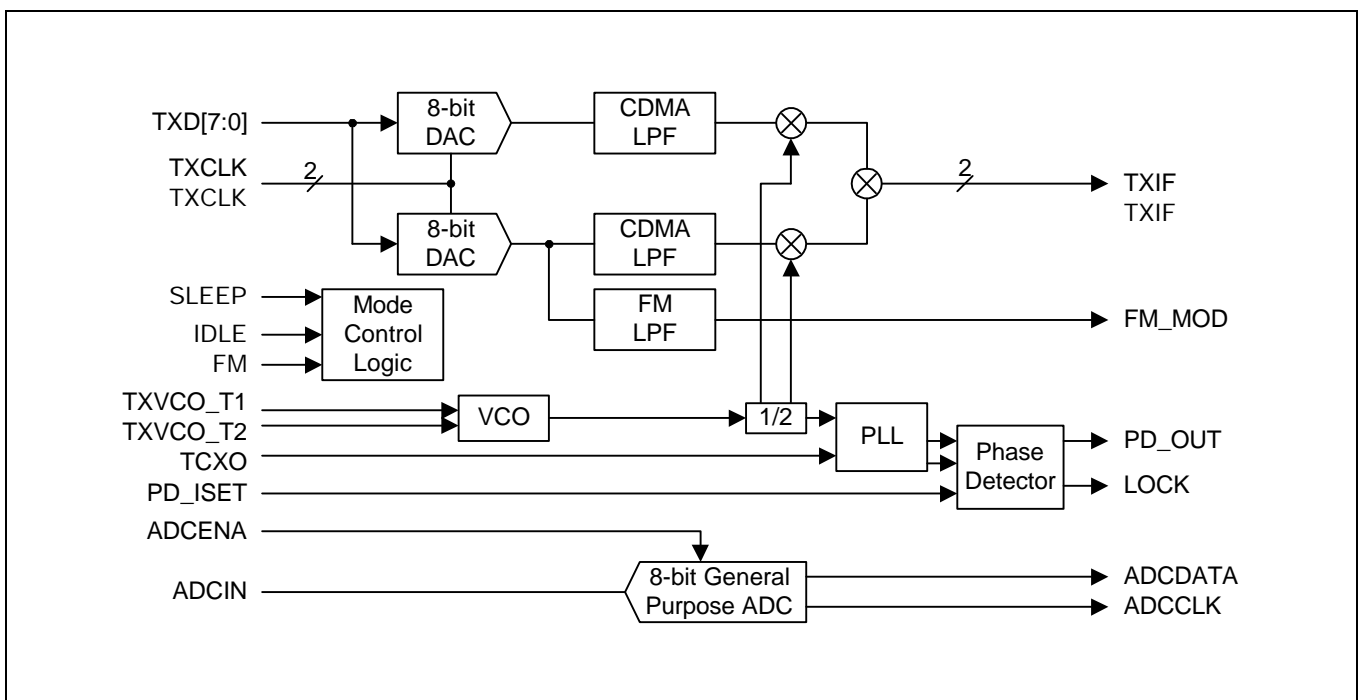

Figure 4. Transmit Section Block Diagram

MODES OF OPERATION

Mode		SLEEP	IDLE	FM
Sleep	(CDMA)	0	X	X
Idle	(CDMA)	1	0	1
RXTX	(CDMA)	1	1	1
Idle	(FM)	1	0	0
RXTX	(FM)	1	1	0

ABSOLUTE MAXIMUM RATINGS

Characteristic	Symbol	Value	Unit
Power supply voltage	V_{CC}	5.0	V
Voltage applied to inputs	V_A	$V_{DD} + 0.5$	V
Operating temperature	T_{OPR}	-40 to +85	°C
Storage temperature	T_{STG}	-55 to +125	°C

RECOMMENDED OPERATING CONDITIONS

Characteristic	Symbol	Test Conditions	Min.	Typ	Max.	Units
Power supply voltage	V_{CC}		3.0	-	3.6	V
Ambient operating temperature	T_a		-40	-	85	°C

ELECTRICAL CHARACTERISTICS ($V_{CC} = 3.3V$, $T_a = 25^\circ C$)

Characteristic	Symbol	Test Conditions	Min.	Typ	Max.	Units
Power supply current	I_{CC1}	CDMA RXTX mode	-	35	50	mA
Power supply current	I_{CC2}	CDMA IDLE mode	-	20	30	mA
Power supply current	I_{CC3}	CDMA SLEEP mode	-	0.5	1.4	mA
Power supply current	I_{CC4}	FM RXTX mode	-	25	-	mA
Power supply current	I_{CC5}	FM IDLE mode	-	13	-	mA
Power supply rejection ratio	PSRR		-	TBD	-	dB
Logic high input voltage	V_{IH}		$V_{DD}-0.7$	-	-	V
Logic low input voltage	V_{IL}		-	-	0.3	V
Logic high output voltage	V_{OH}	$V_{DD} = 3.0V$	2.7	-	-	V
Logic low output voltage	V_{OL}	$V_{DD} = 3.6V$	-	-	0.4	V

ELECTRICAL CHARACTERISTICS (Continued) ($V_{CC} = 3.3V$, $T_a = 25^\circ C$)

Characteristic	Symbol	Test Conditions	Min.	Typ	Max.	Units
Logic input leakage current	I_{LC}	$V_{DD} = \text{MAX.}$ $V_{IN} = \text{GND to } V_{DD}$	-	-	± 100	μA
Input capacitance, digital input	C_{ID}		-	4	-	pF
Digital output load capacitance	C_{LD}		-	5	-	pF
Digital output load resistance	R_{LD}		100K	-	-	Ω
Input resistance of RX IF input pins	R_{IRXI}	RXIF to RXIF, differential	-	500	-	Ω
Input capacitance of RX IF input pins	C_{IRXI}	RXIF and RXIF to ground	-	4	-	pF
Input impedance of offset adjust pins	Z_{IOFF}	IOFFSET, QOFFSET	200K	-	-	Ω
Load resistance of TX IF output-pins	R_{LTXI}	TXIF to TXIF, differential	-	500	-	Ω
Load capacitance of TX IF output pins	C_{LTXI}	TXIF, TXIF to ground	-	4	-	pF
Output impedance of TX IF output pins	Z_{OTXI}	TXIF to TXIF differential	-	50	-	Ω
VCO tuning circuit input impedance	Z_{IVCO}	RXVCO_T1, RXVCO_T2, TXVCO_T1, TXVCO_T2	-	2K	-	Ω
PD_OUT output impedance	Z_{OPD}	Within compliance range	1M	-	-	Ω
LOCK output logic low voltage	V_{OLLK}	$R_{LD} \geq 10\mu$ to V_{DD}	-	-	0.4	V
LOCK output leakage current	I_{LLK}	$V_{out} = V_{DD}$	-	-	1	μA
TCXO input impedance	Z_{ITCX}		-	4K	-	Ω
General purpose ADC input impedance	Z_{IGADC}	ADCIN	20K	50K	-	Ω
General purpose ADC input signal range	V_{SGADC}		0.5	-	2.5	V

SWITCHING CHARACTERISTICS ($V_{CC} = 3.3V$, $T_a = 25^\circ C$)

Characteristic	Symbol	Test Conditions	Min.	Typ	Max.	Units
TXCLK high time	t_{TXCH}	CDMA transmit, figure 5	-	50.8	-	ns
TXCLK low time	t_{TXCL}	CDMA transmit, figure 5	-	50.8	-	ns
TXCLK period	t_{TXCY}	CDMA transmit, figure 5	-	101.6	-	ns
Data set-up to TXCLK transition	t_{SU}	CDMA and FM TX, figure 5, 6	20	-	-	ns
Data hold after TXCLK transition	t_H	CDMA and FM TX, figure 5, 6	3	-	-	ns
10% to 90% rise time	t_R	CDMA and FM TX, figure 5, 6	-	-	12	ns
90% to 10% fall time	t_F	CDMA and FM TX, figure 5, 6	-	-	12	ns
TXCLK to TXCLK phase delay	t_{PH}	CDMA and FM TX, figure 5, 6	-	-	10	% of t_F , t_R
TXCLK high time	t_{TXFCH}	FM transmit, figure 6	-	1.39	-	ns
TXCLK low time	t_{TXFCL}	FM transmit, figure 6	-	1.39	-	ns
TXCLK period	t_{TXFCY}	FM transmit, figure 6	-	2.78	-	ns
CHIPx8 high time	t_{x8H}	Figure 7, 10	-	50.8	-	ns
CHIPx8 low time	t_{x8L}	Figure 7, 10	-	50.8	-	ns
CHIPx8 period	t_{x8BCY}	Figure 7, 10	-	101.6	-	ns
Digital output delay after CHIPx8 fall	t_{DO}	Figure 7	-	-	20	ns
10% to 90% rise time	t_{x8R}	Figure 7	3	-	12	ns
90% to 10% fall time	t_{x8F}	Figure 7	3	-	12	ns
FMCLK high time	t_{FMCKH}	FM receive ADC, figure 8	1	1.39	-	μs
FMCLK low time	t_{FMCKL}	FM receive ADC, figure 8	1	1.39	-	μs
FMCLK period	t_{FMCKY}	FM receive ADC, figure 8	-	2.78	-	μs
RXFMSTB pulse width high	t_{STBPW}	FM receive ADC, figure 8	1	-	-	μs
Strobe input valid to FMCLK falling edge	t_{SUS}	FM receive ADC, figure 8	50	-	-	ns

SWITCHING CHARACTERISTICS (Continued) ($V_{CC} = 3.3V$, $T_a = 25^\circ C$)

Characteristic	Symbol	Test Conditions	Min.	Typ	Max.	Units
Strobe input valid after FMCLK falling edge	t_{HS}	FM receive ADC, figure 8	50	-	-	ns
10% to 90% rise time	t_{FMR}	FM receive ADC, figure 8	-	-	12	ns
90% to 10% falling time	t_{FMF}	FM receive ADC, figure 8	-	-	12	ns
Output delay after FMCLK rising edge	t_{DOF}	RXQFMDATA, RXIFMDATA, FM receive ADC, figure 8	-	-	50	ns
Enable pulse width high	t_{ENPWH}	Figure 9	100	-	-	ns
Enable pulse width low	t_{ENPWL}	Figure 9	100	-	-	ns
ADCENA high to ADCCLK	t_{ENCK}	Figure 9	-	20	-	μs
ADCCLK low	t_{GCL}	Figure 9	-	1.22	-	μs
ADCCLK high	t_{GCH}	Figure 9	-	1.22	-	μs
ADCCLK period	t_{GCY}	Figure 9	-	2.44	-	μs
10% to 90% rise time	t_{GR}	Figure 9	-	-	12	ns
90% to 10% fall time	t_{GF}	Figure 9	-	-	12	ns
ADCENA high to conversion end	t_{TOC}	Figure 9	-	-	40	μs
ADCDATA delay after ADCCLK falling edge	t_{GDO}	Figure 9	-	20	-	ns
ADCDATA valid before ADCCLK rising edge	t_{GSU}	Figure 9	-	1	-	μs
TCXO low time	t_{XLCL}	Figure 10	-	25.4	-	ns
TCXO high time	t_{XLCH}	Figure 10	-	25.4	-	ns
TCXO period	t_{XLCY}	Figure 10	-	50.8	-	ns
10% to 90% rise time	t_{XLR}	Figure 10	-	-	10	ns
90% to 10% fall time	t_{XLF}	Figure 10	-	-	10	ns
TCXO/4 low time	t_{XL4CL}	Figure 10	-	50.8	-	ns
TCXO/4 high time	t_{XL4CF}	Figure 10	-	50.8	-	ns
TCXO/4 period	t_{XL4CY}	Figure 10	-	101.6	-	ns

TIMING DIAGRAM

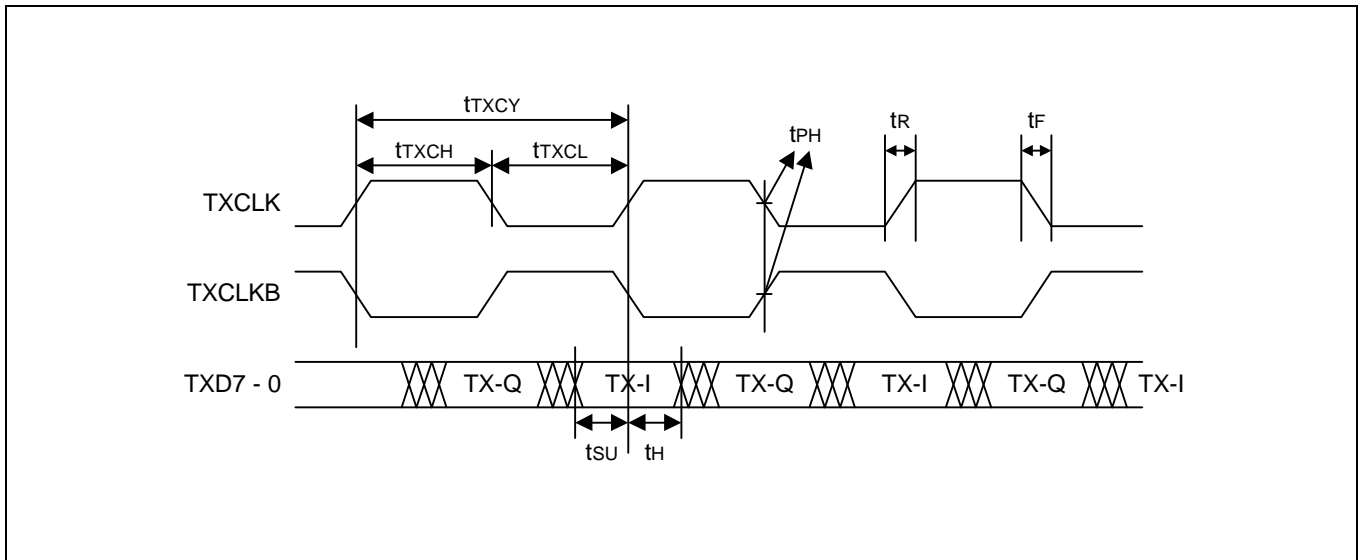

Figure 5. CDMA Transmit DAC Timing

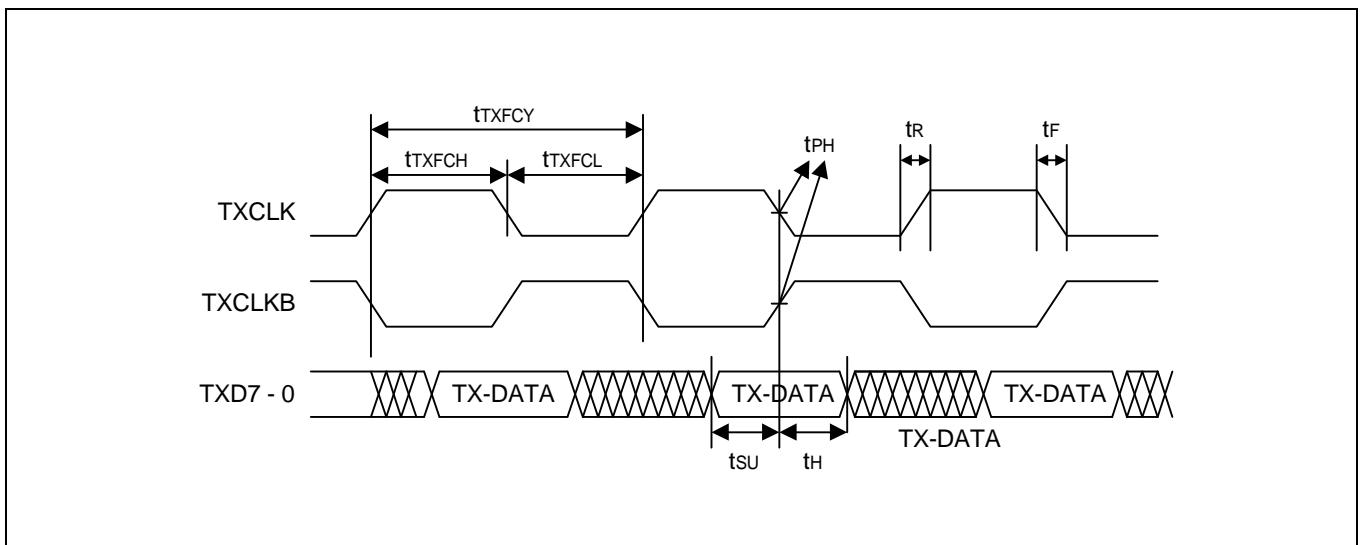

Figure 6. FM Transmit DAC Timing

TIMING DIAGRAM (Continued)

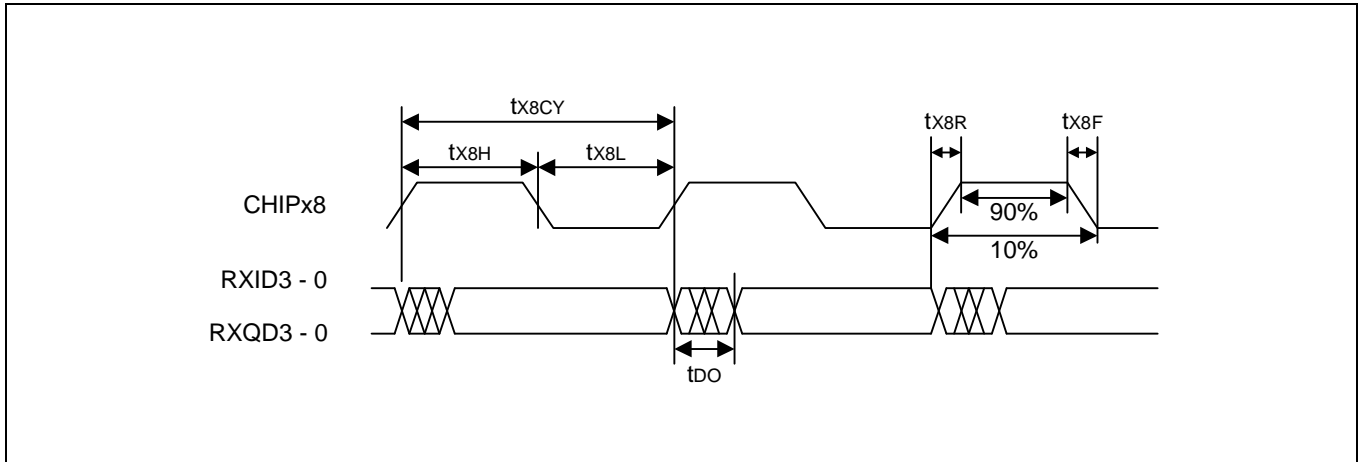

Figure 7. CDMA Receive ADC Timing

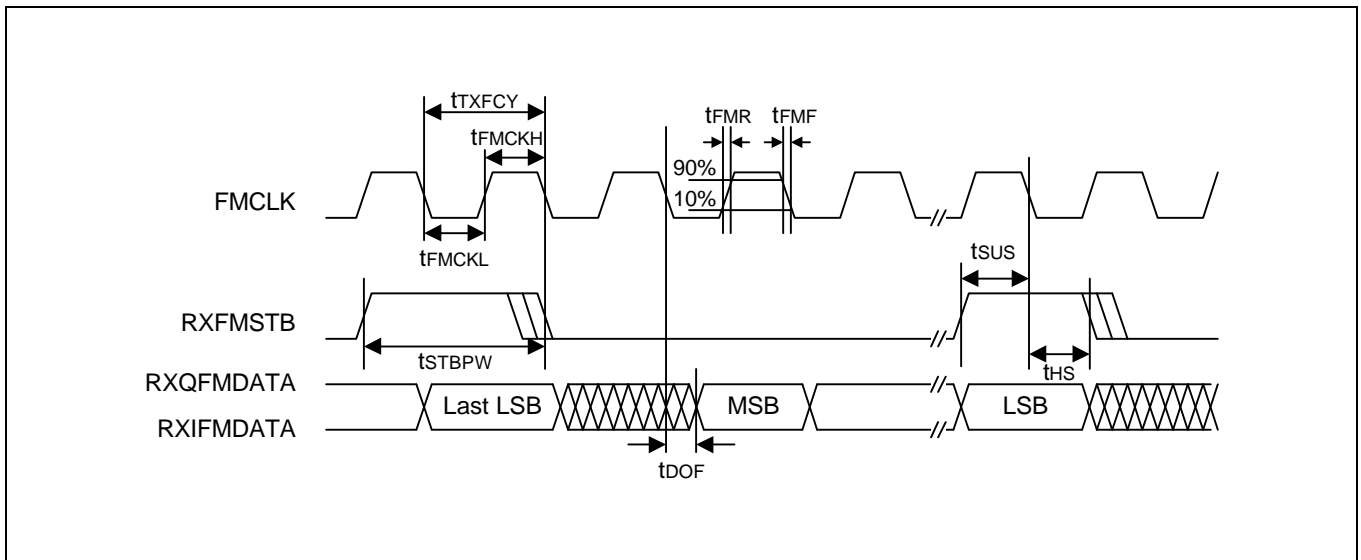

Figure 8. FM Receive ADC Timing

TIMING DIAGRAM (Continued)

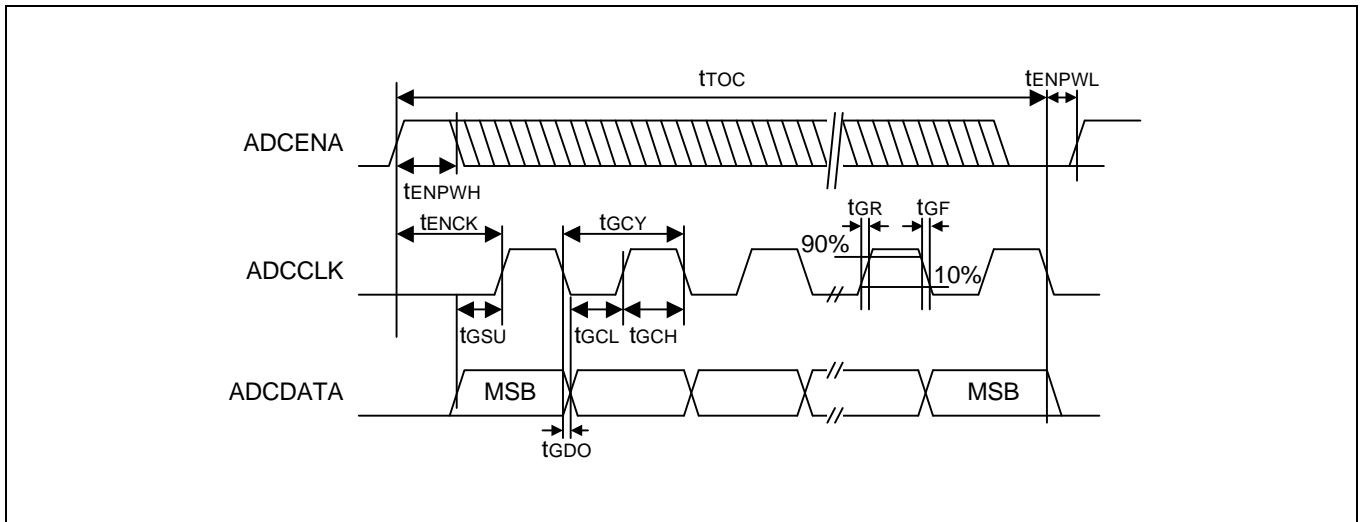

Figure 9. General Purpose ADC Timing

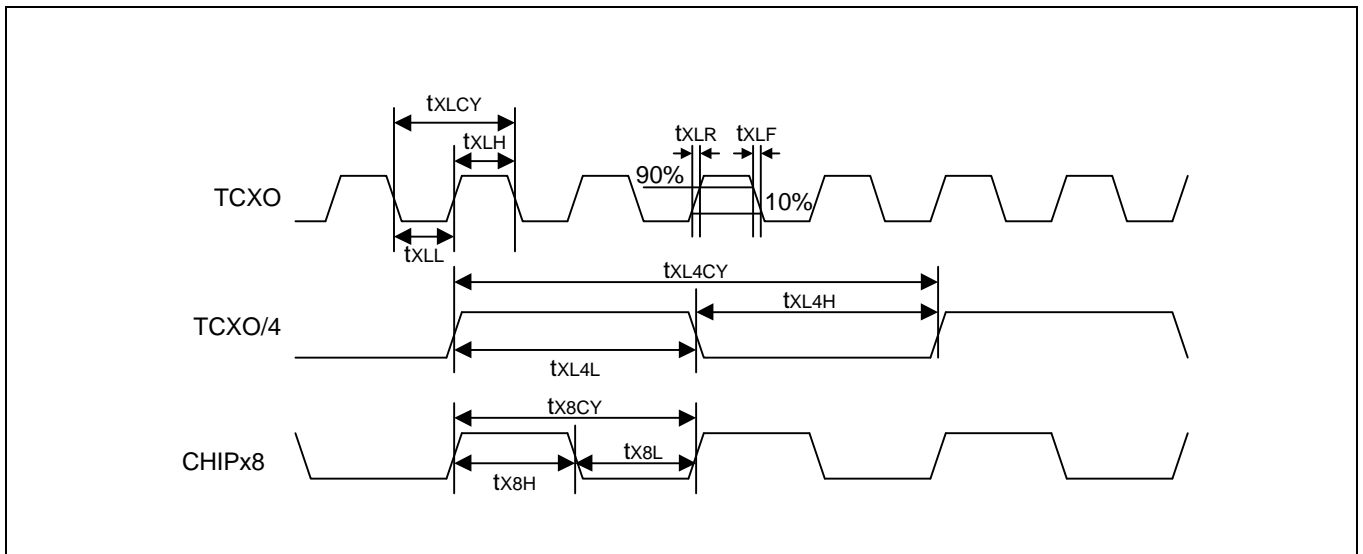

Figure 10. TCXO and CHIPx8 Timing

SYSTEM PERFORMANCE PARAMETERS

CDMA Rx Performance ($V_{CC} = 3.3V$, $T_a = 25^{\circ}C$)

Characteristic	Symbol	Test Conditions	Min.	Typ	Max.	Units
Rx full-path gain	GRX	Overall full path gain	-	38	-	dB
Rx input sensitivity	SENRX	Differential full scale, input level	-	1.8	-	mVrms
Rx input dynamic range (Input desense check)	DYNRX	Need two-tone signal source Check desense level	-	-	1	dB
Maximum available IF frequency	MAXIF	Check ADC output	240	-	-	MHz
Rx output total harmonic distortion (ADC linearity check)	THDRX	Check ADC output	-	-	5	%
Offset Adjust gain	GOFF C	IOFFSET, QOFFSET	210	270	330	% FS/V
Signal path gain variation	GCSCR	with part to part or V_{DD} or Temperature	-2	-	2	dB
Signal path out-of-band frequency attenuation	ATTCR	$\geq 900kHz$	42	60	-	dB
		$\geq 1.2MHz$	48	70	-	dB
Overall full-path in-band ripple	FTCR	1kHz to 630kHz	-1.5	0.4	1.5	dB
Rx filter I.Q Gain mismatch	MGIQCR	1kHz to 615kHz	-	0.4	1.5	dB
I.Q Phase mismatch	MPIQCR	Demodulator(Rx Mixer) Phase mis-match Measure at I-Q filter output for 50kHz	-	-	10	degree

FM Rx Performance ($V_{CC} = 3.3V$, $T_a = 25^{\circ}C$)

Characteristic	Symbol	Test Conditions	Min.	Typ	Max.	Units
FM receive IF input level	VIFI	sinusoidal, differential	-	2	-	mVrms
FM receive IF single tone jammer level	VJSF	$\geq 60kHz$, offset differential	-	300	-	mVpp
Input referred noise	NIRF	I or Q, measured across FM bandwidth	-	35	45	$\mu Vrms$
Spurious Content	SCRF	Sum of harmonic and non-harmonics power measured at A/D outputs. Two in-band tones, each one half of the maximum input signal level	-	-44	-40	dBc

FM Rx Performance ($V_{CC} = 3.3V$, $T_a = 25^\circ C$)

Characteristic	Symbol	Test Conditions	Min.	Typ	Max.	Units
Spurious content related to jammer	SCRFJ	Peak in-band spurious products measured at A/D outputs. Two-tone Jammer, 50mVrms @60kHz offset and 6.5mVrms @122.5kHz offset +0.733mVrms signal @1kHz offset	-	-28	-18.4	dBc
Offset Adjust gain	GOFF	IOFFSET, QOFFSET	210	270	300	%FS/V
Signal path gain variation	GCSFR	With part to part or V_{DD} or Temperature	-	-	± 1.2	dB
Signal path out-of-band frequency attenuation	ATTFR	$\geq 45kHz$	48	63	-	dB
		$\geq 60kHz$	60	70	-	dB
Signal path in-band frequency flatness	FTCR	0.1kHz to 12.2kHz	-	0.6	1.0	dBpp
Group delay deviation	DGFC	0.1kHz to 12.2kHz	-	-	30	μ Spp
Residual sideband suppression	SRFR		28	-	-	dB

CDMA Tx Performance ($V_{CC} = 3.3V$, $T_a = 25^\circ C$)

Characteristic	Symbol	Test Conditions	Min.	Typ	Max.	Units
IF Output amplitude	VTXCT	Requires full scale quad-phase signals.	250	300	380	mVpp
Carrier suppression (Related DC offset)	SCCT	Requires full scale quad-phase signals.	20	32		dBc
Upper side band suppression (Related I-Q Phase/gain mismatch)	USBS	Requires full scale quad-phase signals.	18	25		dBc
Spurious free dynamic range: IF harmonics	SIFCT	Even harmonics.	20			dBc
		Odd harmonics	9.5			dBc
IF SNR, Noise band 1	SNRCT1	For all frequencies from $f_{IF} = \pm 0.1MHz$ to $f_{IF} < \pm 2MHz$ except at IF harmonics	104			dBc/Hz
Output carrier frequency	CODT			130.38		MHz
In-band filter ripple	FTACT	Measured across the CDMA bandwidth			1.5	dBpp
Filter total harmonic distortion	THDFLT				4	%
Signal path out-of-band frequency attenuation	ATTCCR	$\geq 1.2MHz$	-4			dB
		$\geq 10MHz$	-58			dB

FM Tx Performance ($V_{CC} = 3.3V$, $T_a = 25^\circ C$)

Characteristic	Symbol	Test Conditions	Min.	Typ	Max.	Units
IF Output amplitude	VTXFT	Full scale signals. At nominal V_{DD} and room temperature	-	120	-	mVpp
IF SNR, Noise band 1	SNRFT1	For all frequencies from $f_{IF} = \pm 0.1kHz$ to $f_{IF} < \pm 44MHz$. Exclude frequencies within $\pm 100kHz f_{IF}$.	110	-	-	dBc/Hz
IF SNR, Noise band 2	SNRFT2	For all frequencies from $f_{IF} = \pm 44MHz$.	TBD	-	-	dBc/Hz
Output Amplitude variation	VOFT	Part to part, over V_{DD} , temperature	1.6	-	1.6	dB
Spurious free dynamic range: IF harmonics	SIFFT	Even harmonics.	20	12		dBc
		Odd harmonics SFDR is the ratio in dB of the power in a 30kHz band around the harmonics of the f_{IF} to the power in a 30kHz band around f_{IF} .	10	-	-	dBc
FM_MOD output voltage	VFMOD	Full scale. $RL > 10k\Omega$	470	550	630	mVpp
FM_MOD amplitude variation		Part to part, over V_{DD} , temperature and aging.	-	-	15	%
FM_MOD spurious free dynamic range	SFMOD	Two tone inputs, to 120kHz	42	54	-	dB
FM_MOD SNR	SNRFM	Single tone, full scale to 15kHz	87	90	-	dBc/Hz
FM_MOD amplitude flatness	FTAFT	DC to 10kHz	-	0.4	0.6	dBpp

Receive and Transmit VCO Performance ($V_{CC} = 3.3V$, $T_a = 25^{\circ}C$)

Characteristic	Symbol	Test Conditions	Min.	Typ	Max.	Units
TCXO reference input frequency	FTCXO		-	19.68	-	MHz
TCXO input amplitude	VTCXO	AC coupled	0.5	-	2.0	V _{pp}
RXVCO_OUT output frequency range	FRVCO	Depends upon external components	-	-	500	MHz
RXVCO_OUT phase noise	NPRVCO	Measured at RXVCO_OUT. The external tank component have a minimum Q of 20.	-	-100	-	dBc/Hz @100 kHz o.s.
RXVCO_OUT output voltage swing	VRVCO	AC coupled; measured at 170.76MHz.	-20	-	-	dBm
TXVCO output frequency range	FTVCO	Depends upon external components	-	260.76	-	MHz
Lock mode output current	ILOCK	R _{is} =40KOhms	10	16	20	μA
Acquisition mode output current	IACQ	R _{is} =40KOhms	128	160	200	μA
Maximum IOOUT adjustment range	IMIOUT	Using R _{is} to vary nominal output current.	-50	-	+50	%
PD_OUT compliance voltage	VCPD		04	-	V _{DD} -0.4	V
Reference spurious	SREF		-	-	70	dBc
Open loop LO phase noise (VCO/2)	NLO	CDMA mode, TX IF outputs, full scale DC inputs to I and Q. Tank Q > 20	-	-100	-	dBc/Hz @100 kHz o.s.

General Purpose ADC Performance ($V_{CC} = 3.3V$, $T_a = 25^{\circ}C$)

Characteristic	Symbol	Test Conditions	Min.	Typ	Max.	Units
Offset voltage	GOFF	Mid-scale code referred to +1.5Volt	-	± 10	-	mV
Gain error	GERR		-	± 2	-	%
DLE	GDLE		-	0.5	1.25	LSB
ILE	GILE		-	0.5	1.25	LSB

APPLICATION INFORMATION

Receive IF Inputs

The receive IF inputs, RXIF and RXIF, differentially drive an input stage within the S1M8653B, where the input impedance is nominally equal to 500 Ohms. These pins are biased at a DC level of 1.6 Volts and require AC coupling. AC coupling capacitor values should be chosen to maximize the power transfer from receive IF circuitry into the S1M8653B. The internal ground and power rails associated with the receive IF input circuitry are pins 4(GND) and 5 (Vcc) respectively.

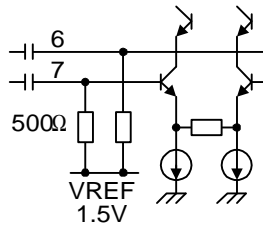

Figure 11.

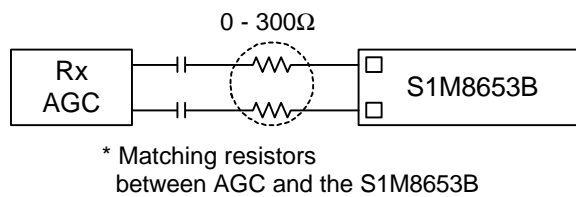

Figure 12.

Transmitting IF Outputs (Use Differential only)

The transmit IF outputs, TXIF and TXIF, are differential emitter-follower outputs with nominal output impedance of 50 ohms. The DC bias on these outputs necessitates AC coupling to the subsequent transmit IF signal path in order to maximize the power transferred from the S1M8653B. The internal ground and power rails associated with the transmit IF output circuitry are pins 13(GND) and 14(V_{DD}), respectively.

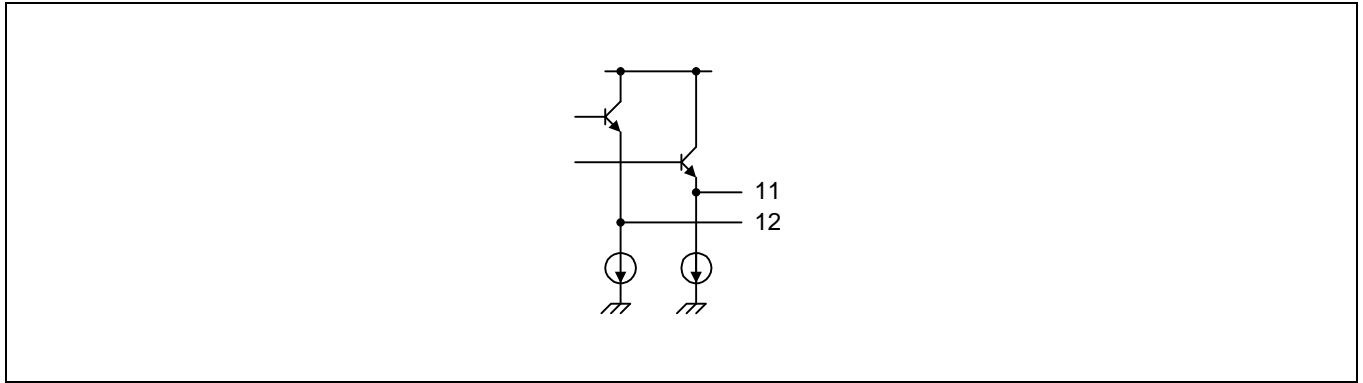

Figure 13.

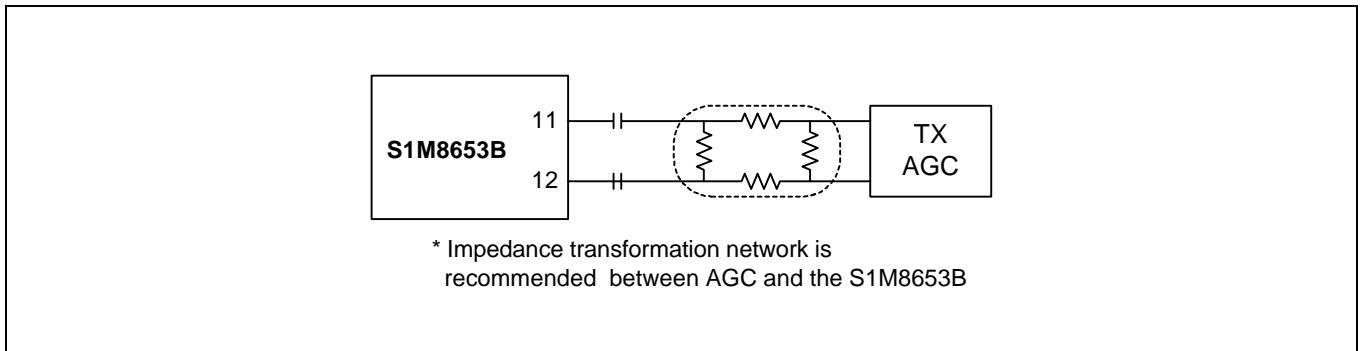

Figure 14.

Rx VCO Output

A single-ended receive VCO signal is output from the RXVCO_OUT(pin 80). The frequency response curve, shown below, indicates that the output signal levels are about -12dBm in cellular band(170.76 MHz) and -12dBm in PCS band(440.76 MHz). The IF input sensitivity of typical PLL for the mobile phone applications range from -25dBm to -30dBm at 450 MHz, well below the receive VCO output levels of the S1M8653B.

The receive VCO circuitry uses two ground pins; one pin is dedicated to the single-ended output drive stage(pin 1) but the other pin(pin 4) is shared by rest of the circuitry. However, a single power pin (pin 5) serves the whole

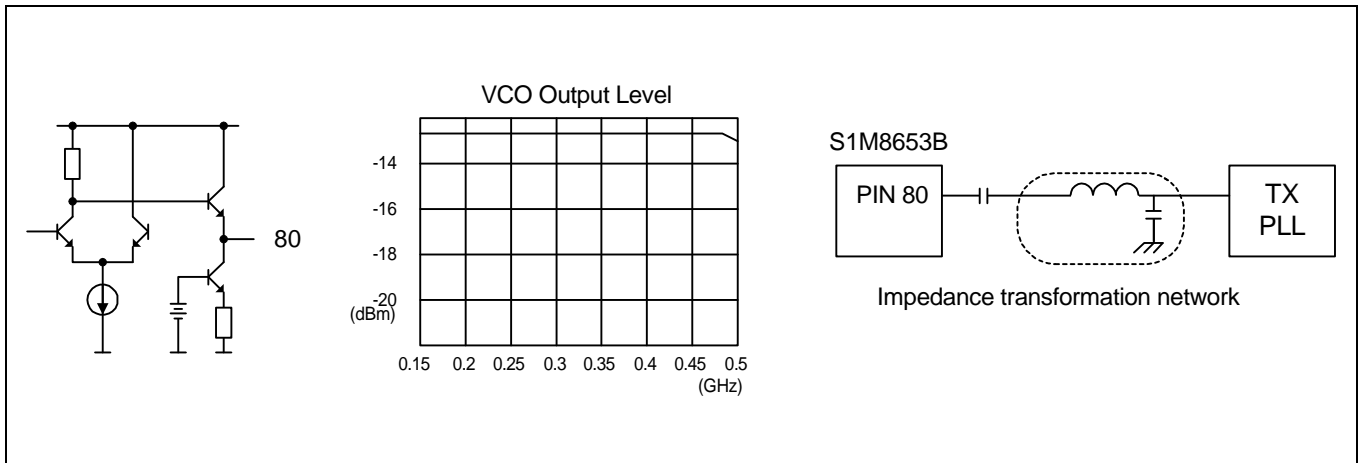

Figure 15. Receive VCO Output Drive Stage

Rx / Tx Tank Circuit

The frequency of oscillation for any LC resonant tank circuit is determined by, where L and C are the equivalent inductance and capacitance, respectively, of the tank circuit and parasitics of the S1M8653B. The parasitic capacitance between the RXVCO_T1 and RXVCO_T2 pins of the S1M8653B has been measured to be about 4 pF. Recommended Q factor of the resonant tank circuit is any value greater than 20.

$$f_0 = \frac{1}{2\pi\sqrt{LC}}$$

The net capacitance of the tank circuit comprises a varactor diode (Ctr2), a scaling capacitor(Ctr1) connected in parallel with the varactors, two DC blocking capacitors(Cd) isolating the DC bias of the varactors from the S1M8653B, and pin-to-pin and pin-to-ground parasitic capacitors (C_{pp}, C_p). The net tank capacitance is found from

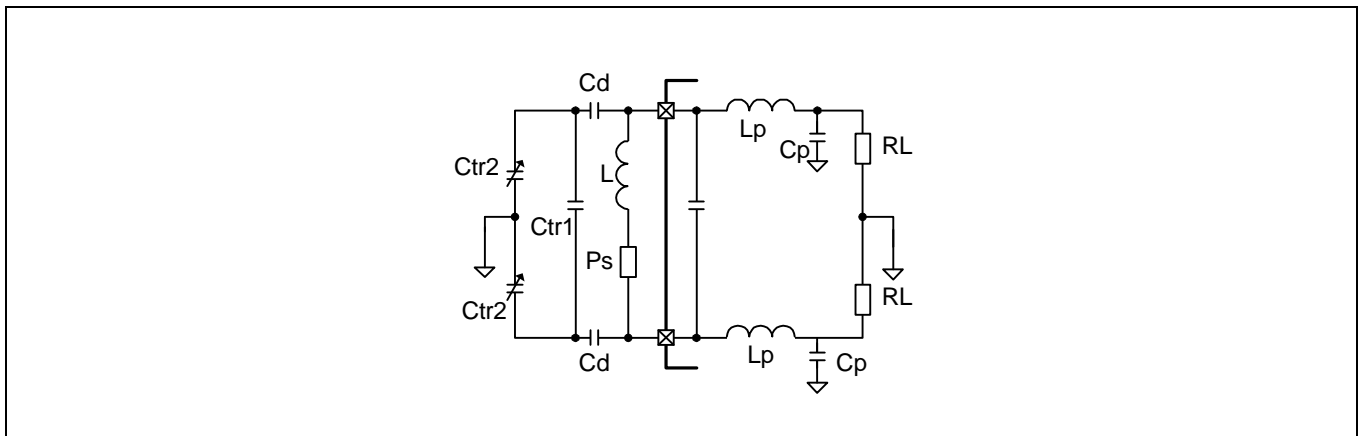

Figure 16. VCO Tank Circuit Diagram

$$C = \frac{(Ctr1 + (Ctr2)/2) * Cd}{(Ctr1 + (Ctr2)/2) * 2 + Cd} + C_{pp} + (C_p)/2$$

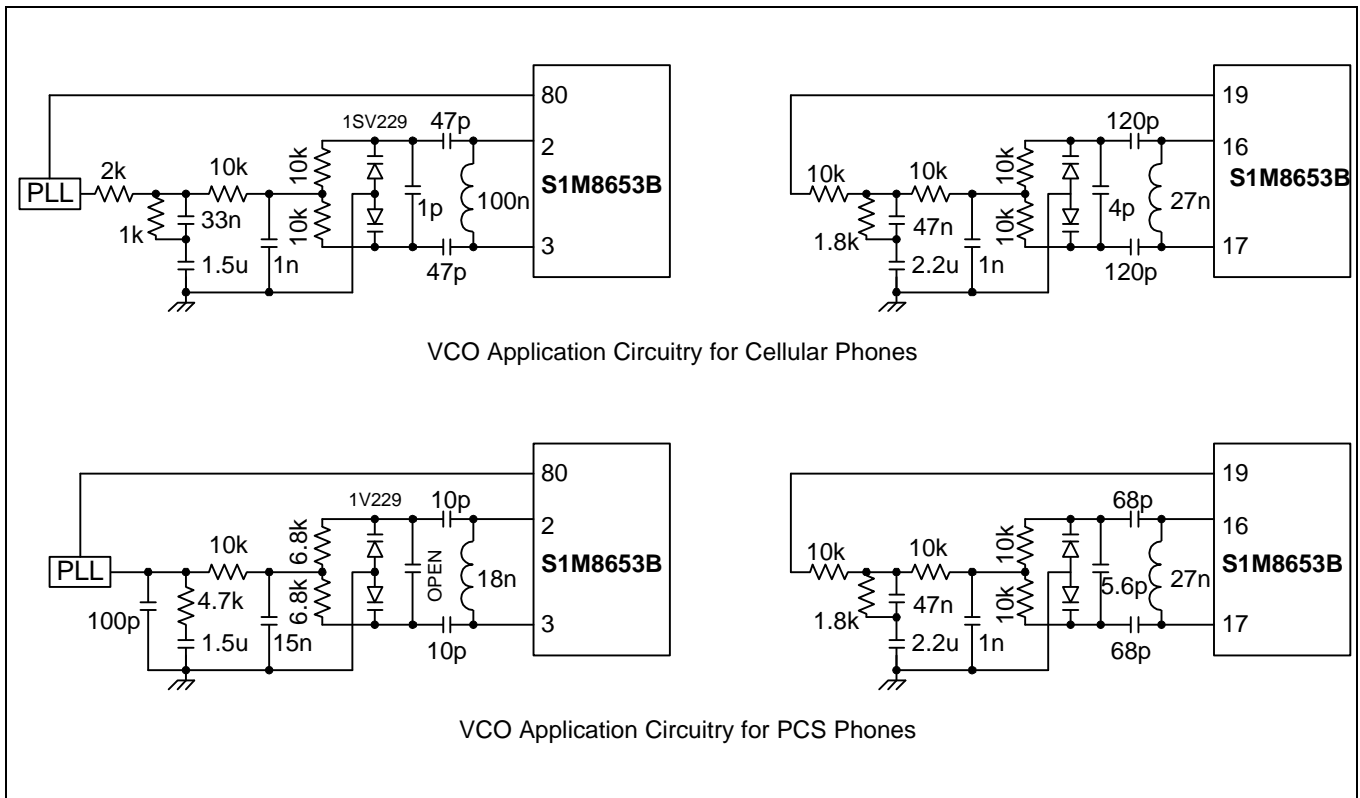

Figure 17. VCO Application Circuitry

PD_OUT Current Setting

The external resistor connected to the PD_ISET determines the level of the charge-pump current sourced by PD_OUT, which affects the band-width of the transmit PLL.

TCXO (Temperature Compensated Crystal Oscillator)

Shown in the table below is the specifications for this oscillator. It must be temperature compensated, and provide a stable and accurate 19.68 MHz signal to the S1M8653B.

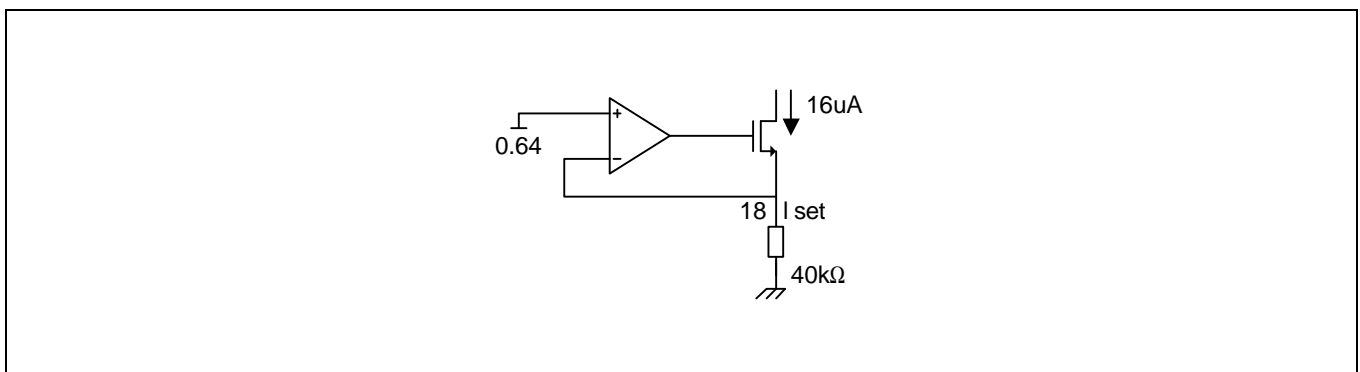

Figure 18.

Table 2. TCXO Requirements

Power supply voltage	3.0V to 3.6V	Frequency deviation	± 0.2ppm
Output level	0.8Vpp min.	Phase noise	-120dBc/Hz@100Hz min.
Nominal frequency	19.68MHz	Frequency control range	235 ± 60Hz
Temperature drift	± 2ppm/°C	Control voltage range	+ 0.5V to 2.5V
Power supply sensitivity	± 0.3ppm/V	Control voltage input impedance	100kΩ min.

Tx PLL Synthesizer

The transmit synthesizer consists of a VCO, a divide-by-two phase splitter, divide by M and N counters, and a phase detector. The VCO and divide-by-two generate the I and Q LO signals(130.38MHz), which are used in up converting analog baseband signals to IF signals. The LOCK signal, when asserted logic low, indicates to the external world, including the MSM, that the transmit PLL is not in lock.

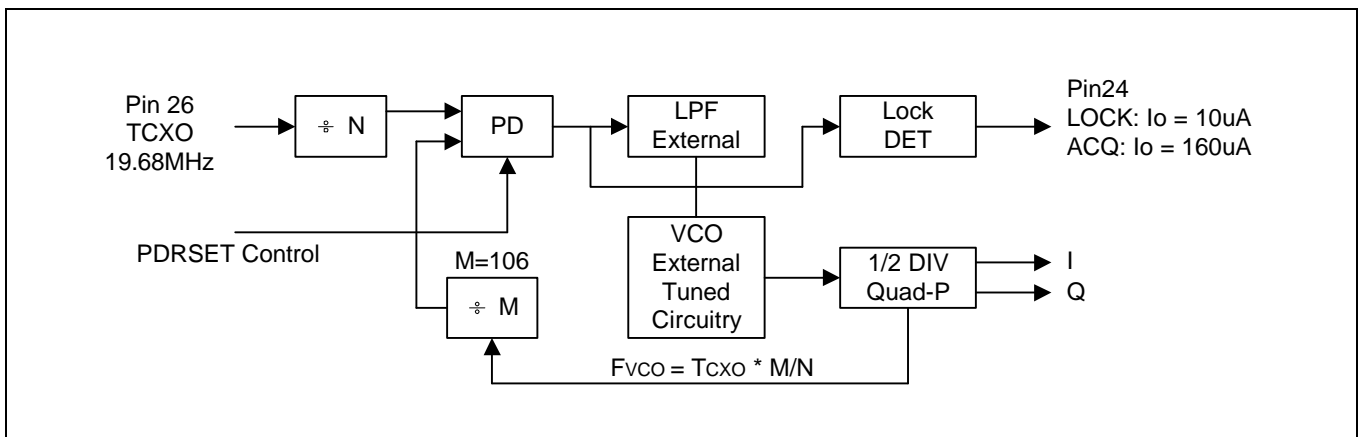

Figure 19. Transmit VCO Synthesizer

I/Q Offset Control

The full path offset sensitivity has been set to 270% FS/V. Please refer to the functional description section of this document for more information on the I/Q offset control.

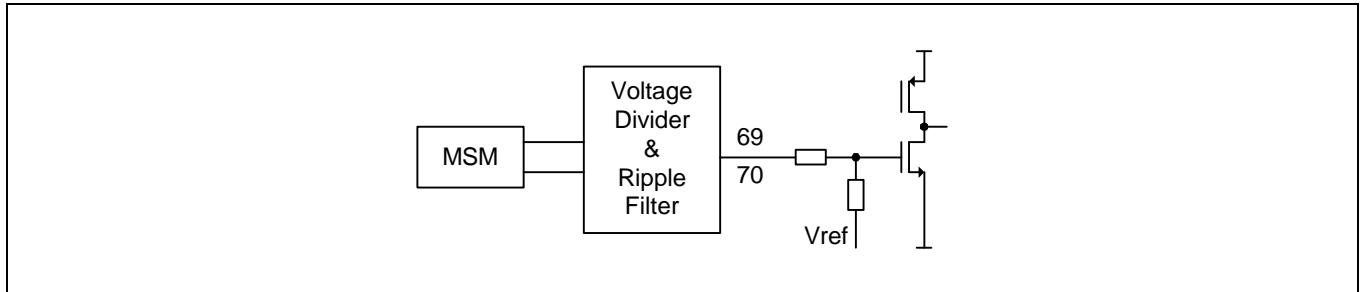

Figure 20.

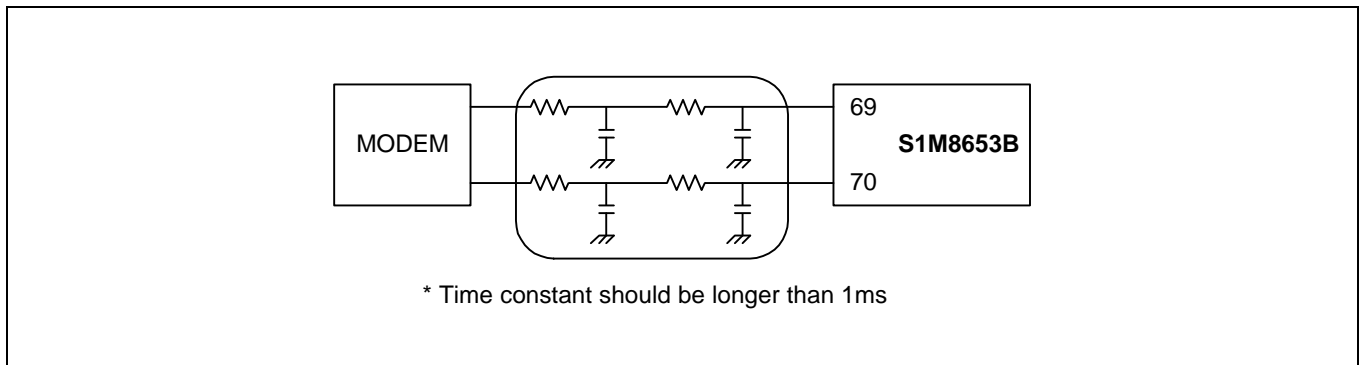

Figure 21.

FM Modulation Scaling

The FM_MOD output is used to frequency modulate the transmit VCO. FM_MOD 's voltage swing is normally 550mVpp to achieve the required frequency deviation of the transmit VCO when the device operate in FM mode. A $\pm 30\text{kHz}$ deviation of transmit VCO frequency is translated into $\pm 15\text{kHz}$ deviation of IF frequency by quad-phase generator (it executes divide-2). A voltage divider can be used as long as the total load on FM_MOD is greater than 10kOhms.

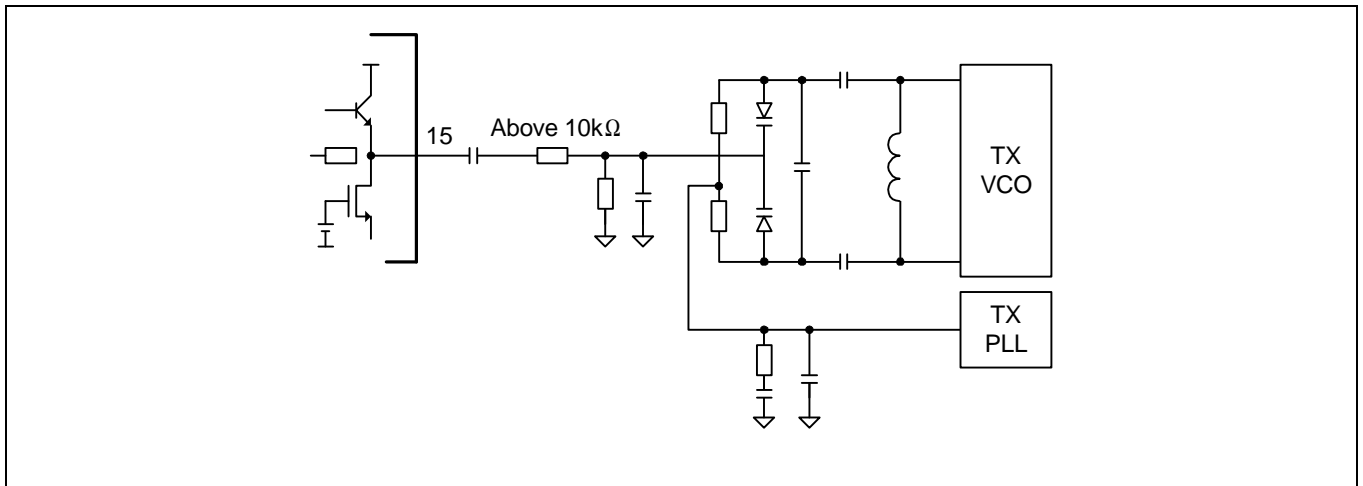

Figure 22. FM Modulation Scaling

ADC and DAC Ranges

Since ADCs and DACs on the S1M8653B have access to internally generated references, no external adjustment or calibrations are required. The GP ADC can be used for various purposes such as monitoring parameters like battery voltage and temperature. For a nominal power of 3.3 Volts the center of the input voltage range is 1.5 Volts; the input voltage, on the other hand, is equal to 2.0 Volts.

Table 3. ADC Output Coding

Input Voltage		Output Data	Input Voltage	Output Data
FM Receive ADC	General Purpose ADC	MSB.....LSB	CDMA Receive ADC	MSB.....LSB
Greater than positive full-scale	> 2.500	1111 1111	Greater than positive full-scale	1111
Positive full-scale	2.500	1111 1111	Positive full-scale	1111
99.6% of full-scale	2.492	1111 1110	93.7% of full-scale	1110
.....
50.2% of full-scale	1.504	1000 0000	53.3% of full-scale	1000
49.8% of full-scale	1.496	0111 1111	46.7% of full scale	0111
.....
0.4% of full-scale	0.508	0000 0001	6.7% of full scale	0001
Negative full-scale	0.500	0000 0000	Negative full-scale	0000
Less than negative full-scale	< 0.500	0000 0000	Less than negative full-scale	0000



Transmit DAC

The two 8-bit transmit DACs contained in the S1M8653B transform digital data from the MSM into analog signals. Each data conversion is made on the rising edge of TCLK and TCLKB signals and output to an internal anti-aliasing filter. The transmit DAC has been implemented using the current segmentation method.

Table 4. Transmit DAC Performance

Characteristics	Values	Test Conditions
DLE	± 1	There Could Be Missing 1 Code
ILE	± 1.25	
Temperature Code Drift	± 2	Codes -30 to + 80°C
Power Supply Code Drift	± 1	Code $V_{DD} = 3.0V$ to $3.6V$

Power Setup Time

A proper operation during the initial power on stage requires reset-ting of internal digital circuits. The reset signal used for this purpose is derived from the rising edge of V_{DD} as it rises up to the full power level. For a proper operation of the S1M8653B, the rise time (T_{set}) of V_{DD} must be less than $700\mu S$.

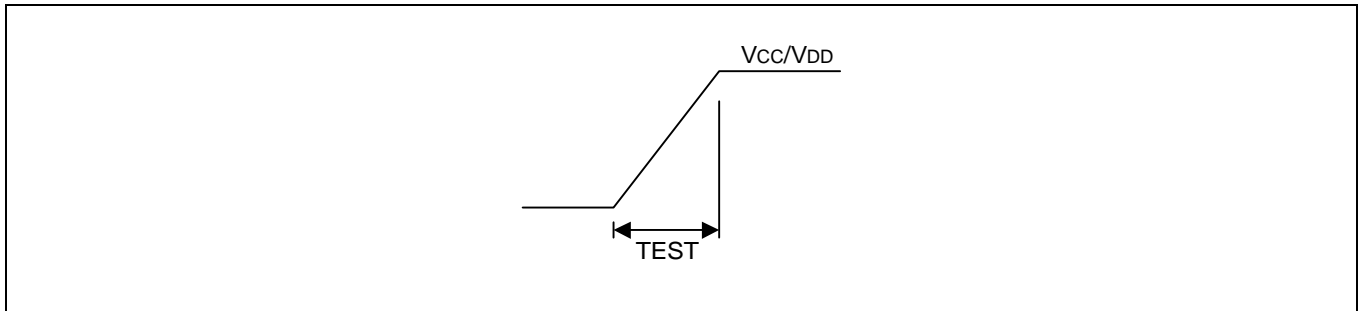

Figure 23.

TEST CIRCUIT

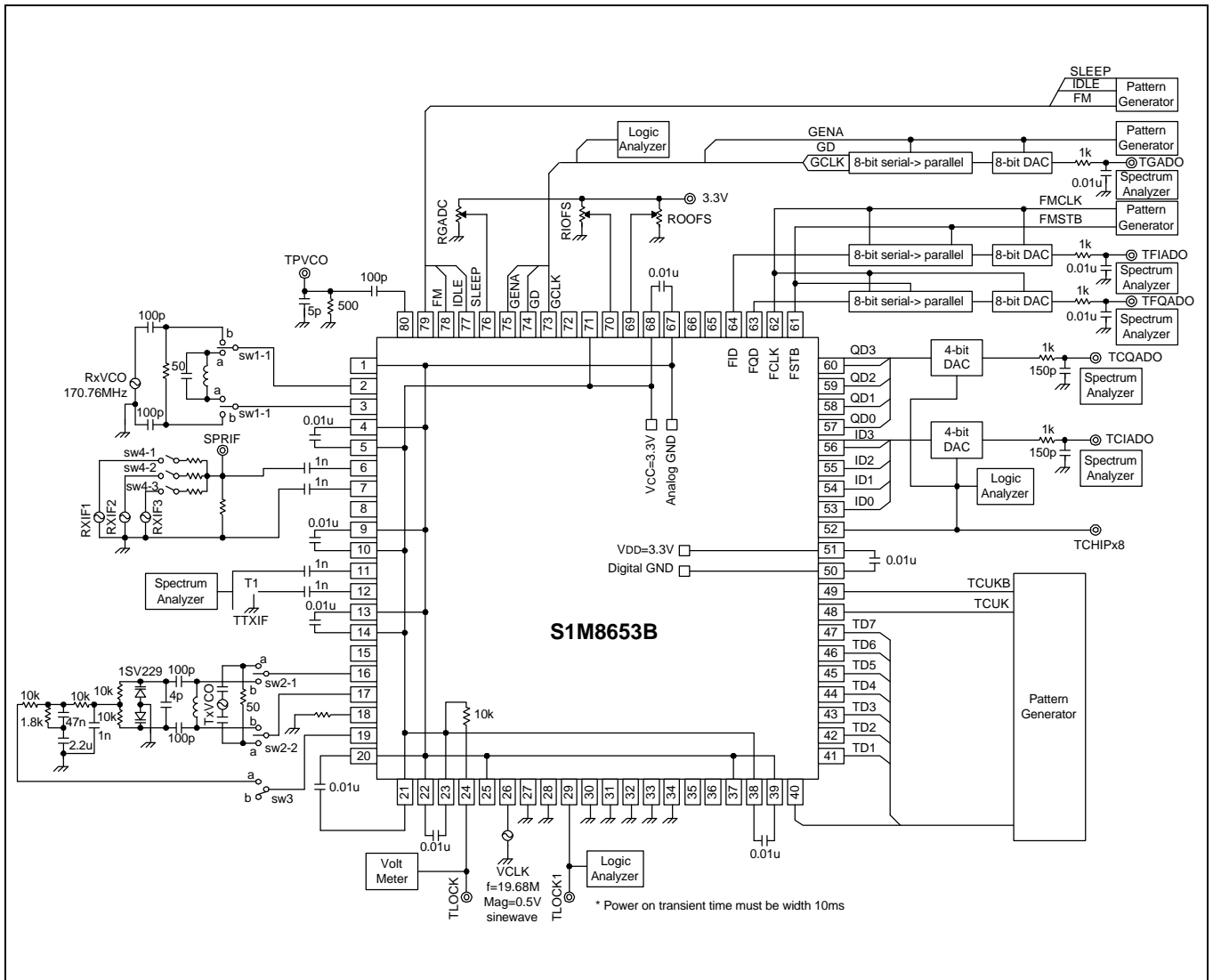
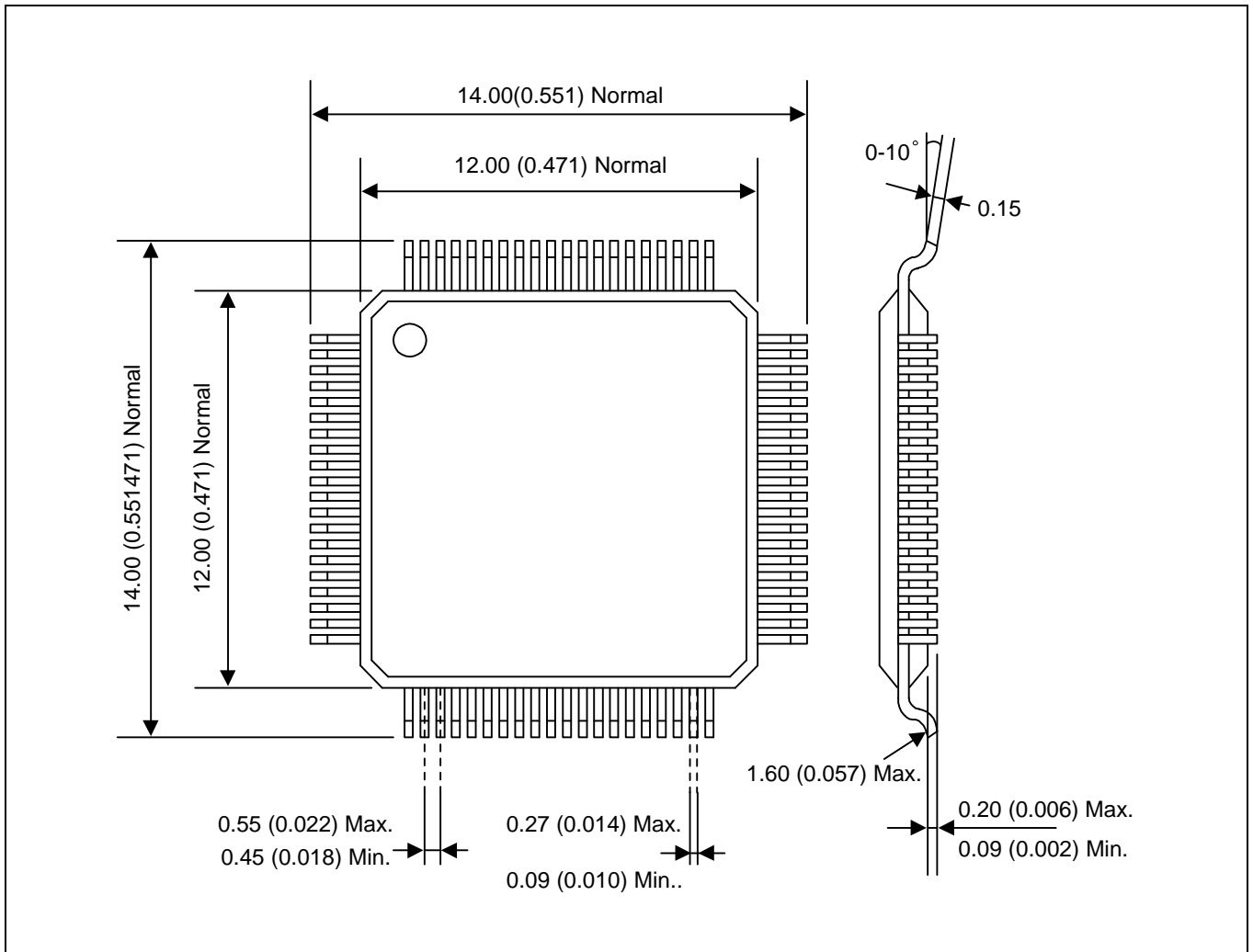

Figure 24. Test Circuit

PACKAGE DIMENSION



NOTES