

**Digitaler Näherungsdetektor mit integriertem Sender Treiber**  
**Digital proximity detector with integrated emitter driver**  
**Lead (Pb) Free Product - RoHS Compliant**

**SFH 7743**

**not for new design in industrial and automotive application (replacement SFH 7741)**



**Wesentliche Merkmale**

- Typ. Arbeitsabstand mit externem Sender SFH 4650: 40 mm
- Optohybrid mit Schmitt-Trigger Ausgang, open drain
- Extrem niedriger Stromverbrauch
- Sehr kleines SMD Gehäuse
- Hohe Umgebungslicht Unterdrückung

**Anwendungen**

- Näherungsdetektor für kurze Entfernungen

**Features**

- Typ. Working distance with external emitter SFH 4650: 40 mm
- Opto hybrid with Schmitt trigger output, open drain
- Extremely low power consumption
- Very small SMD package
- High ambient light suppression

**Applications**

- Short range proximity detector

Typ Type	Bestellnummer Ordering Code
SFH 7743	Q65110A8870

**Grenzwerte**  
**Maximum Ratings**

Bezeichnung Parameter	Symbol Symbol	Wert Value	Einheit Unit
Lagertemperatur Storage temperature	$T_{stg}$	min: - 40 max: + 85	°C
Versorgungsspannung Supply voltage	$V_{dd}$	0 - 6	V
Externe Spannung an Pin External voltage at pin Out Prog Test Anode LED	$V_{out}$	0 - 4.5 0 - 4.5 0 - 4.5 0 - 1.5	V
Sink current durch den Ausgangstransistor Sink current through output transistor (please see figure 1)	$I_{sink}$	10	mA
Treiberstrom <sup>1)</sup> Driver current (for directly connected LED (figure 1a) or transistor base current (figure 1b) page 6)	$I_d$	60	mA
Elektrostatische Entladung Electrostatic discharge - Human Body Model (according to: JESD22-A114E; Class2) - Machine Model (according to: JESD22-A115A; Class B)	<i>ESD</i>	2 200	kV V
latch up protection latch up protection (according to: EIA/JESD78 Class 1)		20	mA

1) Der Treiberstrom  $I_d$  ist abhängig von  $V_{dd}$  und  $R_{prog}$  wie folgt:

The driver current  $I_d$  depends on  $V_{dd}$  and  $R_{prog}$  as in the following formula:

$$I_d = 10\text{mA} + \left( \frac{V_{dd} \times 6}{R_{prog}} \right)$$

### Empfohlene Betriebsbedingungen Recommended Operating Conditions

Bezeichnung Parameter	Symbol Symbol	Wert Value			Einheit Unit
		min.	typ.	max.	
Betriebstemperatur Operating temperature	$T_{op}$	- 20		+ 85	°C
Versorgungsspannung Supply voltage	$V_{dd}$	2.4		3.6	V
Ausgangsspannung Output voltage (please see figure 1)	$DV_{dd}$	1.7		3.6	V
Rauschen der Versorgungsspannung <sup>1)</sup> Supply voltage ripple frequency range 0...20kHz	$dV_{dd}$			200	mV
Pull-up Widerstand Pull-up resistor (please see figure 1)	$R_{pull-up}$	10		1000	kΩ
Abblock Kondensatoren Bypass capacitors (please see figure 1)	$C_{bypass}$ - stabilisation - HF		>1 10 - 100		μF nF
Max. Umgebungslicht Max. ambient light Normlicht / Standard light A	$E_V$ $V_{dd} < 3V$ $V_{dd} > 3V$		1000 2000		lux

<sup>1)</sup> Der externe Sender kann durch den SFH 7743 direkt mit 10mA bis 60mA gepulst betrieben werden; das bedeutet, dass jeder Widerstand in Serie zu  $V_{dd}$  einen Spannungsabfall in der Versorgungsleitung verursacht. Es wird empfohlen, diesen Serienwiderstand so klein zu halten, dass max  $dV_{dd}$  nicht überschritten und min  $V_{dd}$  nicht unterschritten wird. Beim Betrieb des SFH 7743 im Labor ist vom Einsatz geregelter Spannungsversorgungen abzusehen. Durch das Einschalten der IRED wird die Quelle kurzzeitig belastet. Diese Belastung kann zu Spannungsschwankungen der Quelle führen, die wiederum die Funktion des SFH 7743 beeinträchtigen können. Im Normalbetrieb (Akku, Batterie, stabilisierte Netzteile) tritt dieser Effekt nicht auf.

The external emitter can be driven directly with 10 mA to 60 mA in pulsed mode; this means, that any series resistance on the  $V_{dd}$  line causes a voltage drop at the power pin. It is recommended to keep the series resistance low, so that max  $dV_{dd}$  is not exceeded. When testing the SFH 7743 sensor in the lab, please do not use regulated voltage supplies. The IR emitter pulse is a high, short load for the power supply. This load can influence the stability of the output voltage; this instability will influence the operation of the SFH 7743. This effect does not occur during normal operation of the sensor with batteries, storage batteries, or stabilized voltage supplies.

Kennwerte ( $T_a = 25^\circ\text{C}$ )

## Characteristics

Bezeichnung Parameter	Symbol Symbol	Wert Value			Einheit Unit
		min.	typ.	max.	
Minimale Betriebsspannung für Startphase Minimum required supply voltage for start-up (please see figure 2)	$V_{dd, start}$	0.8		2.0	V
Länge der Startphase Start-up time (please see figure 2)	$t_{start}$	60	90	120	ms
Mess-Wiederholzeit Measurement refresh time (please see figure 3)	$t_{refresh}$	60	90	120	ms
LED „An“ Zeit LED „ON“ Time (please see figure 3)	$t_{pulse}$	30	45	60	$\mu\text{s}$
Minimal notwendige Bestrahlungsstärke um den Ausgang von „Low“ --> „High“ zu schalten Minimum necessary irradiation level to switch the output from „Low“ --> „High“	$E_e$			145	$\mu\text{W}/\text{cm}^2$
Schaltabstand mit externem Sender SFH 4650 Operating distance with external emitter SFH 4650 ( $R_{prog} = 470 \Omega$ , $V_{dd} = 3V$ , KODAK White Paper R=90%) (please see figure 1a, Option 1)	$d$		40		mm
Schaltabstand mit externem Sender SFH 4650 Operating distance with external emitter SFH 4650 (SFH 4650 driven with 1A via external transistor, KODAK White Paper R=90%) (please see figure 1b, Option 2)	$d$		150		mm
Durchschnittliche Stromaufnahme <sup>1)</sup> Mean current consumption <sup>1)</sup> ( $R_{prog} = \infty$ , $V_{dd} = 3V$ )	$I_{dd, mean}$		25	50	$\mu\text{A}$
Maximale Stromaufnahme Maximum current consumption ( $R_{prog} = \infty$ , $V_{dd} = 3V$ )	$I_{dd, max}$		10	20	mA

**Kennwerte** ( $T_a = 25^\circ\text{C}$ )**Characteristics**

Bezeichnung Parameter	Symbol Symbol	Wert Value			Einheit Unit
		min.	typ.	max.	
Durchschnittliche Stromaufnahme <sup>1)</sup> Mean current consumption <sup>1)</sup> ( $R_{\text{Prog}} = 470 \Omega$ , $V_{\text{dd}} = 3\text{V}$ )	$I_{\text{dd, mean}}$		45	75	$\mu\text{A}$
Maximale Stromaufnahme Maximum current consumption ( $R_{\text{Prog}} = 470 \Omega$ , $V_{\text{dd}} = 3\text{V}$ )	$I_{\text{dd, max}}$		50	65	mA
Ausgangsleckstrom „high“ Output leakage current „high“ $DV_{\text{dd}} = 2.2\text{V}$	$I_{\text{out, H}}$		5	400	nA
Ausgangsspannung „low“ Output voltage „low“ $DV_{\text{dd}} = 2.2\text{V}$ ; $R_{\text{pullup}} = 270 \Omega$	$V_{\text{out, L}}$		0.1	0.5	V
Wellenlänge der max. Fotoempfindlichkeit Wavelength of max. sensitivity	$\lambda_{\text{S, max}}$		880		nm
Spektraler Bereich der Fotoempfindlichkeit $S = 10\%$ von $S_{\text{max}}$ Spectral range of sensitivity $S = 10\%$ of $S_{\text{max}}$	$\lambda$	730		1080	nm

<sup>1)</sup> gepulster Betrieb: Dauer LED an:  $\sim 44\mu\text{s}$  / Dauer LED aus:  $\sim 90\text{ms}$   
 pulsed operating mode: LED on time:  $\sim 44\mu\text{s}$  / LED off time:  $\sim 90\text{ms}$

Blockdiagramm (empfohlener Pull-Up-Widerstand  $R_{pull\ up} = 10k\Omega \dots 1M\Omega$ )

Block diagram (recommended Pull up resistance  $R_{pull\ up} = 10k\Omega \dots 1M\Omega$ )

**Figure 1a** Blockdiagramm Option 1  
Block diagram option 1

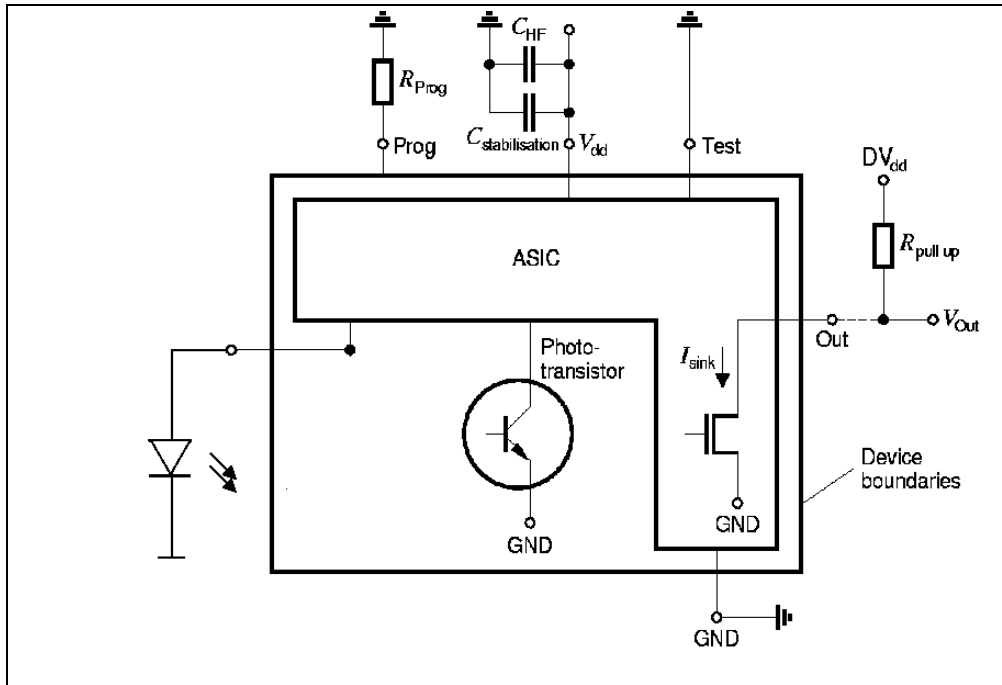

**Figure 1b** Blockdiagramm Option 2  
Block diagram option 2

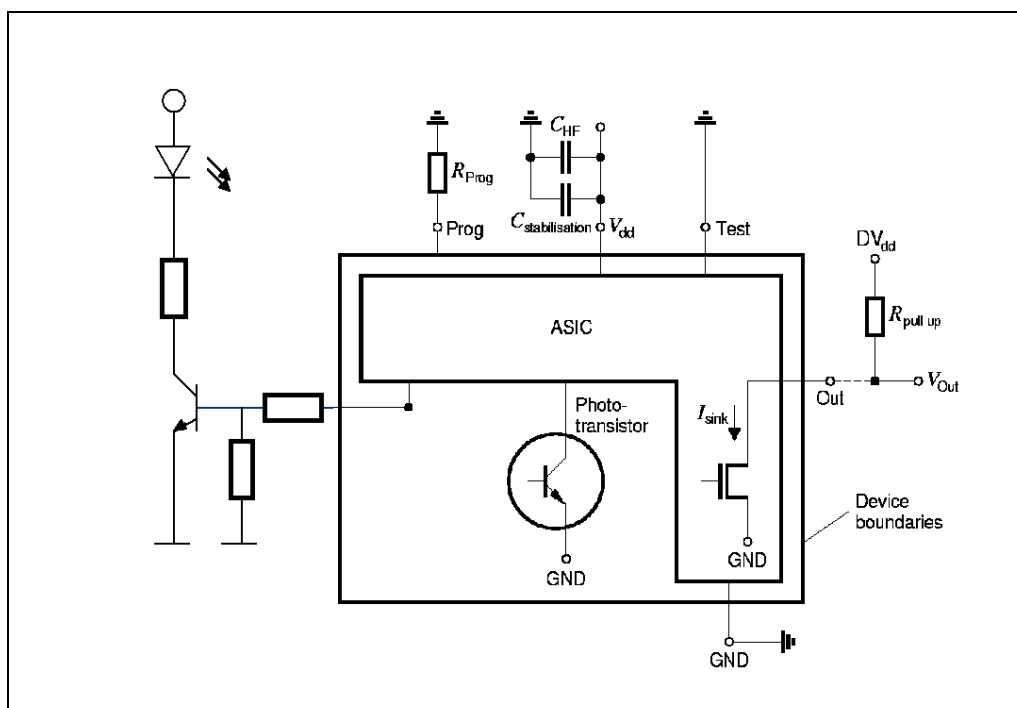

**Figure 2 Startverhalten  
Start-up sequence**

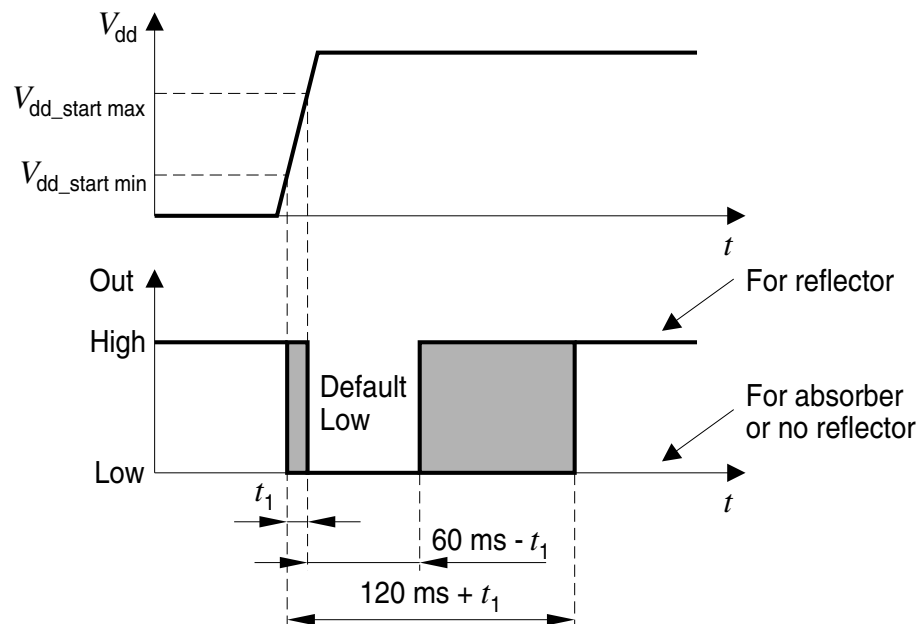

Undefined high or low output impedance

OHF03836

Der Ausgang ist immer hochohmig, wenn an  $V_{dd}$  keine Spannung angeschlossen ist. Wenn die Versorgungsspannung  $V_{dd\_start}$  erreicht, bleibt der Ausgang für  $60\ ms < t_{start} < 120\ ms$  auf „low“. Anschließend findet etwa alle 90ms eine Messung des reflektierten Signals statt und der Ausgang wird entsprechend geschaltet (Figure 3).

If the supply voltage at  $V_{dd}$  is not connected, the output is always high ohmic. When supply voltage reaches  $V_{dd\_start}$ , the sensor output stays low for  $60\ ms < t_{start} < 120\ ms$ . Subsequently approx. every 90ms the reflected signal is measured and the output is set accordingly (Figure 3).

**Figure 3 Timing diagram**

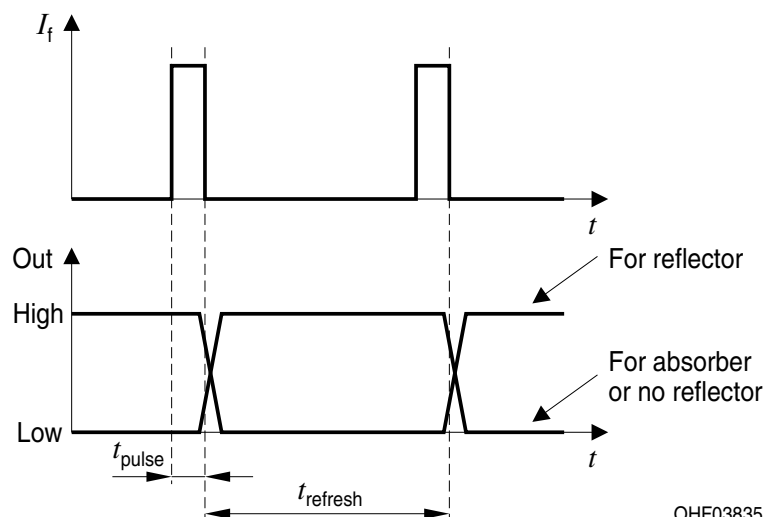

OHF03835

**Phototransistor**  
**Relative Spectral Sensitivity**

$S_{rel} = f(\lambda); T_A = 25^\circ\text{C}$

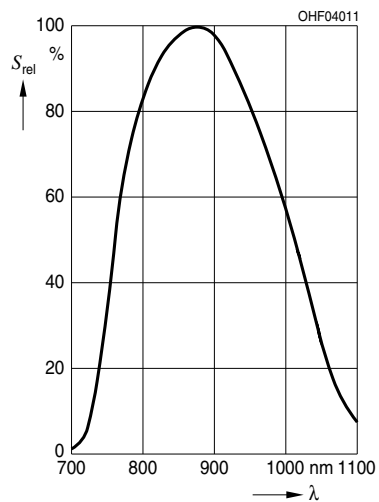

**SFH 7743:**  
**Mean current consumption**

$I_{dd} = f(V_{dd}); R_{prog}; T_A = 25^\circ\text{C}$

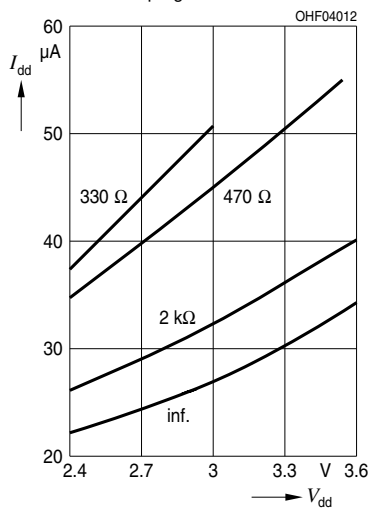

Maßzeichnung  
Package Outlines

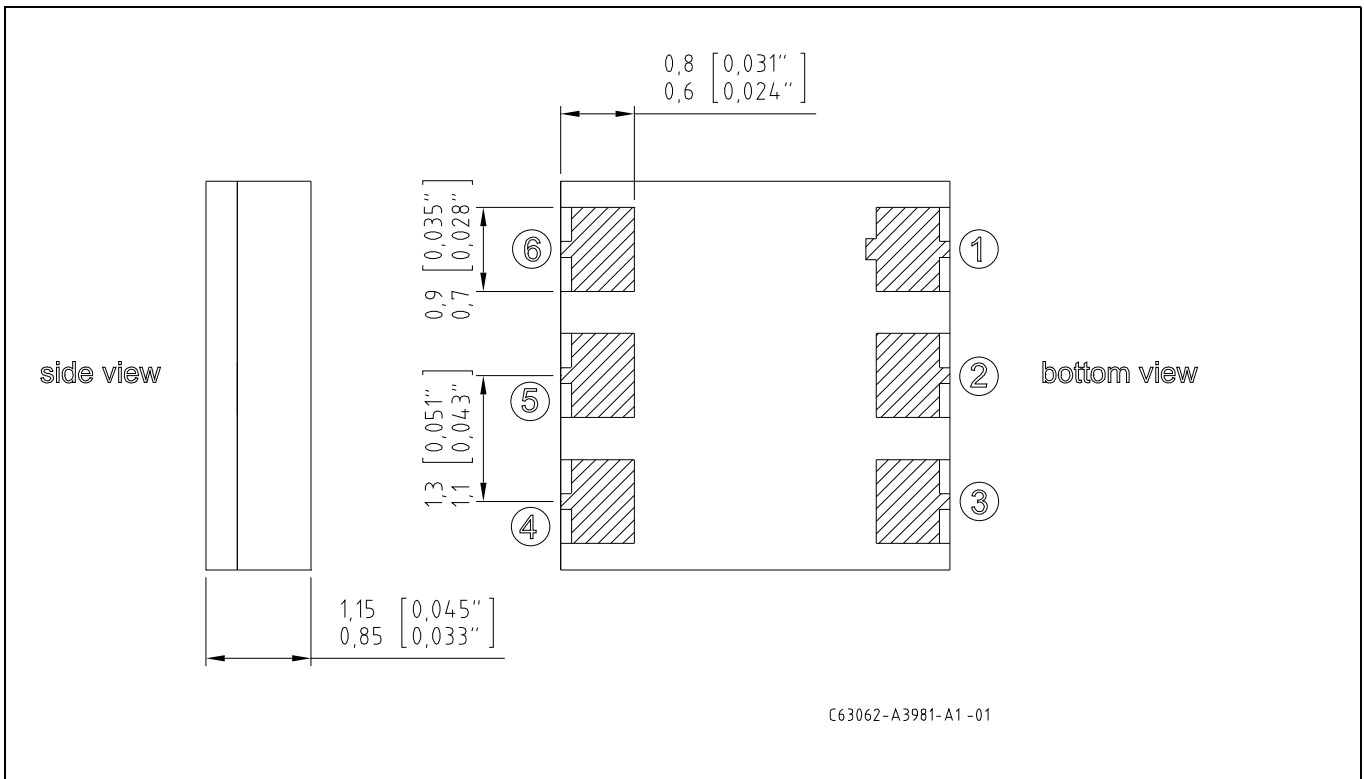
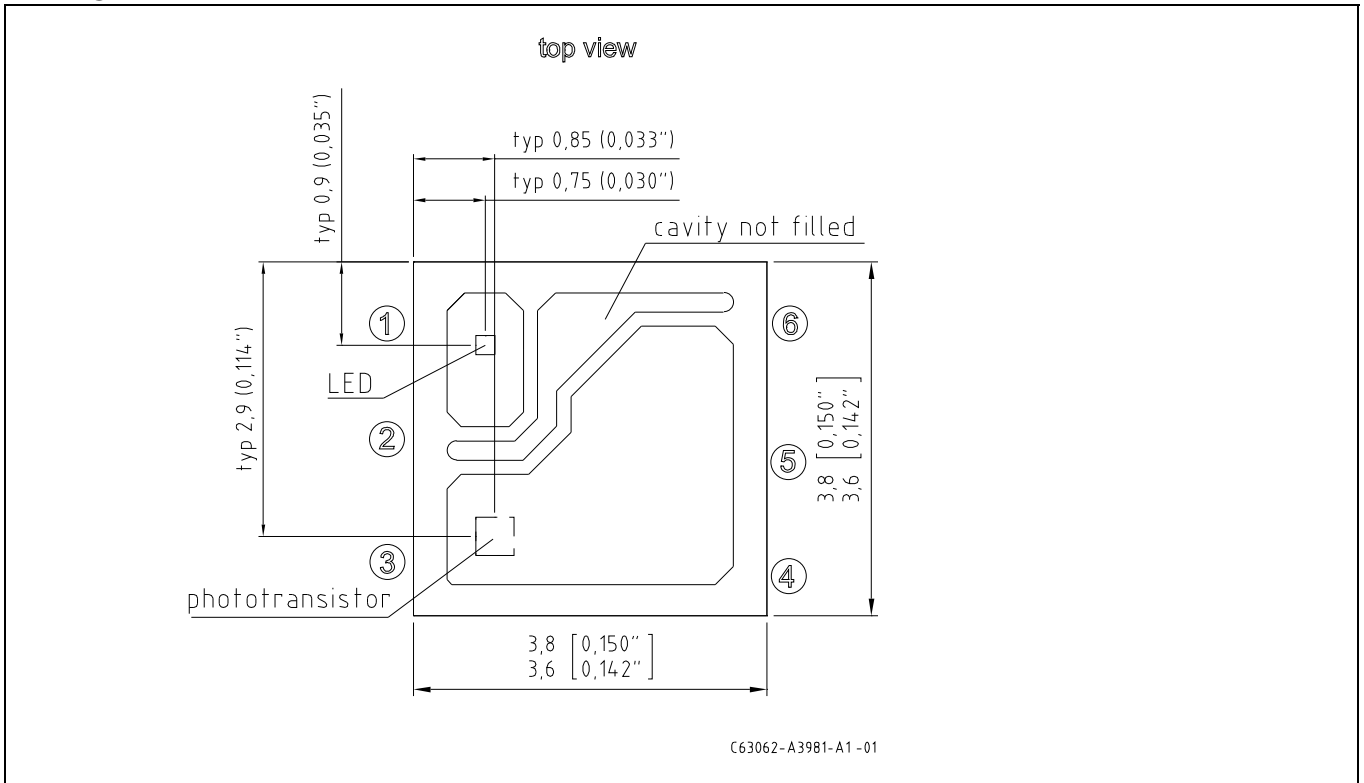

Maße in mm (inch) / Dimensions in mm (inch)

## Anschlußbelegung Pin configuration

Pin #	Description
1	external LED (anode pin) or $I_d$ for driver circuit
2	GND
3	Out
4	Test (must be connected to GND)
5	$V_{dd}$
6	Prog

## Bauteilaufnahme device pickup

Vakuum Pipette sollte das Bauteil am rechteckigen Außenrahmen fassen.

Laminar vacuum pickup nozzle should use the rectangular outer wall of the device for handling.

## Empfohlene Pipette Recommended pickup nozzle

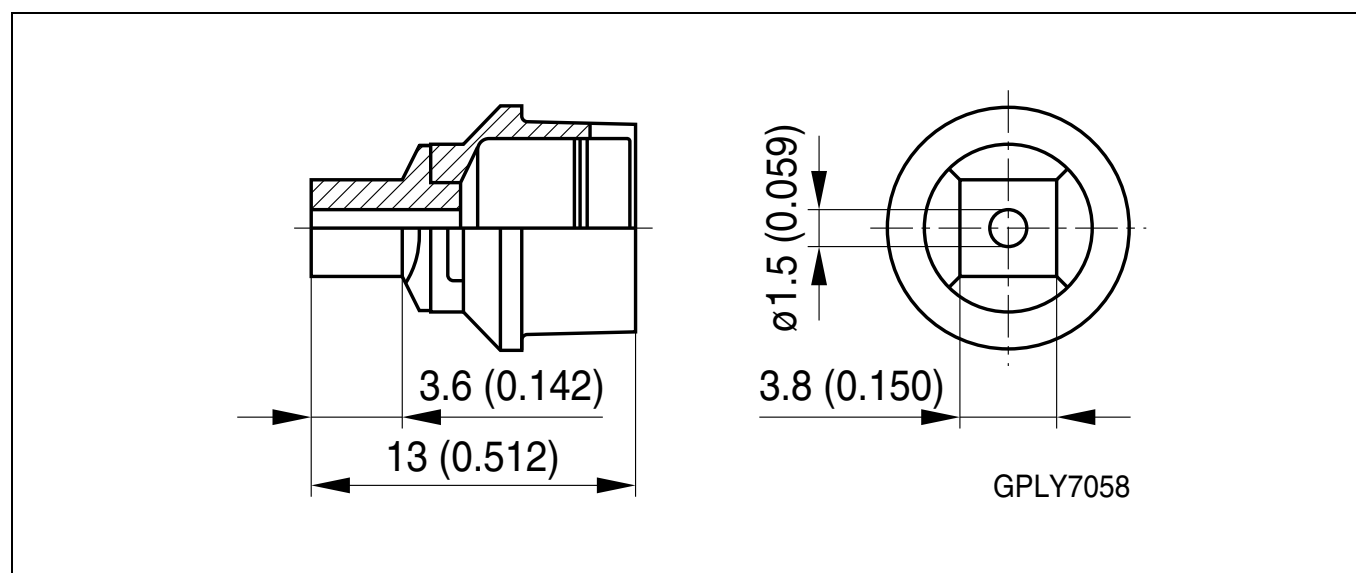

Maße in mm/ Dimensions in mm

**Empfohlenes Lötpaddesign**  
**Recommended Solderpad Design**

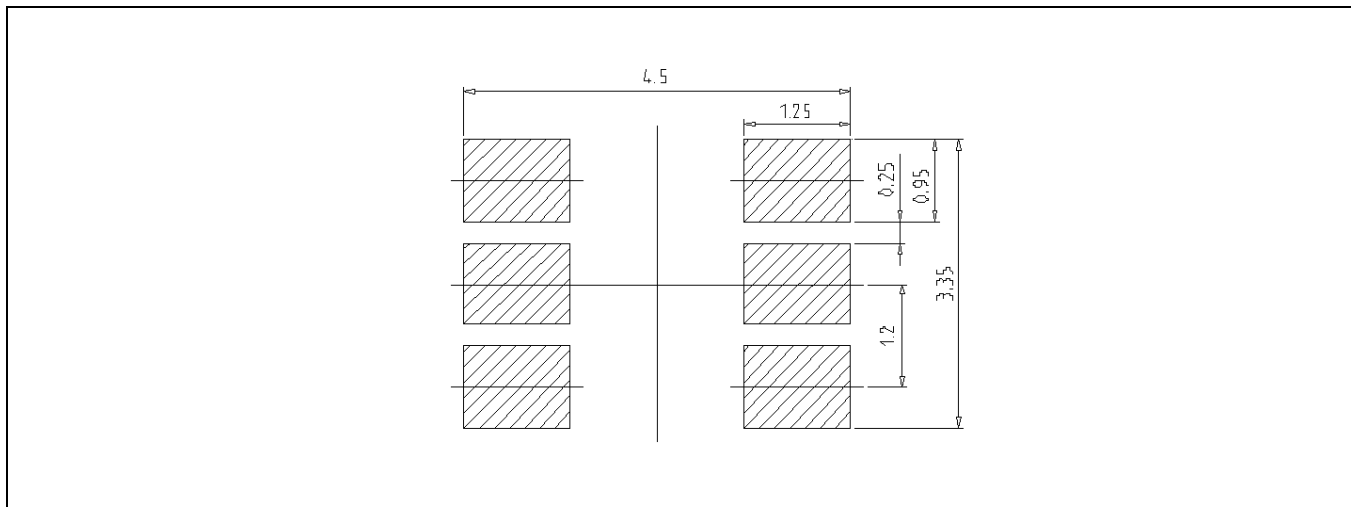

Maße in mm / Dimensions in mm

**Gurtverpackung**  
**Taping**

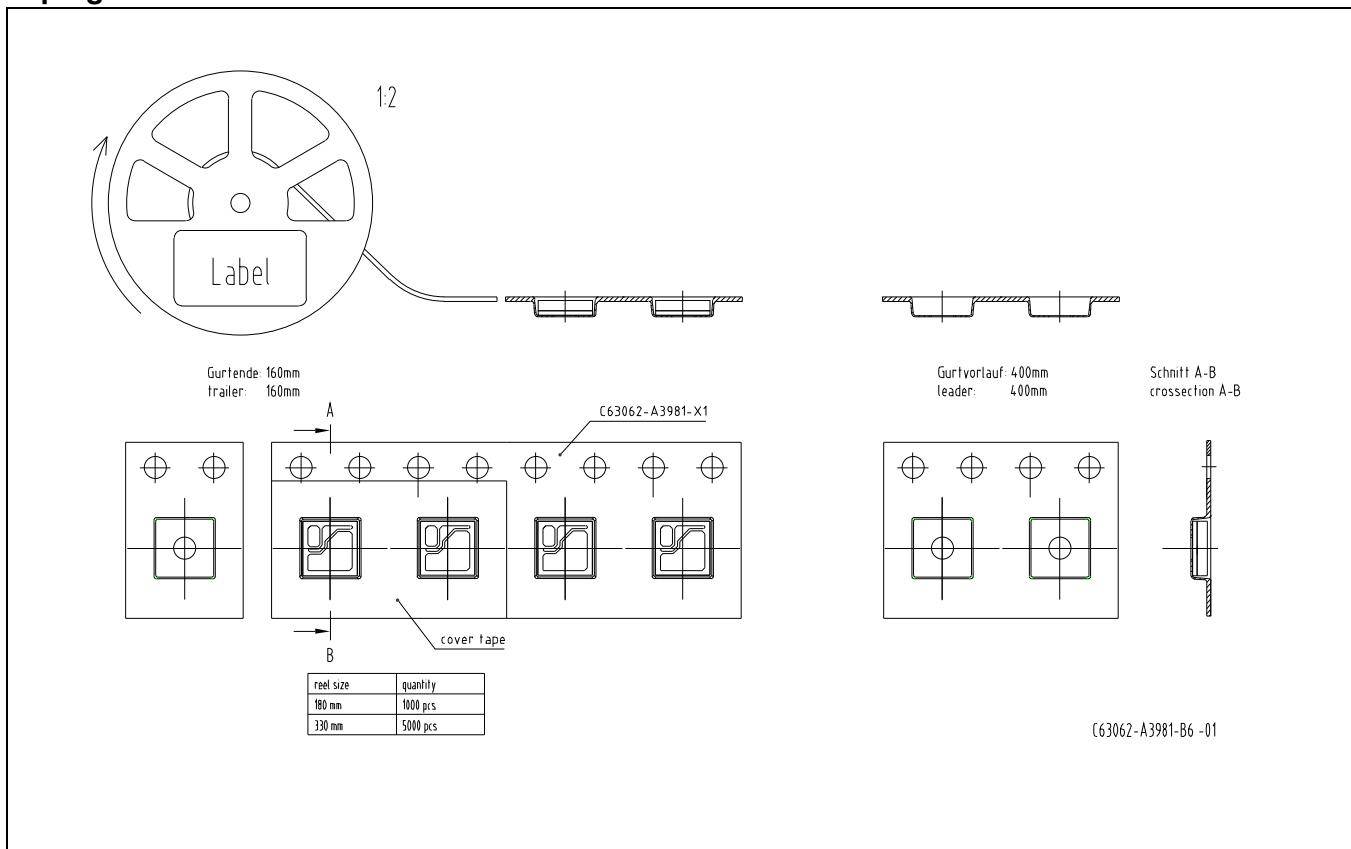

Maße in mm / Dimensions in mm

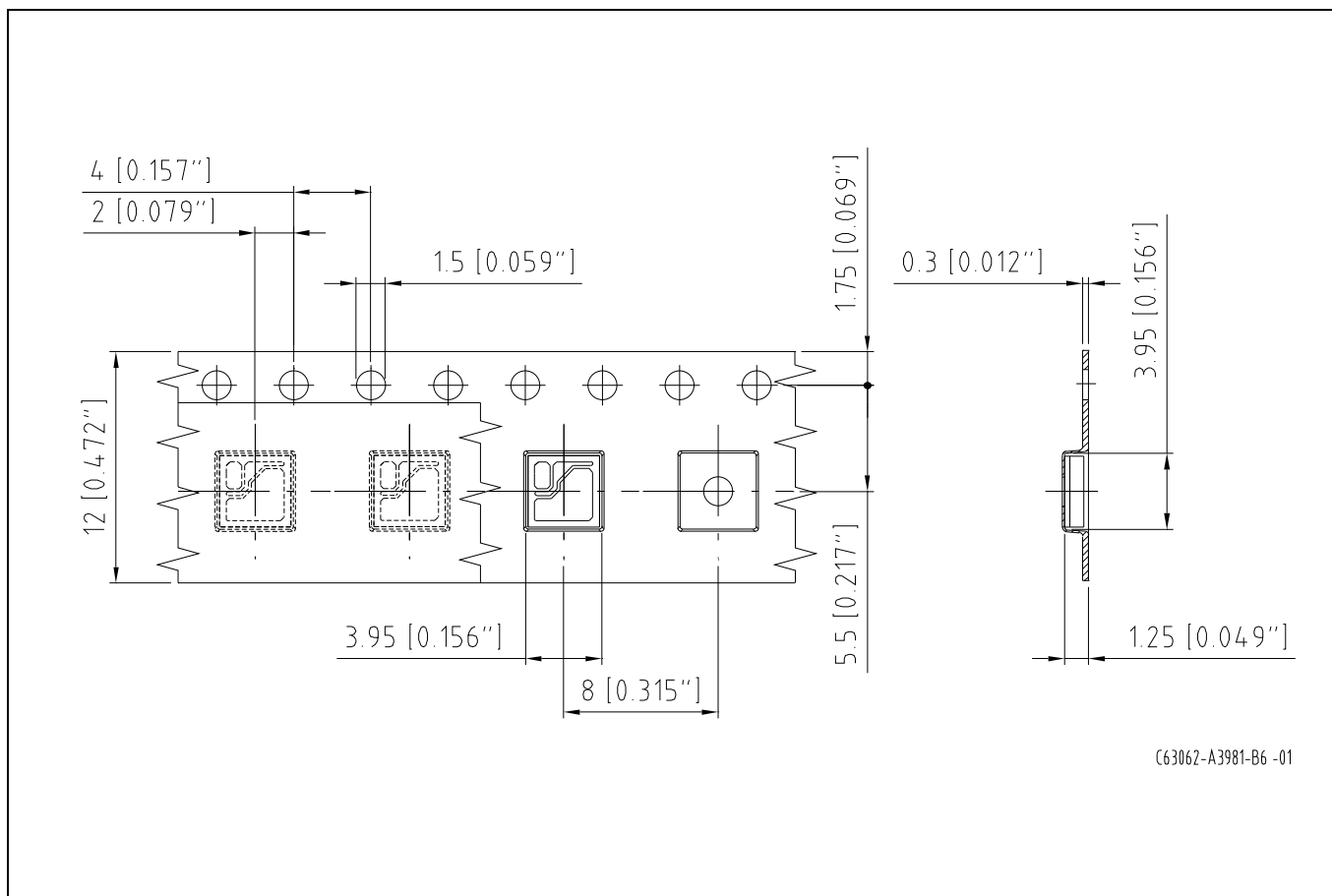

Maße in mm / Dimensions in mm

**Lötbedingungen**  
**Soldering Conditions**

**Reflow Lötprofil für bleifreies Löten**  
**Reflow Soldering Profile for lead free soldering**

Vorbehandlung nach JEDEC Level 4  
Preconditioning acc. to JEDEC Level 4  
(nach J-STD-020C)  
(acc. to J-STD-020C)

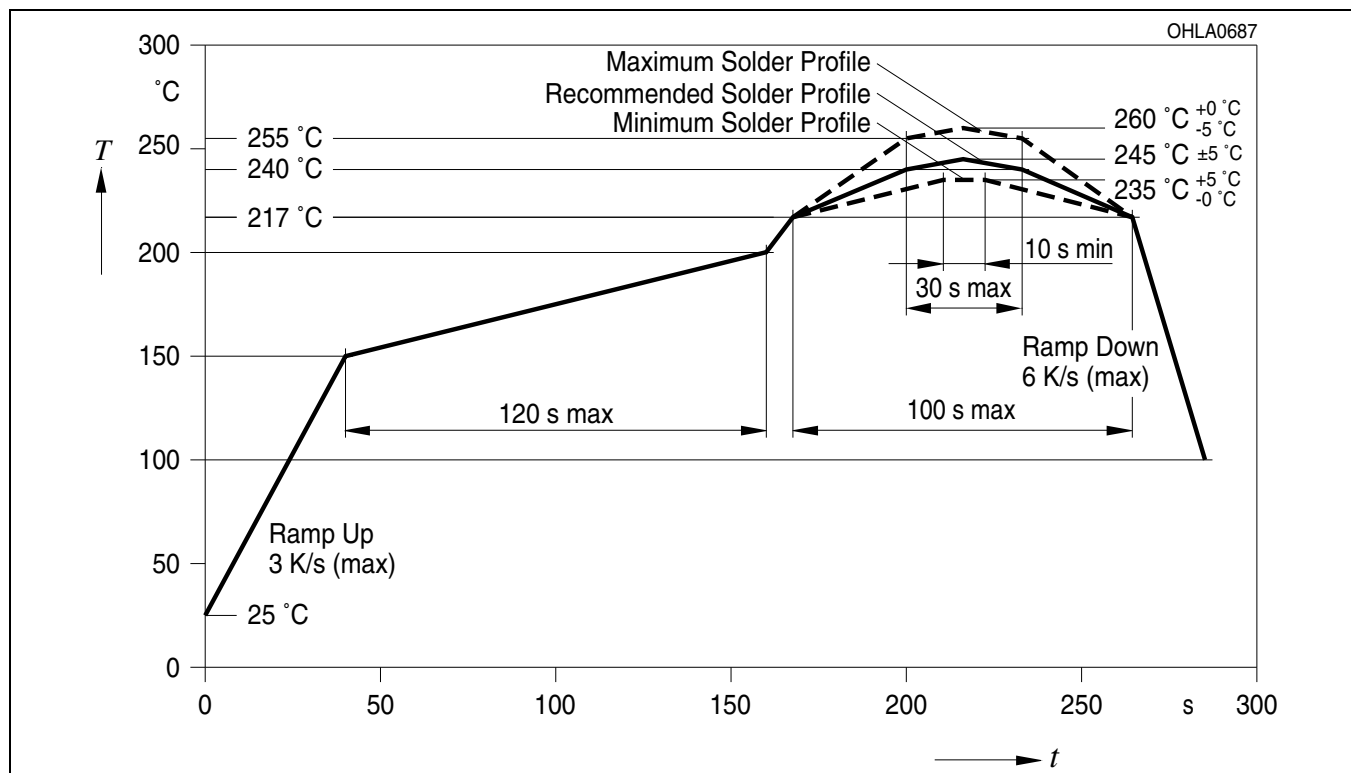

Published by  
**OSRAM Opto Semiconductors GmbH**  
Leibnizstrasse 4, D-93055 Regensburg  
[www.osram-os.com](http://www.osram-os.com)  
© All Rights Reserved.

EU RoHS and China RoHS compliant product



此产品符合欧盟 RoHS 指令的要求；

按照中国的相关法规和标准，不含有毒有害物质或元素。

The information describes the type of component and shall not be considered as assured characteristics. Due to the special conditions of the manufacturing processes of Sensor, the typical data or calculated correlations of technical parameters can only reflect statistical figures. These do not necessarily correspond to the actual parameters of each single product, which could differ from the typical data and calculated correlations or the typical characteristic line. If requested, e.g. because of technical improvements, these typ. data will be changed without any further notice. Terms of delivery and rights to change design reserved. Due to technical requirements components may contain dangerous substances. For information on the types in question please contact our Sales Organization.

**Packing**

Please use the recycling operators known to you. We can also help you – get in touch with your nearest sales office. By agreement we will take packing material back, if it is sorted. You must bear the costs of transport. For packing material that is returned to us unsorted or which we are not obliged to accept, we shall have to invoice you for any costs incurred.

**Components used in life-support devices or systems must be expressly authorized for such purpose!** Critical components<sup>1</sup>, may only be used in life-support devices or systems<sup>2</sup> with the express written approval of OSRAM OS.

<sup>1</sup> A critical component is a component used in a life-support device or system whose failure can reasonably be expected to cause the failure of that life-support device or system, or to affect its safety or effectiveness of that device or system.

<sup>2</sup> Life support devices or systems are intended (a) to be implanted in the human body, or (b) to support and/or maintain and sustain human life. If they fail, it is reasonable to assume that the health of the user may be endangered.