



SERIES 78B Right Angle Option

FEATURES

- Easy Access
- SPST Circuitry
- 1-10 and 12 positions available
- Sealed versions available

APPLICATIONS

Telecommunications, computers and peripherals, instruments and controls.

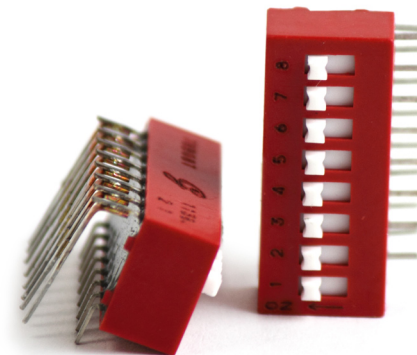

Series 78B DIMENSIONS in inches (and millimeters)

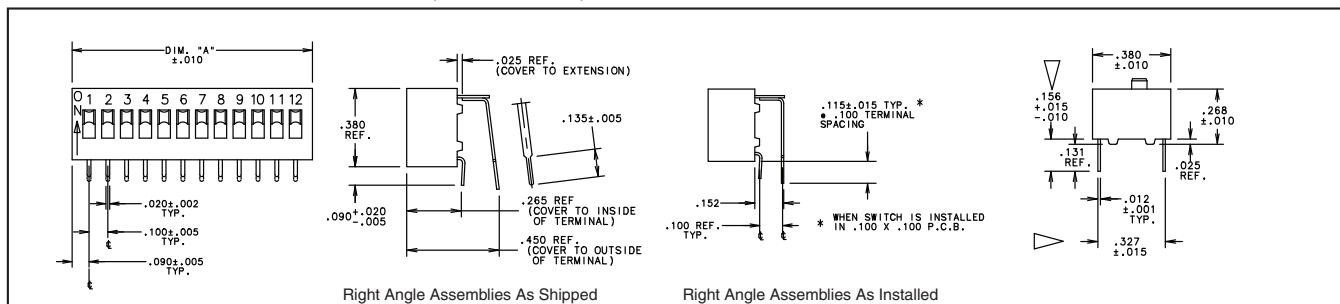

DIP Switches

SPECIFICATIONS

Mechanical

Mechanical Life: 2,000 operations per switch.

Operation Temp: -40°C to + 85°C

Storage Temp: -55°C to + 85°C

Vibration Test: Per Method 204, Test Condition B, 1 mS opening (10 mS allowed)

Shock Test: MIL-STD-202F METHOD 213 Test Condition A, 1ms (10 allowed)

Electrical

Electrical Life: 10,000 operations per switch 24VDC, 25mA.

Non-Switching Rating: 100mA, 50VDC.

Switching rating: 150mA, 30VDC;

10mA, 50mVDC

Contact Resistance: 30mΩ max. at initial.

Insulation Resistance: (at 100VDC) 5,000MΩ min.

Dielectric Strength: 750VAC/1 minute.

Capacitance: 2pF max.

Soldering and Cleaning Process

*For the most current soldering & cleaning processing guidelines, reference Grayhill Dip Switch Processing Information, Bulletin 1234

Cleaning tape sealed products:

Passes immersion test using water/detergent. Acceptable solutions include 1-1-1 trichlorethane, freon, (TF, TE, or TMS), isopropyl alcohol, detergent (140°F maximum). Terpene acceptable for Series 90 only. Solutions which are not recommended include acetone, methylenechloride, freon TMC. Pressure wash cleaning processes are not recommended for tape seal switches.

Wave Soldering: Recommended solder temperature: 500°F (260C) max 5 seconds.

Hand Soldering: Use a soldering iron of 30 Watts or less, controlled at 608°F (320° C) approximately 2 seconds while applying solder.

Cleaning: Tape sealed versions withstand cleaning processes.

Materials

Contact Ball: Brass with gold plating over nickel

Terminals: Brass with gold plating over nickel

Nonconductive Parts: Plastic UL94V-0

Potting Material: Epoxy

Shorting Member (Ball): Brass, gold-plated over nickel barrier.

Protective Cover: Polycarbonate.

Tape Seal: Polyester film

Tape Seal Integrity: Passes gross leak test using 125°C flourinert for 20 seconds minimum. Reference MIL-STD-202, Method 112.

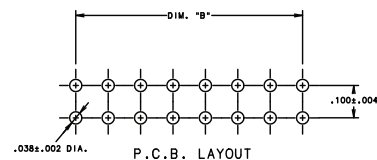
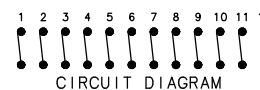

ORDERING INFORMATION

Series 78B, 78F, 78G, 78H, 78J, 78K, 78RB Styles available as right angle
Number of Positions 1 through 12 (depending on Series)
 RoHS compliant

78B08SRAT

Right Angle
S= Top Tape Sealed, Blank=Unsealed

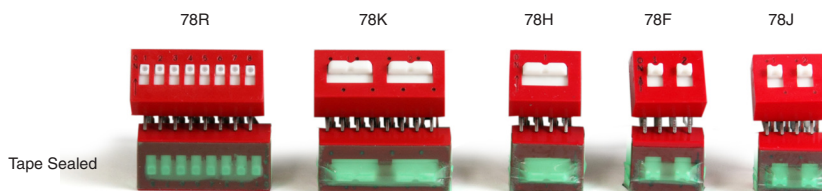



Grayhill DIP Switch Processing Information

The information provided within is intended as processing guidelines for the assembly, soldering, cleaning, and use of Grayhill DIP switches. This information supersedes any other process information that is available in Grayhill Inc. catalogs or data sheets as related to Grayhill Inc. standard DIP switch products. Please contact Grayhill Inc. for any questions related to the information in this document.

Mounting

Unless otherwise noted, Grayhill DIP switches are shipped with slides or rockers in the ON position and rotary DIP switches are shipped with the actuators in the 0 position. It is recommended that they be solder processed in those positions to ensure proper performance without issue.

Soldering

WAVE SOLDER: Switches that can be processed using wave solder equipment (thru hole soldering) are as follows:

Grayhill Series 76SB, 76PSB, 76RSB, 76SC, 76RSC, 76RSD, 76SD, 76STC, 76STD, 78B, 78RB, 78F, 78G, 78H, 78J, 78K, 90B, 94H (thru hole models), and 94R

Wave soldering guidelines: Solder wave temperature is 260°C. max. for 5 seconds max. (0.063" thick PCB). Exposure to flux should be kept to a minimum.

Manual soldering guidelines (for thru hole switches): Soldering temperature is 350C for soldering iron tip with 3 seconds maximum of dwell time.

REFLOW SOLDER: Switches that can be processed using reflow process equipment are as follows:

Grayhill Series 76HP, 78HF, 78HJ, 90B, 90HB, 94H, 94R, 97C, and 97R

Reflow soldering guidelines: Soldering temperature is 260C max. for 5 seconds, with a maximum of two reflow cycles at the maximum conditions. Switches should be allowed to cool for 3 to 5 minutes between reflow cycles. Reflow soldering should not be done to any Grayhill DIP switch products not listed directly above as the exposure to higher surface temperatures could cause permanent deformation of the plastic materials.

Recommended Maximum Soldering Conditions:

Reflow Soldering Profile:

(260°C Peak Temperature)

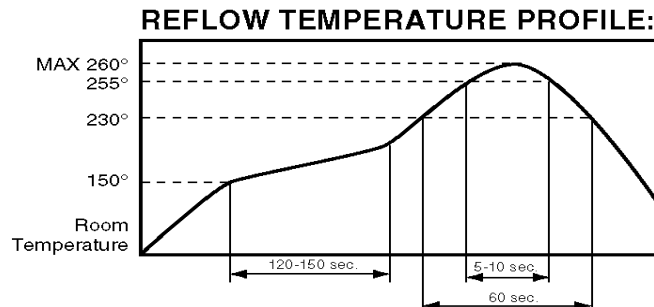

PCB Cleaning

In-line DIP switches that are tape sealed can be processed using certain washing processes as described below. Tape sealed switches can typically be identified by a suffix of ST or PT that follows after the series, switch style, and number of position identifiers (i.e., 76SB08ST). Non-tape sealed switches should not be subjected to any washing processes as they can introduce contaminants into the contact area of the switches. Rotary DIP products (94H & 94R) are internally sealed and can be processed the same as tape sealed products.

Tape sealed and rotary DIP switch products are qualified for immersion cleaning processes using alcohol or detergent based cleaning solvents at temperatures up to 140°F. maximum. Tape seal products must have the tape seal undisturbed until after any cleaning process. Cleaning processes that use ultrasonic agitation or that use pressurized sprays can defeat the tape and / or internal seals and allow contamination of the switches. They are not recommended for use on inline or rotary DIP products. Switches should not be washed directly after a soldering process. There should be a delay of at least three minutes to allow adequate time for cooling after soldering.

Tape seal integrity: Inline DIP products that are tape sealed are tested to meet and pass a gross leak test using 125°C Fluorinert for 20 seconds minimum. Reference MIL-202, Method 112.

Tape seal material:

76,78: Polyester film, rated to 170°F. maximum temperature

90: Polyimide film, rated to 260°C. maximum temperature