

DM54LS347/DM74LS347 BCD to 7-Segment Decoder/Driver

General Description

The 'LS347 is the same as the 'LS47 except that the Output OFF Voltage, V_{OH} , is specified as 7.0V rather than 15V, with the same I_{OH} limit of 250 μ A. For all other information please refer to the 'LS47 data sheet.

Connection Diagram

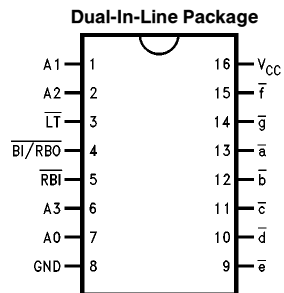

TL/F/10184-1

Order Number DM54LS347J, DM54LS347W,
DM74LS347M or DM74LS347N
See NS Package Number J16A, M16A, N16E or W16A

Logic Symbol

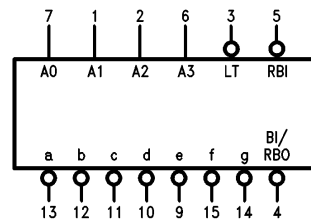

TL/F/10184-2

V_{CC} = Pin 16
GND = Pin 8

Pin Names	Description
A0–A3	BCD Inputs
\overline{RBI}	Ripple Blanking Input (Active LOW)
\overline{LT}	Lamp Test Input (Active LOW)
$\overline{BI/RBO}$	Blanking Input (Active LOW) or Ripple Blanking Output (Active LOW)
\overline{a} – \overline{g}	*Segment Outputs (Active LOW)

*OC—Open Collector

Absolute Maximum Ratings (Note)

If Military/Aerospace specified devices are required, please contact the National Semiconductor Sales Office/Distributors for availability and specifications.

Supply Voltage	7V
Input Voltage	7V
Operating Free Air Temperature Range	
DM54LS	–55°C to +125°C
DM74LS	0°C to +70°C
Storage Temperature Range	–65°C to +150°C

Note: The "Absolute Maximum Ratings" are those values beyond which the safety of the device cannot be guaranteed. The device should not be operated at these limits. The parametric values defined in the "Electrical Characteristics" table are not guaranteed at the absolute maximum ratings. The "Recommended Operating Conditions" table will define the conditions for actual device operation.

Recommended Operating Conditions

Symbol	Parameter	DM54LS347			DM74LS347			Units
		Min	Nom	Max	Min	Nom	Max	
V _{CC}	Supply Voltage	4.5	5	5.5	4.75	5	5.25	V
V _{IH}	High Level Input Voltage	2			2			V
V _{IL}	Low Level Input Voltage			0.7			0.8	V
I _{OH}	High Level Output Voltage			–50			–50	μA
I _{OL}	Low Level Output Current			12			24	mA
T _A	Free Air Operating Temperature	–55		125	0		70	°C

Electrical Characteristics over recommended operating free air temperature range (unless otherwise noted)

Symbol	Parameter	Conditions	Min	Typ (Note 1)	Max	Units
V _I	Input Clamp Voltage	V _{CC} = Min, I _I = –18 mA			–1.5	V
V _{OH}	High Level Output Voltage	V _{CC} = Min, I _{OH} = Max, V _{IL} = Max				V
V _{OL}	Low Level Output Voltage	V _{CC} = Min, I _{OL} = Max, V _{IH} = Min	DM54	2.5		
			DM74	2.7		
V _{OL}	Low Level Output Voltage	I _{OL} = 4 mA, V _{CC} = Min	DM54		0.4	V
			DM74		0.5	
I _I	Input Current @ Max Input Voltage	V _{CC} = Max, V _I = 7V V _I = 10V	DM74		0.1	mA
			DM54			
I _{IH}	High Level Input Current	V _{CC} = Max, V _I = 2.7V			20	μA
I _{IL}	Low Level Input Current	V _{CC} = Max, V _I = 0.4V	Other Input		–0.4	mA
			BI/RBO Input		–1.2	mA
I _{OS}	Short Circuit Output Current	V _{CC} = Max (Note 2)	DM54	–0.3	–2.0	mA
			DM74	–0.3	–2.0	
I _{CC}	Supply Current	V _{CC} = Max			13	mA
I _{OFF}		Segment Outputs, V _O = 7V			250	μA

Switching Characteristics

at V_{CC} = 5V and T_A = 25°C:

Symbol	Parameter	C _L = 15 pF		Units
		Min	Max	
t _{PLH}	Propagation Delay		100	ns
t _{PHL}	A _n to $\bar{a}-\bar{g}$		100	ns
t _{PLH}	Propagation Delay		100	ns
t _{PHL}	RBI to $\bar{a}-\bar{g}$		100	ns

Note 1: All typicals are at V_{CC} = 5V, T_A = 25°C.

Note 2: Not more than one output should be shorted at a time, and the duration should not exceed one second.

Physical Dimensions inches (millimeters)

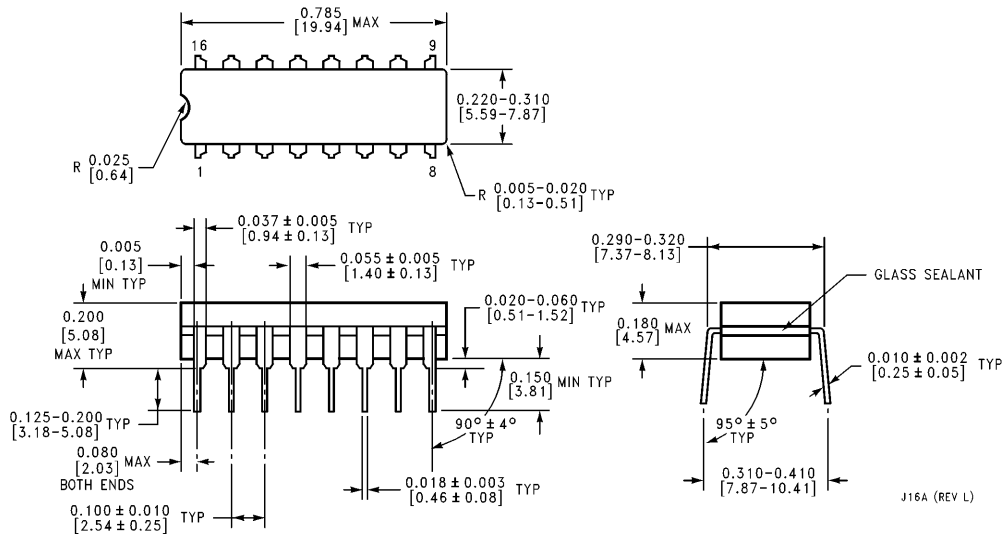

16-Lead Ceramic Dual-In-Line Package (J)
Order Number DM54LS347J
NS Package Number J16A

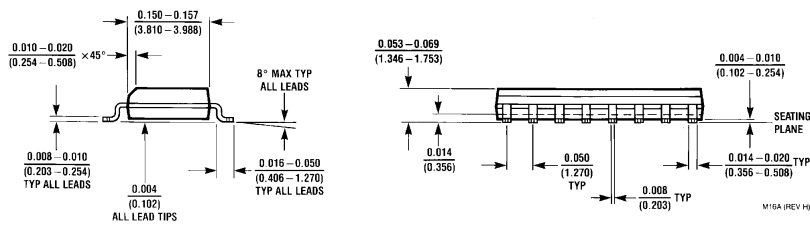
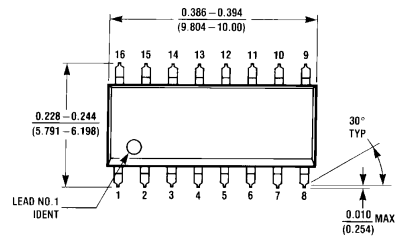

16-Lead Small Outline Molded Package (M)
Order Number DM74LS347M
NS Package Number M16A

Physical Dimensions inches (millimeters) (Continued)

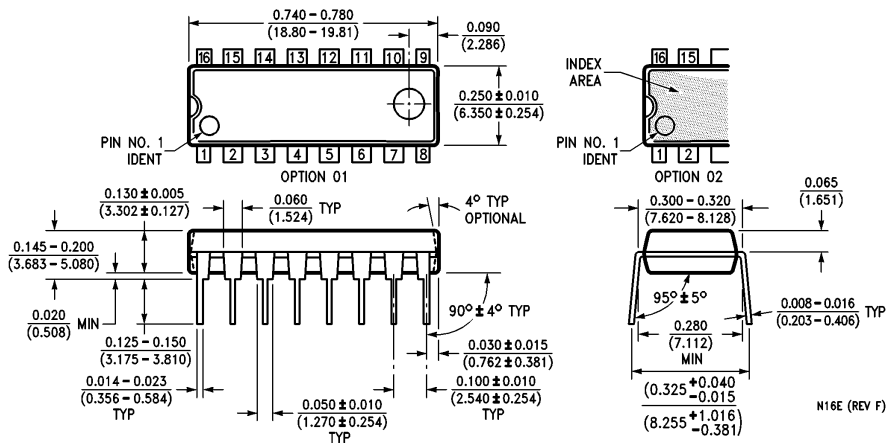

16-Lead Molded Dual-In-Line Package (N)
Order Number DM74LS347N
NS Package Number N16E

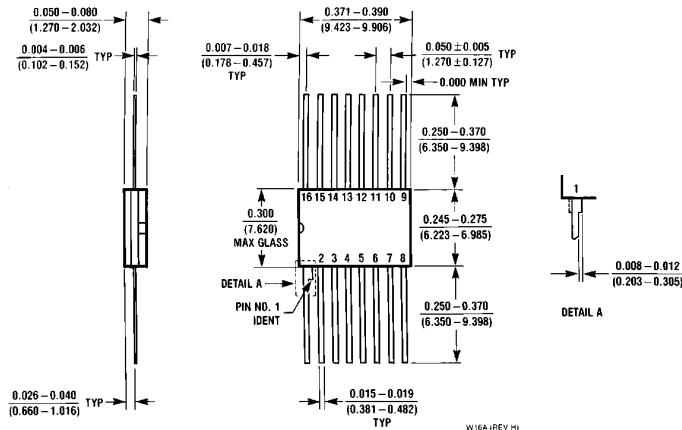

16-Lead Ceramic Flat Package (W)
Order Number DM54LS347W
NS Package Number W16A

LIFE SUPPORT POLICY

NATIONAL'S PRODUCTS ARE NOT AUTHORIZED FOR USE AS CRITICAL COMPONENTS IN LIFE SUPPORT DEVICES OR SYSTEMS WITHOUT THE EXPRESS WRITTEN APPROVAL OF THE PRESIDENT OF NATIONAL SEMICONDUCTOR CORPORATION. As used herein:

1. Life support devices or systems are devices or systems which, (a) are intended for surgical implant into the body, or (b) support or sustain life, and whose failure to perform, when properly used in accordance with instructions for use provided in the labeling, can be reasonably expected to result in a significant injury to the user.
2. A critical component is any component of a life support device or system whose failure to perform can be reasonably expected to cause the failure of the life support device or system, or to affect its safety or effectiveness.



National Semiconductor Corporation
 1111 West Bardin Road
 Arlington, TX 76017
 Tel: (800) 272-9959
 Fax: (800) 737-7018

National Semiconductor Europe
 Fax: (+49) 0-180-530 85 86
 Email: cnjwge@tevm2.nsc.com
 Deutsch Tel: (+49) 0-180-530 85 85
 English Tel: (+49) 0-180-532 78 32
 Français Tel: (+49) 0-180-532 93 58
 Italiano Tel: (+49) 0-180-534 16 80

National Semiconductor Hong Kong Ltd.
 19th Floor, Straight Block,
 Ocean Centre, 5 Canton Rd.
 Tsimshatsui, Kowloon
 Hong Kong
 Tel: (852) 2737-1600
 Fax: (852) 2736-9960

National Semiconductor Japan Ltd.
 Tel: 81-043-299-2309
 Fax: 81-043-299-2408

National does not assume any responsibility for use of any circuitry described, no circuit patent licenses are implied and National reserves the right at any time without notice to change said circuitry and specifications.