



AH4

High Dynamic Range Amplifier

Product Features

- 250-6000 MHz
- +41 dBm Output IP3
- 2.7 dB Noise Figure
- 13.5 dB Gain
- +21 dBm P1dB
- MTBF >100 Years
- 3 X 3 LGA SMT Package
- Single +5 Bias Supply



Product Description

The AH4 is a high dynamic range amplifier packaged in a Land Grid Array (LGA) surface mount package for applications thru 6 GHz. The combination of low noise figure and high output IP3 at the same bias point makes it ideal for receiver and transmitter applications. The AH4 achieves +41 dBm OIP3 at a mounting temperature of 80°C with an associated MTBF of >100 years⁴. The package is a 3 X 3 Land Grid Array. All devices are 100% RF and I/C tested. The product is targeted for applications in the W-LAN and UHF bands where high linearity is required.

Functional Diagram

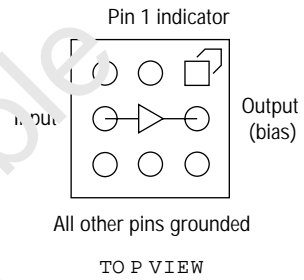

Specifications

Parameter	Units	Min.	Typical	Max.
Frequency Range	GHz		0.25 - 6	
S21 - Gain	dB	12.4	13.5	
S11 - Input Return Loss	dB		-5	
S22 - Output Return Loss	dB		-15	
Output IP3	dBm	+37	+41	
Output P1dB	dBm		+21	
Noise Figure	dB		2.7	
Operating Current Range	mA	120	150	150
Supply Voltage	V		5	

Test conditions unless otherwise noted:
 1. T = 22°C, Vdd = 5.0 V, Frequency = 800 MHz, 50 W system.
 2. OIP3 measured with two tones at an output power of 0 dBm, tone separation by 10 MHz. The suppression on the larger tone product is used to calculate the OIP3 using a 1:1 slope rule.
 3. Degradation of OIP3 occurs at low temperatures. Minimum typical OIP3 at 0°C is 35 dBm.
 4. MTBF calculated with channel temperature at 150°C.

Absolute Maximum Ratings

Parameter	Rating
Operating Case Temperature	-40 to +80°C
Storage Temperature	-55 to +125 °C
Junction Temperature	+155°C
Supply Voltage	+6.0 V
Input RF Power (continuous)	+10 dBm

Operation of this device above any of these parameters may cause permanent damage.

Typical Parameters

Parameter	Units	Typical
Frequency	GHz	5.8
S21	dB	9.3
S11	dB	-15.5
S22	dB	-16.2
Output IP3	dBm	+38.5
Output P1dB	dBm	+21.2
Noise Figure	dB	5.6

Typical parameters reflect performance in an application circuit.

Ordering Information

Part No.	Description
AH4	High Dynamic Range Amplifier (Available in tape and reel)



AH4

High Dynamic Range Amplifier

Performance Charts (V_{ds} = 5.0 V, I_{ds} = 150 mA, T = 22°C, unmatched device in a 50 ohm system)

OIP3 vs. Frequency

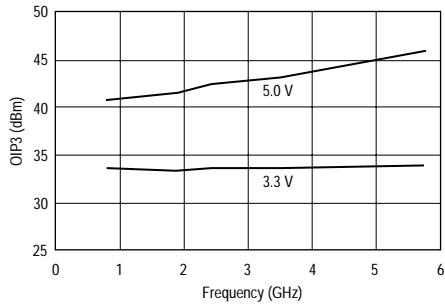

Noise Figure vs. Frequency

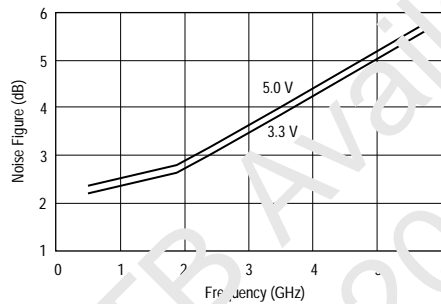

OIP3 vs. Power Out

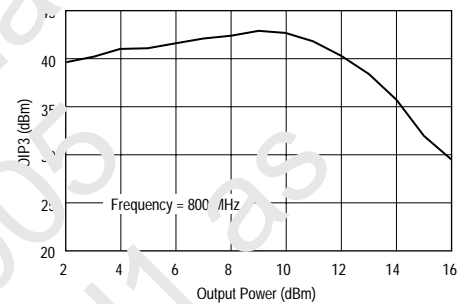

OIP3 vs. Temperature

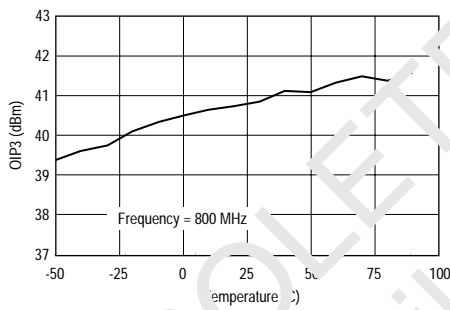

Gain vs. Frequency, Temperature

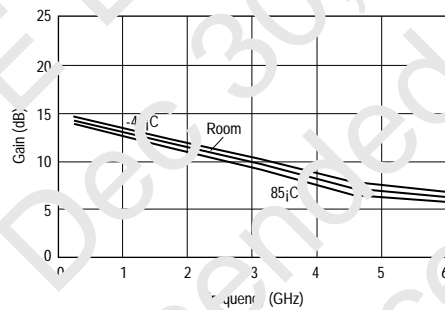

S-Parameters

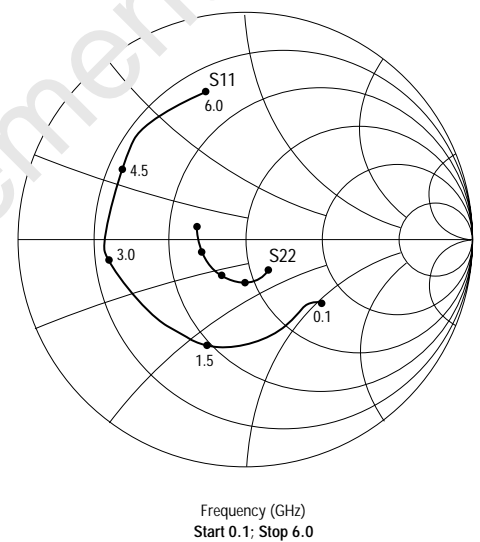

MTBF vs. Temperature

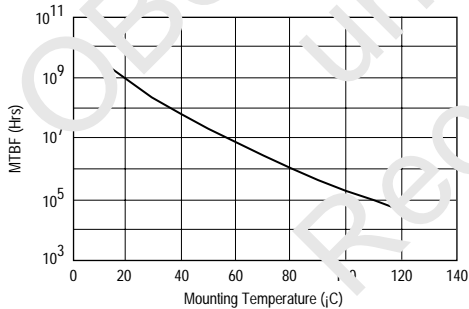

Return Loss vs. Frequency

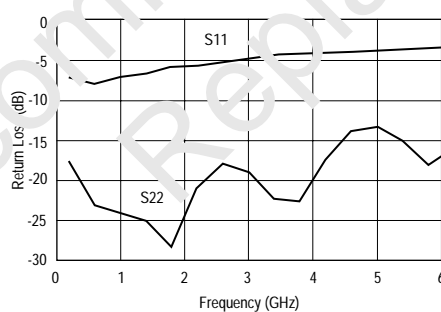



AH4

High Dynamic Range Amplifier

Application Circuit: 5.8 GHz

Typical Performance (50 Ohm System)

Frequency	5.8 GHz
Magnitude S21	9.3 dB
Magnitude S11	-15.5 dB
Magnitude S22	-16.2 dB
OIP3	38.5 dBm
Noise Figure	5.6 dB
Bias	Vds = 5 V, Id = 140 mA

Schematic

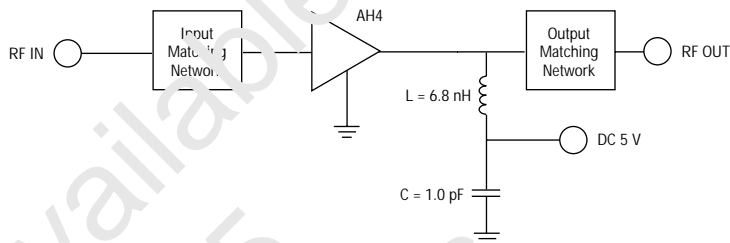

S-Parameters

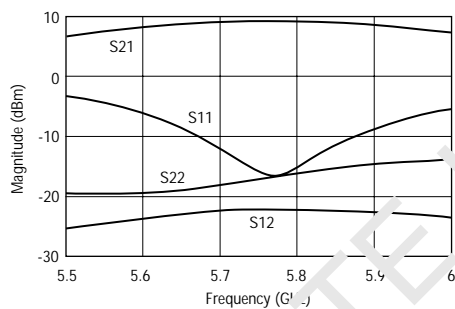

PCB-4003 Board Layout (T = 20 Mil)

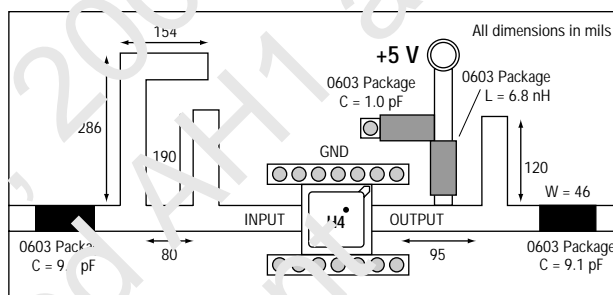



AH4

High Dynamic Range Amplifier

Outline Drawing

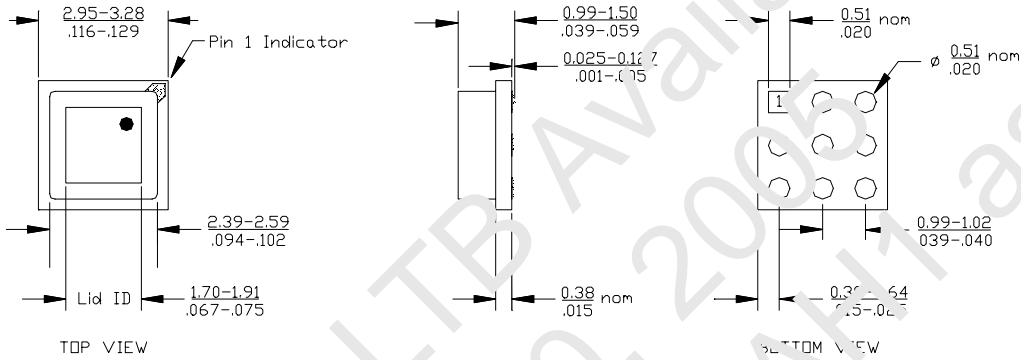

Note: Solder pads are coplanar to within +/- 1 mil.

Land Pattern

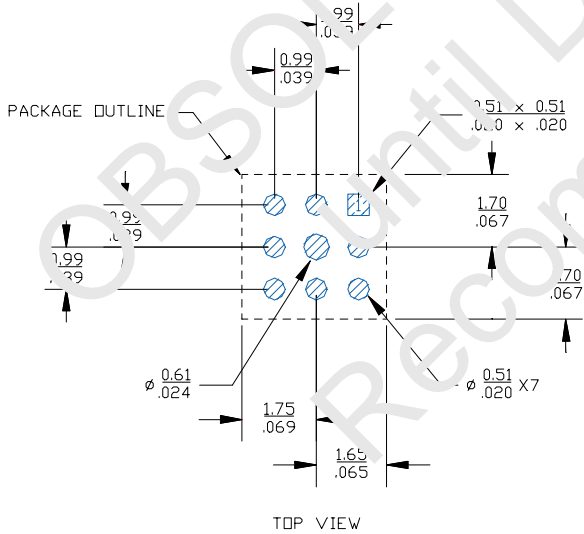

mm
inch

Mounting Configuration

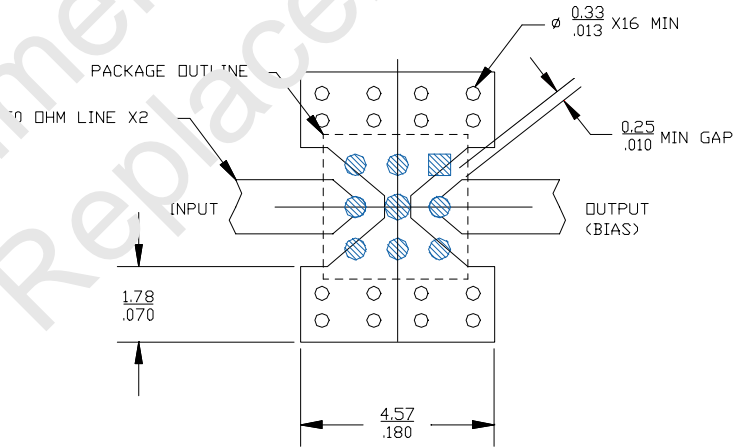

- Notes:
1. Ground vias are critical for thermal and RF grounding considerations.
 2. A minimum of 16 ground vias are required.
 3. If your PCB design rules allow, ground vias should be placed under the land pattern for better RF and thermal performance. Otherwise ground vias should be placed as close to land pattern as possible.
 4. Trace width depends on PC board.

Specifications and information are subject to change without notice.



Caution! ESD sensitive device.



AH4

High Dynamic Range Amplifier

Typical Test Data

S-Parameters (Vds = 5.0 V, Ids = 150 mA, T = 22°C, unmatched device in a 50 ohm system)

Freq (MHz)	S11 (Mag)	S11 (Ang)	S21 (Mag)	S21 (Ang)	S12 (Mag)	S12 (Ang)	S22 (Mag)	S22 (Ang)
0.100	0.57451	-36.7211	6.22510	158.863	0.08154	25.7213	0.29530	-50.4581
0.500	0.39012	-52.6403	5.05950	138.753	0.09253	-14.3986	0.11428	-49.7803
1.000	0.43598	-79.3707	4.62450	105.834	0.09057	-37.7971	0.11655	-42.2307
1.500	0.49058	-107.430	4.29160	66.9102	0.09057	-65.5168	0.09396	-49.3091
2.000	0.50663	-130.830	3.92950	23.0265	0.08753	-88.7364	0.07730	-82.7912
2.500	0.53833	-152.040	3.53160	-0.02812	0.08675	-111.803	0.13147	-99.6609
3.000	0.58922	-166.600	3.14930	-30.6987	0.08583	-133.880	0.14577	-96.0661
3.500	0.61700	-177.600	2.87010	-60.0551	0.08275	-154.475	0.12467	-101.940
4.000	0.60784	168.290	2.67170	-89.5310	0.08172	-177.290	0.11160	-138.221
4.500	0.61721	151.660	2.45240	-120.411	0.07608	-160.906	0.17744	-159.220
5.000	0.64437	140.740	2.20659	-148.853	0.06934	141.869	0.22888	-156.050
5.500	0.66196	134.750	2.04880	-175.280	0.06551	123.875	0.22484	-152.180
6.000	0.65930	123.910	1.96780	-156.702	0.06418	105.131	0.18699	-166.460

S-Parameters (Vds = 3.0 V, Ids = 150 mA, T = 22°C, unmatched device in a 50 ohm system)

Freq (MHz)	S11 (Mag)	S11 (Ang)	S21 (Mag)	S21 (Ang)	S12 (Mag)	S12 (Ang)	S22 (Mag)	S22 (Ang)
0.100	0.57805	-36.5721	6.16670	159.023	0.07253	26.3833	0.25361	-58.0261
0.500	0.38854	-52.8703	5.00720	139.047	0.06944	-13.5516	0.08258	-72.7803
1.000	0.43468	-79.3207	4.58500	106.424	0.07807	-36.4471	0.07604	-59.9507
1.500	0.48940	-107.290	4.26200	67.5402	0.07797	-63.9678	0.05020	-73.4551
2.000	0.50620	-130.680	3.90720	33.9031	0.08807	-86.5774	0.07310	-116.030
2.500	0.53901	-151.950	3.51590	1.03923	0.08630	-109.709	0.11090	-124.210
3.000	0.53960	-166.450	3.14180	-29.5557	0.08398	-130.864	0.11302	-116.000
3.500	0.61034	-177.220	2.86510	-58.2084	0.08310	-151.652	0.08809	-125.850
4.000	0.60785	168.250	2.66060	-83.2250	0.08316	-174.304	0.10005	-168.450
4.500	0.61898	151.760	2.44330	-118.810	0.07827	164.379	0.17247	-177.590
5.000	0.64598	140.520	2.20600	-147.007	0.07301	144.508	0.20946	-169.910
5.500	0.66137	134.970	2.05100	-173.437	0.06866	127.571	0.19151	-164.990
6.000	0.66100	124.160	1.96820	-158.438	0.06887	108.238	0.16086	-177.189