

SANYO Semiconductors
DATA SHEET

An ON Semiconductor Company

Monolithic Linear IC

LA4535MC — For 1.5V Headphone Stereo Power Amplifier

Features

- Low current drain.
- 16Ω load drive capability.
- Excellent reduced voltage characteristics.
- Excellent power supply ripple rejection.
- Minimum number of external parts required (no input capacitor, feedback capacitor required).
- Less harmonic interference in radio band.
- On-chip power switch function, muting function.

Specifications

Absolute Maximum Ratings at Ta = 25°C

Parameter	Symbol	Conditions	Ratings	Unit
Maximum supply voltage	V _{CC} max	Quiescent	4.5	V
Allowable power dissipation	Pd max		290	mW
Operating temperature	Topr		-20 to +75	°C
Storage temperature	Tstg		-40 to +125	°C

Operating Conditions at Ta = 25°C

Parameter	Symbol	Conditions	Ratings	Unit
Recommended supply voltage	V _{CC}		1.5	V
Operating voltage range	V _{CC} op		0.9 to 4.0	V
Recommended load resistance	R _L		16 to 32	Ω

■ Any and all SANYO Semiconductor Co.,Ltd. products described or contained herein are, with regard to "standard application", intended for the use as general electronics equipment. The products mentioned herein shall not be intended for use for any "special application" (medical equipment whose purpose is to sustain life, aerospace instrument, nuclear control device, burning appliances, transportation machine, traffic signal system, safety equipment etc.) that shall require extremely high level of reliability and can directly threaten human lives in case of failure or malfunction of the product or may cause harm to human bodies, nor shall they grant any guarantee thereof. If you should intend to use our products for new introduction or other application different from current conditions on the usage of automotive device, communication device, office equipment, industrial equipment etc. , please consult with us about usage condition (temperature, operation time etc.) prior to the intended use. If there is no consultation or inquiry before the intended use, our customer shall be solely responsible for the use.

■ Specifications of any and all SANYO Semiconductor Co.,Ltd. products described or contained herein stipulate the performance, characteristics, and functions of the described products in the independent state, and are not guarantees of the performance, characteristics, and functions of the described products as mounted in the customer's products or equipment. To verify symptoms and states that cannot be evaluated in an independent device, the customer should always evaluate and test devices mounted in the customer's products or equipment.

SANYO Semiconductor Co., Ltd.
<http://www.sanyosemi.com/en/network/>

LA4535MC

Electrical Characteristics at $T_a = 25^\circ\text{C}$, $R_L = 16\Omega$, $R_g = 600\Omega$, See specified Test Circuit.

Parameter	Symbol	Conditions	Ratings			Unit
			min	typ	max	
Quiescent current *1	I_{CCO1}	$V_{CC} = 1.2\text{V}$, quiescent		3.5	6.0	mA
	I_{CCO2}	$V_{CC} = 2.5\text{V}$, pin 10 \rightarrow GND		1.5	2.5	mA
	I_{CCO3}	$V_{CC} = 2.5\text{V}$, pin 1 \rightarrow GND			1.0	μA
Voltage gain	VG1	$V_{CC} = 1.2\text{V}$, $f = 1\text{kHz}$, $V_O = -20\text{dBm}$	20.5	22	23	dB
	VG2	$V_{CC} = 0.9\text{V}$, $f = 1\text{kHz}$, $V_O = -20\text{dBm}$	19.5	22	23	dB
Voltage gain difference	ΔVG1	$V_{CC} = 1.2\text{V}$, $f = 1\text{kHz}$, $V_O = -20\text{dBm}$			1.0	dB
	ΔVG2	$V_{CC} = 0.9\text{V}$, $f = 1\text{kHz}$, $V_O = -20\text{dBm}$			1.0	dB
Total harmonic distortion	THD	$V_{CC} = 1.2\text{V}$, $f = 1\text{kHz}$, $P_O = 0.5\text{mW}$		0.8	1.5	%
Output power	P_O	$V_{CC} = 1.5\text{V}$, $f = 1\text{kHz}$, THD = 10%	5	8		mW
Crosstalk	CT	$V_{CC} = 1.2\text{V}$, $f = 100\text{Hz}$, $R_g = 1\text{k}\Omega$, $V_O = -20\text{dB}$	40	45		dB
Ripple rejection	SVRR	$V_{CC} = 1.0\text{V}$, $f = 100\text{Hz}$, $R_g = 1\text{k}\Omega$, $V_R = -30\text{dBm}$, BPF = 100Hz	45	50		dB
Output noise voltage	V_{NO}	$V_{CC} = 2.5\text{V}$, $R_g = 1\text{k}\Omega$, BPF = 20Hz to 20kHz		30	44	μV
Power off effect	$V_{O(\text{off})}$	$V_{CC} = 0.9\text{V}$, $f = 100\text{Hz}$, pin 1 \rightarrow GND, $V_{IN} = -10\text{dB}$			-80	dBm
Muting effect	$V_{O(\text{MT})}$	$V_{CC} = 0.9\text{V}$, $f = 100\text{Hz}$, pin 10 \rightarrow GND, $V_{IN} = -10\text{dB}$			-80	dBm
Power on current sensitivity	$I_1(\text{on})$	$V_{CC} = 0.85\text{V}$, $V_5 \geq 0.5\text{V}$		0.1	1.0	μA
Power off voltage sensitivity	$V_1(\text{off})$	$V_{CC} = 0.85\text{V}$, $V_5 \leq 0.1\text{V}$	0.5	0.65		V
Muting off current sensitivity	$I_{10(\text{off})}$	$V_{CC} = 0.85\text{V}$, $V_5 \geq 0.5\text{V}$		0.3	1.0	μA
Muting on voltage sensitivity	$V_{10(\text{on})}$	$V_{CC} = 0.85\text{V}$, $V_5 \leq 0.1\text{V}$	0.5	0.65		V

Note) The quiescent current is represented by the current flowing into pin 6. The respective maximum currents flowing into pin 1 and pin 10 are calculated by $(V_{\text{pin } -0.5} / 16 [V/k\Omega])$ and the total current increases by these current values.

Package Dimensions

unit : mm (typ)

3426

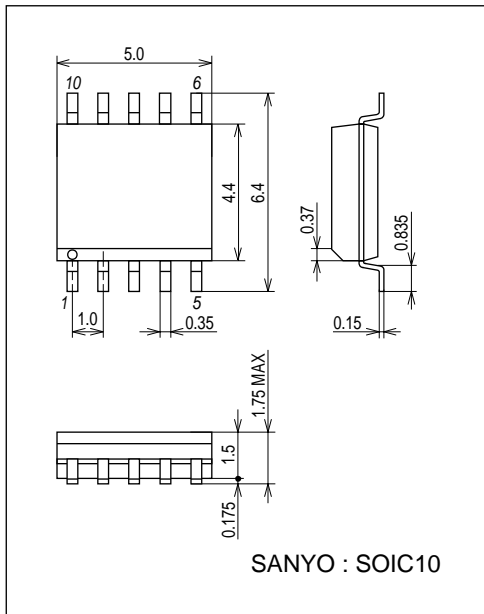

LA4535MC

Block Diagram

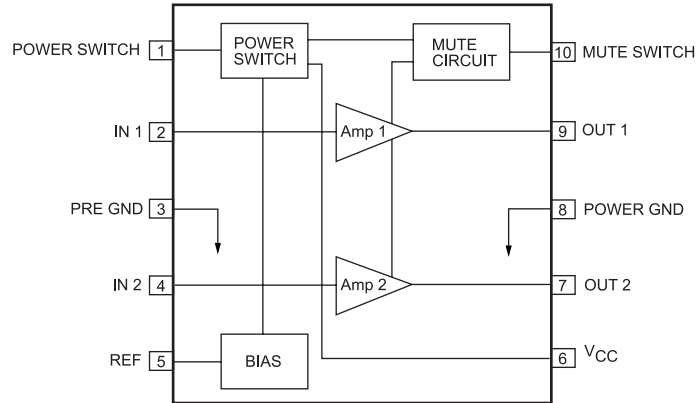

Test Circuit

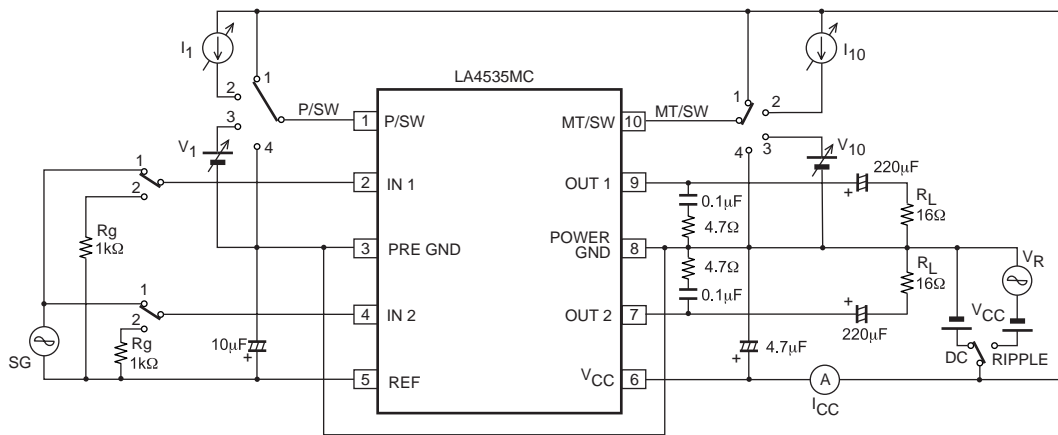

Sample Application Circuit

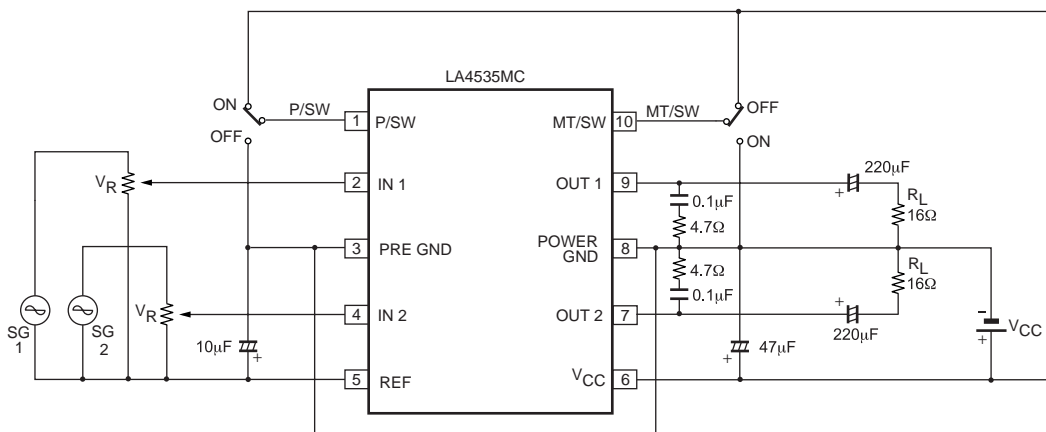

LA4535MC

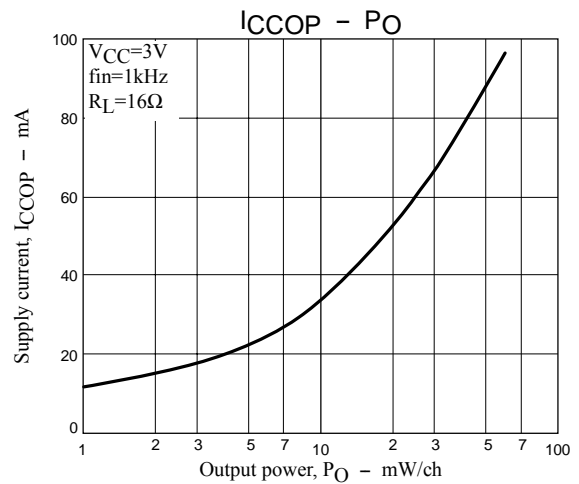
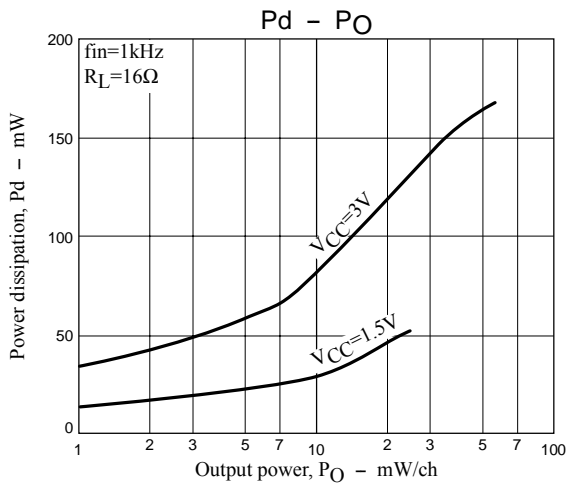
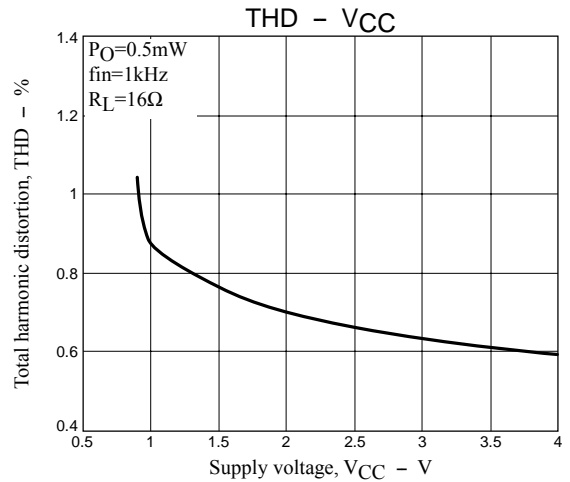
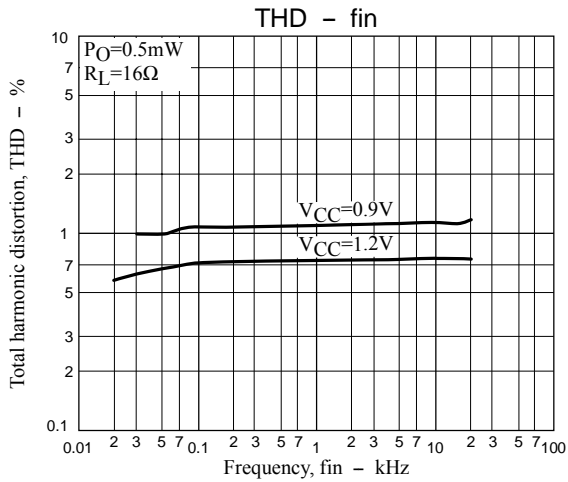
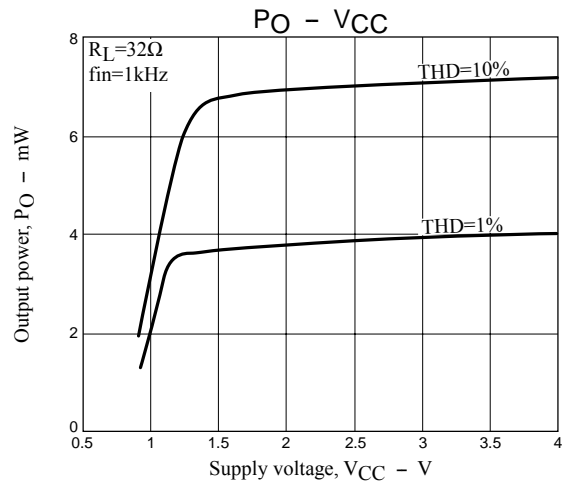
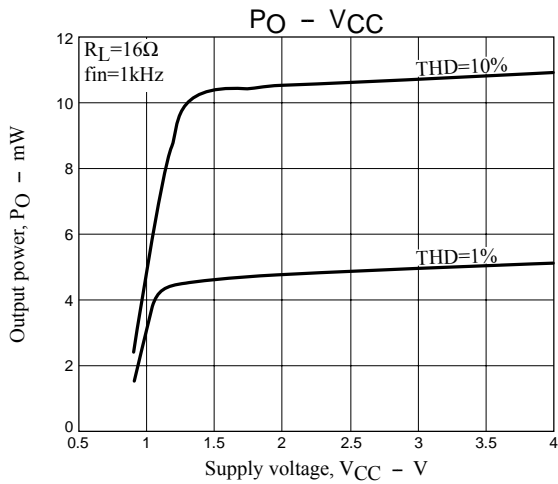
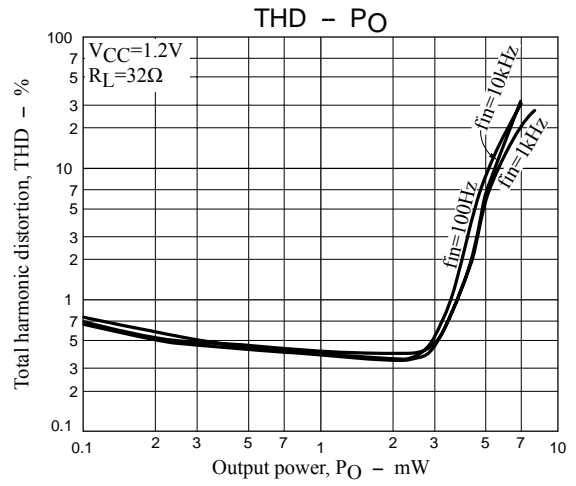
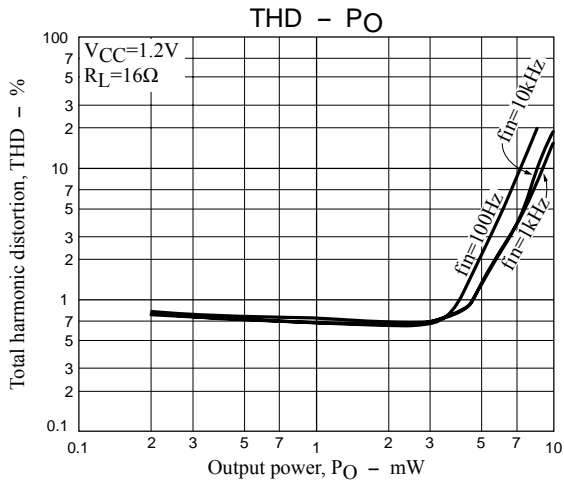

LA4535MC

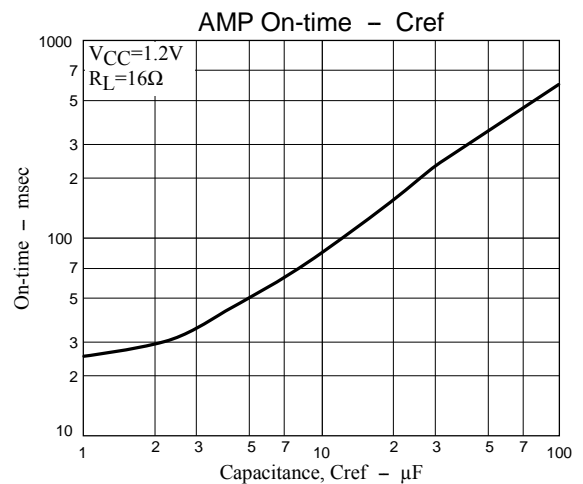
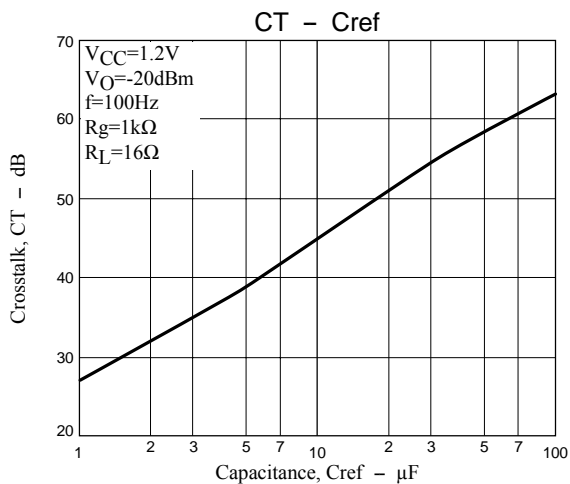
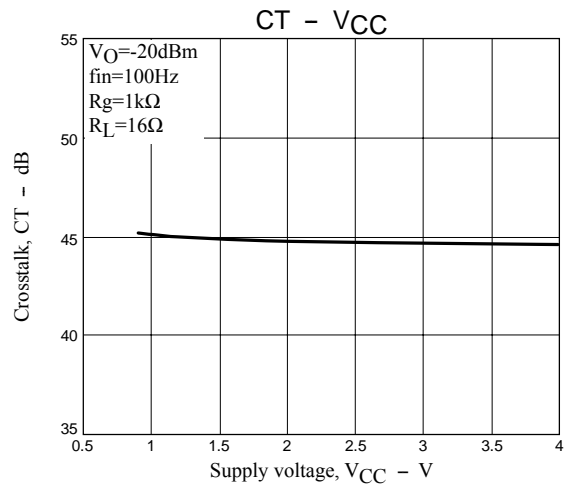
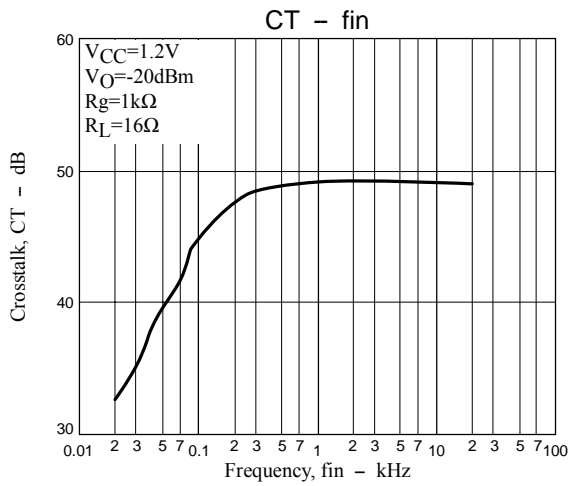
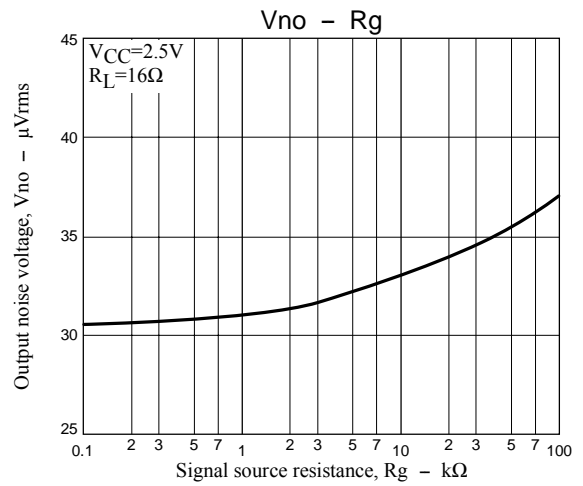
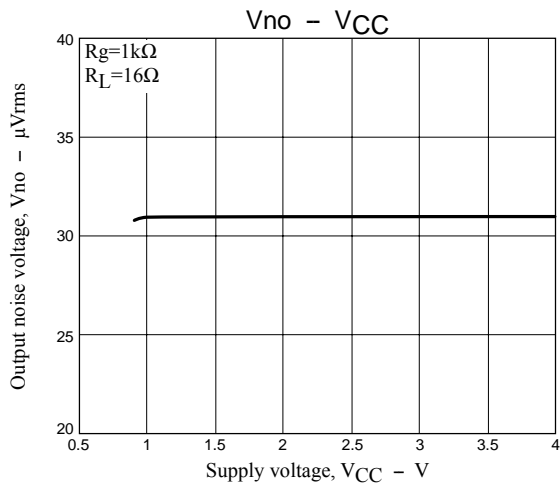
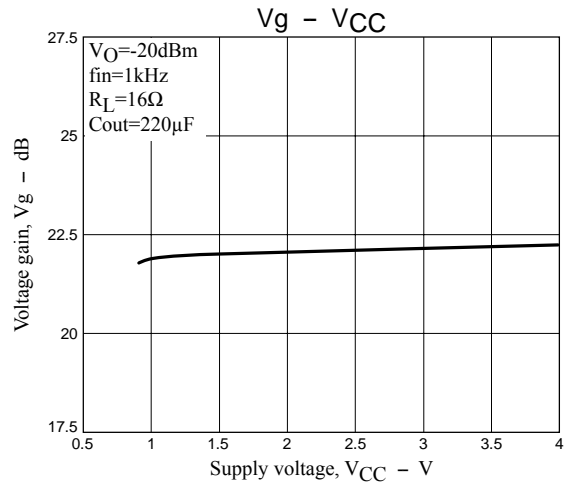
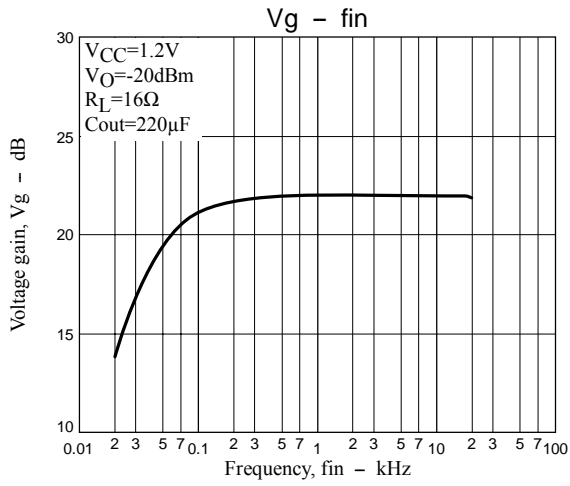

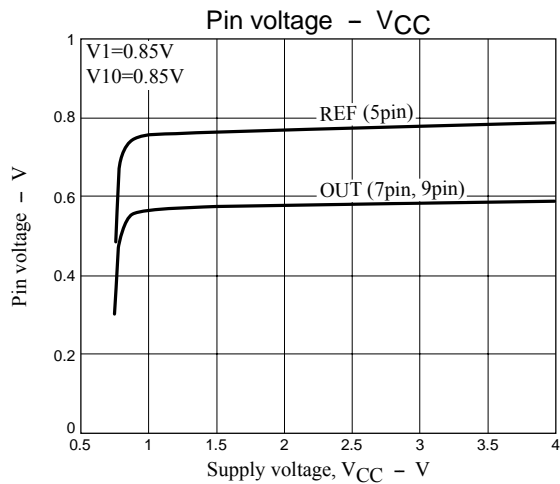
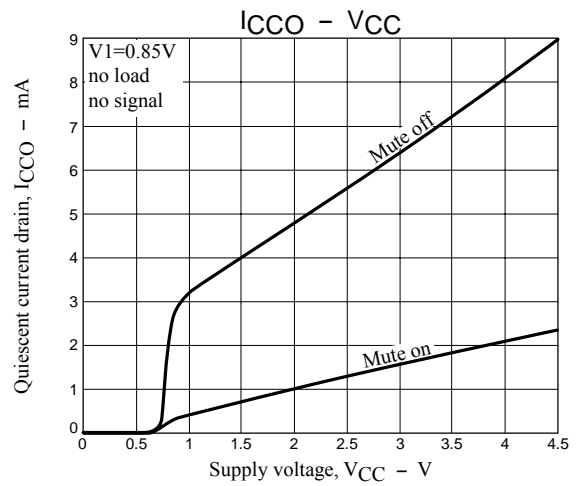
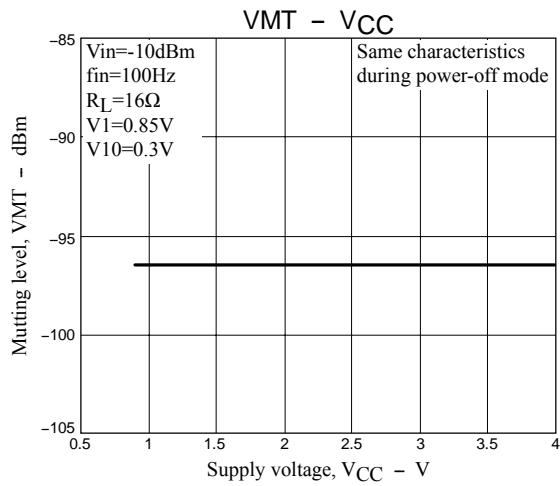
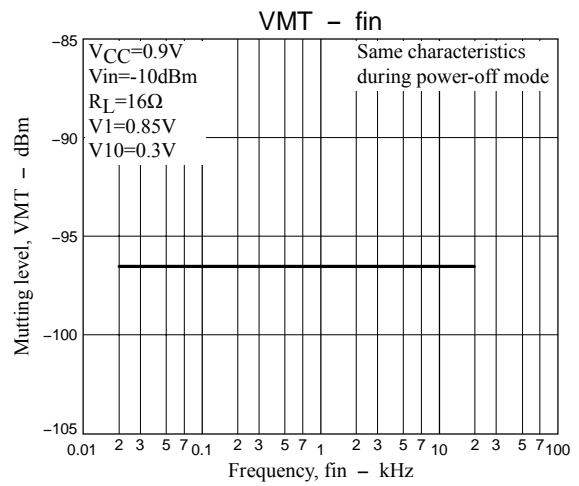
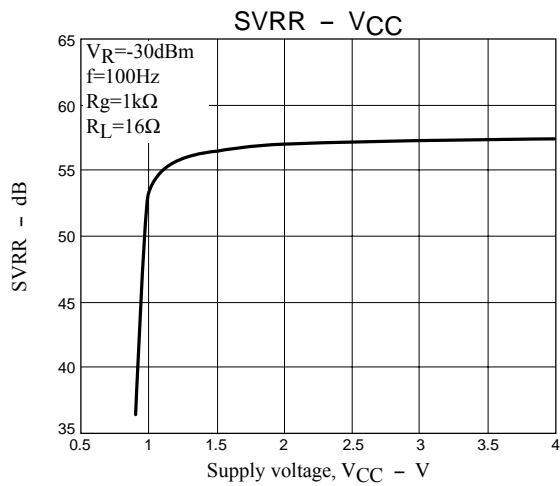
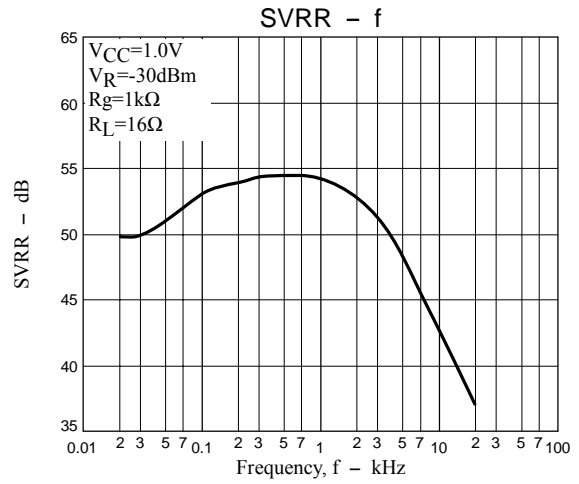
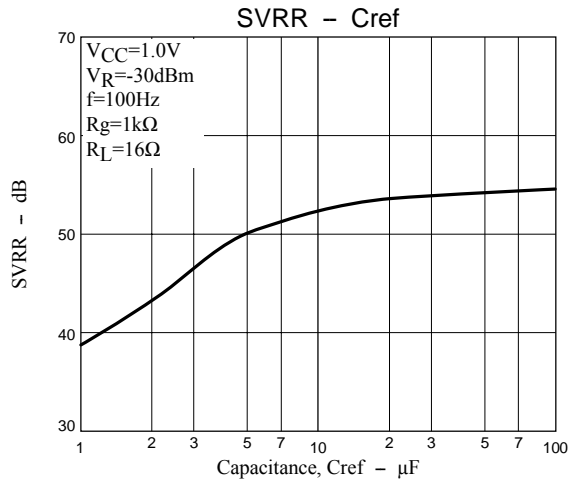

- SANYO Semiconductor Co.,Ltd. assumes no responsibility for equipment failures that result from using products at values that exceed, even momentarily, rated values (such as maximum ratings, operating condition ranges, or other parameters) listed in products specifications of any and all SANYO Semiconductor Co.,Ltd. products described or contained herein.
- Regarding monolithic semiconductors, if you should intend to use this IC continuously under high temperature, high current, high voltage, or drastic temperature change, even if it is used within the range of absolute maximum ratings or operating conditions, there is a possibility of decrease reliability. Please contact us for a confirmation.
- SANYO Semiconductor Co.,Ltd. strives to supply high-quality high-reliability products, however, any and all semiconductor products fail or malfunction with some probability. It is possible that these probabilistic failures or malfunction could give rise to accidents or events that could endanger human lives, trouble that could give rise to smoke or fire, or accidents that could cause damage to other property. When designing equipment, adopt safety measures so that these kinds of accidents or events cannot occur. Such measures include but are not limited to protective circuits and error prevention circuits for safe design, redundant design, and structural design.
- In the event that any or all SANYO Semiconductor Co.,Ltd. products described or contained herein are controlled under any of applicable local export control laws and regulations, such products may require the export license from the authorities concerned in accordance with the above law.
- No part of this publication may be reproduced or transmitted in any form or by any means, electronic or mechanical, including photocopying and recording, or any information storage or retrieval system, or otherwise, without the prior written consent of SANYO Semiconductor Co.,Ltd.
- Any and all information described or contained herein are subject to change without notice due to product/technology improvement, etc. When designing equipment, refer to the "Delivery Specification" for the SANYO Semiconductor Co.,Ltd. product that you intend to use.
- Upon using the technical information or products described herein, neither warranty nor license shall be granted with regard to intellectual property rights or any other rights of SANYO Semiconductor Co.,Ltd. or any third party. SANYO Semiconductor Co.,Ltd. shall not be liable for any claim or suits with regard to a third party's intellectual property rights which has resulted from the use of the technical information and products mentioned above.

This catalog provides information as of January, 2013. Specifications and information herein are subject to change without notice.