



T-73-53

LM106/LM206/LM306 Voltage Comparator

General Description

The LM106 series are high-speed voltage comparators designed to accurately detect low-level analog signals and drive a digital load. They are equivalent to an LM710, combined with a two input NAND gate and an output buffer. The circuits can drive RTL, DTL or TTL integrated circuits directly. Furthermore, their outputs can switch voltages up to 24V at currents as high as 10 mA.

The devices have short-circuit protection which limits the inrush current when it is used to drive incandescent lamps, in addition to preventing damage from accidental shorts to the positive supply. The speed is equivalent to that of an LM710. However, they are even faster where buffers and additional logic circuitry can be eliminated by the increased flexibility of the LM106 series. They can also be operated from any negative supply voltage between -3V and -12V with little effect on performance.

The LM106 is specified for operation over the -55°C to +125°C military temperature range. The LM206 is specified for operation over the -25°C to +85°C temperature range. The LM306 is specified for operation over 0°C to +70°C temperature range.

Features

- Improved accuracy
- Fan-out of 10 with DTL or TTL
- Added logic or strobe capability
- Useful as a relay or lamp driver
- Plug-in replacement for the LM710
- 40 ns maximum response time

Schematic and Connection Diagrams**

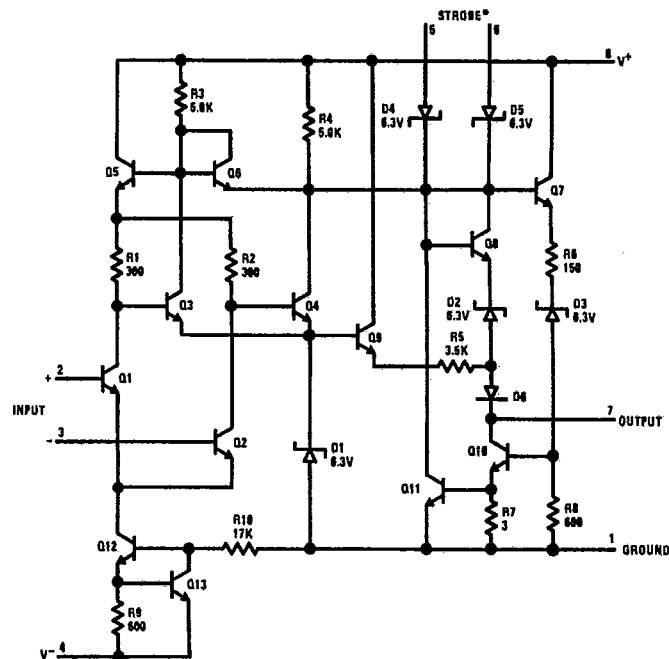

TL/H/7756-1

*Grounding either strobe forces the output to -0.5V (typ.). To disable strobe function, connect strobes to V+ or leave open.

**Pin connections shown are for TO-5 package.

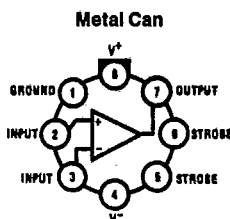

TL/H/7756-2

Top View

Note: Pin 4 connected to case.

Order Number LM106H,
LM206H or LM306H
See NS Package Number H08A

5

LM106/LM206/LM306

Absolute Maximum Ratings

If Military/Aerospace specified devices are required, please contact the National Semiconductor Sales Office/Distributors for availability and specifications. (Note 6)

Positive Supply Voltage	15V
Negative Supply Voltage	-15V
Output Voltage	24V
Output to Negative Supply Voltage	30V
Differential Input Voltage	±5V
Input Voltage	±7V

Power Dissipation (Note 1)	600 mW	
Output Short Circuit Duration	10 seconds	
Operating Temperature Range	T_{MIN} T_{MAX}	
	LM106	-55°C to +125°C
	LM206	-25°C to +85°C
LM306	0°C to +70°C	
Storage Temperature Range	-65°C to +150°C	
Lead Temperature (Soldering, 10 sec.)	300°C	
ESD rating to be determined.		

Electrical Characteristics (Note 2)

Parameter	Conditions	LM106/LM206			LM306			Units
		Min	Typ	Max	Min	Typ	Max	
Input Offset Voltage	(Note 3)		0.5	2.0		1.6	5.0	mV
Input Offset Current	(Note 3)		0.7	3.0		1.8	5.0	μA
Input Bias Current			10	20		16	25	μA
Response Time	R _L = 390Ω to 5V C _L = 15 pF, (Note 4)		28	40		28	40	ns
Saturation Voltage	V _{IN} ≤ -5 mV, I _{OUT} = 100 mA		1.0	1.5		0.8	2.0	V
	V _{IN} ≤ -7 mV, I _{OUT} = 100 mA							V
Output Leakage Current	V _{IN} ≥ 5 mV, 8V ≤ V _{OUT} ≤ 24V V _{IN} ≥ 7 mV, 8V ≤ V _{OUT} ≤ 24V		0.02	1.0		0.02	2.0	μA

THE FOLLOWING SPECIFICATIONS APPLY FOR T_{MIN} ≤ T_A ≤ T_{MAX} (Note 5)

Input Offset Voltage	(Note 3)			3.0			6.5	mV
Average Temperature Coefficient of Input Offset Voltage			3.0	10		5	20	μV/°C
Input Offset Current	T _L ≤ T _A ≤ 25°C, (Note 3) 25°C ≤ T _A ≤ T _H		1.8	7.0		2.4	7.5	μA
			0.25	3.0			5.0	μA
Average Temperature Coefficient of Input Offset Current	25°C ≤ T _A ≤ T _H T _L ≤ T _A ≤ 25°C		5.0	25		15	50	nA/°C
			15	75		24	100	nA/°C
Input Bias Current	T _L ≤ T _A ≤ 25°C 25°C ≤ T _A ≤ T _H			45		25	40	μA
				20			25	μA
Input Voltage Range	-7V ≥ V ₋ ≥ -12V	±5.0			±5.0			V
Differential Input Voltage Range		±5.0			±5.0			V
Saturation Voltage	V _{IN} ≤ -5 mV, I _{OUT} = 50 mA V _{IN} ≤ -8 mV For LM306			1.0			1.0	V
								V
Saturation Voltage	V _{IN} ≤ -5 mV, I _{OUT} = 16 mA V _{IN} ≤ -8 mV For LM306			0.4			0.4	V
								V
Positive Output Level	V _{IN} ≥ 5 mV, I _{OUT} = -400μA V _{IN} ≥ 8 mV For LM306	2.5		5.5	2.5		5.5	V
Output Leakage Current	V _{IN} ≥ 5 mV, 8V ≤ V _{OUT} ≤ 24V V _{IN} ≥ 8 mV For LM306 T _L ≤ T _A ≤ 25°C 25°C < T _A ≤ T _H			1.0			2.0	μA
				100			100	μA
Strobe Current	V _{STROBE} = 0.4V		-1.7	-3.2		-1.7	-3.2	mA

Electrical Characteristics (Note 2) (Continued)

Parameter	Conditions	LM106/LM206			LM306			Units
		Min	Typ	Max	Min	Typ	Max	
Strobe "ON" Voltage		0.9	1.4		0.9	1.4		V
Strobe "OFF" Voltage	$I_{SINK} \leq 16 \text{ mA}$		1.4	2.2		1.4	2.2	V
Positive Supply Current	$V_{IN} = -5 \text{ mV}$ $V_{IN} = -8 \text{ mV}$ for LM306		5.5	10		5.5	10	mA
Negative Supply Current			-1.5	-3.6		-1.5	-3.6	mA

Note 1: The maximum junction temperature of LM106 is 150°C, LM206 is 110°C, LM306 is 85°C. For operating at elevated temperatures, devices in the HO8 package must be derated based on a thermal resistance of 170°C/W, junction to ambient, or 23°C/W, junction to case.

Note 2: These specifications apply for $-3\text{V} \geq V^- \geq -12\text{V}$, $V^+ = 12\text{V}$ and $T_A = 25^\circ\text{C}$ unless otherwise specified. All currents into device pins are considered positive.

Note 3: The offset voltages and offset currents given are the maximum values required to drive the output down to 0.5V or up to 4.4V (0.5V or up to 4.8V for the LM306). Thus, these parameters actually define an error band and take into account the worst-case effects of voltage gain, specified supply voltage variations, and common mode voltage variations.

Note 4: The response time specified (see definitions) is for a 100 mV input step with 5 mV overdrive.

Note 5: All currents into device pins are considered positive.

Note 6: Refer to RETS106X for LM106 military specifications.

Typical Applications**

Level Detector and Lamp Driver

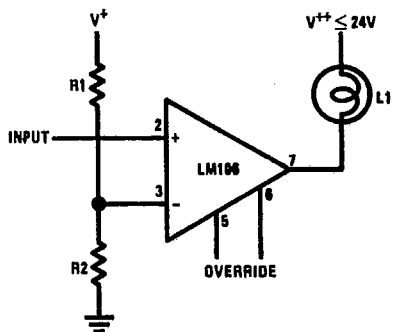

TL/H/7756-4

Fast Response Peak Detector

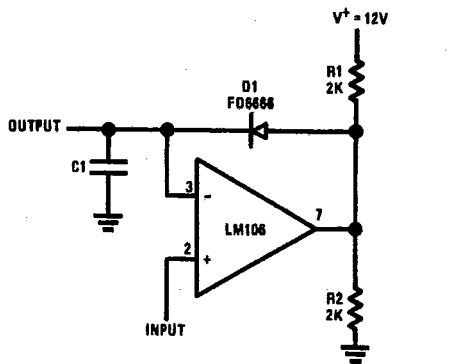

TL/H/7756-5

Relay Driver

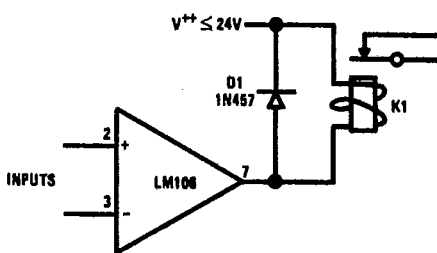

TL/H/7756-6

Adjustable Threshold Line Receiver

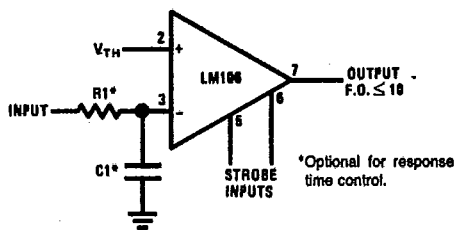

TL/H/7756-7

**Pin connections shown are for metal can package.

5

LM106/LM206/LM306

Typical Performance Characteristics

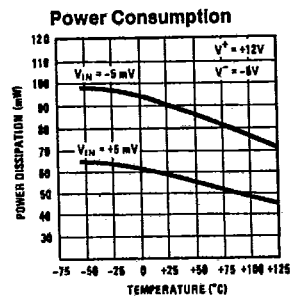
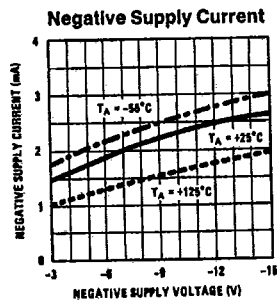
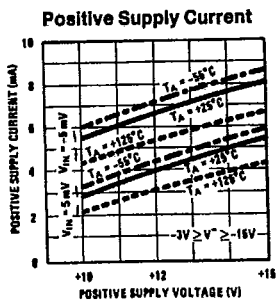
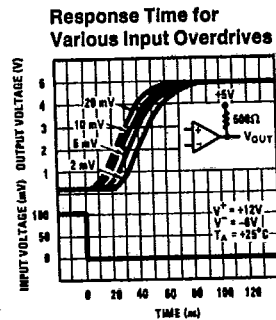
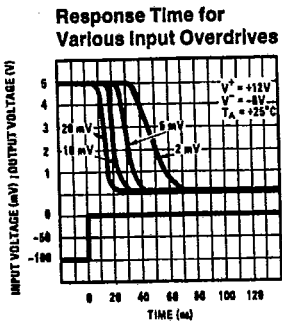
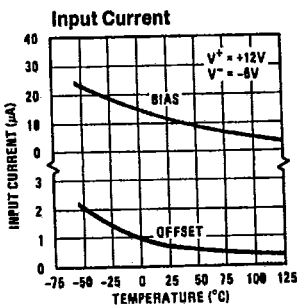
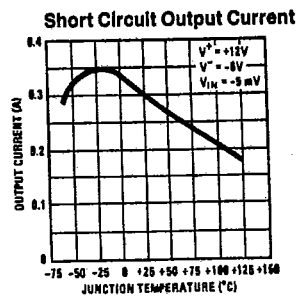
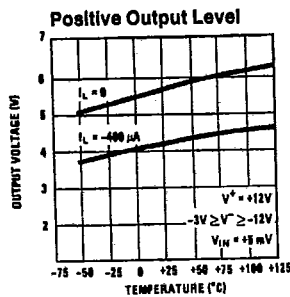
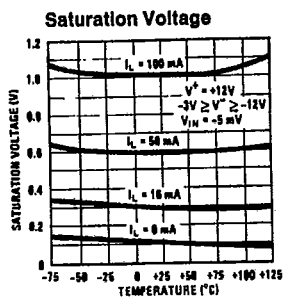
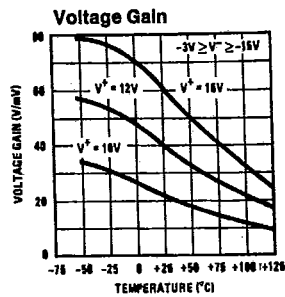
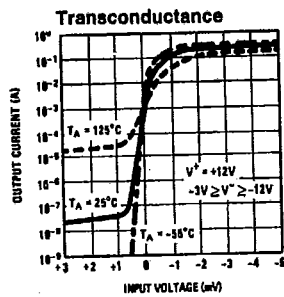
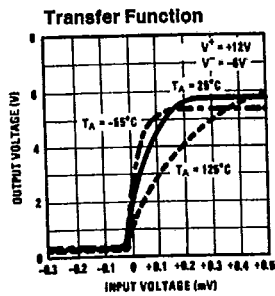

TL/H/7756-8