



LA7836

Vertical Deflection Output Circuit with Driver for TV Sets and Monitors

Overview

The LA7836 is an IC that contains the vertical deflection output circuit with a driver for color, B/W TV sets, monitors, and display units with a large aperture (maximum deflection current 2.2Ap-p) and is placed in an SIP13H package.

The LA7836 features fewer external parts and low power dissipation. Since both DC feedback and AC feedback can be provided inside the IC, it is easy to design the vertical deflection circuit.

The LA7836 can be used in conjunction with single-chip IC LA7650 series (NTSC), LA7680 series (PAL/NTSC) (VIF, SIF, video, chroma, and deflection circuit) to provide all the functions required for color TV signal processing.

Features

- Low power dissipation because of on-chip pump-up circuit.
- On-chip 50/60Hz vertical amplitude control circuit.
- On-chip ramp generator.
- On-chip driver circuit.
- Vertical output circuit.
- On-chip thermal protection circuit.
- Minimum number of external parts required.

Specifications

Maximum Ratings at $T_a = 25^\circ\text{C}$

Parameter	Symbol	Conditions	Ratings	Unit
Supply voltage for driver circuit	$+V_{CC1 \text{ max}}$		15	V
Supply voltage for pump-up circuit	$+V_{CC7 \text{ max}}$		30	V
Supply voltage for output circuit	$+V_{CC12 \text{ max}}$		62	V
Deflection output current	I_{DEF}		-1.5 to +1.5	Ap-o
Allowable power dissipation	$P_D \text{ max}$	With infinite heat sink	8	W
Operating temperature	T_{opr}		-20 to +85	$^\circ\text{C}$
Storage temperature	T_{stg}		-40 to +150	$^\circ\text{C}$
Thermal resistance	θ_{j-c}		4	$^\circ\text{C/W}$

Package Dimensions

unit:mm

3107-SIP13H

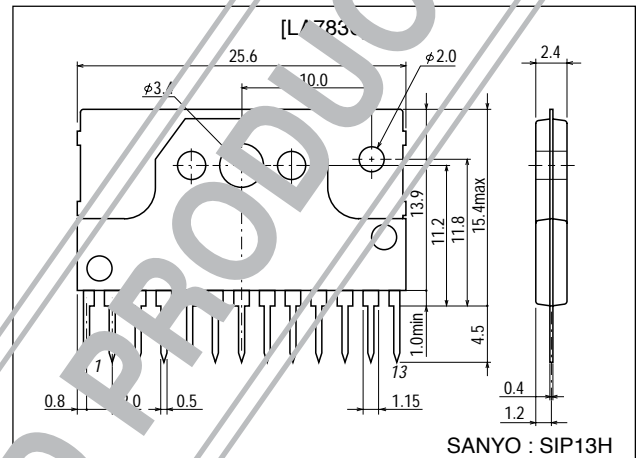

SANYO : SIP13H

■ Any and all SANYO products described or contained herein do not have specifications that can handle applications that require extremely high levels of reliability, such as life-support systems, aircraft's control systems, or other applications whose failure can be reasonably expected to result in serious physical and/or material damage. Consult with your SANYO representative nearest you before using any SANYO products described or contained herein in such applications.

■ SANYO assumes no responsibility for equipment failures that result from using products at values that exceed, even momentarily, rated values (such as maximum ratings, operating condition ranges, or other parameters) listed in products specifications of any and all SANYO products described or contained herein.

SANYO Electric Co.,Ltd. Semiconductor Company

TOKYO OFFICE Tokyo Bldg., 1-10, 1 Chome, Ueno, Taito-ku, TOKYO, 110-8534 JAPAN

Operating Supply Voltage Conditions

Parameter	Symbol	Conditions	Ratings	Unit
Supply voltage for driver circuit	+V _{CC1}		8 to 14	V
Supply voltage for pump-up circuit	+V _{CC7}		10 to 27	V

Recommended Operating Conditions

Parameter	Symbol	Conditions	Ratings	Unit
Supply voltage for driver circuit	+V _{CC1}		(9) 12	V
Supply voltage for pump-up circuit	+V _{CC7}		24	V
Deflection output current	I _{11p-p}		2.2 max	Ap-p

Operating Characteristics at Ta = 25°C, +V_{CC1}=12V, +V_{CC7}=24V

Parameter	Symbol	Conditions	Ratings			Unit
			min	typ	max	
Quiescent current in driver power supply	I _{CC1}		1.8	2.8	3.8	mA
Trigger input threshold voltage	V ₂		2.8	3.1	3.4	V
Voltage on vertical size control pin	V ₃		5.9	6.1	6.3	V
Ramp waveform shape start voltage	V _{RAM}		4.7	5.0	5.3	V
Pump-up charge saturation voltage	V _{S8-10}				1.5	V
Pump-up discharge saturation voltage	V _{S7-8}	I=1.1A			3.2	V
Deflection output saturation voltage (lower)	V _{S11-10}	I=1.1A			1.5	V
Deflection output saturation voltage (upper)	V _{S12-11}	I=1.1A			3.5	V
Idling current			16	22	32	mA
Voltage gain	V _{GO}	f=1kHz		59		dB

Pin Assignment and Block Diagram

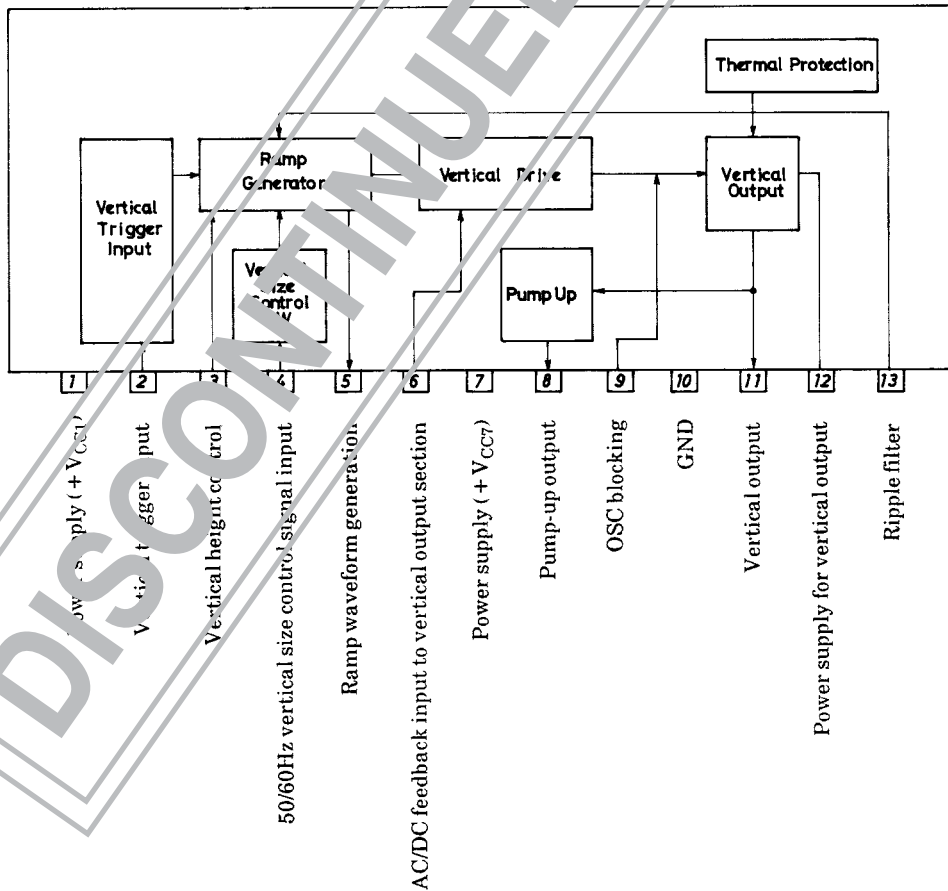

Interface Circuit

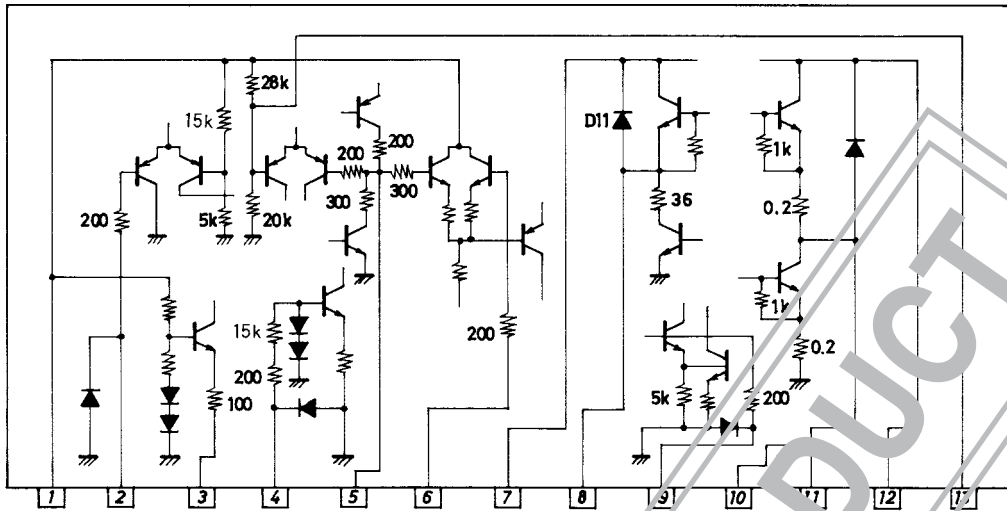

Sample Application Circuit

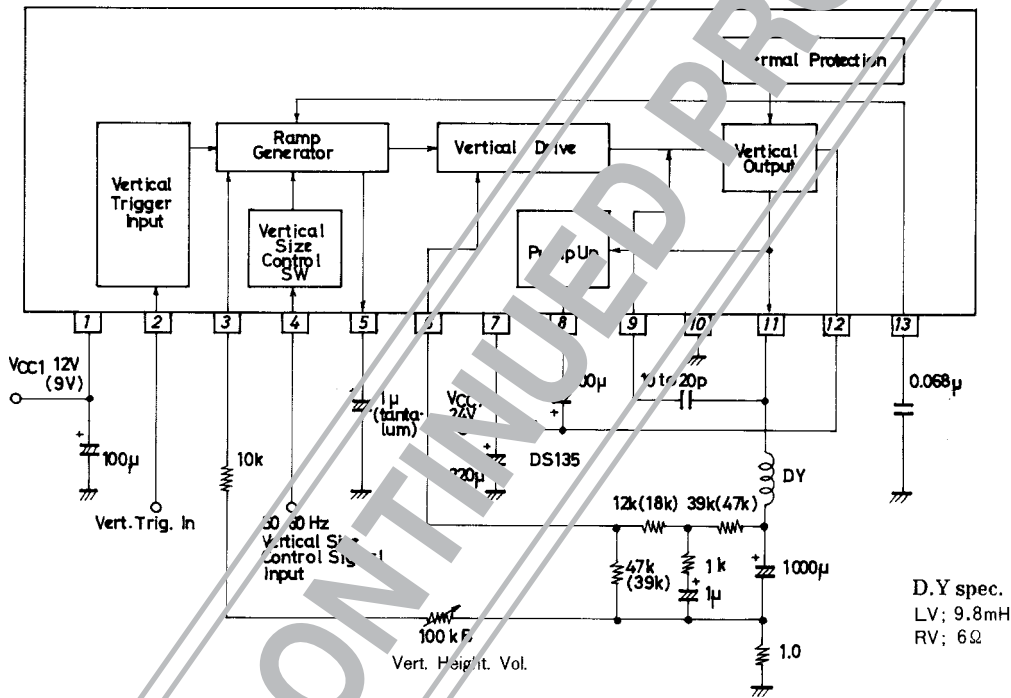

Unit (resistance:Ω, capacitance:F)

Note) The values in parentheses are for a sample application where the +VCC1 is 9V.

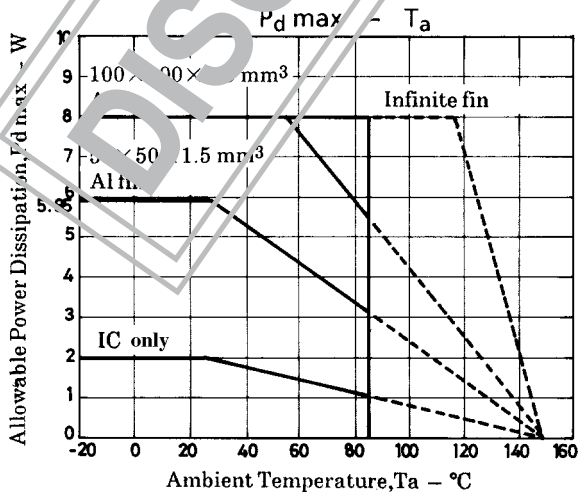

Proper Cares in Using the LA7836

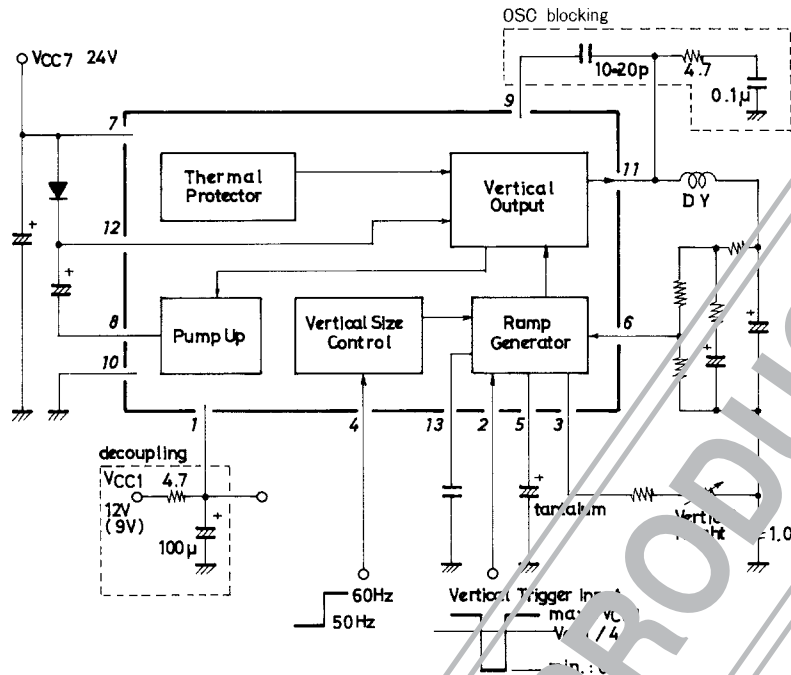

Unit (resistance:Ω, capacitance:F)

- Note 1) If horizontal components are mixed into pin 1, causing the interlace characteristic to worsen, provide decoupling as shown above. The resistor value and capacitor value are shown as an example.
- 2) If oscillation occurs, connect the OSC blocking circuit as shown above. However, if the deflection current increases, oscillation may not be blocked completely. In this case, change the application circuit as shown below.



- 3) In some applications, the OSC blocking capacitor across pins 9 and 11 is connected across pin 9 and GND.
- 4) The threshold voltage on pin 2 is $V_{CC1}/4$. Set the input trigger level so that it intersects this threshold level. The LA7836 operates on the negative transition of the trigger pulse.
- 5) Connect the radiator pin to GND.

DISCONTINUED PRODUCT

- DISCONTINUED PRODUCT**
- Specifications of any and all SANYO products described or contained herein stipulate the performance, characteristics, and functions of the described products in the independent state, and are not guarantees of the performance, characteristics, and functions of the described products as mounted in the customer's products or equipment. To verify symptoms and states that cannot be evaluated in an independent device, the customer should always evaluate and test devices mounted in the customer's products or equipment.
 - SANYO Electric Co., Ltd. strives to supply high-quality high-reliability products. However, any and all semiconductor products fail with some probability. It is possible that these probabilistic failures could give rise to accidents or events that could endanger human lives, that could give rise to smoke or fire, or that could cause damage to other property. When designing equipment, adopt safety measures so that these kinds of accidents or events cannot occur. Such measures include but are not limited to protective circuits and error prevention circuits for safe design, redundant design, and structural design.
 - In the event that any or all SANYO products (including technical data, services) described or contained herein are controlled under any of applicable local export control laws and regulations, such products must not be exported without obtaining the export license from the authorities concerned in accordance with the above law.
 - No part of this publication may be reproduced or transmitted in any form or by any means, electronic or mechanical, including photocopying and recording, or any information storage or retrieval system, or otherwise, without the prior written permission of SANYO Electric Co., Ltd.
 - Any and all information described or contained herein are subject to change without notice due to product/technology improvement, etc. When designing equipment, refer to the "Delivery Specification" for the SANYO product that you intend to use.
 - Information (including circuit diagrams and circuit parameters) herein is for example only; it is not guaranteed for volume production. SANYO believes information herein is accurate and reliable, but no guarantees are made or implied regarding its use or any infringements of intellectual property rights or other rights of third parties.

This catalog provides information as of January, 2001. Specifications and information herein are subject to change without notice.