

HS 9716/HS 9714 16/14-Bit Accurate S/H Amplifier

DESCRIPTION

The HS 9716 is a high accuracy sample/hold amplifier designed for use in high resolution data acquisition applications. Compensation networks include dielectric absorption compensation to 1/2 LSB at 16 bits making the HS 9716 suitable for use with true 16-Bit A/D converters such as the HS 9516. The HS 9714 is suitable for use with 16-Bit A/D converters with 14-Bit accuracy such as the HS 9576.

The HS 9716/HS 9714 comes complete with an internal hold capacitor and is available for use over the 0°C to 70°C temperature range and the -55°C to +125°C military temperature range. Full screening to MIL-STD-883C is available.

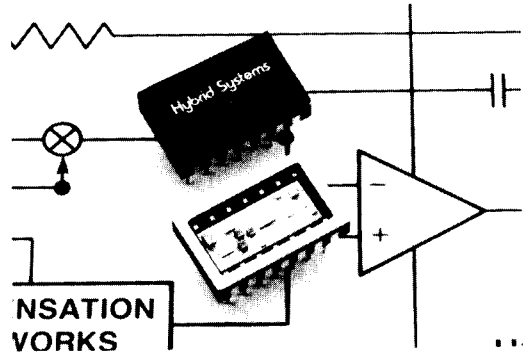

FEATURES

- 1** Dielectric Absorption Compensation to 1/2 LSB at 16-Bits
- 2** Droop Rate of 0.05 $\mu\text{V}/\mu\text{sec}$ at +25°C
- 3** Acquisition Time of 10 μsec max to 0.0008% of 20V (8 μsec max to 0.003%)
- 4** Hold Mode Feedthrough of -98 dB min (20 Vp-p, 20 kHz Signal)
- 5** Pin-For-Pin Compatible With AD389

BENEFITS

- 1** For Use with True 16-Bit A/Ds, such as HS 9516
- 2** Maintain 16-Bit Accuracy Over Extended Hold Period
- 3** For Use with High Speed, 14-, 16-Bit A/Ds
- 4** 16-Bit Accuracy Maintained Independent of Input Sinusoid
- 5** Improved Second Source Replacement

FUNCTIONAL DIAGRAM

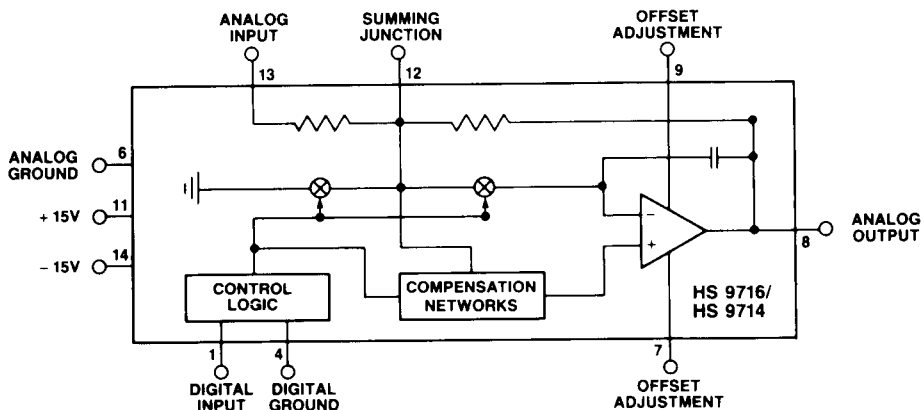

5

SPECIFICATIONS

(Typical @ +25°C and nominal power supply voltages unless otherwise noted)

MODEL	HS 9716K	HS 9716TB	HS 9714K	HS 9714TB
ANALOG INPUT				
Voltage Range	± 10V min	•	•	•
Overvoltage, No Damage	± 15V max	•	•	•
Input Impedance	10K Ω	•	•	•
DIGITAL INPUT				
Track Mode, Logic "1"	2 to 5.5V	•	•	•
Hold Mode, Logic "0"	0 to 0.8V	•	•	•
Logic "1" Current	5 μ A max	•	•	•
Logic "0" Current	5 μ A max	•	•	•
ANALOG OUTPUT				
Voltage	± 10V min	•	•	•
Current	2 mA min	•	•	•
Short Circuit Current	25 mA max	•	•	•
Impedance	0.035 Ω @ 1 kHz 12 Ω @ 1 MHz	•	•	•
DC ACCURACY/STABILITY				
Gain	- 1.00 V/V	•	•	•
Gain Error	± 0.02% max	•	± 0.03% max	± 0.03% max
Gain Nonlinearity (± 10V Output Track)	± 0.0005%	•	± 0.001%	± 0.001%
Gain Drift	5 ppm/°C max	•	•	•
Offset ¹	± 30 mV max	•	•	•
Output Offset @ T _{min} , T _{max} (Track)	± 1 mV	•	•	•
TRACK (SAMPLE) MODE DYNAMICS				
Frequency Response		•	•	•
Small Signal (- 3 dB)	1 MHz min	•	•	•
Full Power Bandwidth	0.2 MHz	•	•	•
Slew Rate	10V/ μ sec	•	•	•
Noise in Track Mode, DC to 1.0 MHz	50 μ Vrms	•	50 μ Vrms	50 μ Vrms
TRACK (SAMPLE)-TO-HOLD SWITCHING				
Aperture Delay	10 nsec	•	•	•
Aperture Uncertainty	100 psec	•	•	•
Offset Step (Pedestal)	± 2 mV	•	•	•
Switching Transient		•	•	•
Amplitude	50 mV	•	•	•
Settling to 1 mV	0.5 μ sec	•	•	•
Settling to 0.3 mV	1 μ sec max	•	•	•
Dielectric Absorption	7.5 μ V/V max	•	15 μ V/V max	15 μ V/V max
HOLD MODE DYNAMICS				
Droop Rate	0.05 μ V/ μ sec max	•	0.1 μ V/ μ sec max	0.1 μ V/ μ sec max
Droop Rate at T _{max}	10 μ V/ μ sec max	•	•	•
Feedthrough Rejection (20 Vp-p @ 20 kHz)	98 dB min	•	90 dB min	90 dB min
(20 Vp-p @ 200 kHz)	90 dB min	•	86 dB min	86 dB min
Noise in Hold	25 μ Vrms	•	•	•
HOLD-TO-TRACK (SAMPLE) DYNAMICS				
Acquisition Time to ± 0.0008% of 20V	5 μ sec typ, 10 μ sec max over temp	•	N/A	N/A
Acquisition Time to ± 0.003% of 20V	4 μ sec typ, 7.5 μ sec max over temp	•	•	•
POWER REQUIREMENTS				
Nominal Voltages for Rated Performance	± 15V (± 3%) ²	•	•	•
Supply Current		•	•	•
+V _S	10 mA, 20 mA max	•	•	•
-V _S	10 mA, 18 mA max	•	•	•
Power Dissipation	300 mW, 500 mW max	•	•	•
Power Supply Rejection	100 μ V/V max	•	•	•
TEMPERATURE RANGE				
Operating	0°C to +70°C	55°C to +125°C	0°C to +70°C	-55°C to +125°C
Storage	-40°C to +85°C	65°C to +155°C	-40°C to +85°C	-65°C to +155°C
PACKAGE				
14-Pin Single DIP Ceramic				
Junction to Air, θ_{JA} (free air)	35°C/W	•	•	•
Junction to Case, θ_{JC}	10°C/W	•	•	•

NOTES:

- Adjustable to zero
- ± 5V to ± 18V operating for operating to derated performance
- * Same as 9716K specification

PACKAGE OUTLINE

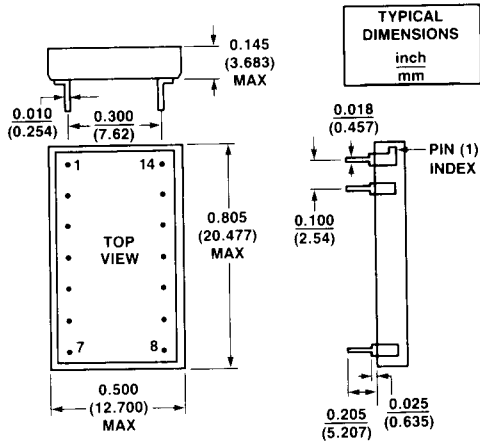

Pin 1 is marked by a dot on the top of the package.

PIN ASSIGNMENTS

PIN	FUNCTION	PIN	FUNCTION
1	DIGITAL INPUT	14	-15V
2	NC	13	ANALOG INPUT
3	NC	12	SUMMING JUNCTION
4	DIGITAL GROUND	11	+15V
5	NC	10	NC
6	ANALOG GROUND	9	OFFSET ADJUSTMENT
7	OFFSET ADJUSTMENT	8	ANALOG OUTPUT

NC - No internal connection

ABSOLUTE MAXIMUM RATINGS

(Referenced to Grnd)
(Exceeding any one of these parameter may cause permanent damage to the unit.)

Voltage Between +V _s and -V _s Terminals	±36V
Input Voltage	Actual Supply Voltage
Digital Input Voltage	-0.5V to +5.5V
Output Current, Continuous	±40 mA
Internal Power Dissipation	650 mW
Storage Temperature Range	-65°C to +150°C
Output Short-Circuit Duration	Indefinite
Lead Temperature (Soldering, 10 secs)	+300°C

OPERATING INSTRUCTIONS

OFFSET ADJUST

In most data acquisition systems only one offset adjustment is made. Usually, the offset adjust of the ADC is used to cancel all other accumulated system offsets. The offset of the HS 9716/9714 can be nulled by means of a 5k Ω to 25k Ω potentiometer between pins 7, 9, and 11. If the offset of the HS 9716/9714 is not adjusted, then connect pins 7 and 9 to pin 14, the

negative supply. Otherwise, the high impedance of the null pin together with parasitic capacitances can cause tail effects.

SAMPLE/HOLD CONTROL

A TTL logic "1" applied to pin 1 switches the HS 9716/9714 into the track (sample) mode. In this mode, the device acts as an amplifier which exhibits normal operational amplifier behavior. Application of a logic "0" to pin 1 switches the HS 9716/9714 into the hold mode, with the output voltage held constant at the value present when the hold command is given.

INSTALLATION

GROUNDING

The HS 9716 is a true 16-Bit performance sample/hold amplifier. Grounding of this component, as with any 16-Bit component, must be done with care for full performance. The analog ground (pin 6) is isolated from the digital ground (pin 4) in order to allow for isolation of digital and signal path ground currents. A low noise grounding circuit is shown in Figure 1. Notice that the logic grounds return to the +5V supply on a wire separate from the wire providing a logic return for the A/D converter. Also notice that only analog grounds directly in the signal path are joined together with the A/D converter analog ground. The result of this is that the signal path ground remains quiet to < 1LSB (150 μ V) and full performance is obtained.

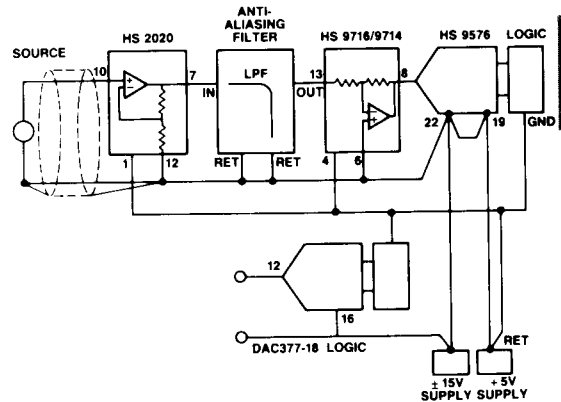

Figure 1. Basic Grounding Practice

DECOUPLING

Internal 0.01 μ F power supply bypass capacitors are included in the HS 9716/9714 to maintain device stability. If the supply voltages contain excessive high frequency noise, additional external high frequency capacitors may be necessary to maintain low noise performance.

DISCUSSION OF SPECIFICATIONS

TERMINOLOGY

Sample/Hold Amplifier is actually a more common name for what really is a track/hold (T/H) amplifier. A true S/H amplifier normally spends most of its time in the hold mode. When commanded to the sample mode, it will take a very fast sample and immediately go back into the hold mode. A true T/H amplifier can track the input indefinitely and it can be in the hold mode indefinitely. In practice, most S/H amplifiers manufactured today are actually T/H amplifiers. This is why the HS 9716/9714 data sheet specifies track (sample) in many places.

Acquisition Time is the time required by the device to "switch" from the hold mode to the track (sample) mode. This time is measured between the application of a "track" command and the point at which the output has settled to within a specified error band. This time includes the switch delay time, slewing time and settling time for a given output voltage change.

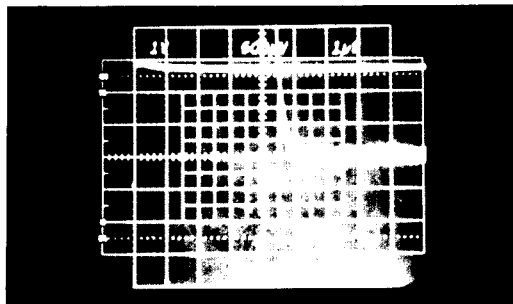

Acquisition Time of a Worst Case 20V Step (Plus to Minus Input)
Top trace shows hold command going high in the second horizontal division. Lower trace shows output settling to a 500 μ V/div. scale.

Switching Transient Settling (Hold Mode Settling) is the time required for the device to stabilize in the hold mode to within specified limits of its final value after the hold mode signal has been given.

Aperture Delay is the time lag between the application of the "hold" command and the instant the output stops tracking the input. It consists primarily of the propagation delay of the switch driver. Since it is a known quantity, the "hold" command can be advanced to account for this delay.

Aperture Uncertainty (Jitter) is the variation in the aperture delay from sample to sample. This time uncertainty produces a voltage uncertainty proportional to the input slew rate.

Offset Step (Pedestal) is a track (sample)-to-hold offset that results from unequal charge transfers when the device is switched into the hold mode.

Feedthrough is the amount of analog input signal that is coupled through to the analog output while the circuit is in the hold mode. It is usually expressed as a ratio in dB's. Since feedthrough increases with frequency, it should be specified at a given frequency.

Droop Rate is the rate of change in output voltage over time while in the hold mode. The droop rate will determine how long a signal can be accurately held before it

changes more than 1 LSB. This, in turn, determines the maximum conversion time that an A/D converter can have to be used with a particular S/H.

Full Power Bandwidth is the frequency at which a full scale input/output sine wave becomes slew rate limited to -3 dB.

Small Signal Bandwidth is the maximum analog signal frequency that can be tracked before the gain is reduced by 3 dB. This assumes the signal amplitude is small enough so as not to be slew rate limited.

Dielectric Absorption is the long term polarization of the dielectric material in the hold capacitor. This polarization changes the electric field strength in the capacitor producing a long term voltage error or "memory."

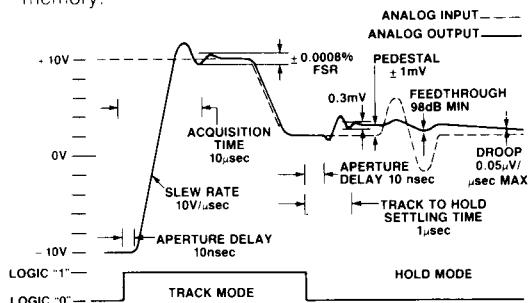

Figure 2. Pictorial Showing Various S/H Characteristics

KEY SPECIFICATIONS DETERMINING 16-BIT ACCURACY

The key specifications of the HS 9716 which support its accuracy to 16 bits are listed below.

- Gain Nonlinearity** — For a ± 10 V output range, gain nonlinearity is $\pm 0.0005\%$ which is less than $1/2$ LSB at 16 bits (0.0008%).
- Noise in Track Mode** — For a noise bandwidth between DC and 1 MHz, the noise is specified at 20μ V rms. Since $1/2$ LSB at 16 bits is 150μ V (FSR = 20V), the noise level is well below that required for 16-Bit accuracy.
- Droop** — The droop rate is specified at 0.05μ V/ μ sec max. For a 150μ V change ($1/2$ LSB, 16 bits, FSR = 20V), this S/H can accurately hold a signal for 3000 μ sec, or 3 milliseconds. This makes it ideal for use with 16-Bit integrating A/Ds. The droop rate at $+125^\circ\text{C}$ is specified at 10μ V/ μ sec max. Thus, for a 150μ V change ($1/2$ LSB at 16 bits), the HS 9716 can accurately hold a signal for 15μ sec at $+125^\circ\text{C}$.
- Dielectric Absorption** — This is specified at 7.5μ V/V max. For a 20V input change which must be stored by the hold capacitor, the change in the stored voltage will be 150μ V max, or $1/2$ LSB at 16 bits.
- Acquisition Time** — This is specified as 10μ sec max settling to $\pm 0.0008\%$ of 20V, or $1/2$ LSB at 16 bits.
- Feedthrough** — Feedthrough rejection is specified at 98 dB min for a 20V p-p, 20 kHz input signal. This means that the hold mode output will move no more than 98 dB less than the input. For a ± 10 V input, this is $\pm 125 \mu$ V which is less than $1/2$ LSB at 16 bits.

DISCUSSION OF DIELECTRIC ABSORPTION

Dielectric absorption (D.A.) is often the biggest error source in a sample and hold or track/hold amplifier. D.A. is caused by either the rotation of polar molecules in a polar dielectric such as tantalum pentoxide, producing an error as big as 8%, or it is caused by slight distortions in the electron fields of molecules in a non-polar dielectric such as polystyrene, producing errors only as big as 0.04%.

Worst case dielectric absorption can be measured with a standard test. This test involves charging a capacitor for a period longer than T_{Max} (50ms), discharging it for a period shorter than T_{Min} (100 μ s) and observing the open circuit voltage for a period longer than T_{Max} (50ms). This assures that all of the molecules in the dielectric are completely polarized before the charge on the capacitor plates is removed with enough speed that the polarizations are not neutralized. Obviously, if the application involves sample and hold times which

are less extreme, then the dielectric absorption error will be less severe.

These molecular distortions and polarizations exhibit multiple exponential decays which may be modeled by adding series R-C networks in parallel with the hold capacitor with time constants ranging from 100 microseconds to 50 milliseconds. In the HS 9716/14, these multiple time constants are carefully matched and compensated to below 0.00075%/0.0015%. As can be seen in the absorption sag/sample time graph, even teflon capacitors exhibit absorption errors as large as 0.01% for a 10 microsecond sample time. Thus the HS 9716 is a substantial improvement from conventional sample and hold or track/hold amplifiers using the lowest dielectric absorption capacitors available. The two different hold mode oscilloscope photographs show how the HS 9716 hold capacitor dielectric absorption behaves without and with the compensation circuit connected.

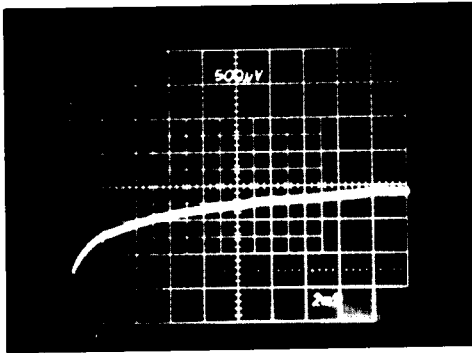

Hold Mode Dielectric Absorption Sag For 5 μ sec Sample Period Without Dielectric Absorption Compensation

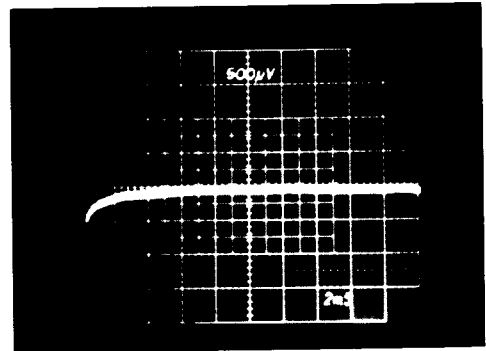

Hold Mode Dielectric Absorption Sag For 5 μ sec Sample Period With Dielectric Absorption Compensation

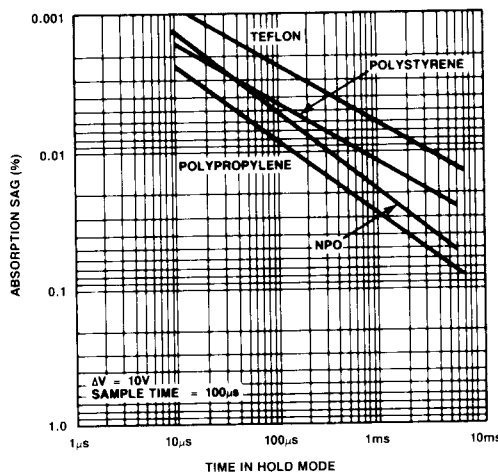

Capacitor Dielectric Absorption

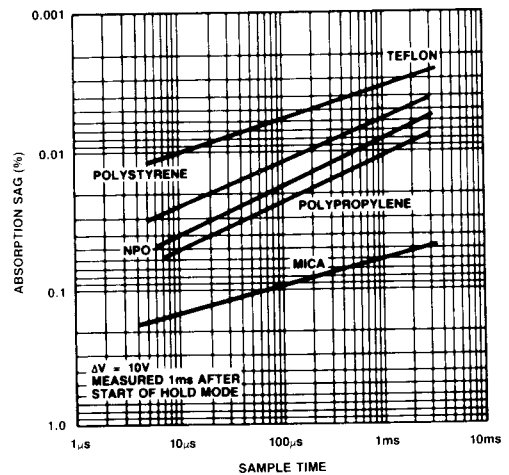

Capacitor Dielectric Absorption

APPLICATIONS

DIGITIZING DYNAMIC SIGNALS

Sample/hold amplifiers are normally used in front of A/D converters to hold the input voltage constant during conversion. Digitizing errors will result if the analog input signal varies by more than 1/2 LSB during conversion. In the case of the HS 9576, a 16-Bit A/D with a conversion time of 15 μ sec to 14 bits, this results in a low input frequency which can be accurately digitized as explained below:

For a sine wave input, its maximum rate of change is calculated as $2\pi Af$ where f = frequency and A = amplitude. If one allows a 1/2 LSB change (0.6mV) during conversion for a $\pm 10V$ input swing to the A/D converter, the maximum rate of change limit would be 0.6mV/15 μ sec, or 0.04mV/ μ sec. Thus, the maximum sine wave input frequency that can be accurately digitized is calculated as:

$$0.04\text{mV}/\mu\text{sec} = 2\pi Af$$

For a $\pm 10V$ input sine wave, this frequency limit is 0.63 Hz.

Expressed differently, the full scale bandwidth of the HS 9576 is slew rate limited to 0.63 Hz. By using a S/H, such as the HS 9716/9714 in front of the A/D (ref.

Fig. 1), this bandwidth can be significantly increased. The S/H will "freeze" an input signal that is changing too rapidly for the A/D alone to handle and hold it constant while the A/D performs a conversion. A S/H can accurately "freeze" signals moving as fast as 1/2 LSB during its aperture uncertainty of 100 psec. Thus, for use with the HS 9576 to 14-Bit accuracy, the maximum rate of change limit would be 0.6mV (1/2 LSB, 14 bits, $\pm 10V$ swing) during 100 psec, or 6V/ μ sec, which is within the slew limit of the HS 9716/9714 (10V/ μ sec). Thus, the maximum full scale input frequency that can be accurately digitized is calculated as:

$$6V/\mu\text{sec} = 2\pi Af$$

For a $\pm 10V$ full scale input, this frequency limit is 95 kHz. Expressed differently, the slew rate limited full

scale bandwidth of the HS 9576 has now been increased to 95 kHz with the use of the HS 9716/9714 S/H.

Throughput and the Nyquist criteria are other factors which will determine the highest input signal frequency that can be sampled. For the combination of the HS 9576 and the HS 9716/9714, the throughput is related to the sum of the conversion time of the A/D (15 μ sec), the acquisition time of the S/H (5 μ sec) and the hold mode (switching transient) settling time of the S/H (1 μ sec). The total of 21 μ sec represents a throughput of 47.6 kHz. Based on the Nyquist criteria of sampling more than twice per cycle, the highest input signal frequency that can be accurately digitized is slightly less than 23.8 kHz.

OVERSAMPLING/UNDERSAMPLING

Oversampling is a technique where, for example, two samples are averaged to provide twice the resolution at half the bandwidth. The HS 9716 is well suited for this since its low noise of 20 μ V rms produces a dynamic range of 7.14 V rms (rms equivalent of 20 Vp-p sine wave) divided by 20 μ V rms, or 110 dB. This is equivalent to 18 bits of resolution.

Undersampling is a bandpass technique where one can sample a frequency higher than the Nyquist frequency. This is accomplished by bandpass filtering the input so that the bandwidth is less than the Nyquist frequency. The HS 9716 is well suited for this due to its large small signal bandwidth (1 MHz) and low aperture uncertainty (100 psec).

ORDERING INFORMATION

MODEL	DIELECTRIC ABSORPTION	TEMPERATURE RANGE
HS 9716K	7.5 μ V/V	0°C to +70°C
HS 9714K	15 μ V/V	0°C to +70°C
HS 9716TB	7.5 μ V/V	-55°C to +125°C
HS 9714TB	15 μ V/V	-55°C to +125°C

Specifications subject to change without notice.