

# Up to 950 mW Fiber Bragg Grating Stabilized 980 nm Pump Modules

S31 Series

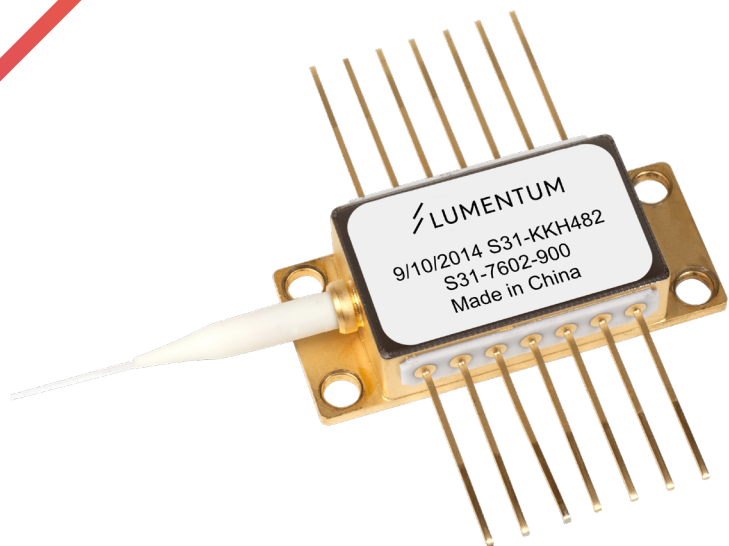

The Lumentum S31 Series pump laser module's revolutionary design and lean manufacturing processes significantly advance the 980 nm pumps' performance and scalability. It meets the telecommunications industry's stringent requirements, including Telcordia GR-468-CORE for hermetic 980 nm pump modules.

The S31 Series pump module, which uses fiber Bragg grating stabilization to lock the emission wavelength, provides a noise-free, narrowband spectrum, even under temperature, drive current, and optical feedback changes. Wavelength selection is available for applications requiring the highest spectrum control performance with the highest power available.

#### **Key Features**

- Operating power range from 600 to 950 mW
- 25°C internal temperature, compatible with legacy temperature control
- Low-profile 14-PIN butterfly package
- Fiber Bragg grating stabilization
- Wavelength selection available
- Integrated thermoelectric cooler, thermistor, and monitor diode
- High dynamic range
- Excellent low-power stability

#### **Applications**

- Dense wavelength division multiplexing (DWDM) EDFAs for small package designs
- High-bit-rate, high channel-count EDFAs
- CATV distribution

#### **Compliance**

- Telcordia GR-468-CORE

Dimensions Diagram

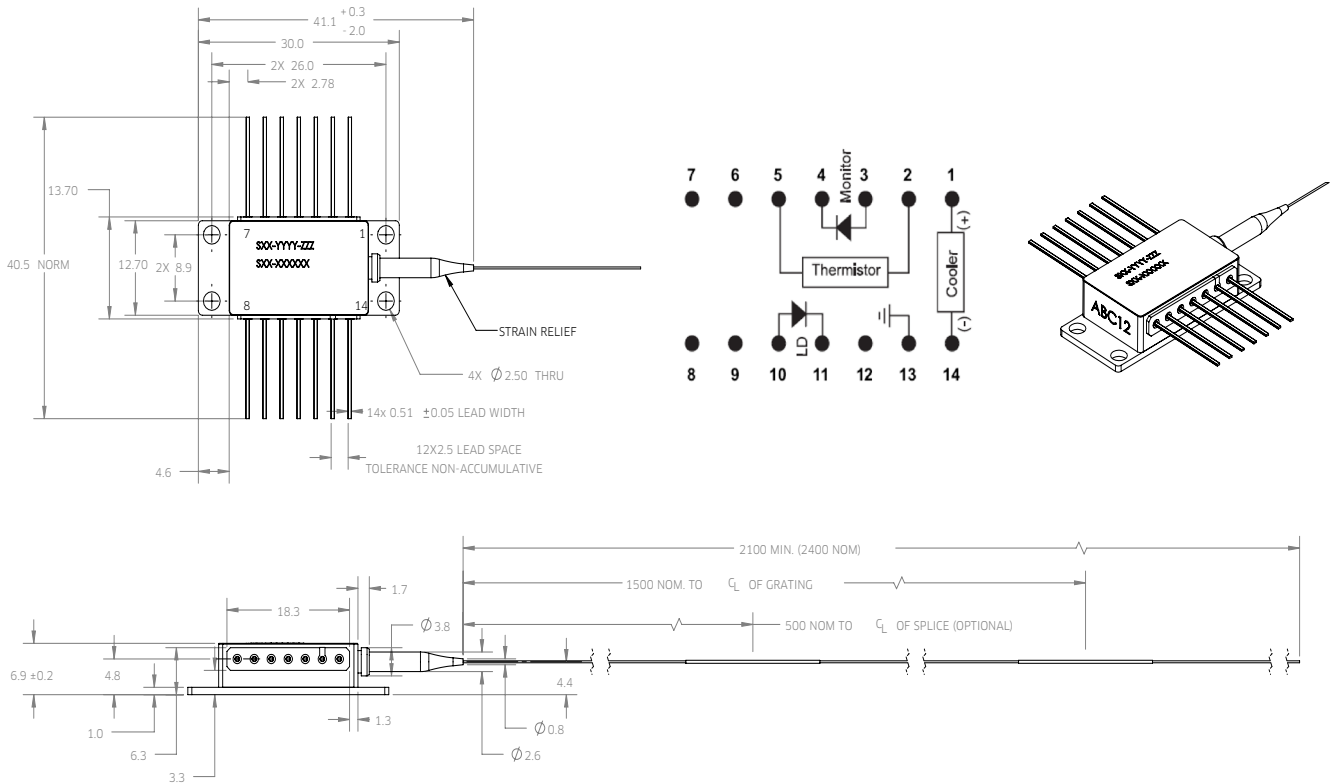

Pin Assignments

Pin	Description
1	Cooler (+)
2	Thermistor
3	Monitor PD anode
4	Monitor PD cathode
5	Thermistor
6	N/C
7	N/C
8	N/C
9	N/C
10	Laser anode
11	Laser cathode
12	N/C
13	Case ground
14	Cooler (-)

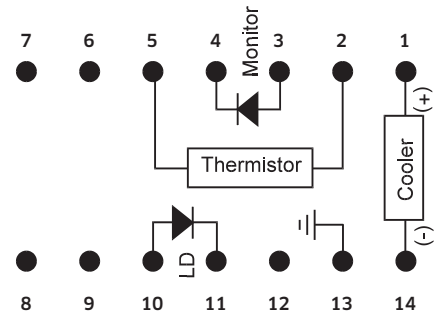

**Table 1 Absolute Maximum Ratings**

Parameter	Symbol	Test Condition	Minimum	Maximum
Operating case temperature	$T_{op}$		-5°C	75°C
Storage temperature	$T_{stg}$	2000 hr	-40°C	85°C
Laser operating temperature	$T_{LD}$		-5°C	50°C
LD reverse voltage	$V_f$		-	1.2 V
LD forward current	$I_{f,max}$		-	1900 mA
LD reverse current			-	10 $\mu$ A
PD reverse voltage	$V_{PD}$		-	20 V
PD forward current	$I_{PF}$		-	10 mA
LD electrostatic discharge (ESD)	$V_{ESD,LD}$	C = 100 pF, R = 1.5 k $\Omega$ , HBM		1000 V
PD electrostatic discharge (ESD)	$V_{ESD,PD}$	C = 100 pF, R = 1.5 k $\Omega$ , HBM		500 V
TEC current	$I_{TEC}$		-1.0 A	4.0 A
TEC voltage	$V_{TEC}$		-	4.5 V
Axial pull force		3 x 10 s	-	5 N
Side pull force		3 x 10 s	-	2.5 N
Fiber bend radius			16 mm	-
Relative humidity	RH	Noncondensing	5%	95%
Lead soldering time		300°C	-	10 s

Absolute maximum ratings are the maximum stresses that may be applied to the module for short periods of time without causing damage. Stresses in excess of the absolute maximum ratings can cause permanent damage to the device. Exposure to absolute maximum ratings for extended periods of time or exposure to more than one absolute maximum rating simultaneously may adversely affect device reliability. Specifications may not necessarily be met under these conditions.

**Table 2 Operating Parameters<sup>1</sup>**

Fill in the xxxx with the suitable 4-digit wavelength code shown in Table 3.

Product Code	Maximum Operating Power $P_{op}$ (mW)	Maximum Operating Current $I_{op}$ (mA)	Minimum Kink-Free Power $P_{max}$ (mW)	Maximum Kink-Free Current $I_{max}$ (mA)
S31-xxxx-600	600	1390	660	1500
S31-xxxx-620	620	1410	680	1530
S31-xxxx-640	640	1430	705	1555
S31-xxxx-660	660	1450	725	1580
S31-xxxx-680	680	1470	750	1605
S31-xxxx-700	700	1490	770	1635
S31-xxxx-720	720	1510	790	1660
S31-xxxx-740	740	1530	815	1685
S31-xxxx-760	760	1550	835	1710
S31-xxxx-780	780	1570	860	1740
S31-xxxx-800	800	1590	880	1765
S31-xxxx-820	820	1610	900	1790
S31-xxxx-840	840	1625	925	1815
S31-xxxx-850	850	1645	935	1840
S31-xxxx-860	860	1665	945	1870
S31-xxxx-880	880	1675	970	1880
S31-xxxx-900	900	1675	990	1880
S31-xxxx-950	950	1675	1045	1880

1. BOL,  $T_{case}$  = -5 to 75°C, -50 dB reflection, unless noted otherwise

**Table 3 Available Peak Wavelength Selection**

Fill in the yyy with the maximum operating power shown in Table 2.

Product Code	Minimum Center Wavelength	Maximum Center Wavelength
S31-7402-yyy	973.0 nm	975.0 nm
S31-7602-yyy	975.0 nm	977.0 nm
S31-8000-yyy	973.0 nm	981.5 nm

**Table 4 Electro-Optical Performance<sup>1</sup>**

Parameter	Symbol	Test Condition	Minimum	Maximum
Threshold current	$I_{th-BOL}$		–	110 mA
Forward voltage	$V_f$	$I_f = I_{op}$	–	2.6 V
Fiber output power range	$P_f$		30 mW	$P_{op}$
Pump power in band	$P_{pump}$	Pump band = $\lambda_m \pm 1.5$ nm, at $P_{op}$	90%	
Spectral width	$\Delta\lambda_{RMS}$	Over $P_f$ range		2.0 nm
Wavelength tuning vs. temperature	$\Delta\lambda/T$	$I_f = I_{op}$	–	0.01 nm/°C
Optical power stability	$\Delta P_{f,t}$	Over $P_f$ range, DC to 50 kHz, 30 mW – 50 mW	–	5.0%
		Over $P_f$ range, DC to 50 kHz, 50 mW – $P_{op}$	–	2.0%
Tracking ratio <sup>2</sup>	TR	$0.1P_{op} < P_f < P_{op}$	0.52	1.48
Tracking error <sup>3</sup>	TE	$P_{op}$	–48%	48%
Monitor diode responsivity	$I_{BF}$	At $P_{op}$	0.5 $\mu$ A/mW	5 $\mu$ A/mW
Thermistor resistance	$R_{th}$	$T_{set} = 25^\circ\text{C}$	9.5 k $\Omega$	10.5 k $\Omega$
		$T_{set} = 45^\circ\text{C}$	4.1 k $\Omega$	4.6 k $\Omega$

1. BOL,  $T_{case} = -5^\circ\text{C}$  to  $75^\circ\text{C}$ ,  $P_f = 30$  mW to  $P_{max}$ , –50 dB reflection, MPD with –5 V bias, unless otherwise noted

2. The tracking ratio is a measure of the front-to-back tracking when the output power is varied. On a plot of optical power versus back-face photocurrent, a straight line is drawn between the minimum power (30 mW) and the operating power ( $P_{op}$ ) points. The tracking ratio is defined as the ratio between measured optical power (shown as data points on the plot) to the value derived from the straight line.

3. The tracking error is defined as the normalized change of output power relative to  $P_f$  at  $25^\circ\text{C}$ , that is,  $(P_f - P_{f,25})/P_{f,25}$ , over case temperature range of 0 to  $75^\circ\text{C}$ , at constant back face monitor current corresponding to the lowest back face monitor current at  $P_f = P_{op}$  of  $0^\circ\text{C}$ ,  $25^\circ\text{C}$ ,  $75^\circ\text{C}$ .

**Table 5** TEC and Total Module Power Consumption<sup>1</sup>

Product Code	TEC Current $I_{\max}$ (A)	TEC Voltage $V_{\max}$ (V)	TEC Power Consumption $P_{\text{TEC}}$ (W)	Total Module Power Consumption $P_{\max}$ (W)
S31-xxxx-600	2.28	2.87	6.54	9.69
S31-xxxx-620	2.30	2.88	6.62	9.83
S31-xxxx-640	2.31	2.90	6.70	9.98
S31-xxxx-660	2.33	2.92	6.80	10.13
S31-xxxx-680	2.35	2.94	6.89	10.28
S31-xxxx-700	2.36	2.95	6.99	10.44
S31-xxxx-720	2.38	2.97	7.08	10.59
S31-xxxx-740	2.40	2.99	7.19	10.76
S31-xxxx-760	2.42	3.01	7.27	10.91
S31-xxxx-780	2.44	3.03	7.40	11.10
S31-xxxx-800	2.46	3.05	7.53	11.30
S31-xxxx-820	2.49	3.08	7.65	11.49
S31-xxxx-840	2.50	3.09	7.74	11.63
S31-xxxx-850	2.53	3.11	7.87	11.82
S31-xxxx-860	2.55	3.14	8.00	12.01
S31-xxxx-880	2.60	3.18	8.27	12.34
S31-xxxx-900	2.65	3.23	8.56	12.67
S31-xxxx-950	2.65	3.23	8.56	12.67

1. (BOL,  $\Delta T = 50^\circ\text{C}$ ,  $T_{\text{case}} = 75^\circ\text{C}$ ,  $T_{\text{LD}} = 25^\circ\text{C}$ )

**Table 6** HI 1060 Fiber Nominal Characteristics and Tolerances

Parameters	Specification
Cutoff wavelength	920 nm
Maximum attenuation at 980 nm	2.1 dB/km
Cladding outside diameter	125 $\pm$ 1 $\mu\text{m}$
Coating outside diameter	245 $\pm$ 10 $\mu\text{m}$
Core-cladding concentricity	$\leq$ 0.5 $\mu\text{m}$
Mode field diameter	5.9 $\pm$ 0.3 $\mu\text{m}$

Note:

PM fiber option is available upon request.

## User Safety

### Safety and Operating Considerations

The laser light emitted from this laser diode is invisible and may be harmful to the human eye. Avoid looking directly into the fiber when the device is in operation.

CAUTION: THE USE OF OPTICAL INSTRUMENTS WITH THIS PRODUCT INCREASES EYE HAZARD.

Operating the laser diode outside of its maximum ratings may cause device failure or a safety hazard. Power supplies used with this component cannot exceed maximum peak optical power.

CW laser diodes may be damaged by excessive drive current or switching transients. When using power supplies, the laser diode should be connected with the main power on and the output voltage at zero. The current should be increased slowly while monitoring the laser diode output power and the drive current. Careful attention to heat sinking and proper mounting of this device is required to ensure specified performance over its operating life. To maximize thermal transfer to the heat sink, the heat sink mounting surface must be flat to within .001 inch and the mounting screws must be torqued down to 1.5 in.-lb.

ESD PROTECTION—Electrostatic discharge (ESD) is the primary cause of unexpected laser diode failure. Take extreme precaution to prevent ESD. Use wrist straps, grounded work surfaces, and rigorous antistatic techniques when handling laser diodes.

## Labeling

### Laser Safety

The Lumentum pump laser module emits hazardous invisible laser radiation.

Due to the small size of the pump module, the box packaging is labeled with the laser radiation hazard symbol and safety warning labels shown



14-pin module label



Shipping box label



Output power and laser emission indicator label

### Ordering Information

For more information on this or other products and their availability, please contact your local Lumentum account manager or Lumentum directly at [customer.service@lumentum.com](mailto:customer.service@lumentum.com)

Telcordia is a registered trademark of Telcordia Technologies Incorporated.

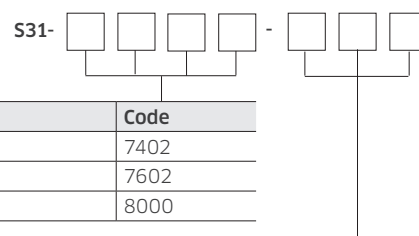

Peak Wavelength	Code
973.0 to 975.0 nm	7402
975.0 to 977.0 nm	7602
973.0 to 981.5 nm	8000

Maximum Operating Power	Code
600 mW	600
620 mW	620
640 mW	640
660 mW	660
680 mW	680
700 mW	700
720 mW	720
740 mW	740
760 mW	760
780 mW	780
800 mW	800
820 mW	820
840 mW	840
860 mW	860
880 mW	880
900 mW	900
950 mW	950



North America  
Toll Free: 844 810 LITE (5483)

Outside North America  
Toll Free: 800 000 LITE (5483)

China  
Toll Free: 400 120 LITE (5483)

© 2018 Lumentum Operations LLC  
Product specifications and descriptions in this document are subject to change without notice.