

MGBC-20-6-X-X Optical Fibre Channel Gigabit Interface Converter (GBIC)



Features

- Compliant with Gigabit Interface Converter (GBIC) specification
- Compliant With ANSI X3T11 Fibre Channel specification for optical links
- 75Ω AC coupled PECL termination lines
- Hot pluggable
- Single +5V Power Supply
- Supports Serial ID functionality

PRODUCT OVERVIEW

The MGBC-20-6 GBIC transceiver module is a high performance integrated duplex data link for bi-directional communication over single mode or multimode optical fiber. It is compliant with the Gigabit Interface Converter (GBIC) specification. The MGBC-20 is specifically designed for high speed Fibre Channel data links at 1.0625 Gbps. The Methode GBIC transceiver is hot pluggable which allows a suitably designed enclosure to be changed from one type of external interface to another simply by plugging in a GBIC having the alternative external interface.

SHORT WAVELENGTH LASER

The use of short wavelength lasers and high volume production processes has resulted in a low cost, high performance datalink which communicates reliably at distances of 500 m over 50µm multimode optical fiber with data transfer rates of 1.0625 GBaud.

LONG WAVELENGTH LASER

For intermediate and long reach data links, the MGBC-20-6 with single mode optics can extend the interconnect distance in excess of 20km.

ORDERING INFORMATION

MGBC - 20 - 6 - X - X

SERIAL IDENTIFICATION OPTION

- Blank - No Serial ID
- S - Serial ID

WAVELENGTH

- 1 - 850nm (multimode)
- 2 - 1300nm (single mode) 5km
- 2M - 1300nm (single mode) 10km
- 2L - 1300nm (single mode) 20km

COMMUNICATIONS PROTOCOL

- 6 - Fibre Channel 1.0625 GBaud
- 4 - Gigabit Ethernet 1.25 GBaud



Optoelectronic Products

7444 W. Wilson Ave • Chicago • IL 60656

708/867-9600 • 800/323-6858 • Fax: 708/867-0996

email: optoinfo@methode.com

<http://www.methode.com>

MODULE SPECIFICATIONS - ABSOLUTE MAXIMUM RATINGS

PARAMETER	SYMBOL	MIN	MAX	UNITS	NOTES
Storage Temperature	Tstg	-40	85	°C	
Supply Voltage	VDDT, VDDR		6.00	V	VDD - ground
Data AC Voltage	Tx+, Tx-		2.6	Vpp	Differential
Data DC Voltage	Tx+, Tx-	-10	10	Vpk	V (Tx+ or Tx-) - ground

MODULE SPECIFICATION - RECOMMENDED OPERATING CONDITIONS

PARAMETER	SYMBOL	MIN	TYP	MAX	UNITS	NOTES
Ambient Operating Temperature	Ta	0		70	°C	
Supply Voltage	VDDT, VDDR	4.75	5.00	5.25	VDC	
Baud Rate	BRate		1062.5		MBaud	

MGBC-20-6-X-X Optical Fibre Channel Gigabit Interface Converters (GBIC)



PERFORMANCE SPECIFICATIONS - ELECTRICAL

Ta = 25° C, Vcc = 5.0 V

PARAMETER	SYMBOL	MIN	TYP	MAX	UNITS	NOTES
Bit Error Rate	BER			1E-12		Errors/Bit @ Pr min
Supply Current	Icc		180	250	mA	Ta = 25°C, Vcc = 5.0 V
	Icc			300	mA	0° C < Ta < 70°C, 4.5 V < Vcc < 5.5V
Surge Current	I _{surge}			+30	mA	Surge above steady state value
TRANSMITTER						
PECL Input (Differential)		350	720	2000	mVpp	AC coupled inputs
Input Impedance (Differential)	Z _{in}	135	150	165	ohms	R _{in} > 100 kohms @ DC
Tx_DISABLE Input Voltage - High	ViH	2		V _{DDT} +0.3	V	
Tx_DISABLE Input Voltage - Low	ViL	0		0.8	V	
Tx_FAULT output voltage -- high	VtoH	Vcc-0.5		Vcc+0.3	V	I _o = 400µA; Note 2
Tx_FAULT output voltage -- low	VtoL	0		0.5	V	I _o = -4.0mA
RECEIVER						
PECL Output (Differential)		400	750	1600	mVpp	AC coupled outputs
Output Impedance (Differential)	Z _{out}	135	150	165	ohms	
Rx_LOS Output Voltage - High	VroH	Vcc-0.5		Vcc+0.3	V	I _o = 400µA; Note 2
Rx_LOS Output Voltage - Low	VroL	0		0.5	V	I _o = -4.0mA
Total Jitter [Pk - Pk]	TJ			170	ps	See Note 1
Output Rise/Fall time	t _r , t _f	100		350	ps	20% - 80%
MOD_DEF (0:2)	VoH	2.5			V	With Serial ID
	VoL	0		0.5	V	
	NC	100K				ohms

PERFORMANCE SPECIFICATIONS - OPTICAL 850 nm Laser Multimode

Ta = 25° C, Vcc = 5.0 V

PARAMETER	SYMBOL	MIN	TYP	MAX	UNITS	NOTES
FIBER LENGTH						
50 µm Core Diameter MMF		550	1000		m	BER < 1.0E-12 @ 1.0625 GBaud
62.5 µm Core Diameter MMF (note 3)		300 ³	500		m	BER < 1.0E-12 @ 1.0625 GBaud
TRANSMITTER						
Optical Transmit Power	P _{opt}	-10		-4	dBm	average @ 850 nm
Disabled Power level	P _{off}			-35	dBm	TX_DISABLE active
Optical Center	λ	830	850	860	nm	
Spectral Width	Δλ			3	nm	RMS
Extinction Ratio	ER	9	10		dB	P1/P0
Relative Intensity Noise	RIN			-116	dB/Hz	
Total Jitter [pk - pk]	TJ			210	ps	See note 1
Output Rise, Fall Time	t _r , t _f			350	ps	20% - 80%
RECEIVER						
Optical Input	λ	770		860	nm	
Optical Input Power	Pr	-16	-20	0	dBm	BER < 1.0E-12
Optical Return Loss	ORL	12	30		dB	
RX_LOS- Asserted	Pa	-29			dBm	measured on transition - low to high
RX_LOS - Deasserted	Pd			-16	dBm	measured on transition - high to low
RX_LOS - Hysteresis	Pa - Pd		1.5	5.0	dB	

Note1 - Measured with 2⁷-1 pseudorandom bit sequence.

Note2 - Host Vcc

Note3 - 300m minimum distance on 160MHz-Km 62.5/125µm fiber

MGBC-20-6-X-X Optical Fibre Channel Gigabit Interface Converter (GBIC)



MGBC-20-6-2 PERFORMANCE SPECIFICATIONS - OPTICAL 1300 nm Laser Single Mode

Ta=25°C, Vcc=5V

PARAMETER	SYMBOL	MIN	TYP	MAX	UNITS	NOTES
FIBER LENGTH						
9.0 µm Core Diameter SMF		5	10		km	BER < 1.0E-12 @ 1.0625 GBaud
TRANSMITTER						
Optical Center	λ	1270	1310	1355	nm	
Extinction Ratio	ER	9	10		dB	P1/P0
Disabled Power level	Poff			-35	dBm	TX_DISABLE active
RMS Spectral Width	$\Delta\lambda$			4	nm	RMS
Optical Transmit Power	Popt	-12		-3	dBm	average @ 1310 nm
RECEIVER						
Optical Input Power	Pr	-20		-3	dBm	average power for BER < 1.0E-12
RX_LOS - Asserted	Pa	-29			dBm	Measured on transition - low to high
RX_LOS - Deasserted	Pd			-20	dBm	Measured on transition - high to low
RX_LOS - hysteresis	Pa-Pd		1.5	5.0	dB	

MGBC-20-6-2M PERFORMANCE SPECIFICATIONS - OPTICAL 1300 nm Laser Single Mode

Ta=25°C, Vcc=5V

PARAMETER	SYMBOL	MIN	TYP	MAX	UNITS	NOTES
FIBER LENGTH						
9.0 µm Core Diameter SMF		10	20		km	BER < 1.0E-12 @ 1.0625 GBaud
TRANSMITTER						
Optical Center	λ	1285	1310	1335	nm	
Extinction Ratio	ER	9	10		dB	P1/P0
Disabled Power level	Poff			-35	dBm	TX_DISABLE active
RMS Spectral Width	$\Delta\lambda$			3	nm	RMS
Optical Transmit Power	Popt	-9.5		-3	dBm	average @ 1310 nm
RECEIVER						
Optical Input Power	Pr	-20		-3	dBm	average power for BER < 1.0E-12
RX_LOS - Asserted	Pa	-29			dBm	Measured on transition - low to high
RX_LOS - Deasserted	Pd			-20	dBm	Measured on transition - high to low
RX_LOS - Hysteresis	Pa-Pd		1.5	5.0	dB	

MGBC-20-6-2L PERFORMANCE SPECIFICATIONS - OPTICAL 1300 nm Laser Single Mode

Ta=25°C, Vcc=5V

PARAMETER	SYMBOL	MIN	TYP	MAX	UNITS	NOTES
FIBER LENGTH						
9.0 mm Core Diameter SMF		20	25		km	BER < 1.0E-12 @ 1.0625 GBaud
TRANSMITTER						
Optical Center	λ	1300	1310	1320	nm	
Extinction Ratio	ER	9	10		dB	P1/P0
Disabled Power level	Poff			-35	dBm	TX_DISABLE active
RMS Spectral Width	$\Delta\lambda$			2	nm	RMS
Optical Transmit Power	Popt	-7		-3	dBm	average @ 1310 nm
RECEIVER						
Optical Input Power	Pr	-22		-3	dBm	average power for BER < 1.0E-12
RX_LOS - Asserted	Pa	-29			dBm	Measured on transition - low to high
RX_LOS - Deasserted	Pd			-22	dBm	Measured on transition - high to low
RX_LOS - Hysteresis	Pa-Pd		1.5	5.0	dB	

MGBC-20-6-X-X Optical Fibre Channel Gigabit Interface Converters (GBIC)



TERMINATION CIRCUITS

Inputs to the MGBC-20 transmitter are AC coupled and internally terminated through 75 ohms to AC ground. These modules can operate with PECL or ECL logic levels. The input signal must have at least a 325mV peak-to-peak (single ended) signal swing. Output from the receiver section of the module is also AC coupled and is expected to drive into a 75 ohm load. Different termination strategies may be required depending on the particular Serializer/Deserializer chip set used. **The MGBC-20 product family is designed with AC coupled data inputs and outputs to provide the following advantages:**

- Close positioning of SERDES with respect to transceiver; allows for shorter line lengths and at gigabit speeds reduces EMI.
- Minimum number of external components.
- Internal termination reduces the potential for unterminated stubs which would otherwise increase jitter and reduce transmission margin.

Subsequently, this affords the customer the ability to optimally locate the SERDES as close to the MGBC-20 as possible and save valuable real estate. At gigabit rates this can provide a significant advantage resulting in better transmission performance and accordingly better signal integrity.

Figure 1 illustrates the recommended transmit and receive data line terminations.

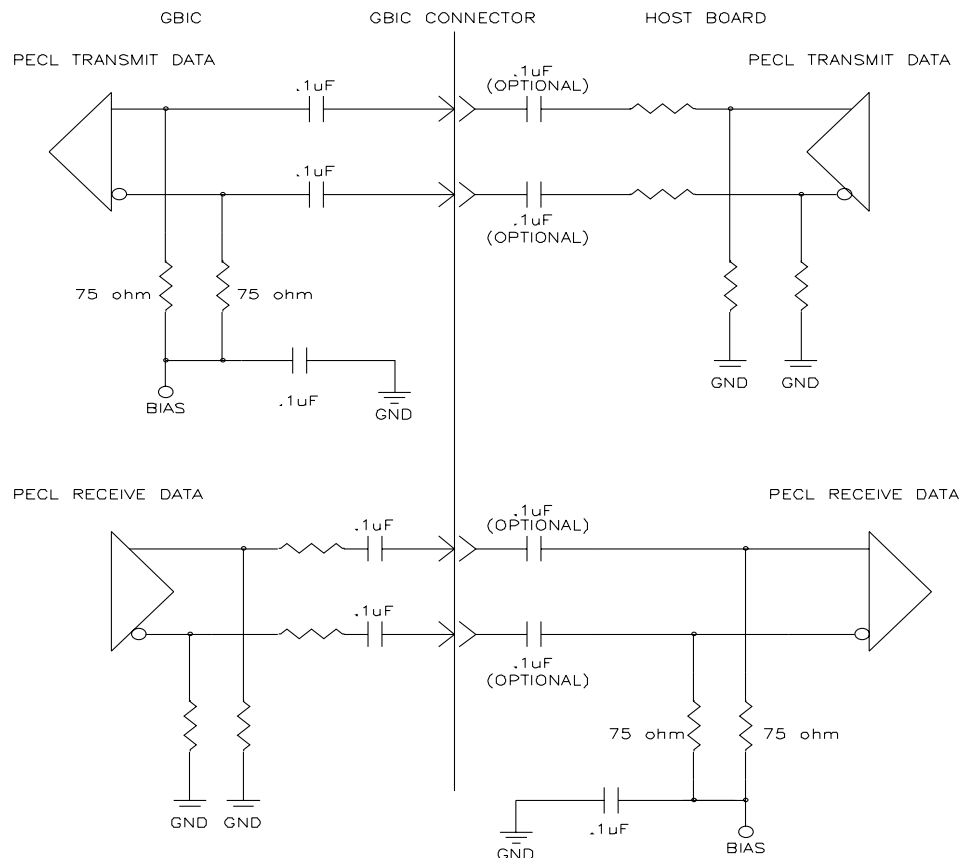

FIGURE 1: Example of termination circuits for Drivers and Receivers in the host and the GBIC

MGBC-20-6-X-X Optical Fibre Channel Gigabit Interface Converter (GBIC)



POWER COUPLING

A suggested layout for power and ground connections is given in figure 2A below. Connections are made via separate voltage and ground planes. The mounting posts are at case ground and should not be connected to circuit ground. The ferrite bead should provide a real impedance of 50 to 100 ohms at 100 to 1000 MHz. Bypass capacitors should be placed as close to the 20 pin connector as possible.

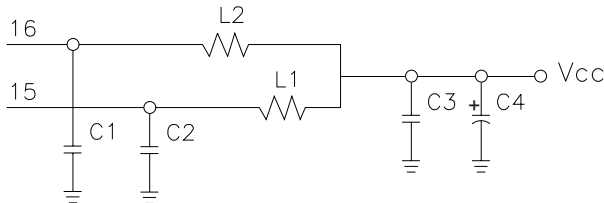

VALUES:

- C1, C2 = 1000pF, COG
- C3, = 0.1uF
- C4, = 10uF, Tantalum
- L1, L2 = Real impedance of 50 to 100 Ohms to 1000 MHz.

Figure 2A. Suggested Power Coupling

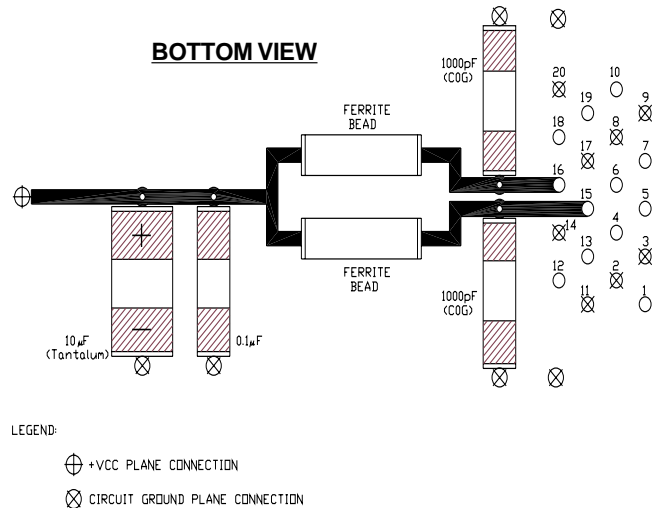

Figure 2B. Suggested Power Coupling

SIGNAL DESCRIPTION:

TX_FAULT: Active high signal. A TX_FAULT is defined as the failure of the optical output of the GBIC and it is internally latched. On the rising edge of the TX_DISABLE, the latched laser fault will be cleared and TX_FAULT will remain deasserted while TX_DISABLE is asserted. The host shall provide a 4.7K to 10K Ohm pull up resistor to Vcc. The TX_FAULT will also be asserted but not latched if the Vcc falls below the lower Vcc limit.

TX_DISABLE : Active high logic input which disables the optical output. This signal is driven by the host. While asserted, the GBIC module disables all laser light output. This pin is internally pulled up to Vcc through a 10K Ohm resistor for short wavelength and a 4.7K Ohm resistor for long wavelength. The TX_DISABLE must be pulled low or connected to circuit ground by the host to enable the GBIC output.

RX_LOS : The RX_LOS signal is intended as a preliminary indication to the system in which the GBIC is installed that the link signals are likely to be outside the required values for proper operation. Such indications typically point to non-installed cables, broken cables, or a disabled, failing or powered off transmitter at the far end of the cable. Additional indications are provided by the system in which the GBIC is installed to verify that the information being transmitted is valid, correctly encoded and in the correct format. Such additional indications are outside the scope of the GBIC specification. RX_LOS will also be asserted if the Vcc falls below the lower Vcc limit. The host shall provide a 4.7k to 10k Ohm pullup resistor to Vcc.

RGND

Receiver ground. It is internally connected to TGND plane.

TGND

Transmitter ground. It is internally connected to RGND plane.

±RX_DAT

High speed serial differential PECL receiver data.

±TX_DAT

High speed serial differential PECL transmit data.

MGBC-20-6-X-X Optical Fibre Channel Gigabit Interface Converters (GBIC)



V_{DDT}

Transmitter +5V power supply

V_{DDR}

Receiver +5V power supply

GBIC MOD_DEF DETERMINATION

The module definition of GBIC that is installed is indicated by the 3 module definition pins. The host shall provide 4.7K Ohm pullup resistor to V_{DDT}. The assigned values for the MOD_DEF(0:2) are shown in table 1. The value NC indicates that the GBIC makes no connection to the pin.

Module Definition	MOD_DEF(0) Pin 4	MOD_DEF(1) Pin 5	MOD_DEF(2) Pin 6	Interpretation by host
0	NC	NC	NC	GBIC not present
1	NC	NC	TTL LOW	Copper Style 1 pr Style 2 connector, 1.0625 Gbd, 100-TW-EL-S or 100-TP-EL-S, active inter-enclosure connection and IEEE802.3 1000BASE-CX
2	NC	TTL LOW	NC	Copper Style 1 pr Style 2 connector, 1.0625 Gbd, 100-TW-EL-S or 100-TP-EL-S, active or passive inter-enclosure connection and IEEE802.3 1000BASE-CX
3	NC	TTL LOW	TTL LOW	Optical LW, 1.0625 GBD 100-SM-LC-L
4	TTL LOW	SCL	SDA	Serial module definition protocol
5	TTL LOW	NC	TTL LOW	Optical SW, 1.0625 Gbd 100-M5-SN-I or 100-M6-SN-I
6	TTL LOW	TTL LOW	NC	Optical LW, 1.0625 Gbd, 100-Sm-LC-L and similar to 1.25 Gbd IEEE 802.3z 1000BASE-LX, single mode.
7	TTL LOW	TTL LOW	TTL LOW	Optical SW, 1.0625 Gbd, 100-M5-SN-1 or 100-M6-SN-I and 1.25 Gbd, IEEE 802.3z 1000BASE-SX

Table 1: MOD_DEF(0:2)

GBIC TIMING PARAMETERS

The Timing parameters For GBIC management are shown in table 2.

PARAMETER	SYMBOL	MIN.	MAX.	UNIT	CONDITIONS
TX_DISABLE assert time	t _{off}		10	µsec	Rising edge of TX_DISABLE to fall of output signal below 10% of nominal
TX_DISABLE negate time	t _{on}		1	msec	Falling edge of TX_DISABLE to rise of output signal above 90% of nominal
Time to initialize includes reset of TX_FAULT	t _{init}		300	msec	From power on or hot plug after V _{DDT} > 4.75 volts or from negation of TX_DISABLE during reset of TX_FAULT
TX_FAULT from fault to assertion	t _{fault}		100	µsec	From occurrence of fault (output safety violation or V _{DDT} < 4.5 volts)
TX_DISABLE time to start reset	t _{reset}	10		µsec	TX_DISABLE HIGH before TX_DISABLE set LOW
RX_LOS assert delay	t _{loss_on}		100	µsec	From detection of loss of signal to assertion of RX_LOS
RX_LOS negate delay	t _{loss_off}		100	µsec	From detection of presence of signal to negation of RX_LOS

Table 2: Timing parameters for GBIC management

MGBC-20-6-X-X Optical Fibre Channel Gigabit Interface Converter (GBIC)

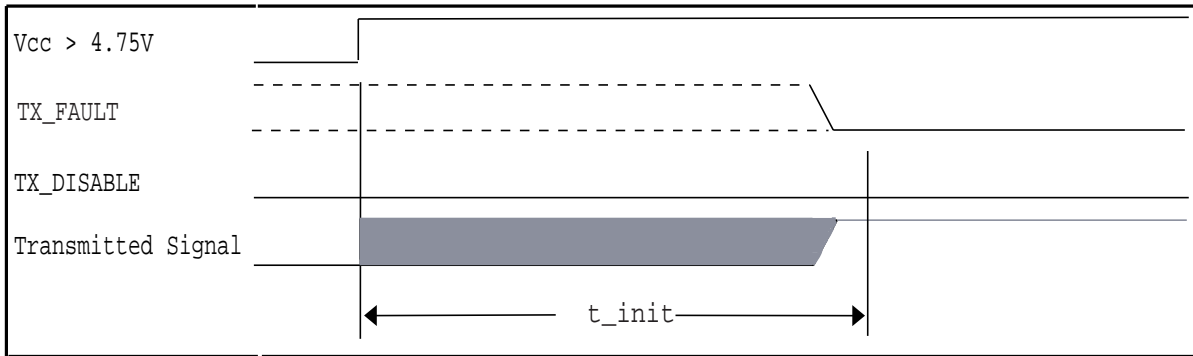

Figure 3: Power on initialization of GBIC with TX_DISABLE negated

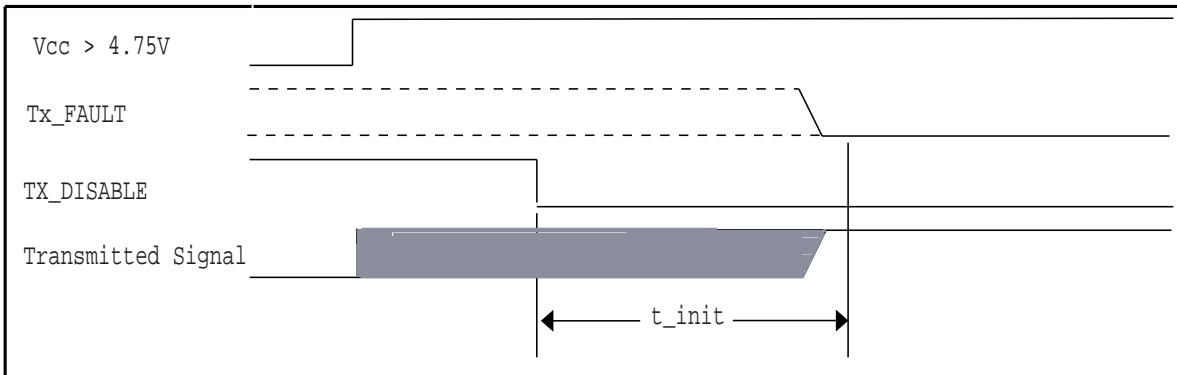

Figure 4: Power on initialization of GBIC with TX_DISABLE asserted

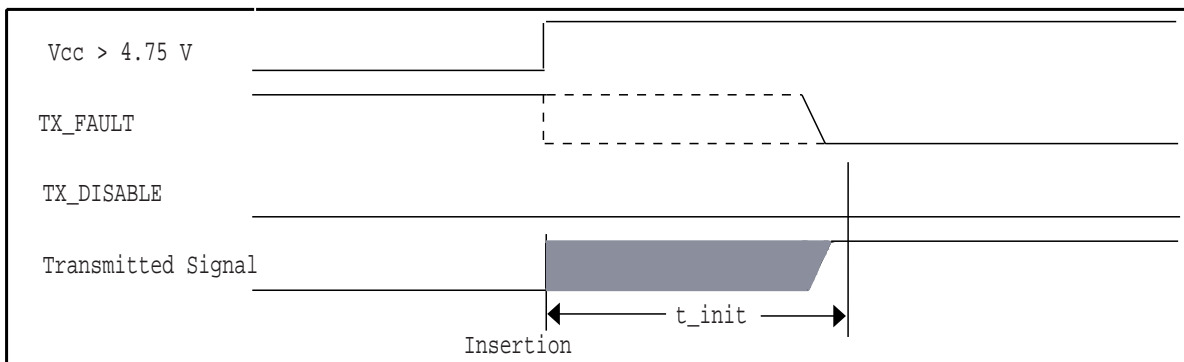

Figure 5: Example of initialization during hot plugging with TX_DISABLE negated.

MGBC-20-6-X-X Optical Fibre Channel Gigabit Interface Converters (GBIC)

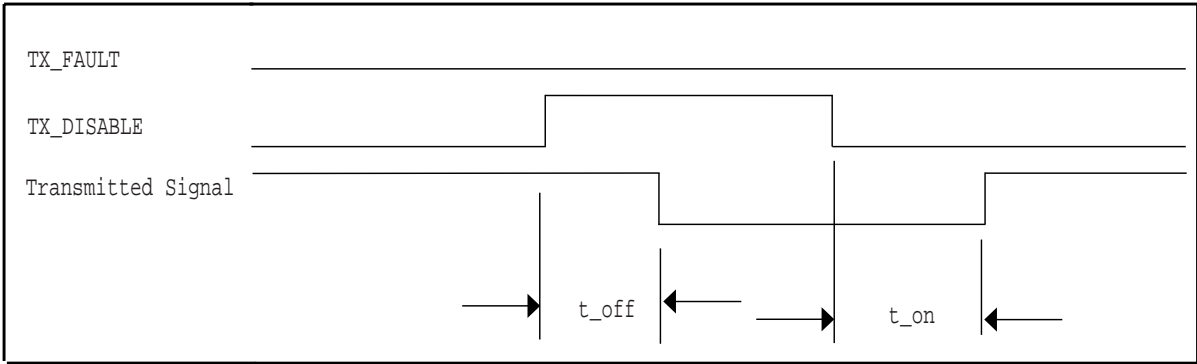

Figure 6: Management of GBIC during normal operation with TX_DISABLE implemented.

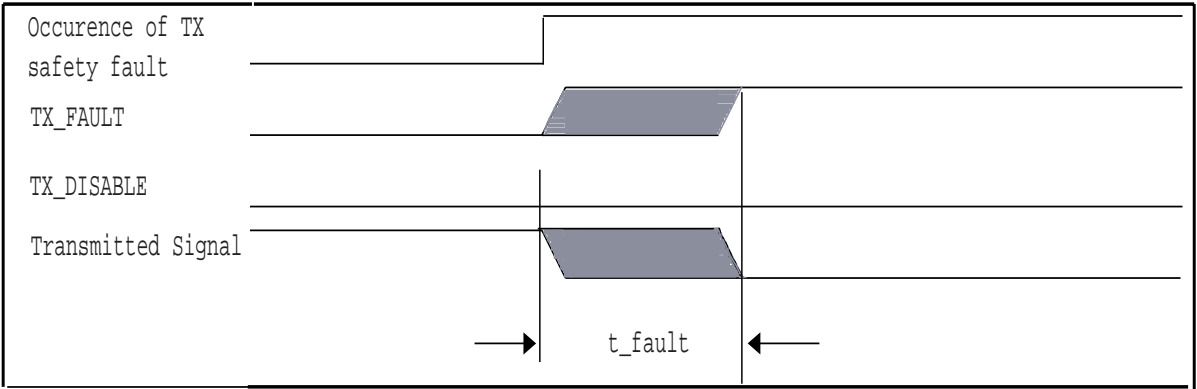

Figure 7: Detection of transmitter safety fault condition

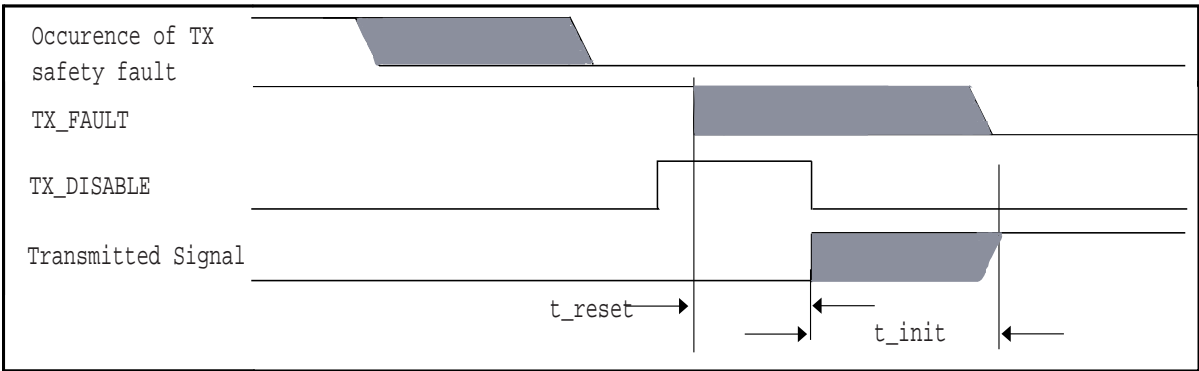

Figure 8: Successful recovery from transient safety fault condition

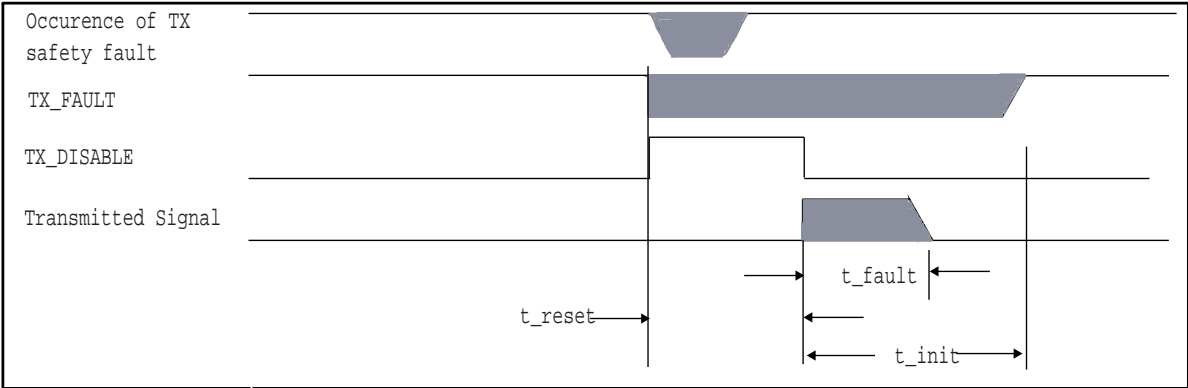

Figure 9: Unsuccessful recovery from safety fault condition

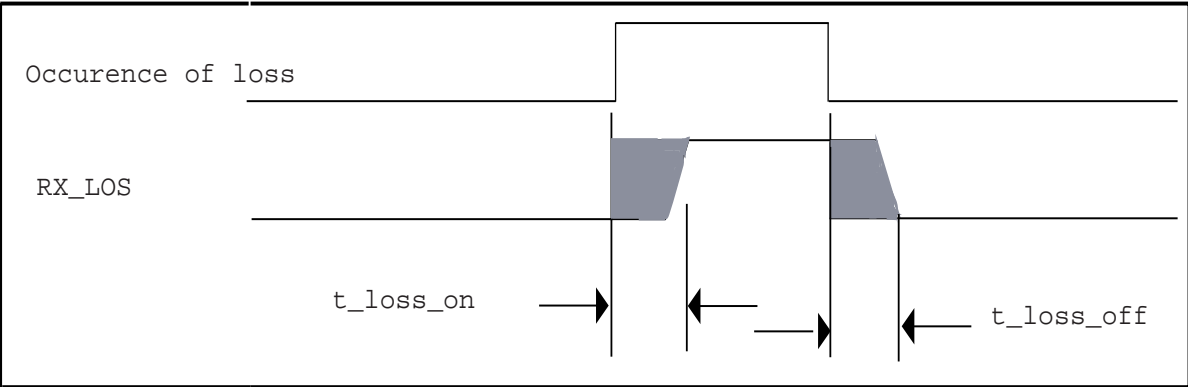

Figure 10: Timing of RX_LOS detection

MGBC-20-6-X-X Optical Fibre Channel Gigabit Interface Converters (GBIC)



SERIAL IDENTIFICATION:

A GBIC having module definition 4 provides access to sophisticated identification information that describes the GBIC's capabilities, standard interfaces, manufacturer and other information. The serial interface uses the 2-wire serial CMOS E2PROM protocol defined for the ATMEL AT24C01A/02/04 family of components. The memories are organized as a series of 8-bit data words that can be addressed individually or sequentially.

Data Address	Field Size (Bytes)	Name of field	Description of field
BASE OF FIELDS			
0	1	Identifier	Type of serial transceiver(see table D.2)
1	1	Reserved	
2	1	Connector	Code for connector type(see table D.3)
3-10	8	Transceiver	Code for electronic compatibility or optical compatibility (see table D.5)
11	1	Encoding	Code for serial encoding algorithm(see table D.4)
12	1	BR, Nominal	Nominal bit rate, units of 100Mbps
13-14	2	Reserved	
15	1	Length (9 μ)	Link Length supported for 9/125 μ m fiber, units of 100 m
16	1	Length (50 μ)	Link Length supported for 50/125 μ m fiber, units of 10 m
17	1	Length (62.5 μ)	Link Length supported for 62.5/125 μ m fiber, units of 10 m
18	1	Length (Copper)	Link Length supported for copper, units of meters
19	1	Reserved	
20-35	16	Vendor name	GBIC vendor name (ASCII)
36	1	Reserved	
37-39	3	Vendor OUI	GBIC vendor IEEE company ID
40-55	16	Vendor PN	Part number provided by GBIC vendor (ASCII)
56-59	4	Vendor rev.	Revision level for part number provided by vendor (ASCII)
60-62	3	Reserved	
63	1	CC_BASE	Check code for Base ID fields (address 0 to 62)
EXTENDED ID FIELDS			
64-65	2	Options	Indicates which optional GBIC signals are implemented(see table D.6)
66	1	BR, Max	Upper bit rate margin, units of %
67	1	BR, Min	Lower bit rate margin, units of %
68-83	16	Vendor SN	Serial number provided by vendor (ASCII)
84-91	8	Date Code	Vendor's manufacturing date code(see table D.7)
92-94	3	Reserved	
95	1	CC_EXT	Check code for the Extended ID fields (address 64 to 94)
VENDOR SPECIFIC ID FIELDS			
96-127	32	Read-only	Vendor specific data, read only
128-511	384	Reserved	
512-n			Vendor specific

Table D.1: Serial ID: Data Fields

MGBC-20-6-X-X Optical Fibre Channel Gigabit Interface Converter (GBIC)



IDENTIFIER

The identifier value specifies the physical device described by the serial information. This value shall be included in the serial data. The defined identifier values are shown in table D.2.

Value	Description of physical device
00h	Unknown or unspecified
01h	GBIC
02h	Module/connector soldered to motherboard
03-7Fh	Reserved
80-FFh	Vendor specific

Table D.2: Identifier Values

CONNECTOR

The connector value indicates the external connector provided on the interface. This value shall be included in the serial data. The defined connector values are shown in table D.3.

Value	Description of connector
00h	Unknown or unspecified
01h	Fibre Channel definition of SC connector
02h	Fibre Channel Definition of style 1 copper connector
03h	Fibre Channel definition of style 2 copper connector
04h	Fibre Channel definition of BNC/TNC
05h	Fibre channel definition of coaxial headers
06-7Fh	Reserved
80-FFh	Vendor Specific

Table D.3: Connector Values

ENCODING

The encoding value indicates the serial encoding mechanism that is the nominal design target of the particular GBIC. The value shall be contained in the serial data. The defined encoding values are shown in table D.4

Value	Description of encoding mechanism
00h	Unspecified
01h	8B10B
02h	7B5B
03h	NRZ
04h	Manchester
05h-FFh	Reserved

Table D.4: Encoding Codes

MGBC-20-6-X-X Optical Fibre Channel Gigabit Interface Converters (GBIC)



TRANSCEIVER

The following bit significant indicators define the electronic or optical interfaces that are supported by the GBIC. At least one bit shall be set in this field. For the Fibre Channel GBICs, the Fibre Channel speed, transmission media, transmitter technology, and the distance capability shall all be indicated. The defined transceiver codes are shown in table D.5

Data Addr	Bit (note a)	Description of transceiver	Data Addr	Bit (note a)	Description of transceiver
Reserved Standard Compliance Codes			Fibre Channel link length		
3	7-0	Reserved	7	7	Reserved
4	7-0	Reserved	7	6	Short distance (S)
SONET Compliance Codes			7	5	Intermediate distance (I)
5	7	Reserved	7	4	Long distance (L)
5	6	OC 12, single mode long reach	Fibre Channel transmitter technology		
5	5	OC 12, single mode intermediate reach	7	3-2	Reserved
5	4	OC 12, multi-mode short reach	7	1	Longwave laser (LC)
5	3	Reserved	7	0	Electrical inter-enclosure (EL)
5	2	OC 3, single mode long reach	8	7	Electrical inter-enclosure (EL)
5	1	OC 3, single mode intermediate reach	8	6	Shortwave laser w/o OFC (SN)
5	0	OC 3, multi-mode short reach	8	5	Shortwave laser w/ OFC (SL)
Gigabit Ethernet Compliance Codes			8	4	Longwave laser (LL)
6	7-4	Reserved	Fibre Channel transmission media		
6	3	1000BASE-T	8	0-3	Reserved
6	2	1000BASE-CX	9	7	Twin axial pair (TW)
6	1	1000BASE-LX	9	6	Shielded twisted pair (TP)
6	0	1000BASE-SX	9	5	Miniature coax (MI)
			9	4	Video coax (TV)
			9	3	Multi-mode, 62.5µ (M6)
			9	2	Multi-mode, 50µ (M5)
			9	1	Reserved
			9	0	Single mode (SM)
			Fibre Channel speed		
			10	7-5	Reserved
			10	4	400 MBps
			10	3	Reserved
			10	2	200 Mbps
			10	1	Reserved
			10	0	100 Mbps

Table D.5: Transceiver Codes

MGBC-20-6-X-X Optical Fibre Channel Gigabit Interface Converter (GBIC)



BR, nominal

The nominal bit rate (BR, nominal) is specified in units of 100 Megabits per second, rounded off to the nearest 100 Megabits per second. The bit rate includes those bits necessary to encode and delimit the signal as well as those bits carrying data information. A value of 0 indicates that the bit rate is not specified and must be determined from the transceiver technology. The actual information transfer rate will depend on the encoding of the data, as defined by the encoding value.

Length (9µm)

This value specifies the link length that is supported by the GBIC while operating in compliance with the applicable standards using single mode fiber. The value is in units of 100 meters. A value of 255 means that the GBIC supports a link length greater than 25.4 km. A value of zero means that the GBIC does not support single mode fiber or that the length information must be determined from the transceiver technology.

Length (50µm)

This value specifies the link length that is supported by the GBIC while operating in compliance with the applicable standards using 50 micron multimode fiber. The value is in units of 10 meters. A value of 255 means that the GBIC supports a link length greater than 2.54 km. A value of zero means that the GBIC does not support 50 micron multimode fiber or that the length information must be determined from the transceiver technology.

Length (62.5µm)

The value specifies the link length that is supported by the GBIC while operation in compliance with the applicable standards using 62.5 micron multi-mode fiber. The value is in units of 10 meters. A value of 255 means that the GBIC supports a link length greater than 2.54km. A value of zero means that the GBIC does not support 62.5 micron multi-mode fiber or that the length information must be determined from the transceiver technology. It is common for GBICs to support both 50 micron and 62.5 micron fiber.

Length (Copper)

The value will always be zero which means that the GBIC does not support copper cables.

Vendor name

The vendor name is a 16 character field that contains ASCII characters, left-aligned and padded on the right with ASCII spaces (20h). The vendor name shall be the full name of the corporation, a commonly accepted abbreviation of the name of the corporation, the SCSI company code for the corporation, or the stock exchange code for the corporation. At least one of the vendor name or the vendor OUI fields shall contain valid serial data.

Vendor OUI

The vendor organizationally unique identifier field (vendor OUI) is a 3-byte field that contains the IEEE Company Identifier for the vendor. A value of zero in the 3-byte field indicates that the Vendor OUI is unspecified.

Vendor PN

The vendor part number (vendor PN) is a 16-byte field that contains ASCII characters, left-aligned and padded on the right with ASCII spaces (20h), defining the vendor part number or product name. A value of all zero in the 16-byte field indicates that the vendor PN is unspecified.

Vendor Rev

The vendor revision number (vendor rev) is a 4-byte field that contains ASCII characters, left-aligned and padded on the right with ASCII spaces (20h), defining the vendor's product revision number. A value of all zero in the 4-byte field indicates that the vendor PN is unspecified.

CC_BASE

The check code is a one byte code that can be used to verify that the first 64 bytes of serial information in the GBIC is valid. The check code shall be the low order 8 bits of the sum of the contents of all the bytes from byte 0 to 62, inclusive

MGBC-20-6-X-X Optical Fibre Channel Gigabit Interface Converters (GBIC)



OPTIONS

The bits in the option field shall specify the options implemented in the GBIC as described in table D.6.

Data address	bit	Description of option
64	7-0	Reserved
65	7-5	Reserved
65	4	TX_DISABLE is implemented and disables the serial output.
65	3	TX_FAULT signal implemented.
65	2	Loss of signal implemented, signal inverted from definition 3.3. NOTE: This is not standard GBIC behavior and should be avoided, since non-interoperable behavior results.
65	1	Loss of signal implemented
65	0	Reserved

Table D.6: Option values

BR, max

The upper bit rate limit at which the GBIC will still meet its specifications (BR, max) is specified in units of 1% above the nominal bit rate. A value of zero indicates that this field is not specified.

BR, min

The lower bit rate limit at which the GBIC will still meet its specifications (BR, min) is specified in units of 1% below the nominal bit rate. A value of zero indicates that this field is not specified.

Vendor SN

The vendor serial number (vendor SN) is a 16 character field that contains ASCII characters, left-aligned and padded on the right with ASCII spaces (20h), defining the vendor's serial number for the GBIC. A value of all zero in the 16-byte field indicates that the vendor PN is unspecified.

Date Code

The date code is an 8-byte field that contains the vendor's date code in ASCII characters. The date code is mandatory. The date code shall be in format specified by table D.7.

Data Address	Description of field
84-85	ASCII code, two low order digits of year. (00 = 2000).
86-87	ASCII code, digits of month (01 = Jan through 12 = Dec)
88-89	ASCII code, day of month (01-31)
90-91	ASCII code, vendor specific lot code, may be blank

Table D.7: Date Code

MGBC-20-6-X-X Optical Fibre Channel Gigabit Interface Converter (GBIC)



MECHANICAL DIMENSIONS (inches)

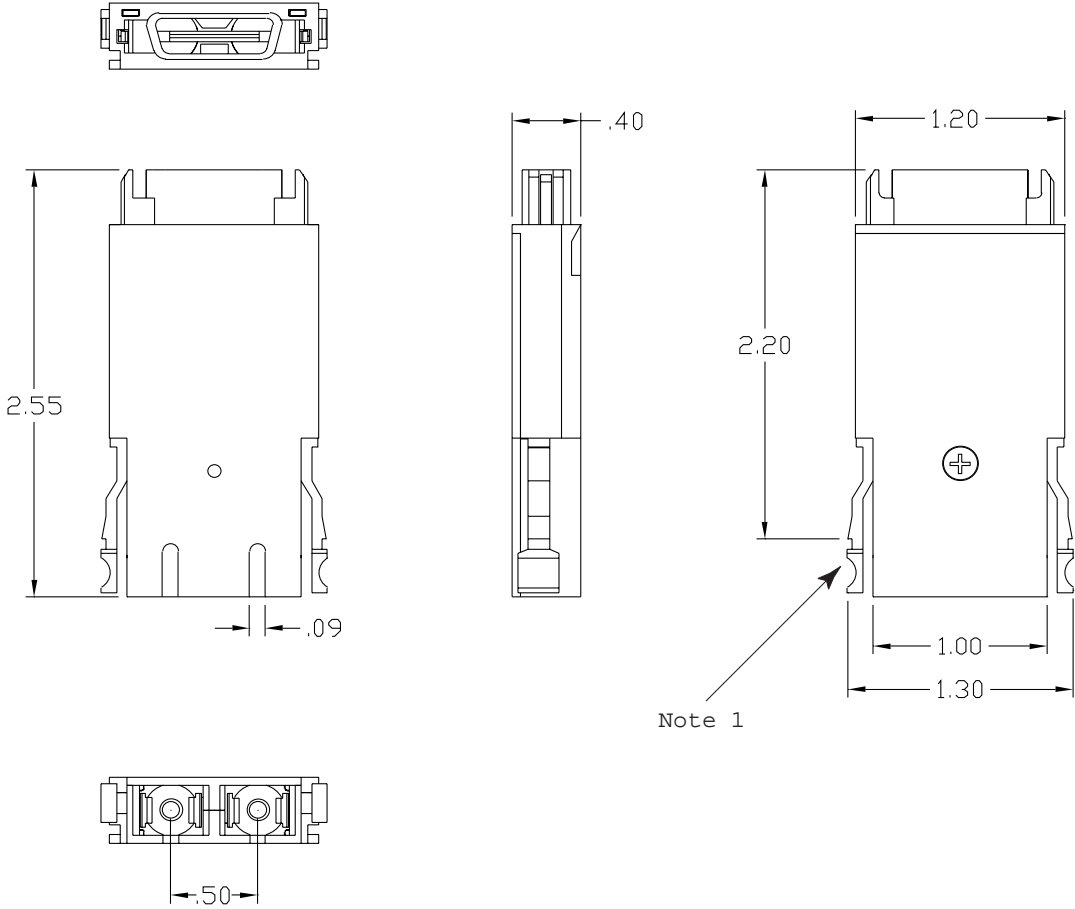

Note 1. All GBIC latches are color coded blue for single mode and beige or black for multimode operation.

MGBC-20-6-X-X Optical Fibre Channel Gigabit Interface Converters (GBIC)



ELECTRICAL INTERFACE, PIN DESCRIPTIONS

PIN 1	RX_LOS	The RX_LOS signal is intended as a preliminary indication to the system in which the GBIC is installed that the link signals are likely to be outside the required values for proper operation. The host shall provide a 4.7K to 10K ohm pullup resistor to $V_{DD,R}$
PIN 2	RGND	Receiver Ground
PIN 3	RGND	Receiver Ground
PIN 4	MOD_DEF (0)	GBIC module definition and presence, bit 0, 4.7K to 10K Ohm pullup resistor to $V_{DD,T}$ on host.
PIN 5	MOD_DEF (1)	GBIC module definition and presence, bit 1 4.7K to 10K Ohm pullup resistor to $V_{DD,T}$ on host.
PIN 6	MOD_DEF (2)	GBIC module definition and presence, bit 2, 4.7K to 10K Ohm pullup resistor to $V_{DD,T}$ on host.
PIN 7	TX_DISABLE	Active high logic input which disables the optical output . This signal is driven by the host. This pin is internally pulled up to $V_{DD,T}$ through a 10K ohm resistor for short wavelength and a 4.7K ohm resistor for long wavelength.
PIN 8	TGND	Transmitter Ground
PIN 9	TGND	Transmitter Ground
PIN 10	TX_FAULT	Active high signal. A TX_FAULT is defined as the failure of the optical output of the GBIC and it is internally latched. The host shall provide a 4.7K to 10K ohm pullup resistor to $V_{DD,T}$
PIN 11	RGND	Receiver Ground
PIN 12	-RX_DAT	Receiver Data inverted differential output.
PIN 13	+RX_DAT	Receiver Data Non-inverted differential output.
PIN 14	RGND	Receiver Ground
PIN 15	$V_{DD,R}$	+5V supply for Receiver section.
PIN 16	$V_{DD,T}$	+5V supply for Transmitter section.
PIN 17	TGND	Transmitter Ground
PIN 18	+TX_DAT	Transmitter Data Non-inverted differential output.
PIN 19	-TX_DAT	Transmitter Data inverted differential output.
PIN 20	TGND	Transmitter Ground



Optoelectronic Products

7444 West Wilson Avenue • Chicago, IL 60656
708/867-9600 • 800/323-6858 • Fax: 708/867-0996
email:optoinfo@methode.com
http://www.methode.com

IMPORTANT NOTICE

Methode Electronics reserves the right to make changes to or discontinue any optical link product or service identified in this publication, without notice, in order to improve design and/or performance. Methode advises its customers to obtain the latest version of the publications to verify, before placing orders, that the information being relied on is current. Methode Electronics GBIC products are covered under U.S. Patent Numbers 5,546,281, 5,717,533, 5,734,558, and 5,812,582.

Methode Electronics warrants performance of its optical link products to current specifications in accordance with Methode Electronics standard warranty. Testing and other quality control techniques are utilized to the extent that Methode Electronics has determined it to be necessary to support this warranty. Specific testing of all parameters of each optical link product is not necessarily performed on all optical link products.

Methode Electronic products are not designed for use in life support appliances, devices, or systems where malfunction of a Methode Electronics product can reasonably be expected to result in a personal injury. Methode Electronics customers using or selling optical link products for use in such applications do so at their own risk and agree to fully indemnify Methode Electronics for any damages resulting from such improper use or sale.

Methode Electronic assumes no liability for Methode Electronics applications assistance, customer product design, software performance, or infringement of patents or services described herein. Nor does Methode Electronics warrant or represent that a license, either expressed or implied is granted under any patent right, copyright, or intellectual property right, and makes no representations or warranties that these products are free from patent, copyright, or intellectual property rights.

Applications that are described herein for any of the optical link products are for illustrative purposes only. Methode Electronics makes no representation or warranty that such applications will be suitable for the specified use without further testing or modification.