

# DWDM SFP Optical Transceiver—C-Band for up to 180 km Reach SFP Series



## Key Features

- Support line rate from 100 Mbps to 3.1 G
- Compliant with DWDM SFP MSA Revision 1.0
- Up to 180 km reach, DWDM with 100 GHz ITU Grid, C-band applications
- Operating temperature range of  $-5$  to  $70^{\circ}\text{C}$  or  $-40$  to  $85^{\circ}\text{C}$
- Maximum power dissipation of 1.3 W for  $-5$  to  $70^{\circ}\text{C}$  temperature range, or 1.5 W for  $-40$  to  $85^{\circ}\text{C}$  temperature range
- Compliant with RoHS 6/6
- Single 3.3 V power supply
- Enhanced digital diagnostic monitoring support
- Internal AC-coupled electrical interface

## Applications

- Dense WDM
- SONET OC-3/12/48
- SDH STM-1/4/16
- Fast Ethernet and Gigabit Ethernet
- Fibre Channel

## Compliance

- SFF 8472 Revision 10.3
- DWDM SFP MSA
- ITU-T G.957
- IEEE 802.3-2005
- Class 1 Laser Safety
- Compliance with Telcordia GR-468

The JDSU RoHS-compliant small form factor pluggable (SFP) optical transceiver is an integrated fiber optic transceiver that provides a high-speed serial link at signaling rates from 100 Mbps to 3.1 G. The module complies with the dense wavelength-division multiplexing (DWDM) SFP MSA.

The DWDM SFP optical transceiver complies with ITU-T G.957 with 100 GHz ITU grid channel spacing for up to 180 km reach (SONET OC-48/SDH STM-16); and IEEE 802.3-2005 DWDM for 180 km reach (Gigabit Ethernet and 1 G Fibre Channel) standards. The JDSU DWDM SFP optical transceiver is compatible with Fast Ethernet, SONET OC-3 and OC-12, and SDH STM-1 and STM-4 standards.

Our DWDM SFP optical transceiver integrates the receive and transmit path on one module. On the transmit side, the serial data stream is passed to a laser driver. The laser drivers biases and modulates a cooled directly modulated laser (DML), enabling data transmission over single-mode fiber through an industry-standard LC connector. On the receive side, the optical data stream is recovered from an avalanche photodiode (APD) photodetector, transimpedance amplifier, and passed to a post amplifier. This module also features a hot-pluggable, SFI-compliant electrical interface.

## Section 1 Functional Description

The RoHS-compliant SFP optical transceiver is a fully duplexed serial electric, serial optical device with both transmit and receive functions contained in a single module that provides a high-speed serial link at signaling rates from 100 Mbps to 3.1 G. It is compliant with Telcordia GR-253-CORE and ITU-T G.957 with 100 GHz ITU grid channel spacing for 180 km reach (SONET OC-48 / SDH STM-16); and IEEE 802.3-2005 DWDM for 180 km reach (Gigabit Ethernet and 1 G Fibre Channel) applications. The DWDM SFP optical transceiver is compatible with Fast Ethernet, SONET OC-3 and OC-12, and SDH STM-1 and STM-4 applications. The transceiver is also fully compliant with the SFP module MSA INF8074i Rev. 1.0. A block diagram of the DWDM SFP optical transceiver is shown in Figure 1.

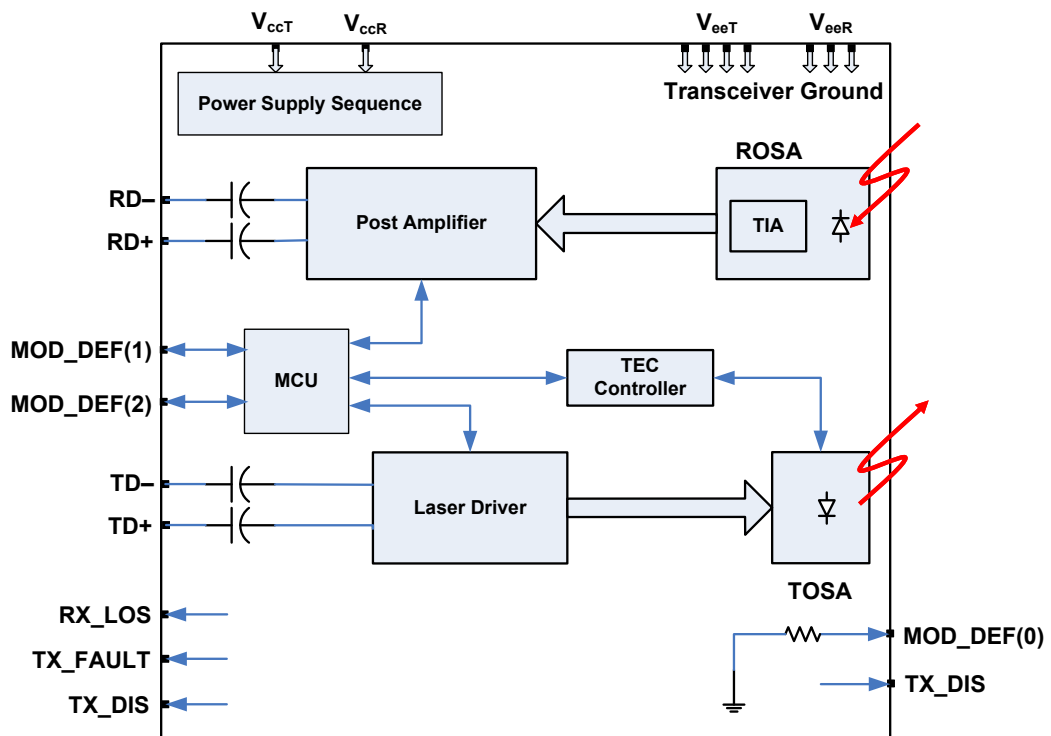

Figure 1. DWDM SFP optical transceiver functional block diagram

The DWDM SFP optical transceiver does not require rate selection to operate at the designated line rate. It has several low-speed interface connections, including a two-wire serial interface. These connections also include transceiver presence (Mod\_Def(0)), transmitter fault (TX\_FAULT), transmitter disable (TX\_DIS), and receive loss (RX\_LOS).

## Transmitter

The transmitter path converts serial NRZ electrical data from line rate of 100 Mbps to 3.1 G to a standard, compliant optical signal. The transmitter accepts a 100  $\Omega$  differential 400 mV peak-to-peak to 2400 mV peak-to-peak CML electrical signal on TD– and TD+ pins.

Inside the module, the differential signals pass through a laser driver, which transforms the small swing digital voltage to an output modulation that drives a cooled DML laser. The optical signal is engineered to meet SONET/SDH, Ethernet, and Fibre Channel rate DWDM specifications at ITU grids with 100 GHz channel spacing. Closed-loop control of the transmitted laser power, modulation swing, and center wavelength over temperature and voltage variations is provided. The laser is coupled to single-mode optical fiber through an industry-standard LC optical connector.

## Receiver

The receiver converts incoming DC-balanced serial NRZ optical data from 100 Mbps to 3.1 G line rates into serial electrical data. Light is coupled to an APD photodetector from single-mode optical fiber through an industry-standard LC optical connector. The electrical current from the APD photodetector converts to voltage in a high-gain transimpedance amplifier.

The amplified signal is passed to a post amplifier. Loss of signal and signal lock detection is included in the receive circuitry that is reflected in the RX\_LOS status pin. The recovered data is output on the RD+ and RD– pins as a 100  $\Omega$  differential 400 mV to 800 mV peak-to-peak CML signal. The output signal meets SFP MSA requirements.

## Low-Speed Signaling

Low-speed signaling is based on low voltage TTL (LVTTTL) operating at a nominal voltage of 3.3 V.

MOD\_DEF(1)/MOD\_DEF(2): Two-wire serial interface clock and data line — Hosts should use a pull-up resistor connected to  $V_{CC}$  3.3 V on the two-wire interface MOD\_DEF(1) (clock), MOD\_DEF(2) (data), and all low-speed outputs.

TX\_FAULT: Output pin — When high, indicates possible transmitter operational fault or a status critical to the host system.

TX\_DIS: Input pin — When asserted high, the transmitter output is turned off.

Mod\_DEF(0): Output pin — When pulled to ground by the module, it indicates that the module is present.

RX\_LOS: Output pin — Asserted high when insufficient optical power for reliable signal reception is received.

## Section 2 Application Schematics

Power supply filtering is recommended for the DWDM SFP optical transceiver. To limit wideband noise power, the host system and module must each meet a maximum of two-percent peak-to-peak noise when measured with a 1 MHz low-pass filter. In addition, the host system and the module must each meet a maximum of three-percent peak-to-peak noise when measured with a filter from 1 to 10 MHz. Figure 2 shows recommended power-supply network connections to the DWDM SFP optical transceiver.

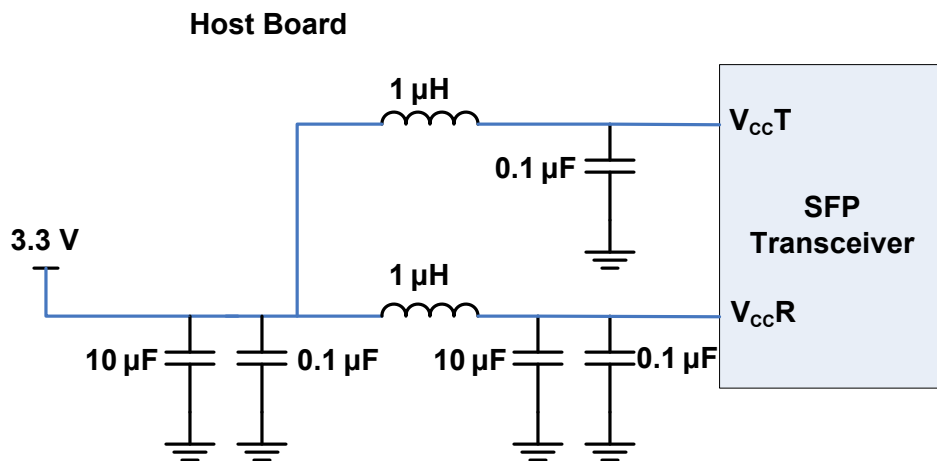

Notes:

1. Place power-supply filtering components as close as possible to the V<sub>cc</sub> pins of the host connector for optimal performance.
2. ESR of the inductor should be less than 0.5 Ω to ensure proper power supply levels.

**Figure 2. Application schematics for the DWDM SFP optical transceiver**

## Section 3 Specifications

Technical specifications related to the DWDM SFP optical transceiver includes:

Section 3.1	Pin Function Definitions
Section 3.2	Absolute Maximum Ratings
Section 3.3	Electrical Characteristics
Section 3.4	Jitter Specifications
Section 3.5	Timing Requirement of Control and Status I/O
Section 3.6	SFP Two-Wire Interface Protocol and Management Interface
Section 3.7	Optical Transmitter Characteristics
Section 3.8	Optical Receiver Characteristics
Section 3.9	Wavelength Availability
Section 3.10	Regulatory Compliance
Section 3.11	Module Outline
Section 3.12	Connectors

### 3.1 Pin Function Definitions

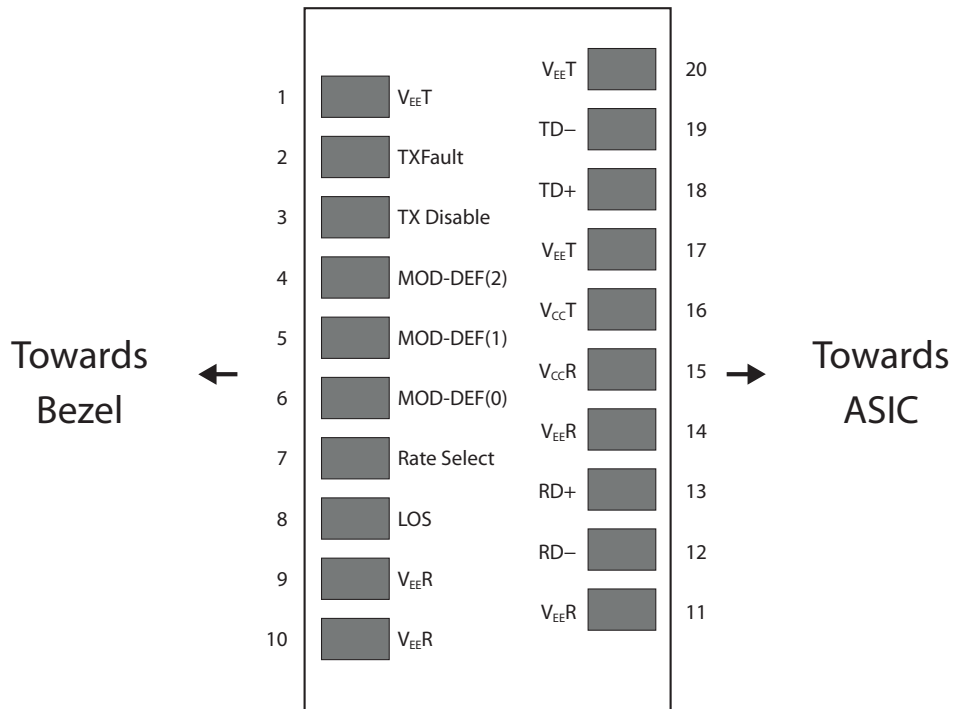

Figure 3. SFP optical transceiver pin-out on host board

## 6

**Table 1. SFP Optical Transceiver Pin Descriptions**

Pin Number	Type	Name	Description
1	V <sub>EE</sub> T	GND <sup>1</sup>	Transmit ground
2	TX_FAULT <sup>2</sup>	LVTTL-O	Transmitter fault indicator
3	TX_DIS	LVTTL-I	Transmitter disable; Transmitter laser source turned off
4	MOD_DEF(2)	LVTTL-I	Two-wire serial interface data
5	MOD_DEF(1)	LVTTL-I	Two-wire serial interface clock
6	MOD_DEF(0)		Transceiver presence, pull down to GND via 475 Ω resistor
7	Rate_select	CMOS	No connect
8	RX_LOS <sup>2</sup>	LVTTL-O	Receive loss of signal
9	V <sub>EE</sub> T	GND <sup>1</sup>	Transmit ground
10	V <sub>EE</sub> R	GND <sup>1</sup>	Receive ground
11	V <sub>EE</sub> R	GND <sup>1</sup>	Receive ground
12	RD-	CML	Receiver inverted data output
13	RD+	CML	Receiver non-inverted data output
14	V <sub>EE</sub> R	GND <sup>1</sup>	Receive ground
15	V <sub>CC</sub> R		Receive power; 3.3 V
16	V <sub>CC</sub> T		Transmit power; 3.3 V
17	V <sub>EE</sub> T	GND <sup>1</sup>	Transmit ground
18	TD+	CML	Transmitter non-inverted data input
19	TD-	CML	Transmitter inverted data input
20	V <sub>EE</sub> T	GND <sup>1</sup>	Transmit ground

1. Module ground pins (GND) are isolated from the module case and chassis ground within the module.
2. Pull up with 4.7 to 10 kΩ to a voltage between 3.15 and 3.45 V on the host board.

### 3.2 Absolute Maximum Ratings

Parameter	Symbol	Ratings	Unit
Storage temperature	T <sub>ST</sub>	-40 to +85	°C
Operating case temperature	T <sub>OP</sub>		
SFP-DAxxCS00C-xx		-5 to +70	°C
SFP-DAxxKS00C-xx		-40 to +85	°C
Relative humidity	RH	5 to 95 (noncondensing)	%
Static electrical discharge (Human Body Model)	ESD	500	V
Power supply voltages	V <sub>CC3</sub>	-0.3 to 4.0	V
Receive input optical power (damage threshold)	P <sub>dth</sub>	3	dBm

**Note:**

Absolute maximum ratings represent the device's damage threshold. Damage may occur if the device is operated above the limits stated here, except for brief excursions. Performance is not guaranteed and reliability is not implied for operation under any condition outside of the recommended operating limits.

## 7

### 3.3 Electrical Characteristics

Parameter	Symbol	Minimum	Typical	Maximum	Unit	Notes
<b>Supply currents and voltages</b>						
Supply voltage	$V_{CC}$	3.13	3.3	3.47	V	With respect to GND
Supply current	$I_{CC}$					
SFP-DAxxCS00C-xx				375	mA	
SFP-DAxxKS00C-xx				430	mA	
Power dissipation	$P_{wr}$					
SFP-DAxxCS00C-xx				1.3	W	
SFP-DAxxKS00C-xx				1.5	W	
Data rate <sup>1</sup>		100		3125	Mbps	
<b>Low-speed control and sense signals (detailed specification in SFP MSA INF8074i Rev. 1.0)</b>						
Outputs (TX_FAULT, RX_LOS)	$V_{OL}$	0		0.4	V	$R_{pullup}$ pulled to host $_V_{CC}$ , measured at host side of connector. $I_{OL(max)}=3$ mA
	$V_{OH}$	host $_V_{CC}-0.5$		host $_V_{CC}+0.3$	V	$R_{pullup}$ pulled to host $_V_{CC}$ , measured at host side of connector
Inputs (TX_DIS)	$V_{IL}$	-0.3		0.8	V	Pulled up in module to $V_{CC}$
	$V_{IH}$	2		$V_{CC}3+0.3$	V	Pulled up in module to $V_{CC}$
MOD_DEF(1) /MOD_DEF(2)	$V_{IL}$	-0.3		$V_{CC}3*0.3$	V	$R_{pullup}$ pulled to host $_V_{CC}$ , measured at SFP side of connector
	$V_{IH}$	$V_{CC}3*0.7$		$V_{CC}3+0.5$	V	$R_{pullup}$ pulled to host $_V_{CC}$ , measured at SFP side of connector
<b>High-speed signals (detailed specification in SFP MSA INF8074i Rev. 1.0)</b>						
Input data signal levels <sup>2</sup>	$DV_{IN}$	400		2400	mV	Differential voltage swing
Output data signal levels <sup>2</sup>	$DV_{OUT}$	400		800	mV	Differential voltage swing

1. Assumes a PRBS 2<sup>23</sup>-1 data pattern for bit rates equal or greater than 155 Mbps and a PRBS 2<sup>7</sup>-1 data pattern for bit rates less than 155 Mbps.

2. Internally AC coupled. Terminated into 100  $\Omega$  differential. These levels are guaranteed down to 2 dB lower than the typical receiver sensitivity for each data rate and reach.

### 3.4 Jitter Specifications

Parameter	Max	Unit	Notes
Jitter generation (peak to peak)	70	mUI(p-p)	PRBS 2 <sup>23</sup> -1 data pattern, at OC-48 data rate
Jitter generation (rms)	7	mUI(rms)	
Jitter transfer/Jitter tolerance	Compliant with Telcordia GR-253 when operated with a SONET-compliant CDR		

# 8

## 3.5 Timing Requirement of Control and Status I/O

Parameter	Symbol	Min	Max	Unit	Notes
TX_DIS assert time	t_off		20	ms	Rising edge of TX_DIS to fall of output signal below 10% of nominal
TX_DIS negate time	t_on		20	ms	Falling edge of TX_DIS to rise of output signal above 90% of nominal
Time to initialize	t_init		60	s	Upon power up or negation of TX_FAULT due to TX_DISABLE
Time to initialize after reset of TX_FAULT/INT in normal operation	t_init reset		300	ms	From negation of TX_FAULT/INT using TX_DISABLE Optical power going to 90% of final value
TX_FAULT assert time	t_fault		200	μs	Time from a fault condition to TX_FAULT assertion
TX_DISABLE for reset	t_reset	10		μs	Time TX_DISABLE must be held HIGH to reset TX_FAULT
RX_LOS assert time <sup>1</sup>	t_loss_on		100	μs	Time from loss of signal to assertion of RX_LOS
RX_LOS deassert time	t_loss_off		100	μs	Time from non-LOS condition to RX_LOS deassertion
Two-wire serial clock rate	f_serial_clock		100	kHz	

1. The RX\_LOS assert time can reach 500 μs max when the optical input power is greater than -25 dBm immediately prior to the RX\_LOS condition.

## 3.6 SFP Two-wire Interface Protocol and Management Interface

The DWDM SFP optical transceiver incorporates an SFP-compliant two-wire management interface, which is used for serial ID, digital diagnostics, and certain control functions. It is modeled on the DWDM SFP MSA Rev. 1.0 specification modified to accommodate a single two-wire interface address. Details of the protocol and interface are explicitly described in the MSA. Please refer to the MSA for design reference.

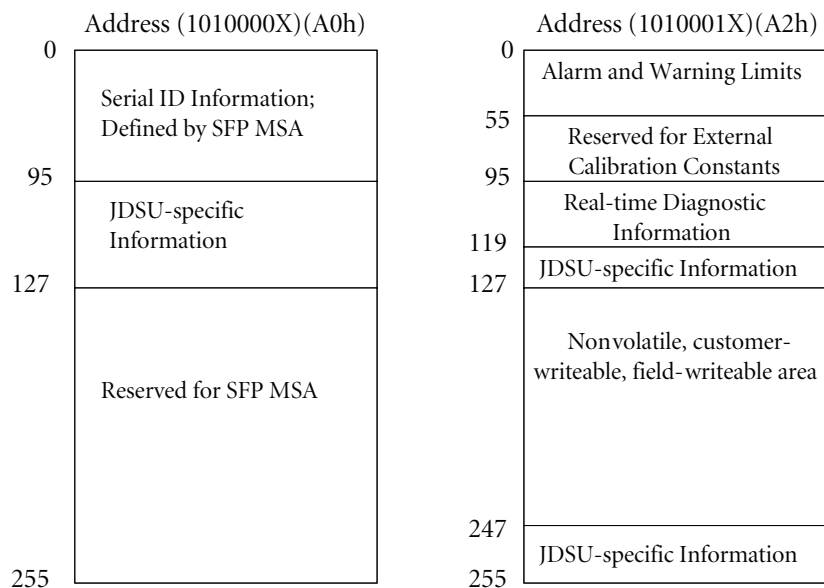

Figure 4. SFP two-wire serial digital diagnostic memory map

### 3.7 Optical Transmitter Characteristics

Parameter	Symbol	Minimum	Typical	Maximum	Unit
Average optical power (EOL)					
Long-reach transceivers	$P_{avg}$	0.0	2.0	4.0	dBm
Ultra long-reach transceivers	$P_{avg}$	3.0	5.0	7.0	dBm
Chromatic dispersion tolerance					
Long-reach transceivers	$DT_{CD}$			2400	ps/nm
Ultra long-reach transceivers	$DT_{CD}$			3600	ps/nm
Extinction ratio <sup>1</sup>	ER	8.2			dB
Optical power with transmitter disabled				-40	dBm
Center wavelength <sup>2</sup>	$\lambda_c$				
Center wavelength spacing			100		GHz
Wavelength stability (BOL)		$\lambda_c - 15$	$\lambda_c$	$\lambda_c + 15$	pm
Wavelength stability (EOL)		$\lambda_c - 100$	$\lambda_c$	$\lambda_c + 100$	pm
-20 dB spectral width	$\Delta\lambda$			0.3	nm
Sidemode suppression ratio	SSR	30			dB
Optical rise/fall time (20 – 80%)				150	ps
Optical eye mask margin <sup>3</sup>	MM	10			%
Optical path penalty ( $\leq 2.5$ G)	$P_{PATH}$			2	dB
Optical path penalty (up to 3.1 G)	$P_{PATH}$			3	dB
Optical return loss		24			dB

1. Tested with PRBS 2<sup>31</sup>-1 pattern.

2. ITU grid wavelength on p. 10.

3. Measured PRBS 2<sup>31</sup>-1 pattern; with 1000 waveforms; at OC-48 line rate.

# 10

## 3.8 Optical Receiver Characteristics

Parameter	Symbol	Minimum	Typical	Maximum	Unit
Center wavelength	$\lambda$	1260		1610	nm
Receiver sensitivity (EOL) <sup>1</sup>	$R_{sen}$		-30	-28	dBm
Receive overload <sup>1</sup>	$P_{max}$	-7			dBm
Receiver reflectance	$R_{rx}$			-27	dB
LOS assert	$P_{los\_on}$	-34		-40	dBm
LOS hysteresis		0.5		3	dB
Receiver sensitivity with presence of noise <sup>2</sup>					
B2B, OSNR = 18 dB		-22			dBm
Over fiber, OSNR = 19 dB		-22		-9	dBm

1. Measured with worst ER; BER < 10<sup>-12</sup>; PRBS 2<sup>23</sup> - 1 pattern; OSNR ≥ 28 dB.

2. OSNR measures spectral noise density over a 0.1 nm bandwidth using an optical channel filter with a 3 dB bandwidth of ≥ 0.5 nm and an optical RX wavelength between 1528 and 1565 nm.

## 3.9 Wavelength Availability

Channel	P/N Suffix (THz)	Frequency (nm)	Center Wavelength	Channel	P/N Suffix (THz)	Frequency (nm)	Center Wavelength
17	-17	191.7	1563.86	40	-40	194.0	1545.32
18	-18	191.8	1563.05	41	-41	194.1	1544.53
19	-19	191.9	1562.23	42	-42	194.2	1543.73
20	-20	192.0	1561.42	43	-43	194.3	1542.94
21	-21	192.1	1560.61	44	-44	194.4	1542.14
22	-22	192.2	1559.79	45	-45	194.5	1541.35
23	-23	192.3	1558.98	46	-46	194.6	1540.56
24	-24	192.4	1558.17	47	-47	194.7	1539.77
25	-25	192.5	1557.36	48	-48	194.8	1538.98
26	-26	192.6	1556.55	49	-49	194.9	1538.19
27	-27	193.1	1555.75	50	-50	195.0	1537.40
28	-28	192.8	1554.94	51	-51	195.1	1536.61
29	-29	192.9	1554.13	52	-52	195.2	1535.82
30	-30	193.0	1553.33	53	-53	195.3	1535.04
31	-31	193.1	1552.52	54	-54	195.4	1534.25
32	-32	193.2	1551.72	55	-55	195.5	1533.47
33	-33	193.3	1550.92	56	-56	195.6	1532.68
34	-34	193.4	1550.12	57	-57	195.7	1531.90
35	-35	193.5	1549.32	58	-58	195.8	1531.12
36	-36	193.6	1548.51	59	-59	195.9	1530.33
37	-37	193.7	1547.72	60	-60	196.0	1529.55
38	-38	193.8	1546.92	61	-61	196.1	1528.77
39	-39	193.9	1546.12				

### 3.10 Regulatory Compliance

The JDSU Optical Transceiver is confirmed as lead-free and RoHS 6/6-compliant.

The JDSU Optical Transceiver complies with international electromagnetic compatibility (EMC) and international safety requirements and standards. EMC performance depends on the overall system design. The information included herein is intended for use as a basis for design decisions and any subsequent system-level testing and certifications.

**Table 2. Regulatory Compliance**

Feature	Test Method	Performance
<b>Safety</b>		
Product safety	UL 60950-1 CSA C22.2 No. 60950-1 EN 60950-1 IEC 60950-1 Flame Class V-0  Low-Voltage Directive 2006/95/EC	UL-recognized component UL-recognized component TUV Bauart certificate CB certificate International flammability classification confirmed for printed wiring substrates and other flammable materials as required. Certified to harmonized standards listed and issued Declaration of Conformity
Laser safety	EN 60825-1 IEC 60825-1 EN 60825-2 U.S. 21 CFR 1040.10	TUV certificate TUV certificate TUV certificate FDA/CDRH certified with accession number
<b>Electromagnetic Compatibility</b>		
Radiated emissions	EMC Directive 2004/108/EC FCC Rules 47 CFR Part 15 CISPR 22 AS/NZS CISPR22 EN 55022 ICES-003, Issue 4 VCCI V-3	Class B digital device with a minimum –2 dB margin to the limit when tested in a representative host. Tested frequency range: 30 MHz to 40 GHz or 5th harmonic (5 times the highest frequency), whichever is less Requires good system EMI design practice to achieve Class B margins at the system level
Immunity	EMC Directive 2004/108/EC CISPR 24 EN 55024	
ESD	IEC/EN 61000-4-2	Exceeds requirements. Withstands discharges of ±25 kV
Radiated immunity	EN 61000-4-3	Exceeds requirements. Field strength of 10V/m from 10 MHz to 1 GHz with no detectable effect on transmitter/receiver performance between these limits.
<b>Restriction of Hazardous Substance (RoHS)</b>		
RoHS	EU Directive 2002/95/EC + EU Directive 2011/65/EU	Compliant per the Directive 2002/95/EC of the European Parliament and of the Council of 27 January 2003 and the Directive 2011/65/EU of the European Parliament and of the Council of 8 June 2011 on the restricted use of certain hazardous substances in electrical and electronic equipment. An RoHS Certificate of Conformance (C of C) is available upon request. The product may use certain RoHS exemptions.

# 12

## 3.11 Module Outline

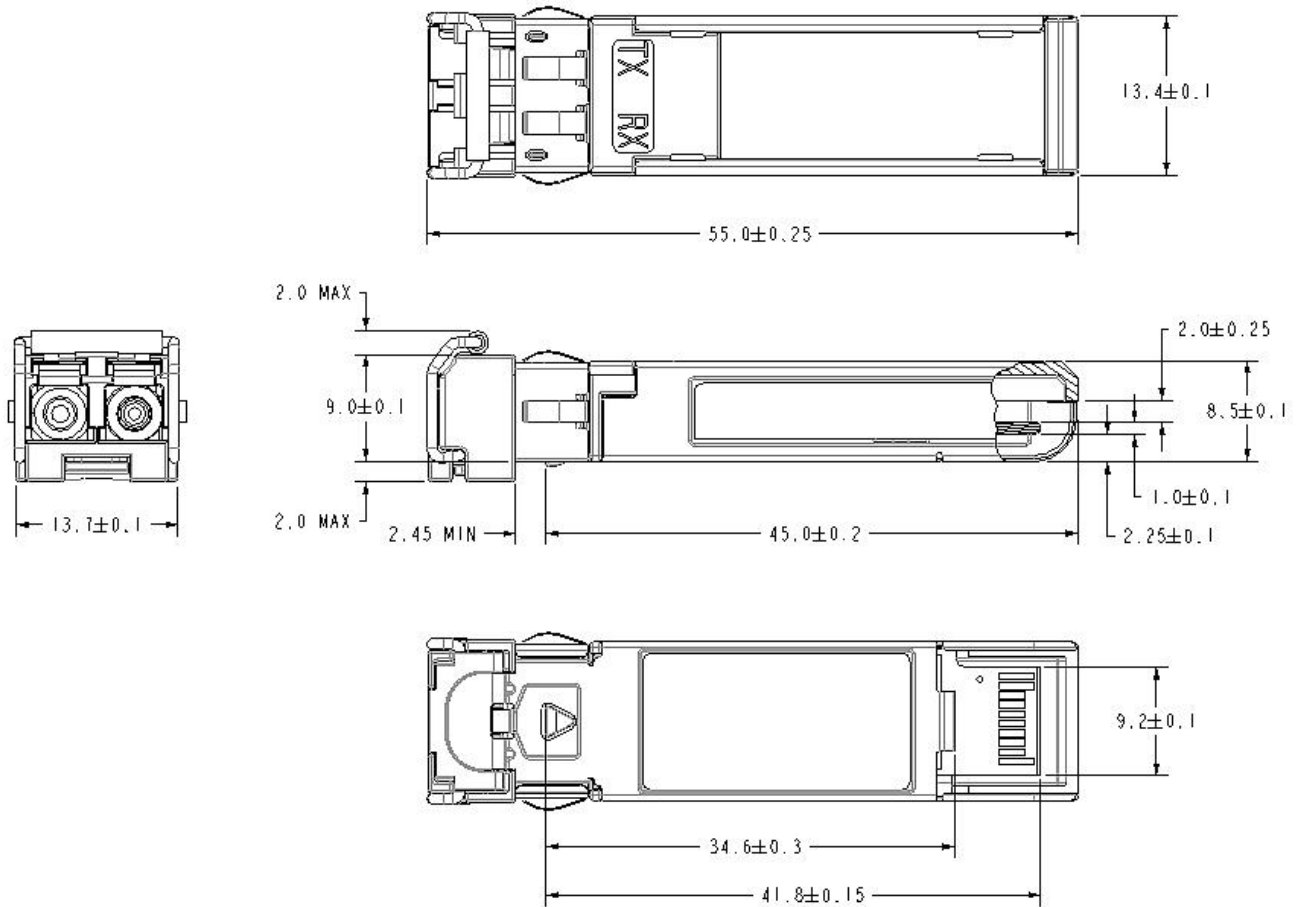

Figure 5. Module Outline

## 3.12 Connectors

### Fiber

The SFP module has a duplex LC receptacle connector.

### Electrical

The electrical connector is the 20-way, two-row PCB edge connector.

## Section 4 Related Information

Other information related to the DWDM SFP optical transceiver includes:

Section 4.1	Packing and Handling Instructions
Section 4.2	ESD Discharge (ESD)
Section 4.3	Laser Safety

### 4.1 Package and Handling Instructions

#### Connector Covers

The DWDM SFP optical transceiver is supplied with an LC duplex receptacle. The connector plug supplied protects the connector during standard manufacturing processes and handling by preventing contamination from dust, aqueous solutions, body oils, or airborne particles.

Note: The connector plug should remain on whenever the transceiver optical fiber connector is not inserted.

#### Recommended Cleaning and Degreasing Chemicals

JDSU recommends using methyl, isopropyl, and isobutyl alcohols for cleaning.

Do not use halogenated hydrocarbons (trichloroethane or ketones such as acetone, chloroform, ethyl acetate, MEK, methylene chloride, methylene dichloride, phenol, or N-methylpyrrolidone).

This product is not designed for aqueous wash.

#### Housing

The DWDM SFP optical transceiver housing is made from die-cast zinc and stainless steel sheet metal.

### 4.2 ESD Discharge (ESD)

#### Handling

Normal ESD precautions are required during the handling of this module. This transceiver is shipped in ESD protective packaging. It should be removed from the packaging and otherwise handled in an ESD-protected environment using standard grounded benches, floor mats, and wrist straps.

#### Test and Operation

In most applications, the optical connector will protrude through the system chassis and be subjected to the same ESD environment as the system. Once properly installed in the system, this transceiver should meet and exceed common ESD testing practices and fulfill system ESD requirements.

Typical of optical transceivers, this module's receiver contains a highly sensitive optical detector and amplifier that may become temporarily saturated during an ESD strike, resulting in a short burst of bit errors. Such an event might require that the application re-acquire synchronization at the higher layers (serializer/deserializer chip).

### 4.3 Laser Safety

The JDSU Optical Transceiver is certified as a Class 1 laser product per international standard IEC 60825-1:2007 2nd edition and is considered nonhazardous when operated within the limits of this specification.



**INVISIBLE LASER RADIATION  
CLASS 1 LASER PRODUCT  
per IEC 60825-1:2007  
 $\lambda = 1528\text{-}1564\text{nm}$ , <10mW**

### Caution

Operating this product in a manner inconsistent with its intended usage and specifications may result in hazardous radiation exposure.

Use of controls, adjustments, or performance of procedures other than those specified in this product data sheet may result in hazardous radiation exposure.

Tampering with this laser product or operating this product outside the limits of this specification may be considered an “act of manufacturing” and may require recertification of the modified product.

This device complies with 21 CFR 1040.10 except for deviations pursuant to Laser Notice No. 50 dated June 24, 2007.

### Ordering Information

Product Code	Description
SFP-DA56CS00C-xx	SFP DWDM 180 km SFP –5 to 70°C C-Band Transceiver
SFP-DA21CS00C-xx	SFP DWDM 120 km SFP –5 to 70°C C-Band Transceiver
SFP-DA21KS00C-xx	SFP DWDM 120 km SFP –40 to 85°C C-Band Transceiver

Note: Refer to the table in Subsection 3.9 to obtain the product code suffix that indicates the DWDM channel number for the product you wish to order. For example, for a frequency of 192.5 THz and a central wavelength of 1557.36 nm the product code suffix is –25.

### Example: SFP-DA56CS00C-25

For more information on this or other products and their availability, please contact your local JDSU account manager or JDSU directly at 1-800-498-JDSU (5378) in North America and +800-5378-JDSU worldwide, or via e-mail at [customer.service@jdsu.com](mailto:customer.service@jdsu.com).

**NORTH AMERICA: 800 498-JDSU (5378)**

**WORLDWIDE: +800 5378-JDSU**

**WEBSITE: [www.jdsu.com](http://www.jdsu.com)**