



3 GHz N N/O S.P.10T. SWITCH

OPTIONS : INDICATOR /SUPP.DIODES

R F CHARACTERISTICS

NUMBER OF WAYS : 10
 FREQUENCY RANGE : 0 - 3 GHz
 IMPEDANCE : 50 Ohms

FREQUENCY (GHz)	0 - 3
V.S.W.R <=	1.30
INSERT. LOSS <=	0.30 dB
ISOLATION >=	80 dB
AVER. POWER (*)	400 W

ELECTRICAL CHARACTERISTICS

ACTUATOR : NORMALLY OPEN
 NOMINAL CURRENT AT 25° C (±10%) : 250 mA
 ACTUATOR VOLTAGE (Vcc) : 12V (10.2 to 13V) / POSITIVE COMMON
 TERMINALS : solder pins (250 deg.C max./30 sec.)
 INDICATOR RATING : 1 W / 30 V / 100 mA

MECHANICAL CHARACTERISTICS

CONNECTORS : N female per MIL-C 39012
 LIFE : 2.000.000 cycles per position
 SWITCHING TIME (nominal voltage;25° C) : < 15 ms
 CONSTRUCTION : splashproof
 WEIGHT : < 850 g

ENVIRONMENTAL CHARACTERISTICS

OPERATING TEMPERATURE RANGE (°C) : -40 , +85
 STORAGE TEMPERATURE RANGE (°C) : -55 , +85

(* : average power at 25° C per RF path)

4112-9212 This information is given as an indication. In the continual goal to improve our products, we reserve the right to make any modifications judged necessary

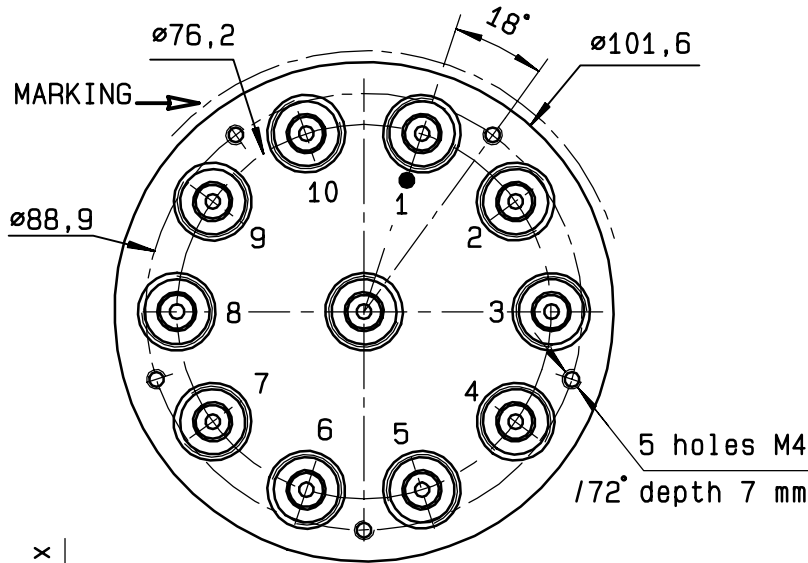

Voltage	RF continuity	Ind.
+C -1	IN ↔ 1	D.E
+C -2	IN ↔ 2	D.F
+C -3	IN ↔ 3	D.G
+C -4	IN ↔ 4	D.H
+C -5	IN ↔ 5	D.I
+C -6	IN ↔ 6	D.J
+C -7	IN ↔ 7	D.K
+C -8	IN ↔ 8	D.L
+C -9	IN ↔ 9	D.M
+C -10	IN ↔ 10	D.N

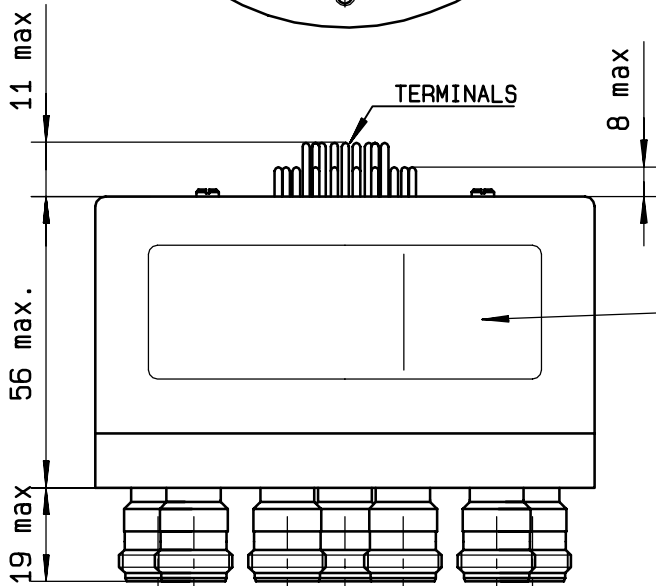

MARKING TOP VIEW (TERMINALS)

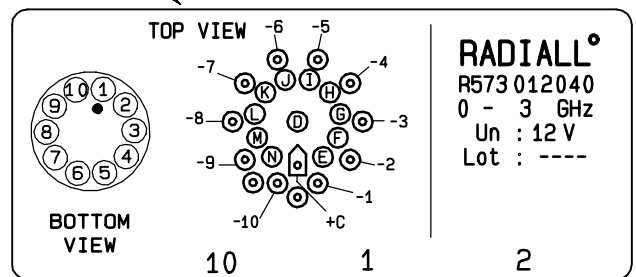

SCHEMATIC DIAGRAM

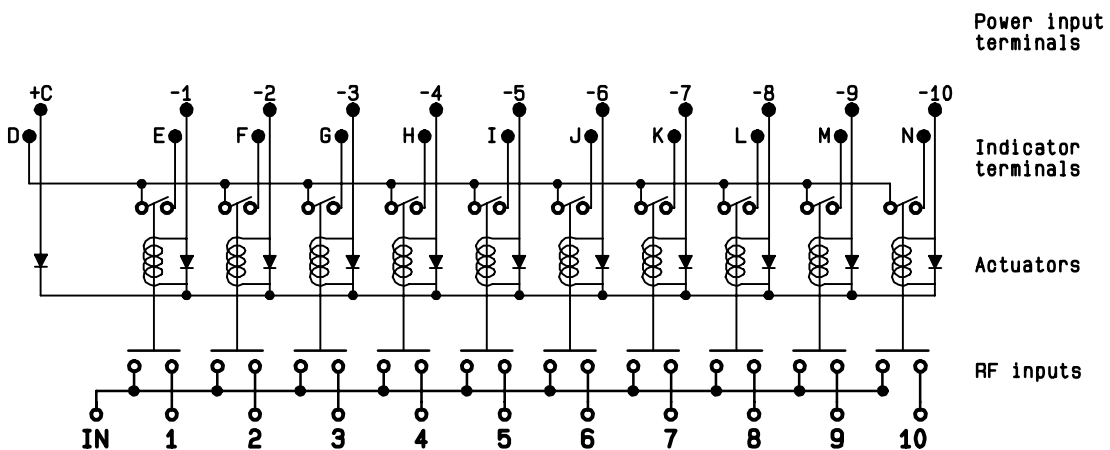

4113-9212 This information is given as an indication. In the continual goal to improve our products, we reserve the right to make any modifications judged necessary