

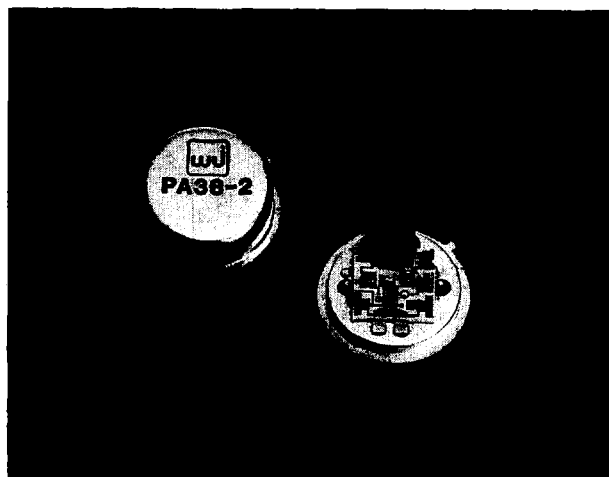

PA38-2 / SMPA38-2

200 to 2600 MHz
TO-8 CASCADABLE AMPLIFIER

- ◆ AVAILABLE IN SURFACE MOUNT
- ◆ WIDE BANDWIDTH: 200-2800 MHz (TYP.)
- ◆ HIGH OUTPUT LEVEL: +23.5 dBm (TYP.)
- ◆ GaAs FET AMPLIFIER
- ◆ HIGH THIRD ORDER INTERCEPT POINT: +33 dBm (TYP.)



Specifications*

Characteristics	Typical	Guaranteed	
		0° to -50°C	-54°C to +85°C
Frequency (Min.)	200-2800 MHz	200-2600 MHz	200-2600 MHz
Small Signal Gain (Min.)	8.5 dB	7.5 dB	7.0 dB
Gain Flatness (Max.)	±0.2 dB	±0.7 dB	±1.0 dB
Noise Figure (Max.)			
200-2600	4.5 dB	5.5 dB	6.0 dB
Power Output			
at 1 dB Compression (Min.)			
200-2000 MHz	+23.5 dBm	+22.0 dBm	+21.4 dBm
2000-2600 MHz	+22.5 dBm	+20.5 dBm	+20.0 dBm
VSWR (Max.)			
Input	1.2:1	1.9:1	2.0:1
Output	1.5:1	1.9:1	2.0:1
DC Current (Max.) at +15 Volts	150 mA	158 mA	160 mA

* Measured in a 50-ohm system at +15 Vdc Nominal.

Notes:

1. WJ-CPA38-2 is a standard WJ-PA38-2 installed in a miniature SMA connector housing and guaranteed over 0°C to 50°C temperature range.

Typical Intermodulation Performance at 25°C

Second Order Harmonic Intercept Point+55 dBm (Typ.)
 Second Order Two Tone Intercept Point+50 dBm (Typ.)
 Third Order Two Tone Intercept Point+33 dBm (Typ.)

Absolute Maximum Ratings

Storage Temperature-62°C to +125°C
 Maximum Case Temperature85°C
 Maximum DC Voltage+16 Volts
 Maximum Continuous RF Input Power+17 dBm
 Maximum Short Term RF Input Power (1 Minute Max.)100 Milliwatts
 Maximum Peak Power1 Watt (3 µsec Max.)
 "S" Series Burn-In Temperature (Case)85°C
 Proper heat sinking required to insure reliable performance.
 Weight approximately 2.0 grams (0.07 oz.)

Outline Drawings

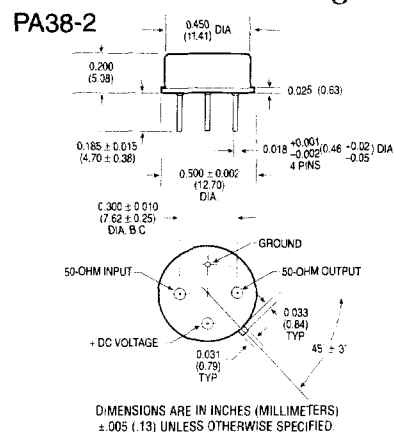

SMPA38-2

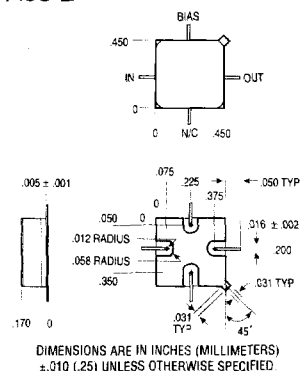

CPA38-2

See note 1

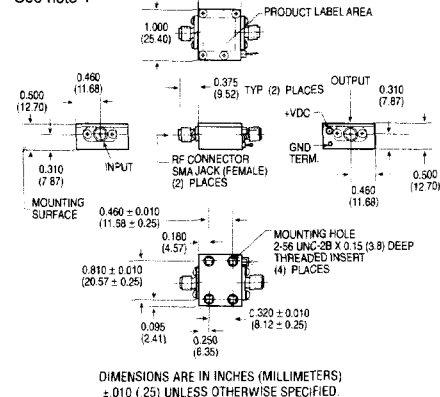

Typical Performance at 25°C

WJ-PA38-2/SMPA38-2

Gain

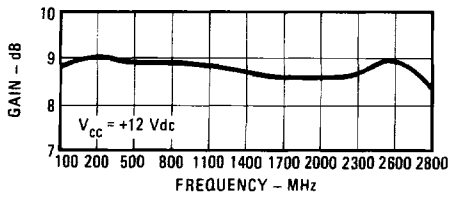
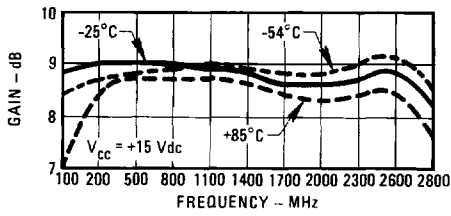

Noise Figure

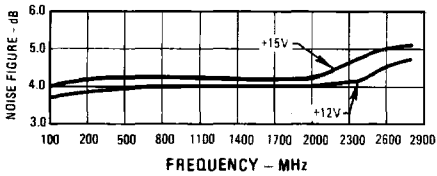

Power Output*

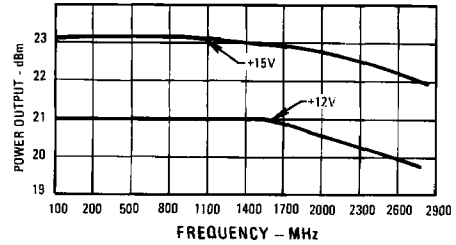
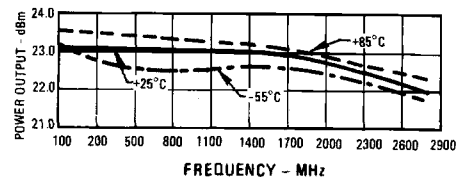

*at 1 dB Gain Compression

Intercept Point

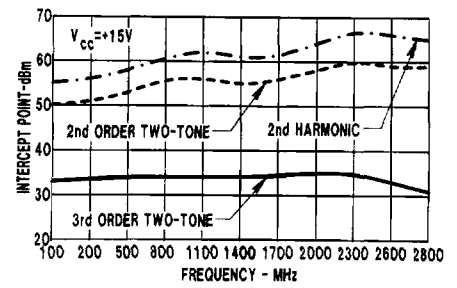

VSWR

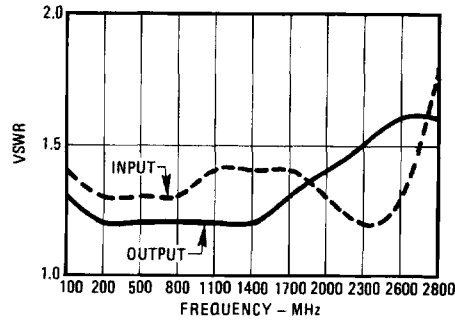

1

Typical Automatic Test Data

WJ-PA38-2/SMPA38-2

V_{CC} = 15.0 V

Frequency MHz	VSWR IN	VSWR OUT	GAIN DB
10.0	2.1	1.4	3.2
50.0	1.4	1.5	8.0
100.0	1.2	1.5	8.8
200.0	1.1	1.4	9.0
300.0	1.1	1.4	9.1
400.0	1.1	1.4	9.3
500.0	1.2	1.4	9.3
600.0	1.2	1.3	9.3
700.0	1.3	1.3	9.3
800.0	1.4	1.3	9.3
900.0	1.4	1.3	9.3
1000.0	1.5	1.3	9.3
1100.0	1.5	1.3	9.3
1200.0	1.5	1.3	9.2
1300.0	1.6	1.3	9.1
1400.0	1.5	1.3	9.0
1500.0	1.5	1.3	9.0
1600.0	1.5	1.3	9.0
1700.0	1.5	1.3	9.1
1800.0	1.5	1.3	9.0
1900.0	1.4	1.3	9.1
2000.0	1.4	1.3	9.1
2100.0	1.3	1.2	9.2
2200.0	1.2	1.2	9.4
2300.0	1.1	1.1	9.3
2400.0	1.1	1.0	9.4
2500.0	1.2	1.1	9.4
2600.0	1.4	1.3	9.2
2700.0	1.7	1.4	8.9
2800.0	2.0	1.5	8.5

V_{CC} = 12.0 V

Frequency MHz	VSWR IN	VSWR OUT	GAIN DB
10.0	2.1	1.4	3.2
50.0	1.4	1.5	8.0
100.0	1.2	1.5	8.8
200.0	1.1	1.5	9.0
300.0	1.1	1.5	9.1
400.0	1.1	1.4	9.3
500.0	1.2	1.4	9.3
600.0	1.2	1.4	9.3
700.0	1.3	1.3	9.3
800.0	1.4	1.3	9.3
900.0	1.4	1.3	9.3
1000.0	1.5	1.3	9.3
1100.0	1.5	1.3	9.3
1200.0	1.5	1.3	9.2
1300.0	1.6	1.3	9.1
1400.0	1.6	1.3	9.0
1500.0	1.6	1.3	9.1
1600.0	1.6	1.3	9.0
1700.0	1.5	1.3	9.1
1800.0	1.5	1.3	9.0
1900.0	1.4	1.2	9.2
2000.0	1.4	1.2	9.2
2100.0	1.3	1.2	9.3
2200.0	1.2	1.1	9.4
2300.0	1.1	1.0	9.4
2400.0	1.1	1.1	9.5
2500.0	1.3	1.2	9.4
2600.0	1.4	1.4	9.2
2700.0	1.6	1.5	8.9
2800.0	2.1	1.6	8.5

Linear S-Parameters

Frequency MHz	S11		S21		S12		S22	
	MAG	ANG	MAG	ANG	MAG	ANG	MAG	ANG
10.0	.350	-27	1.441	-149	.211	8	.157	-22
50.0	.175	-61	2.506	-165	.169	-10	.193	-123
100.0	.082	-73	2.743	-178	.153	-11	.196	-158
200.0	.034	-68	2.831	167	.149	-13	.184	176
300.0	.033	-20	2.839	157	.150	-17	.170	164
400.0	.055	-17	2.902	147	.148	-22	.167	158
500.0	.075	-14	2.903	137	.147	-27	.156	150
600.0	.104	-26	2.909	127	.146	-31	.142	145
700.0	.137	-40	2.917	117	.145	-36	.129	143
800.0	.159	-58	2.928	107	.144	-41	.119	142
900.0	.173	-72	2.930	98	.144	-46	.114	142
1000.0	.192	-90	2.928	87	.142	-51	.120	142
1100.0	.199	-103	2.912	78	.142	-56	.128	141
1200.0	.213	-118	2.883	68	.140	-63	.133	135
1300.0	.216	-134	2.861	59	.138	-68	.139	125
1400.0	.215	-147	2.825	49	.136	-74	.144	116
1500.0	.210	-163	2.823	39	.134	-80	.142	108
1600.0	.211	-180	2.820	30	.132	-85	.138	98
1700.0	.198	164	2.842	20	.130	-90	.137	90
1800.0	.191	147	2.822	11	.125	-95	.133	83
1900.0	.165	131	2.851	0	.123	-99	.127	77
2000.0	.153	115	2.865	-10	.124	-104	.120	71
2100.0	.115	95	2.900	-21	.124	-109	.101	67
2200.0	.091	82	2.937	-32	.126	-114	.074	60
2300.0	.054	26	2.933	-45	.127	-120	.040	58
2400.0	.050	-46	2.958	-58	.127	-126	.015	145
2500.0	.108	-105	2.967	-72	.129	-131	.069	-175
2600.0	.183	-126	2.693	-87	.129	-138	.118	-179
2700.0	.250	-147	2.798	-102	.131	-145	.163	168
2800.0	.340	-170	2.658	-118	.132	-152	.213	153

Linear S-Parameters

Frequency MHz	S11		S21		S12		S22	
	MAG	ANG	MAG	ANG	MAG	ANG	MAG	ANG
10.0	.348	-27	1.445	-150	.210	7	.175	-28
50.0	.175	-60	2.509	-165	.167	-11	.207	-124
100.0	.092	-71	2.739	-178	.151	-11	.210	-158
200.0	.035	-54	2.827	167	.146	-12	.198	175
300.0	.037	-25	2.837	157	.147	-16	.185	164
400.0	.061	-12	2.904	147	.147	-21	.181	156
500.0	.080	-16	2.908	138	.145	-26	.170	147
600.0	.107	-26	2.920	127	.144	-30	.155	141
700.0	.141	-43	2.918	117	.144	-35	.141	138
800.0	.158	-56	2.929	107	.143	-40	.127	136
900.0	.174	-73	2.925	98	.143	-44	.122	135
1000.0	.191	-87	2.929	88	.141	-49	.123	134
1100.0	.206	-104	2.904	78	.141	-54	.127	132
1200.0	.215	-117	2.887	69	.140	-60	.129	127
1300.0	.223	-132	2.858	59	.138	-66	.133	118
1400.0	.223	-147	2.835	49	.137	-72	.137	109
1500.0	.222	-161	2.838	40	.136	-77	.133	101
1600.0	.221	-179	2.811	30	.134	-82	.127	90
1700.0	.200	166	2.858	20	.133	-88	.122	83
1800.0	.200	152	2.832	11	.129	-92	.117	76
1900.0	.174	134	2.875	0	.129	-97	.106	71
2000.0	.156	117	2.878	-10	.130	-102	.097	67
2100.0	.120	93	2.911	-20	.130	-107	.073	63
2200.0	.104	75	2.944	-32	.132	-112	.045	61
2300.0	.057	40	2.951	-45	.136	-119	.016	111
2400.0	.055	-48	2.969	-58	.136	-125	.045	-179
2500.0	.111	-104	2.953	-72	.137	-131	.104	-178
2600.0	.180	-129	2.881	-86	.139	-139	.151	174
2700.0	.242	-148	2.800	-101	.139	-145	.195	160
2800.0	.346	-170	2.651	-116	.139	-153	.240	147

Thermal Data: V_{CC} = 15 Vdc

Thermal Resistance θ_{jc} 125°C/W

Transistor Power Dissipation P_D0.578 W

Junction Temperature Rise Above Case T_{jc}72°C