

The S-7235 Series is a CMOS PULSE/DTMF switchable dialer, which has a 32-digit redial memory. Input is made from keyboard or CPU.

### ■ Features

- Operating supply voltage
  - PULSE mode: 1.5 V to 5.5 V
  - DTMF mode : 2.0 V to 5.5V
- Low current consumption
  - PULSE mode: 500  $\mu$ A max. (3V)
  - DTMF mode : 1 mA max. (3V)
- Low data retention current:
  - 0.1  $\mu$ A max. (3V)
- Selectable make/break ratio of 33% and 40%
- Selectable dial speed of 10 pps and 20 pps in PULSE mode
- Selectable times for Flash (A2, B2 and F2)
- Selectable interface of 8-bit keyboard and 4-bit CPU (A2 and F2 types)
- Built-in 32-digit (or 31-digit including DTMF mode) redial memory
- 3.579545-MHz quartz crystal or ceramic oscillator
- Key-in-tone output responding to a valid key-input in PULSE mode (output time: 37.2 ms, frequency: 1.8 kHz)

### ■ Functions

- Flash
- Auto-pause
- Wait-pause
- Redialing inhibition
- Dialing inhibition
- Mixed dialing from PULSE mode to DTMF mode
- Mode selection of PULSE and DTMF modes and mode change from PULSE mode to DTMF mode

### ■ Timing Selection

Table 1

| Parameter<br>Product name | Flash time ( $t_{FL}$ )                        | Flash-pause time ( $t_{FLP}$ ) | Auto pause time ( $t_{AP}$ ) | Tone duration ( $t_{MF}$ ) (min.) | Tone inter-pause time ( $t_{TIP}$ ) (min.) |
|---------------------------|--|--------------------------------|------------------------------|-----------------------------------|--|
| S-7235A2                  | 608 ms (FTSA = high)<br>203 ms (FTSA = low)    | 1.0 s                          | 3.6 s                        | 70.9 ms                           | 81.1 ms                                    |
| S-7235B2                  | 933 ms (FTSB = high)<br>94.6 ms (FTSB = low)   | 1.0 s                          | 2.0 s                        | 84.5 ms                           | 87.9 ms                                    |
| S-7235C2                  | 933 ms   | 1.0 s                          | 2.0 s                        | 84.5 ms                           | 87.9 ms                                    |
| S-7235D2                  | 94.6 ms  | 1.0 s                          | 3.6 s                        | 84.5 ms                           | 87.9 ms                                    |
| S-7235E2                  | 608 ms   | 1.0 s                          | 3.6 s                        | 84.5 ms                           | 87.9 ms                                    |
| S-7235F2                  | 635.4 ms (FTSF = high)<br>94.6 ms (FTSF = low) | 1.0 s                          | 3.6 s                        | 70.9 ms                           | 81.1 ms                                    |
| S-7235G2                  | 608 ms   | 1.0 s                          | 3.6 s                        | 84.5 ms                           | 87.9 ms                                    |

# PULSE/DTMF SWITCHABLE DIALER S-7235 Series

## Pin Arrangement

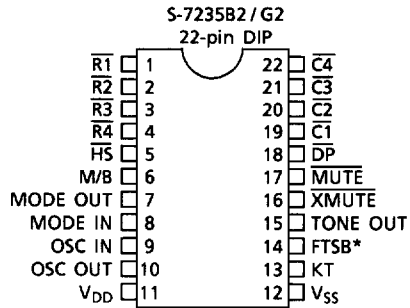
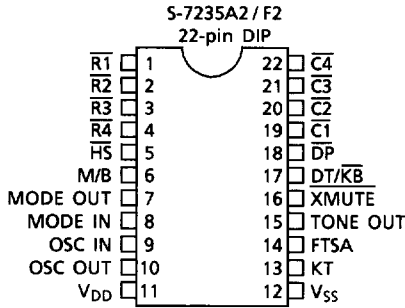

\* NC for S-7235G2

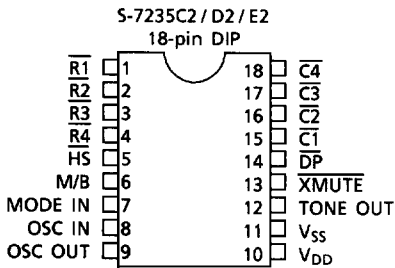
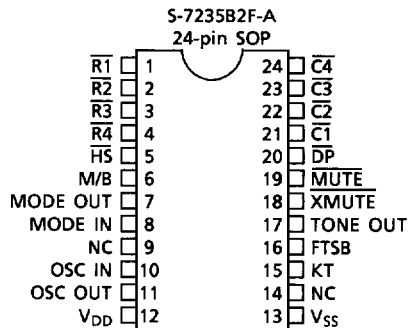
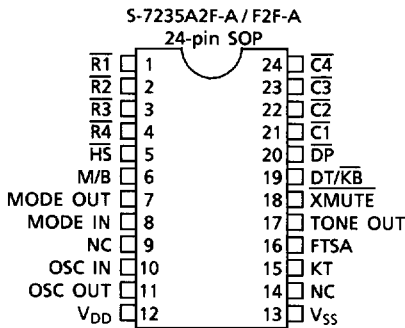

|                    |                                 |
|--------------------|---------------------------------|
| R1 to R4, C1 to C4 | Key input or scan signal output |
| H5                 | Hook switch on/off input        |
| M/B                | Make ratio selection input      |
| MODE OUT           | Operation mode output           |
| MODE IN            | Mode change input               |
| OSC IN             | Oscillator connection input     |
| OSC OUT            | Oscillator connection output    |
| DP                 | Dial pulse output               |
| DT/KB              | CPU control/keyboard input      |
| MUTE               | Mute output                     |
| XMUTE              | Transmit mute output            |
| TONE OUT           | DTMF signal output              |
| FTSA, FTSB         | Flash time selection input      |
| KT                 | Key-in-tone output              |

## Block Diagram

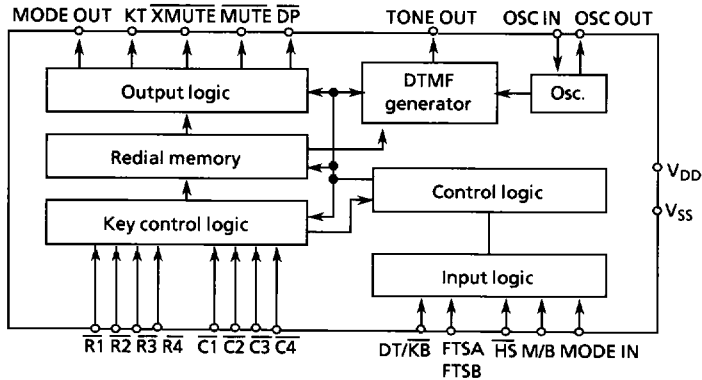

■ **Keyboard Matrix**

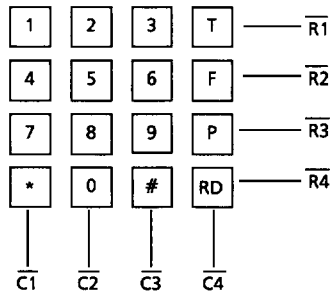

- T : PULSE mode: Mode change from PULSE to DTMF  
DTMF mode: Wait pause (Dial data ending code)
- F : Flash
- P : Auto-pause
- RD : Redial
- 0 to 9 : Data
- # , \* : Data (at DTMF mode only)

■ **Key Operation**

↑ : Off hook ( $\overline{HS} = \text{low}$ )

1. Normal dialing

- 1.1 PULSE mode (MODE IN = high or open)
- 1.2 DTMF mode (MODE IN = low)
- 1.3 DTMF mode (MODE IN = low)

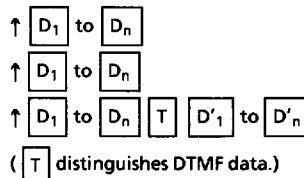

2. Mixed dialing

- 2.1 Change by  $\boxed{T}$  (MODE IN = high or open)

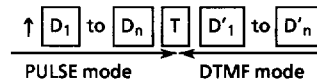

- 2.2 Change by MODE IN

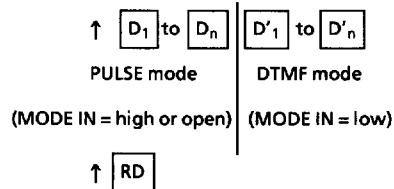

3. Redialing

Only data  $\boxed{D_1}$  to  $\boxed{D_n}$  are redialed after normal dial (when the redialing mode is returned to DTMF mode) or mixed dial.

4. Redialing inhibition



5. All redialing valid



6. Auto-pause release

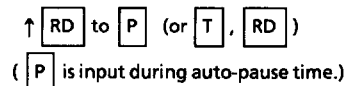

7. Wait-pause release

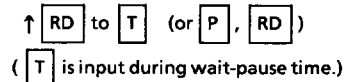

■ **Operation**

1. Normal dialing

- After Off-Hook, a mode is set up depending upon the state of MODE IN. When any key of [0] to [9] in PULSE mode, or of [0] to [9], \*, # in DTMF mode is input, a PULSE/DTMF signal corresponding to the key is output.
- Redial memory has 32 digits and [0] to [9], \*, #, P, T, F are stored in the redial memory each as one digit. Digits after the 32nd erase the old digits and rewrite the redial memory from digit 1.
- After Off-Hook, when the first key-input is [0] to [9], F in PULSE mode, [0] to [9], \*, #, F in DTMF mode, the redial memory is cleared and the key-input data is stored from digit 1 of the redial memory.
- In normal dialing in PULSE mode, the dial rate (20 pps/10 pps) is decided when a key is input to digit 1. In redialing after Off-Hook in PULSE mode, the dial rate is decided at [RD]. The dial rate is effective until it is reset by executing flash.

[ Note ] [RD] cannot be accepted in normal dialing.

2. Mode change (Mixed dialing from PULSE mode to DTMF mode)

- Mixed dialing is available from PULSE mode to DTMF mode. There are two methods as follows:
  - MODE IN is set from PULSE mode (high or open) to DTMF mode (low) and normal dialing is executed.
  - T is input when MODE IN is at PULSE mode and normal dialing is executed.
- Mode change code and data code are input to the redial memory, and then successive DTMF data is output. When returning to PULSE mode, MODE IN is set to high or open and flash is executed.

3. Redialing

- By inputting [RD] initially after Off-Hook, data in the redial memory is output. Output data is as follows:
  - PULSE data at mixed dialing ... (1)  
When F is input in PULSE data, only the data before F is redialed.
  - DTMF data from digit 1 of the redial memory to T when T is input at normal dialing in DTMF mode ... (2)  
When F is input before T, only the data before F is redialed.
  - When digit 1 of the redial memory is F in normal or mixed dialing, the data after F is output in the same way as (1) and (2) after flash execution.
- Regardless of the MODE IN state, redialed data is output in a mode of the redial memory.
- [ Complete redialing ] When [RD] is input once after normal dialing is completed, and then input it again after Off-Hook, all the data of the redial memory is output. ... (3)
- [ Redialing inhibition ] Redialing is inhibited in the following cases:
  - When the redial memory overflows: data over 33 digits in PULSE mode or 32 digits in DTMF mode is input.
  - When [RD] is input twice after normal dialing is completed. After inhibiting redialing, normal dialing can be done; its data cannot be redialed.Redialing inhibition is reset by the first normal dialing after HS is turned from high (On-Hook) to low (Off-Hook).
- [ Normal dialing after redialing ]
  - In case of (1) or (2), normal dialing data after redialing is not output at the following redialing.
  - In case of (3), normal dialing data after redialing is input after the last data of the redial memory and output at the following redialing.
  - When normal dialing data in DTMF mode is input after redialing in DTMF mode, T is input automatically between redialed data and data after redialing. At the following redialing, only the redialed data is redialed. When complete redialing mode is set, at the following redialing the redialed data is output, wait-pause is executed, and reset, and the data after redialing is redialed.

#### 4. Pause

##### 4.1 Auto-pause

- $\overline{P}$  input before normal dialing enables auto-pause. When a  $\overline{P}$  is input, an auto-pause is executed during the auto-pause time ( $t_{AP}$ ).  $\overline{P}$  can be input  $n$  times to make an auto-pause time of  $n \times t_{AP}$ .
- When all data are dialed at normal dialing, and then  $\overline{P}$  is input, auto-pause is not executed at that time but is executed at the following redialing. When  $\overline{P}$  is input during dialing,  $\overline{P}$  is dialed from the redial memory and then an auto-pause is executed.
- The first  $\overline{P}$  input after Off-Hook is ignored.
- When  $\overline{P}$ ,  $\overline{T}$  or  $\overline{RD}$  is input during executing an auto-pause or subsequent auto-pauses after redialing, the auto-pause is reset and next data is dialed.
- [ Mode change and auto-pause ] When mode change instruction from PULSE mode to DTMF mode is executed by MODE IN or  $\overline{T}$  during normal dialing (including inter-digital pause time, and auto-pause execution time), auto-pause is executed after the mode change. When mode change instruction is after normal dialing, however, auto-pause is not executed. When  $\overline{P}$  is input before or after mode change, auto-pause is executed after mode change.

##### 4.2 Wait-pause

- The following cases lead to wait-pause, which temporarily stops data dialing after mode change with MODE OUT on and off.
  - After redialing when  $\overline{P}$  is input neither before nor after mode change at mixed dialing, and  $\overline{RD}$  is input after mode change.
  - After redialing when  $\overline{P}$  is input neither before nor after mode change in DTMF mode, and  $\overline{RD}$  is input after normal dialing.
- [ Reset ]  $\overline{T}$ ,  $\overline{RD}$  or  $\overline{P}$  is input. After reset, next data is dialed.

#### 5. Flash

- $\overline{F}$  input causes On-Hook state temporarily.  $\overline{F}$  is stored in the redial memory, and when  $\overline{F}$  is dialed, flash is executed. After flash, flash-pause is executed. Flash time ( $t_{FL}$ ) is selected by FTSA or FTSB.
- During flash or flash-pause, normal dialing is valid. Input data is dialed after flash-pause.
- During flash or flash-pause, MODE OUT is off, which means it is set to PULSE mode. Normal dialing mode is reset by MODE IN after flash. After reset, data code is input in PULSE mode in the redial memory, and mode change code and data code are input in DTMF mode.

#### 6. Key-in-tone

- The key-in-tone is a sound that confirms that key-input has been executed. It is output after reading valid key-input in PULSE mode.
- Key-in-tone is not output in the following cases:
  - Key-input for releasing auto-pause or wait-pause at redialing
  - $\overline{F}$  or  $\overline{T}$  input

#### 7. Dialing inhibition

- [ Input through single-contact type keyboard ] All key-input can be inhibited by turning  $\overline{DT/KB}$  to high or  $\overline{C4}$  to low. As long as  $\overline{C4}$  is low, the oscillation circuit operates.
- [ Input through CPU ] All key-input is inhibited by turning  $\overline{R4}$  to low.
- Data input before inhibition is output during redialing in the usual way.

# PULSE/DTMF SWITCHABLE DIALER

## S-7235 Series

### Pin Functions

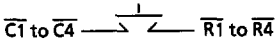
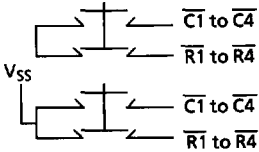
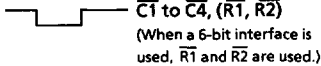
| Pin name   | Functions  |
|--|--|
| $\overline{R1}$ to $\overline{R4}$<br>$\overline{C1}$ to $\overline{C4}$ | <ul style="list-style-type: none"> <li>Key inputs. Interfaces with keyboard and with CPU are available. There are three types of keyboard: single-contact, 2 of 7, and 2 of 8. Their contact resistance is 10 k<math>\Omega</math> max.</li> </ul> <div style="display: flex; justify-content: space-around; align-items: flex-start;"> <div style="text-align: center;"> <p>Single-contact keyboard</p>  </div> <div style="text-align: center;"> <p>2 of 7 keyboard<br/>2 of 8 keyboard</p>  </div> <div style="text-align: center;"> <p>CPU</p>  <p><math>\overline{C1}</math> to <math>\overline{C4}</math>, (<math>\overline{R1}</math>, <math>\overline{R2}</math>)<br/>(When a 6-bit interface is used, R1 and R2 are used.)</p> </div> </div> <ul style="list-style-type: none"> <li>A chatter-free circuit at key-on/off is built in.<br/> Detection time: 16.9 ms typ.<br/> Allowable time lag between column and row inputs: 6 ms max.<br/> Valid key-input time: 50 ms min. (25 ms min. while oscillating circuit is running)<br/> Pause time between key-input: 25 ms min.</li> <li>Preceding key-input is valid, and simultaneous key-inputs are invalid.</li> <li>When <math>\overline{HS}</math> is high, columns and rows become high impedance. When <math>\overline{HS}</math> is low in keyboard input, columns become high and rows become low. Key-input is read by connecting columns and rows to each other in a matrix or to <math>V_{SS}</math> corresponding to input key. When <math>\overline{HS}</math> is low in CPU input, columns and rows are pulled up with 100 k<math>\Omega</math>, data is input by <math>\overline{C1}</math> to <math>\overline{C4}</math> and <math>\overline{R1}</math>, <math>\overline{R2}</math> (when 6-bit input) with code corresponding to key-code. All columns and rows become high between key input digits.</li> <li>When two keys of same column (excluding <math>\overline{C4}</math>) or same row in DTMF mode of keyboard-input are input simultaneously, single tone is output. High frequency group is output when same column, and low group when same row.</li> </ul> |
| $\overline{HS}$  | <ul style="list-style-type: none"> <li>Hook switch signal input in CMOS input<br/> <math>\overline{HS} = V_{DD}</math> : On-Hook mode<br/> <math>\overline{HS} = V_{SS}</math> : Off-Hook mode</li> <li>In On-Hook mode, inputs are inhibited and the internal circuit is initialized: key inputs, KT, TONE OUT, MODE IN, MODE OUT, <math>\overline{DP}</math>, <math>\overline{XMUTE}</math>, and <math>\overline{MUTE}</math> become high impedance.</li> <li>In Off-Hook mode, an internal voltage regulator for control of output level of DTMF signal operates and key inputs are in standby mode. Once a key is input, the oscillating circuits start to operate.</li> <li>For internal initialization in power ON, <math>\overline{HS}</math> must remain high for 1 ms or longer ( 5 ms is recommended) when <math>V_{DD}</math> is 1 V or more.</li> </ul>  |
| M/B  | <ul style="list-style-type: none"> <li>Dial pulse make/break ratio selection signal input in CMOS input<br/> <math>M/B = V_{DD}</math> : 40%<br/> <math>M/B = V_{SS}</math> : 33.3%</li> </ul>   |
| MODE OUT   | <ul style="list-style-type: none"> <li>Mode output in Nch opendrain output</li> <li>It outputs high impedance during On-Hook, in PULSE mode, during Flash or flash-pause; outputs low in DTMF mode.</li> <li>Blinks during wait-pause in redialing.<br/> Blinking frequency : 2.3 Hz typ.</li> </ul>   |
| MODE IN  | <ul style="list-style-type: none"> <li>PULSE (10 pps/20 pps)/DTMF mode selection input in CMOS input<br/> <math>MODE\ IN = V_{DD}</math> : PULSE mode 20 pps<br/> <math>MODE\ IN = open</math> : PULSE mode 10 pps<br/> (Allowable leakage resistance between MODE IN and power supply: 2 M<math>\Omega</math> or more)<br/> <math>MODE\ IN = V_{SS}</math> : DTMF mode</li> <li>When <math>\overline{HS}</math> is <math>V_{DD}</math>, MODE IN becomes high impedance.</li> <li>To prevent malfunction due to noise from telephone line circuit, connect a capacitor of 1000 pF between MODE IN and <math>V_{SS}</math>.</li> </ul>  |

**PULSE/DTMF SWITCHABLE DIALER**  
**S-7235 Series**

| Pin name                          | Functions   |                                     |    |                                |    |    |    |   |   |                            |  |         |                                   |  |                                     |  |  |  |  |  |  |  |    |    |    |    |    |    |    |    |  |   |   |   |   |   |   |   |   |   |   |   |   |   |   |   |   |   |   |   |   |   |   |   |   |   |   |   |   |   |   |   |   |   |   |   |   |   |   |   |   |   |   |   |   |   |   |   |   |   |   |   |   |   |   |   |   |   |   |   |   |   |   |   |   |   |   |   |   |   |   |   |   |   |   |   |   |   |   |   |   |   |   |   |   |   |   |   |   |   |   |   |   |   |   |   |   |   |   |   |   |   |   |   |   |   |   |   |   |   |   |   |   |   |   |   |   |   |   |   |   |   |   |   |   |   |   |   |   |   |   |   |   |   |   |   |   |   |   |   |   |   |   |   |   |   |   |   |   |   |   |   |   |   |   |   |   |   |   |   |   |   |   |   |   |   |   |   |   |   |   |   |   |   |   |   |    |   |   |   |   |   |   |   |   |   |   |                          |   |   |   |   |   |   |   |   |   |   |                          |   |   |   |   |   |   |   |   |   |   |                          |   |   |   |   |   |   |   |   |   |   |                          |   |   |   |   |   |   |   |   |   |   |                            |   |   |   |   |   |   |   |   |   |   |                            |   |   |   |   |   |   |   |   |   |   |                            |
|-----------------------------------|---|-------------------------------------|----|--------------------------------|----|----|----|---|---|----------------------------|--|---------|-----------------------------------|--|-------------------------------------|--|--|--|--|--|--|--|----|----|----|----|----|----|----|----|--|---|---|---|---|---|---|---|---|---|---|---|---|---|---|---|---|---|---|---|---|---|---|---|---|---|---|---|---|---|---|---|---|---|---|---|---|---|---|---|---|---|---|---|---|---|---|---|---|---|---|---|---|---|---|---|---|---|---|---|---|---|---|---|---|---|---|---|---|---|---|---|---|---|---|---|---|---|---|---|---|---|---|---|---|---|---|---|---|---|---|---|---|---|---|---|---|---|---|---|---|---|---|---|---|---|---|---|---|---|---|---|---|---|---|---|---|---|---|---|---|---|---|---|---|---|---|---|---|---|---|---|---|---|---|---|---|---|---|---|---|---|---|---|---|---|---|---|---|---|---|---|---|---|---|---|---|---|---|---|---|---|---|---|---|---|---|---|---|---|---|---|---|---|---|---|----|---|---|---|---|---|---|---|---|---|---|--------------------------|---|---|---|---|---|---|---|---|---|---|--------------------------|---|---|---|---|---|---|---|---|---|---|--------------------------|---|---|---|---|---|---|---|---|---|---|--------------------------|---|---|---|---|---|---|---|---|---|---|----------------------------|---|---|---|---|---|---|---|---|---|---|----------------------------|---|---|---|---|---|---|---|---|---|---|----------------------------|
| OSC IN<br>OSC OUT                 | <ul style="list-style-type: none"> <li>A 3.579545MHz quartz crystal or ceramic resonator is connected between OSC IN and OSC OUT.</li> <li>In case of ceramic resonator, 30 pF of external capacitor is required between OSC IN and V<sub>DD</sub>, and between OSC OUT and V<sub>DD</sub>.</li> </ul>  |                                     |    |                                |    |    |    |   |   |                            |  |         |                                   |  |                                     |  |  |  |  |  |  |  |    |    |    |    |    |    |    |    |  |   |   |   |   |   |   |   |   |   |   |   |   |   |   |   |   |   |   |   |   |   |   |   |   |   |   |   |   |   |   |   |   |   |   |   |   |   |   |   |   |   |   |   |   |   |   |   |   |   |   |   |   |   |   |   |   |   |   |   |   |   |   |   |   |   |   |   |   |   |   |   |   |   |   |   |   |   |   |   |   |   |   |   |   |   |   |   |   |   |   |   |   |   |   |   |   |   |   |   |   |   |   |   |   |   |   |   |   |   |   |   |   |   |   |   |   |   |   |   |   |   |   |   |   |   |   |   |   |   |   |   |   |   |   |   |   |   |   |   |   |   |   |   |   |   |   |   |   |   |   |   |   |   |   |   |   |   |   |   |   |   |   |   |   |   |   |   |   |   |   |   |   |   |   |   |    |   |   |   |   |   |   |   |   |   |   |                          |   |   |   |   |   |   |   |   |   |   |                          |   |   |   |   |   |   |   |   |   |   |                          |   |   |   |   |   |   |   |   |   |   |                          |   |   |   |   |   |   |   |   |   |   |                            |   |   |   |   |   |   |   |   |   |   |                            |   |   |   |   |   |   |   |   |   |   |                            |
| V <sub>DD</sub>                   | <ul style="list-style-type: none"> <li>Positive power supply. PULSE mode (quartz crystal) 1.5 V to 5.5 V (ceramic) 2.0 V to 5.5 V</li> <li>DTMF mode 2.0 V to 5.5 V</li> </ul>  |                                     |    |                                |    |    |    |   |   |                            |  |         |                                   |  |                                     |  |  |  |  |  |  |  |    |    |    |    |    |    |    |    |  |   |   |   |   |   |   |   |   |   |   |   |   |   |   |   |   |   |   |   |   |   |   |   |   |   |   |   |   |   |   |   |   |   |   |   |   |   |   |   |   |   |   |   |   |   |   |   |   |   |   |   |   |   |   |   |   |   |   |   |   |   |   |   |   |   |   |   |   |   |   |   |   |   |   |   |   |   |   |   |   |   |   |   |   |   |   |   |   |   |   |   |   |   |   |   |   |   |   |   |   |   |   |   |   |   |   |   |   |   |   |   |   |   |   |   |   |   |   |   |   |   |   |   |   |   |   |   |   |   |   |   |   |   |   |   |   |   |   |   |   |   |   |   |   |   |   |   |   |   |   |   |   |   |   |   |   |   |   |   |   |   |   |   |   |   |   |   |   |   |   |   |   |   |   |   |    |   |   |   |   |   |   |   |   |   |   |                          |   |   |   |   |   |   |   |   |   |   |                          |   |   |   |   |   |   |   |   |   |   |                          |   |   |   |   |   |   |   |   |   |   |                          |   |   |   |   |   |   |   |   |   |   |                            |   |   |   |   |   |   |   |   |   |   |                            |   |   |   |   |   |   |   |   |   |   |                            |
| V <sub>SS</sub>                   | <ul style="list-style-type: none"> <li>Negative power supply. Connected to GND.</li> </ul>  |                                     |    |                                |    |    |    |   |   |                            |  |         |                                   |  |                                     |  |  |  |  |  |  |  |    |    |    |    |    |    |    |    |  |   |   |   |   |   |   |   |   |   |   |   |   |   |   |   |   |   |   |   |   |   |   |   |   |   |   |   |   |   |   |   |   |   |   |   |   |   |   |   |   |   |   |   |   |   |   |   |   |   |   |   |   |   |   |   |   |   |   |   |   |   |   |   |   |   |   |   |   |   |   |   |   |   |   |   |   |   |   |   |   |   |   |   |   |   |   |   |   |   |   |   |   |   |   |   |   |   |   |   |   |   |   |   |   |   |   |   |   |   |   |   |   |   |   |   |   |   |   |   |   |   |   |   |   |   |   |   |   |   |   |   |   |   |   |   |   |   |   |   |   |   |   |   |   |   |   |   |   |   |   |   |   |   |   |   |   |   |   |   |   |   |   |   |   |   |   |   |   |   |   |   |   |   |   |   |    |   |   |   |   |   |   |   |   |   |   |                          |   |   |   |   |   |   |   |   |   |   |                          |   |   |   |   |   |   |   |   |   |   |                          |   |   |   |   |   |   |   |   |   |   |                          |   |   |   |   |   |   |   |   |   |   |                            |   |   |   |   |   |   |   |   |   |   |                            |   |   |   |   |   |   |   |   |   |   |                            |
| KT                                | <ul style="list-style-type: none"> <li>Key-in-tone output in CMOS output. The signal is output for valid key-input in PULSE mode.<br/>Output duration : 37.2 ms typ.<br/>Output frequency : 1.8 kHz (Duty ratio: 50%)</li> <li>It is in high impedance when the signal is not output.</li> </ul>  |                                     |    |                                |    |    |    |   |   |                            |  |         |                                   |  |                                     |  |  |  |  |  |  |  |    |    |    |    |    |    |    |    |  |   |   |   |   |   |   |   |   |   |   |   |   |   |   |   |   |   |   |   |   |   |   |   |   |   |   |   |   |   |   |   |   |   |   |   |   |   |   |   |   |   |   |   |   |   |   |   |   |   |   |   |   |   |   |   |   |   |   |   |   |   |   |   |   |   |   |   |   |   |   |   |   |   |   |   |   |   |   |   |   |   |   |   |   |   |   |   |   |   |   |   |   |   |   |   |   |   |   |   |   |   |   |   |   |   |   |   |   |   |   |   |   |   |   |   |   |   |   |   |   |   |   |   |   |   |   |   |   |   |   |   |   |   |   |   |   |   |   |   |   |   |   |   |   |   |   |   |   |   |   |   |   |   |   |   |   |   |   |   |   |   |   |   |   |   |   |   |   |   |   |   |   |   |   |   |    |   |   |   |   |   |   |   |   |   |   |                          |   |   |   |   |   |   |   |   |   |   |                          |   |   |   |   |   |   |   |   |   |   |                          |   |   |   |   |   |   |   |   |   |   |                          |   |   |   |   |   |   |   |   |   |   |                            |   |   |   |   |   |   |   |   |   |   |                            |   |   |   |   |   |   |   |   |   |   |                            |
| $\overline{\text{XMUTE}}$         | <ul style="list-style-type: none"> <li>Transmit mute output in Nch opendrain output.</li> <li>It outputs low in PULSE/DTMF dialing (including t<sub>PP</sub>, t<sub>TP</sub>, t<sub>DP</sub>, and t<sub>TP</sub>), and flash; it outputs high impedance in other operations.</li> </ul>   |                                     |    |                                |    |    |    |   |   |                            |  |         |                                   |  |                                     |  |  |  |  |  |  |  |    |    |    |    |    |    |    |    |  |   |   |   |   |   |   |   |   |   |   |   |   |   |   |   |   |   |   |   |   |   |   |   |   |   |   |   |   |   |   |   |   |   |   |   |   |   |   |   |   |   |   |   |   |   |   |   |   |   |   |   |   |   |   |   |   |   |   |   |   |   |   |   |   |   |   |   |   |   |   |   |   |   |   |   |   |   |   |   |   |   |   |   |   |   |   |   |   |   |   |   |   |   |   |   |   |   |   |   |   |   |   |   |   |   |   |   |   |   |   |   |   |   |   |   |   |   |   |   |   |   |   |   |   |   |   |   |   |   |   |   |   |   |   |   |   |   |   |   |   |   |   |   |   |   |   |   |   |   |   |   |   |   |   |   |   |   |   |   |   |   |   |   |   |   |   |   |   |   |   |   |   |   |   |   |    |   |   |   |   |   |   |   |   |   |   |                          |   |   |   |   |   |   |   |   |   |   |                          |   |   |   |   |   |   |   |   |   |   |                          |   |   |   |   |   |   |   |   |   |   |                          |   |   |   |   |   |   |   |   |   |   |                            |   |   |   |   |   |   |   |   |   |   |                            |   |   |   |   |   |   |   |   |   |   |                            |
| $\overline{\text{MUTE}}$          | <ul style="list-style-type: none"> <li>Mute output in Nch opendrain output.</li> <li>It outputs low in PULSE dialing (including t<sub>PP</sub> and t<sub>DP</sub>), and flash; it outputs high impedance in other operations.</li> </ul>  |                                     |    |                                |    |    |    |   |   |                            |  |         |                                   |  |                                     |  |  |  |  |  |  |  |    |    |    |    |    |    |    |    |  |   |   |   |   |   |   |   |   |   |   |   |   |   |   |   |   |   |   |   |   |   |   |   |   |   |   |   |   |   |   |   |   |   |   |   |   |   |   |   |   |   |   |   |   |   |   |   |   |   |   |   |   |   |   |   |   |   |   |   |   |   |   |   |   |   |   |   |   |   |   |   |   |   |   |   |   |   |   |   |   |   |   |   |   |   |   |   |   |   |   |   |   |   |   |   |   |   |   |   |   |   |   |   |   |   |   |   |   |   |   |   |   |   |   |   |   |   |   |   |   |   |   |   |   |   |   |   |   |   |   |   |   |   |   |   |   |   |   |   |   |   |   |   |   |   |   |   |   |   |   |   |   |   |   |   |   |   |   |   |   |   |   |   |   |   |   |   |   |   |   |   |   |   |   |   |    |   |   |   |   |   |   |   |   |   |   |                          |   |   |   |   |   |   |   |   |   |   |                          |   |   |   |   |   |   |   |   |   |   |                          |   |   |   |   |   |   |   |   |   |   |                          |   |   |   |   |   |   |   |   |   |   |                            |   |   |   |   |   |   |   |   |   |   |                            |   |   |   |   |   |   |   |   |   |   |                            |
| $\overline{\text{DP}}$            | <ul style="list-style-type: none"> <li>Dial pulse output in Nch opendrain output.</li> <li>It outputs low at break in PULSE dialing and flash; it outputs high impedance in other operations. PULSE signals are output after t<sub>PP</sub> when <math>\overline{\text{XMUTE}}</math> and <math>\overline{\text{MUTE}}</math> were low; <math>\overline{\text{XMUTE}}</math> and <math>\overline{\text{MUTE}}</math> become high impedance after t<sub>MOP1</sub> or t<sub>MOP2</sub> has passed, following the last PULSE signal transmission.</li> </ul>  |                                     |    |                                |    |    |    |   |   |                            |  |         |                                   |  |                                     |  |  |  |  |  |  |  |    |    |    |    |    |    |    |    |  |   |   |   |   |   |   |   |   |   |   |   |   |   |   |   |   |   |   |   |   |   |   |   |   |   |   |   |   |   |   |   |   |   |   |   |   |   |   |   |   |   |   |   |   |   |   |   |   |   |   |   |   |   |   |   |   |   |   |   |   |   |   |   |   |   |   |   |   |   |   |   |   |   |   |   |   |   |   |   |   |   |   |   |   |   |   |   |   |   |   |   |   |   |   |   |   |   |   |   |   |   |   |   |   |   |   |   |   |   |   |   |   |   |   |   |   |   |   |   |   |   |   |   |   |   |   |   |   |   |   |   |   |   |   |   |   |   |   |   |   |   |   |   |   |   |   |   |   |   |   |   |   |   |   |   |   |   |   |   |   |   |   |   |   |   |   |   |   |   |   |   |   |   |   |   |    |   |   |   |   |   |   |   |   |   |   |                          |   |   |   |   |   |   |   |   |   |   |                          |   |   |   |   |   |   |   |   |   |   |                          |   |   |   |   |   |   |   |   |   |   |                          |   |   |   |   |   |   |   |   |   |   |                            |   |   |   |   |   |   |   |   |   |   |                            |   |   |   |   |   |   |   |   |   |   |                            |
| TONE OUT                          | <ul style="list-style-type: none"> <li>DTMF signal output in Pch opendrain output.</li> <li>It is in high impedance when the signal is not output.</li> <li>The minimum DTMF tone duration in both redialing and normal dialing is t<sub>MF</sub>. If a key-depression in normal dialing is longer than t<sub>MF</sub>, a DTMF signal is output until the key is released.</li> </ul>   |                                     |    |                                |    |    |    |   |   |                            |  |         |                                   |  |                                     |  |  |  |  |  |  |  |    |    |    |    |    |    |    |    |  |   |   |   |   |   |   |   |   |   |   |   |   |   |   |   |   |   |   |   |   |   |   |   |   |   |   |   |   |   |   |   |   |   |   |   |   |   |   |   |   |   |   |   |   |   |   |   |   |   |   |   |   |   |   |   |   |   |   |   |   |   |   |   |   |   |   |   |   |   |   |   |   |   |   |   |   |   |   |   |   |   |   |   |   |   |   |   |   |   |   |   |   |   |   |   |   |   |   |   |   |   |   |   |   |   |   |   |   |   |   |   |   |   |   |   |   |   |   |   |   |   |   |   |   |   |   |   |   |   |   |   |   |   |   |   |   |   |   |   |   |   |   |   |   |   |   |   |   |   |   |   |   |   |   |   |   |   |   |   |   |   |   |   |   |   |   |   |   |   |   |   |   |   |   |   |    |   |   |   |   |   |   |   |   |   |   |                          |   |   |   |   |   |   |   |   |   |   |                          |   |   |   |   |   |   |   |   |   |   |                          |   |   |   |   |   |   |   |   |   |   |                          |   |   |   |   |   |   |   |   |   |   |                            |   |   |   |   |   |   |   |   |   |   |                            |   |   |   |   |   |   |   |   |   |   |                            |
| FTSA/FTSB                         | <ul style="list-style-type: none"> <li>Selection of flash time in CMOS input.</li> </ul>  |                                     |    |                                |    |    |    |   |   |                            |  |         |                                   |  |                                     |  |  |  |  |  |  |  |    |    |    |    |    |    |    |    |  |   |   |   |   |   |   |   |   |   |   |   |   |   |   |   |   |   |   |   |   |   |   |   |   |   |   |   |   |   |   |   |   |   |   |   |   |   |   |   |   |   |   |   |   |   |   |   |   |   |   |   |   |   |   |   |   |   |   |   |   |   |   |   |   |   |   |   |   |   |   |   |   |   |   |   |   |   |   |   |   |   |   |   |   |   |   |   |   |   |   |   |   |   |   |   |   |   |   |   |   |   |   |   |   |   |   |   |   |   |   |   |   |   |   |   |   |   |   |   |   |   |   |   |   |   |   |   |   |   |   |   |   |   |   |   |   |   |   |   |   |   |   |   |   |   |   |   |   |   |   |   |   |   |   |   |   |   |   |   |   |   |   |   |   |   |   |   |   |   |   |   |   |   |   |   |    |   |   |   |   |   |   |   |   |   |   |                          |   |   |   |   |   |   |   |   |   |   |                          |   |   |   |   |   |   |   |   |   |   |                          |   |   |   |   |   |   |   |   |   |   |                          |   |   |   |   |   |   |   |   |   |   |                            |   |   |   |   |   |   |   |   |   |   |                            |   |   |   |   |   |   |   |   |   |   |                            |
| DT/ $\overline{\text{KB}}$        | <ul style="list-style-type: none"> <li>Selection of interface (CPU or keyboard) in CMOS input.</li> </ul>   |                                     |    |                                |    |    |    |   |   |                            |  |         |                                   |  |                                     |  |  |  |  |  |  |  |    |    |    |    |    |    |    |    |  |   |   |   |   |   |   |   |   |   |   |   |   |   |   |   |   |   |   |   |   |   |   |   |   |   |   |   |   |   |   |   |   |   |   |   |   |   |   |   |   |   |   |   |   |   |   |   |   |   |   |   |   |   |   |   |   |   |   |   |   |   |   |   |   |   |   |   |   |   |   |   |   |   |   |   |   |   |   |   |   |   |   |   |   |   |   |   |   |   |   |   |   |   |   |   |   |   |   |   |   |   |   |   |   |   |   |   |   |   |   |   |   |   |   |   |   |   |   |   |   |   |   |   |   |   |   |   |   |   |   |   |   |   |   |   |   |   |   |   |   |   |   |   |   |   |   |   |   |   |   |   |   |   |   |   |   |   |   |   |   |   |   |   |   |   |   |   |   |   |   |   |   |   |   |   |    |   |   |   |   |   |   |   |   |   |   |                          |   |   |   |   |   |   |   |   |   |   |                          |   |   |   |   |   |   |   |   |   |   |                          |   |   |   |   |   |   |   |   |   |   |                          |   |   |   |   |   |   |   |   |   |   |                            |   |   |   |   |   |   |   |   |   |   |                            |   |   |   |   |   |   |   |   |   |   |                            |
|                                   | <table border="1"> <thead> <tr> <th colspan="2">DT/<math>\overline{\text{KB}}</math> = low</th> <th colspan="8">Interfaces with 8-bit keyboard</th> <th rowspan="3">Remarks</th> </tr> <tr> <th colspan="2">DT/<math>\overline{\text{KB}}</math> = high</th> <th colspan="8">Interfaces with CPU (usually 4-bit)</th> </tr> <tr> <th>C1</th> <th>C2</th> <th>C3</th> <th>C4</th> <th>R1</th> <th>R2</th> <th>R3</th> <th>R4</th> <th></th> </tr> </thead> <tbody> <tr><td>0</td><td>1</td><td>0</td><td>1</td><td>1</td><td>1</td><td>1</td><td>1</td><td>1</td><td>1</td><td>1</td></tr> <tr><td>1</td><td>0</td><td>0</td><td>1</td><td>1</td><td>1</td><td>1</td><td>1</td><td>1</td><td>1</td><td>2</td></tr> <tr><td>0</td><td>0</td><td>0</td><td>1</td><td>1</td><td>1</td><td>1</td><td>1</td><td>1</td><td>1</td><td>3</td></tr> <tr><td>1</td><td>1</td><td>0</td><td>1</td><td>1</td><td>1</td><td>1</td><td>1</td><td>1</td><td>1</td><td>T</td></tr> <tr><td>0</td><td>1</td><td>1</td><td>0</td><td>1</td><td>1</td><td>1</td><td>1</td><td>1</td><td>1</td><td>4</td></tr> <tr><td>1</td><td>0</td><td>1</td><td>0</td><td>1</td><td>1</td><td>1</td><td>1</td><td>1</td><td>1</td><td>5</td></tr> <tr><td>0</td><td>0</td><td>1</td><td>0</td><td>1</td><td>1</td><td>1</td><td>1</td><td>1</td><td>1</td><td>6</td></tr> <tr><td>1</td><td>1</td><td>1</td><td>0</td><td>1</td><td>1</td><td>1</td><td>1</td><td>1</td><td>1</td><td>F</td></tr> <tr><td>0</td><td>1</td><td>0</td><td>0</td><td>1</td><td>1</td><td>1</td><td>1</td><td>1</td><td>1</td><td>7</td></tr> <tr><td>1</td><td>0</td><td>0</td><td>0</td><td>1</td><td>1</td><td>1</td><td>1</td><td>1</td><td>1</td><td>8</td></tr> <tr><td>0</td><td>0</td><td>0</td><td>0</td><td>1</td><td>1</td><td>1</td><td>1</td><td>1</td><td>1</td><td>9</td></tr> <tr><td>1</td><td>1</td><td>0</td><td>0</td><td>1</td><td>1</td><td>1</td><td>1</td><td>1</td><td>1</td><td>P</td></tr> <tr><td>0</td><td>1</td><td>1</td><td>1</td><td>1</td><td>1</td><td>1</td><td>1</td><td>1</td><td>1</td><td>*</td></tr> <tr><td>1</td><td>0</td><td>1</td><td>1</td><td>1</td><td>1</td><td>1</td><td>1</td><td>1</td><td>1</td><td>0</td></tr> <tr><td>0</td><td>0</td><td>1</td><td>1</td><td>1</td><td>1</td><td>1</td><td>1</td><td>1</td><td>1</td><td>#</td></tr> <tr><td>1</td><td>1</td><td>1</td><td>1</td><td>0</td><td>1</td><td>1</td><td>1</td><td>1</td><td>1</td><td>RD</td></tr> <tr><td>1</td><td>1</td><td>0</td><td>1</td><td>1</td><td>0</td><td>1</td><td>1</td><td>1</td><td>1</td><td>Single-tone : low 697 Hz</td></tr> <tr><td>1</td><td>1</td><td>1</td><td>0</td><td>1</td><td>0</td><td>1</td><td>1</td><td>1</td><td>1</td><td>Single-tone : low 770 Hz</td></tr> <tr><td>1</td><td>1</td><td>0</td><td>0</td><td>1</td><td>0</td><td>1</td><td>1</td><td>1</td><td>1</td><td>Single-tone : low 852 Hz</td></tr> <tr><td>1</td><td>1</td><td>1</td><td>1</td><td>1</td><td>0</td><td>1</td><td>1</td><td>1</td><td>1</td><td>Single-tone : low 941 Hz</td></tr> <tr><td>0</td><td>1</td><td>1</td><td>1</td><td>1</td><td>0</td><td>1</td><td>1</td><td>1</td><td>1</td><td>Single-tone : high 1209 Hz</td></tr> <tr><td>1</td><td>0</td><td>1</td><td>1</td><td>1</td><td>0</td><td>1</td><td>1</td><td>1</td><td>1</td><td>Single-tone : high 1336 Hz</td></tr> <tr><td>0</td><td>0</td><td>1</td><td>1</td><td>1</td><td>0</td><td>1</td><td>1</td><td>1</td><td>1</td><td>Single-tone : high 1477 Hz</td></tr> </tbody> </table> | DT/ $\overline{\text{KB}}$ = low    |    | Interfaces with 8-bit keyboard |    |    |    |   |   |                            |  | Remarks | DT/ $\overline{\text{KB}}$ = high |  | Interfaces with CPU (usually 4-bit) |  |  |  |  |  |  |  | C1 | C2 | C3 | C4 | R1 | R2 | R3 | R4 |  | 0 | 1 | 0 | 1 | 1 | 1 | 1 | 1 | 1 | 1 | 1 | 1 | 0 | 0 | 1 | 1 | 1 | 1 | 1 | 1 | 1 | 2 | 0 | 0 | 0 | 1 | 1 | 1 | 1 | 1 | 1 | 1 | 3 | 1 | 1 | 0 | 1 | 1 | 1 | 1 | 1 | 1 | 1 | T | 0 | 1 | 1 | 0 | 1 | 1 | 1 | 1 | 1 | 1 | 4 | 1 | 0 | 1 | 0 | 1 | 1 | 1 | 1 | 1 | 1 | 5 | 0 | 0 | 1 | 0 | 1 | 1 | 1 | 1 | 1 | 1 | 6 | 1 | 1 | 1 | 0 | 1 | 1 | 1 | 1 | 1 | 1 | F | 0 | 1 | 0 | 0 | 1 | 1 | 1 | 1 | 1 | 1 | 7 | 1 | 0 | 0 | 0 | 1 | 1 | 1 | 1 | 1 | 1 | 8 | 0 | 0 | 0 | 0 | 1 | 1 | 1 | 1 | 1 | 1 | 9 | 1 | 1 | 0 | 0 | 1 | 1 | 1 | 1 | 1 | 1 | P | 0 | 1 | 1 | 1 | 1 | 1 | 1 | 1 | 1 | 1 | * | 1 | 0 | 1 | 1 | 1 | 1 | 1 | 1 | 1 | 1 | 0 | 0 | 0 | 1 | 1 | 1 | 1 | 1 | 1 | 1 | 1 | # | 1 | 1 | 1 | 1 | 0 | 1 | 1 | 1 | 1 | 1 | RD | 1 | 1 | 0 | 1 | 1 | 0 | 1 | 1 | 1 | 1 | Single-tone : low 697 Hz | 1 | 1 | 1 | 0 | 1 | 0 | 1 | 1 | 1 | 1 | Single-tone : low 770 Hz | 1 | 1 | 0 | 0 | 1 | 0 | 1 | 1 | 1 | 1 | Single-tone : low 852 Hz | 1 | 1 | 1 | 1 | 1 | 0 | 1 | 1 | 1 | 1 | Single-tone : low 941 Hz | 0 | 1 | 1 | 1 | 1 | 0 | 1 | 1 | 1 | 1 | Single-tone : high 1209 Hz | 1 | 0 | 1 | 1 | 1 | 0 | 1 | 1 | 1 | 1 | Single-tone : high 1336 Hz | 0 | 0 | 1 | 1 | 1 | 0 | 1 | 1 | 1 | 1 | Single-tone : high 1477 Hz |
| DT/ $\overline{\text{KB}}$ = low  |   | Interfaces with 8-bit keyboard      |    |                                |    |    |    |   |   | Remarks                    |  |         |                                   |  |                                     |  |  |  |  |  |  |  |    |    |    |    |    |    |    |    |  |   |   |   |   |   |   |   |   |   |   |   |   |   |   |   |   |   |   |   |   |   |   |   |   |   |   |   |   |   |   |   |   |   |   |   |   |   |   |   |   |   |   |   |   |   |   |   |   |   |   |   |   |   |   |   |   |   |   |   |   |   |   |   |   |   |   |   |   |   |   |   |   |   |   |   |   |   |   |   |   |   |   |   |   |   |   |   |   |   |   |   |   |   |   |   |   |   |   |   |   |   |   |   |   |   |   |   |   |   |   |   |   |   |   |   |   |   |   |   |   |   |   |   |   |   |   |   |   |   |   |   |   |   |   |   |   |   |   |   |   |   |   |   |   |   |   |   |   |   |   |   |   |   |   |   |   |   |   |   |   |   |   |   |   |   |   |   |   |   |   |   |   |   |   |   |    |   |   |   |   |   |   |   |   |   |   |                          |   |   |   |   |   |   |   |   |   |   |                          |   |   |   |   |   |   |   |   |   |   |                          |   |   |   |   |   |   |   |   |   |   |                          |   |   |   |   |   |   |   |   |   |   |                            |   |   |   |   |   |   |   |   |   |   |                            |   |   |   |   |   |   |   |   |   |   |                            |
| DT/ $\overline{\text{KB}}$ = high |   | Interfaces with CPU (usually 4-bit) |    |                                |    |    |    |   |   |                            |  |         |                                   |  |                                     |  |  |  |  |  |  |  |    |    |    |    |    |    |    |    |  |   |   |   |   |   |   |   |   |   |   |   |   |   |   |   |   |   |   |   |   |   |   |   |   |   |   |   |   |   |   |   |   |   |   |   |   |   |   |   |   |   |   |   |   |   |   |   |   |   |   |   |   |   |   |   |   |   |   |   |   |   |   |   |   |   |   |   |   |   |   |   |   |   |   |   |   |   |   |   |   |   |   |   |   |   |   |   |   |   |   |   |   |   |   |   |   |   |   |   |   |   |   |   |   |   |   |   |   |   |   |   |   |   |   |   |   |   |   |   |   |   |   |   |   |   |   |   |   |   |   |   |   |   |   |   |   |   |   |   |   |   |   |   |   |   |   |   |   |   |   |   |   |   |   |   |   |   |   |   |   |   |   |   |   |   |   |   |   |   |   |   |   |   |   |   |    |   |   |   |   |   |   |   |   |   |   |                          |   |   |   |   |   |   |   |   |   |   |                          |   |   |   |   |   |   |   |   |   |   |                          |   |   |   |   |   |   |   |   |   |   |                          |   |   |   |   |   |   |   |   |   |   |                            |   |   |   |   |   |   |   |   |   |   |                            |   |   |   |   |   |   |   |   |   |   |                            |
| C1                                | C2  | C3                                  | C4 | R1                             | R2 | R3 | R4 |   |   |                            |  |         |                                   |  |                                     |  |  |  |  |  |  |  |    |    |    |    |    |    |    |    |  |   |   |   |   |   |   |   |   |   |   |   |   |   |   |   |   |   |   |   |   |   |   |   |   |   |   |   |   |   |   |   |   |   |   |   |   |   |   |   |   |   |   |   |   |   |   |   |   |   |   |   |   |   |   |   |   |   |   |   |   |   |   |   |   |   |   |   |   |   |   |   |   |   |   |   |   |   |   |   |   |   |   |   |   |   |   |   |   |   |   |   |   |   |   |   |   |   |   |   |   |   |   |   |   |   |   |   |   |   |   |   |   |   |   |   |   |   |   |   |   |   |   |   |   |   |   |   |   |   |   |   |   |   |   |   |   |   |   |   |   |   |   |   |   |   |   |   |   |   |   |   |   |   |   |   |   |   |   |   |   |   |   |   |   |   |   |   |   |   |   |   |   |   |   |   |    |   |   |   |   |   |   |   |   |   |   |                          |   |   |   |   |   |   |   |   |   |   |                          |   |   |   |   |   |   |   |   |   |   |                          |   |   |   |   |   |   |   |   |   |   |                          |   |   |   |   |   |   |   |   |   |   |                            |   |   |   |   |   |   |   |   |   |   |                            |   |   |   |   |   |   |   |   |   |   |                            |
| 0                                 | 1   | 0                                   | 1  | 1                              | 1  | 1  | 1  | 1 | 1 | 1                          |  |         |                                   |  |                                     |  |  |  |  |  |  |  |    |    |    |    |    |    |    |    |  |   |   |   |   |   |   |   |   |   |   |   |   |   |   |   |   |   |   |   |   |   |   |   |   |   |   |   |   |   |   |   |   |   |   |   |   |   |   |   |   |   |   |   |   |   |   |   |   |   |   |   |   |   |   |   |   |   |   |   |   |   |   |   |   |   |   |   |   |   |   |   |   |   |   |   |   |   |   |   |   |   |   |   |   |   |   |   |   |   |   |   |   |   |   |   |   |   |   |   |   |   |   |   |   |   |   |   |   |   |   |   |   |   |   |   |   |   |   |   |   |   |   |   |   |   |   |   |   |   |   |   |   |   |   |   |   |   |   |   |   |   |   |   |   |   |   |   |   |   |   |   |   |   |   |   |   |   |   |   |   |   |   |   |   |   |   |   |   |   |   |   |   |   |   |   |    |   |   |   |   |   |   |   |   |   |   |                          |   |   |   |   |   |   |   |   |   |   |                          |   |   |   |   |   |   |   |   |   |   |                          |   |   |   |   |   |   |   |   |   |   |                          |   |   |   |   |   |   |   |   |   |   |                            |   |   |   |   |   |   |   |   |   |   |                            |   |   |   |   |   |   |   |   |   |   |                            |
| 1                                 | 0   | 0                                   | 1  | 1                              | 1  | 1  | 1  | 1 | 1 | 2                          |  |         |                                   |  |                                     |  |  |  |  |  |  |  |    |    |    |    |    |    |    |    |  |   |   |   |   |   |   |   |   |   |   |   |   |   |   |   |   |   |   |   |   |   |   |   |   |   |   |   |   |   |   |   |   |   |   |   |   |   |   |   |   |   |   |   |   |   |   |   |   |   |   |   |   |   |   |   |   |   |   |   |   |   |   |   |   |   |   |   |   |   |   |   |   |   |   |   |   |   |   |   |   |   |   |   |   |   |   |   |   |   |   |   |   |   |   |   |   |   |   |   |   |   |   |   |   |   |   |   |   |   |   |   |   |   |   |   |   |   |   |   |   |   |   |   |   |   |   |   |   |   |   |   |   |   |   |   |   |   |   |   |   |   |   |   |   |   |   |   |   |   |   |   |   |   |   |   |   |   |   |   |   |   |   |   |   |   |   |   |   |   |   |   |   |   |   |   |    |   |   |   |   |   |   |   |   |   |   |                          |   |   |   |   |   |   |   |   |   |   |                          |   |   |   |   |   |   |   |   |   |   |                          |   |   |   |   |   |   |   |   |   |   |                          |   |   |   |   |   |   |   |   |   |   |                            |   |   |   |   |   |   |   |   |   |   |                            |   |   |   |   |   |   |   |   |   |   |                            |
| 0                                 | 0   | 0                                   | 1  | 1                              | 1  | 1  | 1  | 1 | 1 | 3                          |  |         |                                   |  |                                     |  |  |  |  |  |  |  |    |    |    |    |    |    |    |    |  |   |   |   |   |   |   |   |   |   |   |   |   |   |   |   |   |   |   |   |   |   |   |   |   |   |   |   |   |   |   |   |   |   |   |   |   |   |   |   |   |   |   |   |   |   |   |   |   |   |   |   |   |   |   |   |   |   |   |   |   |   |   |   |   |   |   |   |   |   |   |   |   |   |   |   |   |   |   |   |   |   |   |   |   |   |   |   |   |   |   |   |   |   |   |   |   |   |   |   |   |   |   |   |   |   |   |   |   |   |   |   |   |   |   |   |   |   |   |   |   |   |   |   |   |   |   |   |   |   |   |   |   |   |   |   |   |   |   |   |   |   |   |   |   |   |   |   |   |   |   |   |   |   |   |   |   |   |   |   |   |   |   |   |   |   |   |   |   |   |   |   |   |   |   |   |    |   |   |   |   |   |   |   |   |   |   |                          |   |   |   |   |   |   |   |   |   |   |                          |   |   |   |   |   |   |   |   |   |   |                          |   |   |   |   |   |   |   |   |   |   |                          |   |   |   |   |   |   |   |   |   |   |                            |   |   |   |   |   |   |   |   |   |   |                            |   |   |   |   |   |   |   |   |   |   |                            |
| 1                                 | 1   | 0                                   | 1  | 1                              | 1  | 1  | 1  | 1 | 1 | T                          |  |         |                                   |  |                                     |  |  |  |  |  |  |  |    |    |    |    |    |    |    |    |  |   |   |   |   |   |   |   |   |   |   |   |   |   |   |   |   |   |   |   |   |   |   |   |   |   |   |   |   |   |   |   |   |   |   |   |   |   |   |   |   |   |   |   |   |   |   |   |   |   |   |   |   |   |   |   |   |   |   |   |   |   |   |   |   |   |   |   |   |   |   |   |   |   |   |   |   |   |   |   |   |   |   |   |   |   |   |   |   |   |   |   |   |   |   |   |   |   |   |   |   |   |   |   |   |   |   |   |   |   |   |   |   |   |   |   |   |   |   |   |   |   |   |   |   |   |   |   |   |   |   |   |   |   |   |   |   |   |   |   |   |   |   |   |   |   |   |   |   |   |   |   |   |   |   |   |   |   |   |   |   |   |   |   |   |   |   |   |   |   |   |   |   |   |   |   |    |   |   |   |   |   |   |   |   |   |   |                          |   |   |   |   |   |   |   |   |   |   |                          |   |   |   |   |   |   |   |   |   |   |                          |   |   |   |   |   |   |   |   |   |   |                          |   |   |   |   |   |   |   |   |   |   |                            |   |   |   |   |   |   |   |   |   |   |                            |   |   |   |   |   |   |   |   |   |   |                            |
| 0                                 | 1   | 1                                   | 0  | 1                              | 1  | 1  | 1  | 1 | 1 | 4                          |  |         |                                   |  |                                     |  |  |  |  |  |  |  |    |    |    |    |    |    |    |    |  |   |   |   |   |   |   |   |   |   |   |   |   |   |   |   |   |   |   |   |   |   |   |   |   |   |   |   |   |   |   |   |   |   |   |   |   |   |   |   |   |   |   |   |   |   |   |   |   |   |   |   |   |   |   |   |   |   |   |   |   |   |   |   |   |   |   |   |   |   |   |   |   |   |   |   |   |   |   |   |   |   |   |   |   |   |   |   |   |   |   |   |   |   |   |   |   |   |   |   |   |   |   |   |   |   |   |   |   |   |   |   |   |   |   |   |   |   |   |   |   |   |   |   |   |   |   |   |   |   |   |   |   |   |   |   |   |   |   |   |   |   |   |   |   |   |   |   |   |   |   |   |   |   |   |   |   |   |   |   |   |   |   |   |   |   |   |   |   |   |   |   |   |   |   |   |    |   |   |   |   |   |   |   |   |   |   |                          |   |   |   |   |   |   |   |   |   |   |                          |   |   |   |   |   |   |   |   |   |   |                          |   |   |   |   |   |   |   |   |   |   |                          |   |   |   |   |   |   |   |   |   |   |                            |   |   |   |   |   |   |   |   |   |   |                            |   |   |   |   |   |   |   |   |   |   |                            |
| 1                                 | 0   | 1                                   | 0  | 1                              | 1  | 1  | 1  | 1 | 1 | 5                          |  |         |                                   |  |                                     |  |  |  |  |  |  |  |    |    |    |    |    |    |    |    |  |   |   |   |   |   |   |   |   |   |   |   |   |   |   |   |   |   |   |   |   |   |   |   |   |   |   |   |   |   |   |   |   |   |   |   |   |   |   |   |   |   |   |   |   |   |   |   |   |   |   |   |   |   |   |   |   |   |   |   |   |   |   |   |   |   |   |   |   |   |   |   |   |   |   |   |   |   |   |   |   |   |   |   |   |   |   |   |   |   |   |   |   |   |   |   |   |   |   |   |   |   |   |   |   |   |   |   |   |   |   |   |   |   |   |   |   |   |   |   |   |   |   |   |   |   |   |   |   |   |   |   |   |   |   |   |   |   |   |   |   |   |   |   |   |   |   |   |   |   |   |   |   |   |   |   |   |   |   |   |   |   |   |   |   |   |   |   |   |   |   |   |   |   |   |   |    |   |   |   |   |   |   |   |   |   |   |                          |   |   |   |   |   |   |   |   |   |   |                          |   |   |   |   |   |   |   |   |   |   |                          |   |   |   |   |   |   |   |   |   |   |                          |   |   |   |   |   |   |   |   |   |   |                            |   |   |   |   |   |   |   |   |   |   |                            |   |   |   |   |   |   |   |   |   |   |                            |
| 0                                 | 0   | 1                                   | 0  | 1                              | 1  | 1  | 1  | 1 | 1 | 6                          |  |         |                                   |  |                                     |  |  |  |  |  |  |  |    |    |    |    |    |    |    |    |  |   |   |   |   |   |   |   |   |   |   |   |   |   |   |   |   |   |   |   |   |   |   |   |   |   |   |   |   |   |   |   |   |   |   |   |   |   |   |   |   |   |   |   |   |   |   |   |   |   |   |   |   |   |   |   |   |   |   |   |   |   |   |   |   |   |   |   |   |   |   |   |   |   |   |   |   |   |   |   |   |   |   |   |   |   |   |   |   |   |   |   |   |   |   |   |   |   |   |   |   |   |   |   |   |   |   |   |   |   |   |   |   |   |   |   |   |   |   |   |   |   |   |   |   |   |   |   |   |   |   |   |   |   |   |   |   |   |   |   |   |   |   |   |   |   |   |   |   |   |   |   |   |   |   |   |   |   |   |   |   |   |   |   |   |   |   |   |   |   |   |   |   |   |   |   |    |   |   |   |   |   |   |   |   |   |   |                          |   |   |   |   |   |   |   |   |   |   |                          |   |   |   |   |   |   |   |   |   |   |                          |   |   |   |   |   |   |   |   |   |   |                          |   |   |   |   |   |   |   |   |   |   |                            |   |   |   |   |   |   |   |   |   |   |                            |   |   |   |   |   |   |   |   |   |   |                            |
| 1                                 | 1   | 1                                   | 0  | 1                              | 1  | 1  | 1  | 1 | 1 | F                          |  |         |                                   |  |                                     |  |  |  |  |  |  |  |    |    |    |    |    |    |    |    |  |   |   |   |   |   |   |   |   |   |   |   |   |   |   |   |   |   |   |   |   |   |   |   |   |   |   |   |   |   |   |   |   |   |   |   |   |   |   |   |   |   |   |   |   |   |   |   |   |   |   |   |   |   |   |   |   |   |   |   |   |   |   |   |   |   |   |   |   |   |   |   |   |   |   |   |   |   |   |   |   |   |   |   |   |   |   |   |   |   |   |   |   |   |   |   |   |   |   |   |   |   |   |   |   |   |   |   |   |   |   |   |   |   |   |   |   |   |   |   |   |   |   |   |   |   |   |   |   |   |   |   |   |   |   |   |   |   |   |   |   |   |   |   |   |   |   |   |   |   |   |   |   |   |   |   |   |   |   |   |   |   |   |   |   |   |   |   |   |   |   |   |   |   |   |   |    |   |   |   |   |   |   |   |   |   |   |                          |   |   |   |   |   |   |   |   |   |   |                          |   |   |   |   |   |   |   |   |   |   |                          |   |   |   |   |   |   |   |   |   |   |                          |   |   |   |   |   |   |   |   |   |   |                            |   |   |   |   |   |   |   |   |   |   |                            |   |   |   |   |   |   |   |   |   |   |                            |
| 0                                 | 1   | 0                                   | 0  | 1                              | 1  | 1  | 1  | 1 | 1 | 7                          |  |         |                                   |  |                                     |  |  |  |  |  |  |  |    |    |    |    |    |    |    |    |  |   |   |   |   |   |   |   |   |   |   |   |   |   |   |   |   |   |   |   |   |   |   |   |   |   |   |   |   |   |   |   |   |   |   |   |   |   |   |   |   |   |   |   |   |   |   |   |   |   |   |   |   |   |   |   |   |   |   |   |   |   |   |   |   |   |   |   |   |   |   |   |   |   |   |   |   |   |   |   |   |   |   |   |   |   |   |   |   |   |   |   |   |   |   |   |   |   |   |   |   |   |   |   |   |   |   |   |   |   |   |   |   |   |   |   |   |   |   |   |   |   |   |   |   |   |   |   |   |   |   |   |   |   |   |   |   |   |   |   |   |   |   |   |   |   |   |   |   |   |   |   |   |   |   |   |   |   |   |   |   |   |   |   |   |   |   |   |   |   |   |   |   |   |   |   |    |   |   |   |   |   |   |   |   |   |   |                          |   |   |   |   |   |   |   |   |   |   |                          |   |   |   |   |   |   |   |   |   |   |                          |   |   |   |   |   |   |   |   |   |   |                          |   |   |   |   |   |   |   |   |   |   |                            |   |   |   |   |   |   |   |   |   |   |                            |   |   |   |   |   |   |   |   |   |   |                            |
| 1                                 | 0   | 0                                   | 0  | 1                              | 1  | 1  | 1  | 1 | 1 | 8                          |  |         |                                   |  |                                     |  |  |  |  |  |  |  |    |    |    |    |    |    |    |    |  |   |   |   |   |   |   |   |   |   |   |   |   |   |   |   |   |   |   |   |   |   |   |   |   |   |   |   |   |   |   |   |   |   |   |   |   |   |   |   |   |   |   |   |   |   |   |   |   |   |   |   |   |   |   |   |   |   |   |   |   |   |   |   |   |   |   |   |   |   |   |   |   |   |   |   |   |   |   |   |   |   |   |   |   |   |   |   |   |   |   |   |   |   |   |   |   |   |   |   |   |   |   |   |   |   |   |   |   |   |   |   |   |   |   |   |   |   |   |   |   |   |   |   |   |   |   |   |   |   |   |   |   |   |   |   |   |   |   |   |   |   |   |   |   |   |   |   |   |   |   |   |   |   |   |   |   |   |   |   |   |   |   |   |   |   |   |   |   |   |   |   |   |   |   |   |    |   |   |   |   |   |   |   |   |   |   |                          |   |   |   |   |   |   |   |   |   |   |                          |   |   |   |   |   |   |   |   |   |   |                          |   |   |   |   |   |   |   |   |   |   |                          |   |   |   |   |   |   |   |   |   |   |                            |   |   |   |   |   |   |   |   |   |   |                            |   |   |   |   |   |   |   |   |   |   |                            |
| 0                                 | 0   | 0                                   | 0  | 1                              | 1  | 1  | 1  | 1 | 1 | 9                          |  |         |                                   |  |                                     |  |  |  |  |  |  |  |    |    |    |    |    |    |    |    |  |   |   |   |   |   |   |   |   |   |   |   |   |   |   |   |   |   |   |   |   |   |   |   |   |   |   |   |   |   |   |   |   |   |   |   |   |   |   |   |   |   |   |   |   |   |   |   |   |   |   |   |   |   |   |   |   |   |   |   |   |   |   |   |   |   |   |   |   |   |   |   |   |   |   |   |   |   |   |   |   |   |   |   |   |   |   |   |   |   |   |   |   |   |   |   |   |   |   |   |   |   |   |   |   |   |   |   |   |   |   |   |   |   |   |   |   |   |   |   |   |   |   |   |   |   |   |   |   |   |   |   |   |   |   |   |   |   |   |   |   |   |   |   |   |   |   |   |   |   |   |   |   |   |   |   |   |   |   |   |   |   |   |   |   |   |   |   |   |   |   |   |   |   |   |   |    |   |   |   |   |   |   |   |   |   |   |                          |   |   |   |   |   |   |   |   |   |   |                          |   |   |   |   |   |   |   |   |   |   |                          |   |   |   |   |   |   |   |   |   |   |                          |   |   |   |   |   |   |   |   |   |   |                            |   |   |   |   |   |   |   |   |   |   |                            |   |   |   |   |   |   |   |   |   |   |                            |
| 1                                 | 1   | 0                                   | 0  | 1                              | 1  | 1  | 1  | 1 | 1 | P                          |  |         |                                   |  |                                     |  |  |  |  |  |  |  |    |    |    |    |    |    |    |    |  |   |   |   |   |   |   |   |   |   |   |   |   |   |   |   |   |   |   |   |   |   |   |   |   |   |   |   |   |   |   |   |   |   |   |   |   |   |   |   |   |   |   |   |   |   |   |   |   |   |   |   |   |   |   |   |   |   |   |   |   |   |   |   |   |   |   |   |   |   |   |   |   |   |   |   |   |   |   |   |   |   |   |   |   |   |   |   |   |   |   |   |   |   |   |   |   |   |   |   |   |   |   |   |   |   |   |   |   |   |   |   |   |   |   |   |   |   |   |   |   |   |   |   |   |   |   |   |   |   |   |   |   |   |   |   |   |   |   |   |   |   |   |   |   |   |   |   |   |   |   |   |   |   |   |   |   |   |   |   |   |   |   |   |   |   |   |   |   |   |   |   |   |   |   |   |    |   |   |   |   |   |   |   |   |   |   |                          |   |   |   |   |   |   |   |   |   |   |                          |   |   |   |   |   |   |   |   |   |   |                          |   |   |   |   |   |   |   |   |   |   |                          |   |   |   |   |   |   |   |   |   |   |                            |   |   |   |   |   |   |   |   |   |   |                            |   |   |   |   |   |   |   |   |   |   |                            |
| 0                                 | 1   | 1                                   | 1  | 1                              | 1  | 1  | 1  | 1 | 1 | *                          |  |         |                                   |  |                                     |  |  |  |  |  |  |  |    |    |    |    |    |    |    |    |  |   |   |   |   |   |   |   |   |   |   |   |   |   |   |   |   |   |   |   |   |   |   |   |   |   |   |   |   |   |   |   |   |   |   |   |   |   |   |   |   |   |   |   |   |   |   |   |   |   |   |   |   |   |   |   |   |   |   |   |   |   |   |   |   |   |   |   |   |   |   |   |   |   |   |   |   |   |   |   |   |   |   |   |   |   |   |   |   |   |   |   |   |   |   |   |   |   |   |   |   |   |   |   |   |   |   |   |   |   |   |   |   |   |   |   |   |   |   |   |   |   |   |   |   |   |   |   |   |   |   |   |   |   |   |   |   |   |   |   |   |   |   |   |   |   |   |   |   |   |   |   |   |   |   |   |   |   |   |   |   |   |   |   |   |   |   |   |   |   |   |   |   |   |   |   |    |   |   |   |   |   |   |   |   |   |   |                          |   |   |   |   |   |   |   |   |   |   |                          |   |   |   |   |   |   |   |   |   |   |                          |   |   |   |   |   |   |   |   |   |   |                          |   |   |   |   |   |   |   |   |   |   |                            |   |   |   |   |   |   |   |   |   |   |                            |   |   |   |   |   |   |   |   |   |   |                            |
| 1                                 | 0   | 1                                   | 1  | 1                              | 1  | 1  | 1  | 1 | 1 | 0                          |  |         |                                   |  |                                     |  |  |  |  |  |  |  |    |    |    |    |    |    |    |    |  |   |   |   |   |   |   |   |   |   |   |   |   |   |   |   |   |   |   |   |   |   |   |   |   |   |   |   |   |   |   |   |   |   |   |   |   |   |   |   |   |   |   |   |   |   |   |   |   |   |   |   |   |   |   |   |   |   |   |   |   |   |   |   |   |   |   |   |   |   |   |   |   |   |   |   |   |   |   |   |   |   |   |   |   |   |   |   |   |   |   |   |   |   |   |   |   |   |   |   |   |   |   |   |   |   |   |   |   |   |   |   |   |   |   |   |   |   |   |   |   |   |   |   |   |   |   |   |   |   |   |   |   |   |   |   |   |   |   |   |   |   |   |   |   |   |   |   |   |   |   |   |   |   |   |   |   |   |   |   |   |   |   |   |   |   |   |   |   |   |   |   |   |   |   |   |    |   |   |   |   |   |   |   |   |   |   |                          |   |   |   |   |   |   |   |   |   |   |                          |   |   |   |   |   |   |   |   |   |   |                          |   |   |   |   |   |   |   |   |   |   |                          |   |   |   |   |   |   |   |   |   |   |                            |   |   |   |   |   |   |   |   |   |   |                            |   |   |   |   |   |   |   |   |   |   |                            |
| 0                                 | 0   | 1                                   | 1  | 1                              | 1  | 1  | 1  | 1 | 1 | #                          |  |         |                                   |  |                                     |  |  |  |  |  |  |  |    |    |    |    |    |    |    |    |  |   |   |   |   |   |   |   |   |   |   |   |   |   |   |   |   |   |   |   |   |   |   |   |   |   |   |   |   |   |   |   |   |   |   |   |   |   |   |   |   |   |   |   |   |   |   |   |   |   |   |   |   |   |   |   |   |   |   |   |   |   |   |   |   |   |   |   |   |   |   |   |   |   |   |   |   |   |   |   |   |   |   |   |   |   |   |   |   |   |   |   |   |   |   |   |   |   |   |   |   |   |   |   |   |   |   |   |   |   |   |   |   |   |   |   |   |   |   |   |   |   |   |   |   |   |   |   |   |   |   |   |   |   |   |   |   |   |   |   |   |   |   |   |   |   |   |   |   |   |   |   |   |   |   |   |   |   |   |   |   |   |   |   |   |   |   |   |   |   |   |   |   |   |   |   |    |   |   |   |   |   |   |   |   |   |   |                          |   |   |   |   |   |   |   |   |   |   |                          |   |   |   |   |   |   |   |   |   |   |                          |   |   |   |   |   |   |   |   |   |   |                          |   |   |   |   |   |   |   |   |   |   |                            |   |   |   |   |   |   |   |   |   |   |                            |   |   |   |   |   |   |   |   |   |   |                            |
| 1                                 | 1   | 1                                   | 1  | 0                              | 1  | 1  | 1  | 1 | 1 | RD                         |  |         |                                   |  |                                     |  |  |  |  |  |  |  |    |    |    |    |    |    |    |    |  |   |   |   |   |   |   |   |   |   |   |   |   |   |   |   |   |   |   |   |   |   |   |   |   |   |   |   |   |   |   |   |   |   |   |   |   |   |   |   |   |   |   |   |   |   |   |   |   |   |   |   |   |   |   |   |   |   |   |   |   |   |   |   |   |   |   |   |   |   |   |   |   |   |   |   |   |   |   |   |   |   |   |   |   |   |   |   |   |   |   |   |   |   |   |   |   |   |   |   |   |   |   |   |   |   |   |   |   |   |   |   |   |   |   |   |   |   |   |   |   |   |   |   |   |   |   |   |   |   |   |   |   |   |   |   |   |   |   |   |   |   |   |   |   |   |   |   |   |   |   |   |   |   |   |   |   |   |   |   |   |   |   |   |   |   |   |   |   |   |   |   |   |   |   |   |    |   |   |   |   |   |   |   |   |   |   |                          |   |   |   |   |   |   |   |   |   |   |                          |   |   |   |   |   |   |   |   |   |   |                          |   |   |   |   |   |   |   |   |   |   |                          |   |   |   |   |   |   |   |   |   |   |                            |   |   |   |   |   |   |   |   |   |   |                            |   |   |   |   |   |   |   |   |   |   |                            |
| 1                                 | 1   | 0                                   | 1  | 1                              | 0  | 1  | 1  | 1 | 1 | Single-tone : low 697 Hz   |  |         |                                   |  |                                     |  |  |  |  |  |  |  |    |    |    |    |    |    |    |    |  |   |   |   |   |   |   |   |   |   |   |   |   |   |   |   |   |   |   |   |   |   |   |   |   |   |   |   |   |   |   |   |   |   |   |   |   |   |   |   |   |   |   |   |   |   |   |   |   |   |   |   |   |   |   |   |   |   |   |   |   |   |   |   |   |   |   |   |   |   |   |   |   |   |   |   |   |   |   |   |   |   |   |   |   |   |   |   |   |   |   |   |   |   |   |   |   |   |   |   |   |   |   |   |   |   |   |   |   |   |   |   |   |   |   |   |   |   |   |   |   |   |   |   |   |   |   |   |   |   |   |   |   |   |   |   |   |   |   |   |   |   |   |   |   |   |   |   |   |   |   |   |   |   |   |   |   |   |   |   |   |   |   |   |   |   |   |   |   |   |   |   |   |   |   |   |    |   |   |   |   |   |   |   |   |   |   |                          |   |   |   |   |   |   |   |   |   |   |                          |   |   |   |   |   |   |   |   |   |   |                          |   |   |   |   |   |   |   |   |   |   |                          |   |   |   |   |   |   |   |   |   |   |                            |   |   |   |   |   |   |   |   |   |   |                            |   |   |   |   |   |   |   |   |   |   |                            |
| 1                                 | 1   | 1                                   | 0  | 1                              | 0  | 1  | 1  | 1 | 1 | Single-tone : low 770 Hz   |  |         |                                   |  |                                     |  |  |  |  |  |  |  |    |    |    |    |    |    |    |    |  |   |   |   |   |   |   |   |   |   |   |   |   |   |   |   |   |   |   |   |   |   |   |   |   |   |   |   |   |   |   |   |   |   |   |   |   |   |   |   |   |   |   |   |   |   |   |   |   |   |   |   |   |   |   |   |   |   |   |   |   |   |   |   |   |   |   |   |   |   |   |   |   |   |   |   |   |   |   |   |   |   |   |   |   |   |   |   |   |   |   |   |   |   |   |   |   |   |   |   |   |   |   |   |   |   |   |   |   |   |   |   |   |   |   |   |   |   |   |   |   |   |   |   |   |   |   |   |   |   |   |   |   |   |   |   |   |   |   |   |   |   |   |   |   |   |   |   |   |   |   |   |   |   |   |   |   |   |   |   |   |   |   |   |   |   |   |   |   |   |   |   |   |   |   |   |    |   |   |   |   |   |   |   |   |   |   |                          |   |   |   |   |   |   |   |   |   |   |                          |   |   |   |   |   |   |   |   |   |   |                          |   |   |   |   |   |   |   |   |   |   |                          |   |   |   |   |   |   |   |   |   |   |                            |   |   |   |   |   |   |   |   |   |   |                            |   |   |   |   |   |   |   |   |   |   |                            |
| 1                                 | 1   | 0                                   | 0  | 1                              | 0  | 1  | 1  | 1 | 1 | Single-tone : low 852 Hz   |  |         |                                   |  |                                     |  |  |  |  |  |  |  |    |    |    |    |    |    |    |    |  |   |   |   |   |   |   |   |   |   |   |   |   |   |   |   |   |   |   |   |   |   |   |   |   |   |   |   |   |   |   |   |   |   |   |   |   |   |   |   |   |   |   |   |   |   |   |   |   |   |   |   |   |   |   |   |   |   |   |   |   |   |   |   |   |   |   |   |   |   |   |   |   |   |   |   |   |   |   |   |   |   |   |   |   |   |   |   |   |   |   |   |   |   |   |   |   |   |   |   |   |   |   |   |   |   |   |   |   |   |   |   |   |   |   |   |   |   |   |   |   |   |   |   |   |   |   |   |   |   |   |   |   |   |   |   |   |   |   |   |   |   |   |   |   |   |   |   |   |   |   |   |   |   |   |   |   |   |   |   |   |   |   |   |   |   |   |   |   |   |   |   |   |   |   |   |    |   |   |   |   |   |   |   |   |   |   |                          |   |   |   |   |   |   |   |   |   |   |                          |   |   |   |   |   |   |   |   |   |   |                          |   |   |   |   |   |   |   |   |   |   |                          |   |   |   |   |   |   |   |   |   |   |                            |   |   |   |   |   |   |   |   |   |   |                            |   |   |   |   |   |   |   |   |   |   |                            |
| 1                                 | 1   | 1                                   | 1  | 1                              | 0  | 1  | 1  | 1 | 1 | Single-tone : low 941 Hz   |  |         |                                   |  |                                     |  |  |  |  |  |  |  |    |    |    |    |    |    |    |    |  |   |   |   |   |   |   |   |   |   |   |   |   |   |   |   |   |   |   |   |   |   |   |   |   |   |   |   |   |   |   |   |   |   |   |   |   |   |   |   |   |   |   |   |   |   |   |   |   |   |   |   |   |   |   |   |   |   |   |   |   |   |   |   |   |   |   |   |   |   |   |   |   |   |   |   |   |   |   |   |   |   |   |   |   |   |   |   |   |   |   |   |   |   |   |   |   |   |   |   |   |   |   |   |   |   |   |   |   |   |   |   |   |   |   |   |   |   |   |   |   |   |   |   |   |   |   |   |   |   |   |   |   |   |   |   |   |   |   |   |   |   |   |   |   |   |   |   |   |   |   |   |   |   |   |   |   |   |   |   |   |   |   |   |   |   |   |   |   |   |   |   |   |   |   |   |    |   |   |   |   |   |   |   |   |   |   |                          |   |   |   |   |   |   |   |   |   |   |                          |   |   |   |   |   |   |   |   |   |   |                          |   |   |   |   |   |   |   |   |   |   |                          |   |   |   |   |   |   |   |   |   |   |                            |   |   |   |   |   |   |   |   |   |   |                            |   |   |   |   |   |   |   |   |   |   |                            |
| 0                                 | 1   | 1                                   | 1  | 1                              | 0  | 1  | 1  | 1 | 1 | Single-tone : high 1209 Hz |  |         |                                   |  |                                     |  |  |  |  |  |  |  |    |    |    |    |    |    |    |    |  |   |   |   |   |   |   |   |   |   |   |   |   |   |   |   |   |   |   |   |   |   |   |   |   |   |   |   |   |   |   |   |   |   |   |   |   |   |   |   |   |   |   |   |   |   |   |   |   |   |   |   |   |   |   |   |   |   |   |   |   |   |   |   |   |   |   |   |   |   |   |   |   |   |   |   |   |   |   |   |   |   |   |   |   |   |   |   |   |   |   |   |   |   |   |   |   |   |   |   |   |   |   |   |   |   |   |   |   |   |   |   |   |   |   |   |   |   |   |   |   |   |   |   |   |   |   |   |   |   |   |   |   |   |   |   |   |   |   |   |   |   |   |   |   |   |   |   |   |   |   |   |   |   |   |   |   |   |   |   |   |   |   |   |   |   |   |   |   |   |   |   |   |   |   |   |    |   |   |   |   |   |   |   |   |   |   |                          |   |   |   |   |   |   |   |   |   |   |                          |   |   |   |   |   |   |   |   |   |   |                          |   |   |   |   |   |   |   |   |   |   |                          |   |   |   |   |   |   |   |   |   |   |                            |   |   |   |   |   |   |   |   |   |   |                            |   |   |   |   |   |   |   |   |   |   |                            |
| 1                                 | 0   | 1                                   | 1  | 1                              | 0  | 1  | 1  | 1 | 1 | Single-tone : high 1336 Hz |  |         |                                   |  |                                     |  |  |  |  |  |  |  |    |    |    |    |    |    |    |    |  |   |   |   |   |   |   |   |   |   |   |   |   |   |   |   |   |   |   |   |   |   |   |   |   |   |   |   |   |   |   |   |   |   |   |   |   |   |   |   |   |   |   |   |   |   |   |   |   |   |   |   |   |   |   |   |   |   |   |   |   |   |   |   |   |   |   |   |   |   |   |   |   |   |   |   |   |   |   |   |   |   |   |   |   |   |   |   |   |   |   |   |   |   |   |   |   |   |   |   |   |   |   |   |   |   |   |   |   |   |   |   |   |   |   |   |   |   |   |   |   |   |   |   |   |   |   |   |   |   |   |   |   |   |   |   |   |   |   |   |   |   |   |   |   |   |   |   |   |   |   |   |   |   |   |   |   |   |   |   |   |   |   |   |   |   |   |   |   |   |   |   |   |   |   |   |    |   |   |   |   |   |   |   |   |   |   |                          |   |   |   |   |   |   |   |   |   |   |                          |   |   |   |   |   |   |   |   |   |   |                          |   |   |   |   |   |   |   |   |   |   |                          |   |   |   |   |   |   |   |   |   |   |                            |   |   |   |   |   |   |   |   |   |   |                            |   |   |   |   |   |   |   |   |   |   |                            |
| 0                                 | 0   | 1                                   | 1  | 1                              | 0  | 1  | 1  | 1 | 1 | Single-tone : high 1477 Hz |  |         |                                   |  |                                     |  |  |  |  |  |  |  |    |    |    |    |    |    |    |    |  |   |   |   |   |   |   |   |   |   |   |   |   |   |   |   |   |   |   |   |   |   |   |   |   |   |   |   |   |   |   |   |   |   |   |   |   |   |   |   |   |   |   |   |   |   |   |   |   |   |   |   |   |   |   |   |   |   |   |   |   |   |   |   |   |   |   |   |   |   |   |   |   |   |   |   |   |   |   |   |   |   |   |   |   |   |   |   |   |   |   |   |   |   |   |   |   |   |   |   |   |   |   |   |   |   |   |   |   |   |   |   |   |   |   |   |   |   |   |   |   |   |   |   |   |   |   |   |   |   |   |   |   |   |   |   |   |   |   |   |   |   |   |   |   |   |   |   |   |   |   |   |   |   |   |   |   |   |   |   |   |   |   |   |   |   |   |   |   |   |   |   |   |   |   |   |    |   |   |   |   |   |   |   |   |   |   |                          |   |   |   |   |   |   |   |   |   |   |                          |   |   |   |   |   |   |   |   |   |   |                          |   |   |   |   |   |   |   |   |   |   |                          |   |   |   |   |   |   |   |   |   |   |                            |   |   |   |   |   |   |   |   |   |   |                            |   |   |   |   |   |   |   |   |   |   |                            |

# PULSE/DTMF SWITCHABLE DIALER S-7235 Series

## DTMF Signal Frequencies

( $f_{OSC} = 3.579545 \text{ MHz}$ )

| Key-in |                 | Std. freq. | Output freq. | Error  |
|--------|-----------------|------------|--------------|--------|
| Low    | $\overline{R1}$ | 697 Hz     | 694.79 Hz    | -0.32% |
|        | $\overline{R2}$ | 770 Hz     | 771.45 Hz    | +0.19% |
|        | $\overline{R3}$ | 852 Hz     | 853.90 Hz    | +0.22% |
|        | $\overline{R4}$ | 941 Hz     | 940.01 Hz    | -0.11% |
| High   | $\overline{C1}$ | 1209 Hz    | 1209.31 Hz   | +0.03% |
|        | $\overline{C2}$ | 1336 Hz    | 1331.68 Hz   | -0.32% |
|        | $\overline{C3}$ | 1477 Hz    | 1471.85 Hz   | -0.35% |

## Application Circuit (in case of S-7235A2)

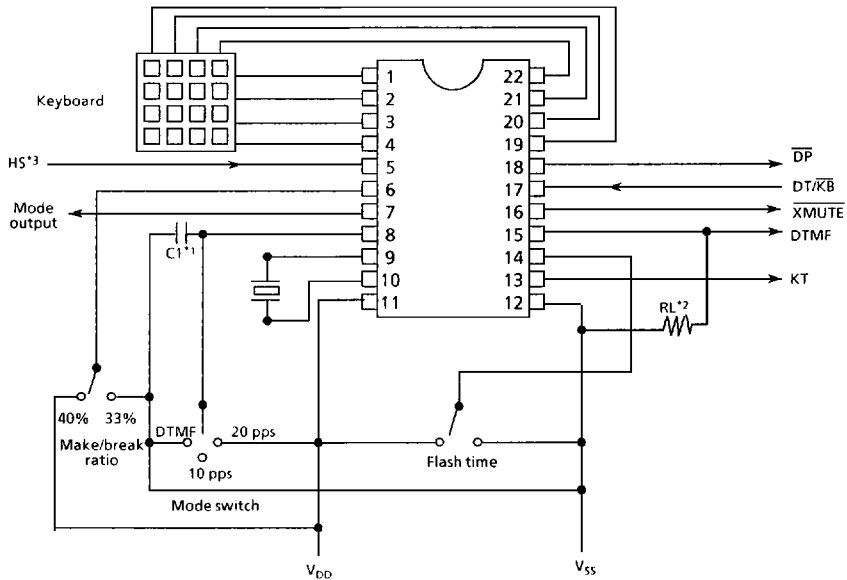

\*1  $C1 = 1000 \text{ pF}$

\*2  $5 \text{ k}\Omega \leq RL \leq 50 \text{ k}\Omega$  (10 k $\Omega$  is recommended.)

\*3  $\overline{HS}$  is set to become high (On-Hook) at power on.  $\overline{HS}$  remains high for 1 to several ms when  $V_{DD}$  is 1 V or more.

Note: When interfacing with keyboard, to improve noise characteristics, 100 pF to 600 pF of capacitor should be connected between key-input pins and GND. Also, to improve noise characteristics in mode change input, oscillating circuit parts and C1 capacitor should be connected as closely as they are on the S-7235 Series.

■ Dimensions (Unit : mm)

1. 22-pin DIP

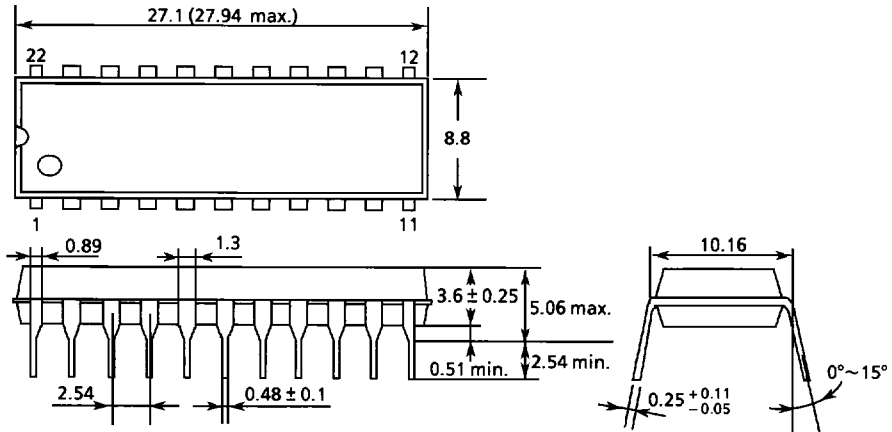

2. 24-pin SOP

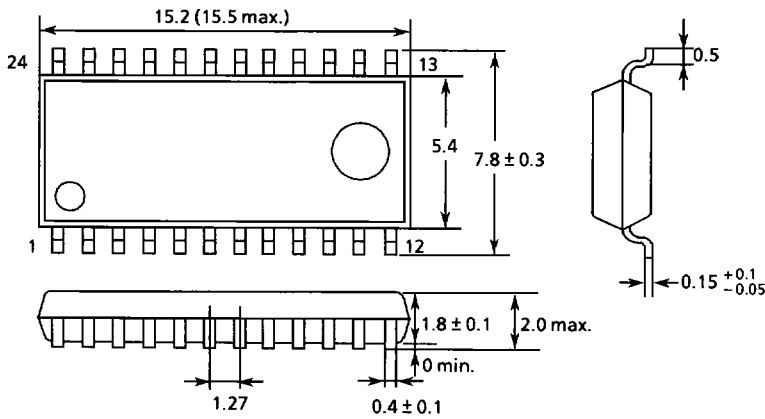

3. 18-pin DIP

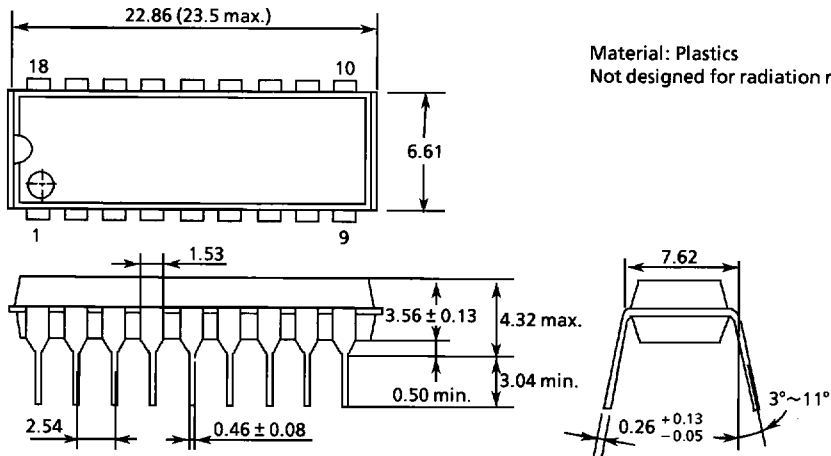

Material: Plastics  
Not designed for radiation resistant

■ Ordering Information

| Product name | Package    | Product name | Package    |
|--------------|------------|--------------|------------|
| S-7235A2     | 22-pin DIP | S-7235F2     | 22-pin DIP |
| S-7235B2     | 22-pin DIP | S-7235G2     | 22-pin DIP |
| S-7235C2     | 18-pin DIP | S-7235A2F-A  | 24-pin SOP |
| S-7235D2     | 18-pin DIP | S-7235B2F-A  | 24-pin SOP |
| S-7235E2     | 18-pin DIP | S-7235F2F-A  | 24-pin SOP |

# PULSE/DTMF SWITCHABLE DIALER

## S-7235 Series

### Absolute Maximum Ratings

( $V_{SS} = 0\text{ V}$ ,  $T_a = 25^\circ\text{C}$ )

| Parameter             | Symbol     | Conditions                | Ratings                           |
|-----------------------|------------|---------------------------|-----------------------------------|
| Power supply voltage  | $V_{DD}$   |                           | -0.3 V to +6.0 V                  |
| Input voltage         | $V_{IN}$   | Input pins                | -0.3 V to $V_{DD} + 0.3\text{ V}$ |
| Output voltage        | $V_{OUT1}$ | XMUTE, MUTE, DP, MODE OUT | -0.3 V to +12 V                   |
|                       | $V_{OUT2}$ | TONE OUT, KT              | -0.3 V to $V_{DD} + 0.3\text{ V}$ |
| Operating temperature | $T_{opr}$  |                           | -30°C to +70°C                    |
| Storage temperature   | $T_{stg}$  |                           | -40°C to +125°C                   |

### Operating Conditions

| Parameter         | Symbol    | Conditions                        | Min. | Typ.     | Max. | Unit       |
|-------------------|-----------|-----------------------------------|------|----------|------|------------|
| Operating voltage | $V_{DD1}$ | Quartz crystal used, PULSE mode*1 | 1.5  | —        | 5.5  | V          |
|                   | $V_{DD2}$ | Quartz crystal used, DTMF mode*1  | 2.0  | —        | 5.5  | V          |
|                   | $V_{DD3}$ | Ceramic used*2                    | 2.0  | —        | 5.5  | V          |
| Load resistance   | $R_L$     | Between TONE OUT and $V_{SS}$     | 5    | —        | 50   | k $\Omega$ |
| Oscillating freq. | $f_{OSC}$ |                                   | —    | 3.579545 | —    | MHz        |

\*1 Quartz crystal  $CI \leq 100\Omega$ ,  $|\Delta f| \leq 200\text{ ppm}$   $T_a = -30^\circ\text{C}$  to  $+70^\circ\text{C}$

\*2 Ceramic Murata Mfg Co., Ltd. CST 3.58 MGU 300AB ( $C_G$  and  $C_0$  are built in)

Matsushita Electronic Components Co., Ltd. EFO – FC3584A ( $C_G$  and  $C_0$  are built in)

Fujitsu Ltd. FAR-C45A-03580000-K01 ( $C_G$  and  $C_0$  are built in)

### Electrical Characteristics

#### 1. DC characteristics

(Unless otherwise specified :  $V_{DD} = 3\text{ V}$ ,  $V_{SS} = 0\text{ V}$ ,  $T_a = 25^\circ\text{C}$ )

| Parameter                     | Symbol                         | Conditions  | Min.   | Typ.  | Max.                | Unit          |               |
|-------------------------------|--------------------------------|---|--|-------|---------------------|---------------|---------------|
| Operating current consumption | $I_{DD1}$                      | PULSE mode $\overline{HS} = V_{SS}$   | $V_{DD} = 3.0\text{ V}$                                      | —     | —                   | 0.5           | mA            |
|                               | $I_{DD2}$                      | Output open   | $V_{DD} = 5.5\text{ V}$                                      | —     | —                   | 2.0           | mA            |
|                               | $I_{DD3}$                      | DTMF mode $\overline{HS} = V_{SS}$  | $V_{DD} = 3.0\text{ V}$                                      | —     | —                   | 1.0           | mA            |
|                               | $I_{DD4}$                      | Output open   | $V_{DD} = 5.5\text{ V}$                                      | —     | —                   | 4.0           | mA            |
| Standby current               | $I_{SD1}$                      | $\overline{HS} = V_{DD}$  | $V_{DD} = 3.0\text{ V}$                                      | —     | —                   | 0.1           | $\mu\text{A}$ |
|                               | $I_{SD2}$                      |   | $V_{DD} = 5.5\text{ V}$                                      | —     | —                   | 10            | $\mu\text{A}$ |
| Data retention voltage        | $V_{DR}$                       |   | 1.0  | —     | 5.5                 | V             |               |
| Input voltage                 | $V_{IH}$                       | $V_{DD} = 1.5$ to $5.5\text{ V}$  | $0.8 \times V_{DD}$  | —     | $V_{DD}$            | V             |               |
|                               | $V_{IL}$                       |   | 0  | —     | $0.2 \times V_{DD}$ | V             |               |
| Input current                 | $I_{IH1}$                      | $\overline{C1}$ to $\overline{C4}$  | Key I/O = low $V_{IH} = 0.5\text{ V}$                        | 75    | —                   | —             | $\mu\text{A}$ |
|                               | $I_{IL1}$                      | R1 to R4  | Key I/O = high $V_{IL} = V_{SS}$                             | -75   | -30                 | -12           | $\mu\text{A}$ |
|                               | $I_{IH2}$                      | MODE IN   | Low level: $V_{IH} = V_{DD}$                                 | 10    | 30                  | 90            | $\mu\text{A}$ |
|                               | $I_{IL2}$                      |   | High level: $V_{IL} = 0\text{ V}$                            | -90   | -30                 | -10           | $\mu\text{A}$ |
| Input leakage current         | $I_{ILK}$                      | $\overline{HS}$ , M/B, FTS A, FTS B, DT/KB<br>$V_{IN} = V_{DD}$ or $0\text{ V}$ , $V_{DD} = 5.5\text{ V}$                                       | -2.0   | 0.0   | 2.0                 | $\mu\text{A}$ |               |
|                               |                                | $\overline{C1}$ to $\overline{C4}$ , R1 to R4, MODE IN, $\overline{HS} = V_{DD}$<br>$V_{IN} = V_{DD}$ or $0\text{ V}$ , $V_{DD} = 5.5\text{ V}$ | -2.0   | 0.0   | 2.0                 | $\mu\text{A}$ |               |
| Output current                | $I_{OH1}$                      | KT  | $V_{OH} = 2.5\text{ V}$                                      | —     | —                   | -0.5          | mA            |
|                               | $I_{OL1}$                      |   | $V_{OL} = 0.5\text{ V}$                                      | 0.5   | —                   | —             | mA            |
|                               | $I_{OL2}$                      | DP, XMUTE, MUTE, MODE OUT<br>$V_{OL} = 0.5\text{ V}$  | 1.4  | 4.0   | —                   | mA            |               |
| Output off-leakage current    | $I_{OLK1}$                     | KT, DP, XMUTE, MUTE, MODE OUT<br>$V_{OUT} = V_{DD}$ or $0\text{ V}$ , $V_{DD} = 5.5\text{ V}$   | -2.0   | 0.0   | 2.0                 | $\mu\text{A}$ |               |
| DTMF                          | Off-leakage current            | $I_{OLK2}$  | $V_{OUT} = V_{DD}$ or $0\text{ V}$ , $V_{DD} = 5.5\text{ V}$ | -2.0  | 0.0                 | 2.0           | $\mu\text{A}$ |
|                               | Row tone output                | $V_{TR}$  | $V_{DD} = 5.5\text{ V}$                                      | -14.3 | —                   | -10.5         | dBm*          |
|                               | Column – Row tone pre-emphasis | C/R   |  | 2.0   | 2.5                 | 3.0           | dB            |
|                               | Harmonic distortion            | % DIS   | $R_L = 10\text{ k}\Omega$                                    | —     | 2                   | 10            | %             |
| Oscillation startup time      | $t_{OSC}$                      |   | —  | 2     | —                   | ms            |               |

2. AC characteristics

| Parameter                                 |                                  | Symbol                             | Conditions                         | Min.        | Typ.  | Max.  | Unit |    |
|---|----------------------------------|------------------------------------|------------------------------------|-------------|-------|-------|------|----|
| P<br>U<br>L<br>S<br>E<br>m<br>o<br>d<br>e | Make-break ratio                 | M/B                                | M/B = V <sub>DD</sub> (40%)        | —           | 40.0  | —     | %    |    |
|   |                                  |                                    | M/B = V <sub>SS</sub> (33%)        | —           | 33.3  | —     | %    |    |
|   | Dial rate                        | DR                                 | MODE IN = open (10 pps)            | —           | 9.86  | —     | pps  |    |
|   |                                  |                                    | MODE IN = V <sub>DD</sub> (20 pps) | —           | 19.73 | —     | pps  |    |
|   | Pre-digital pause                | t <sub>PDP</sub>                   | 10 pps                             | 33%         | —     | 33.79 | —    | ms |
|   |                                  |                                    |                                    | 40%         | —     | 40.55 | —    | ms |
|   |                                  |                                    | 20 pps                             | 33%         | —     | 16.90 | —    | ms |
|   |                                  |                                    |                                    | 40%         | —     | 20.28 | —    | ms |
|   | Make time                        | t <sub>M</sub>                     | 10 pps                             | 33%         | —     | 33.79 | —    | ms |
|   |                                  |                                    |                                    | 40%         | —     | 40.55 | —    | ms |
|   |                                  |                                    | 20 pps                             | 33%         | —     | 16.90 | —    | ms |
|   |                                  |                                    |                                    | 40%         | —     | 20.28 | —    | ms |
|   | Break time                       | t <sub>B</sub>                     | 10 pps                             | 33%         | —     | 67.58 | —    | ms |
|   |                                  |                                    |                                    | 40%         | —     | 60.83 | —    | ms |
|   |                                  |                                    | 20 pps                             | 33%         | —     | 33.79 | —    | ms |
|   |                                  |                                    |                                    | 40%         | —     | 30.41 | —    | ms |
| Inter-digital pause time                  | t <sub>IDP</sub>                 | A2 to C2 type<br>10 pps            | 33%                                | —           | 658.9 | —     | ms   |    |
|   |                                  |                                    | 40%                                | —           | 838.0 | —     | ms   |    |
|   |                                  | A2 to C2 type<br>20 pps            | 33%                                | —           | 469.7 | —     | ms   |    |
|   |                                  |                                    | 40%                                | —           | 473.1 | —     | ms   |    |
|   |                                  | D2 to G2 type<br>10 pps            | 33%                                | —           | 831.3 | —     | ms   |    |
|   |                                  |                                    | 40%                                | —           | 838.0 | —     | ms   |    |
|   |                                  | D2 to G2 type<br>20 pps            | 33%                                | —           | 469.7 | —     | ms   |    |
|   |                                  |                                    | 40%                                | —           | 473.1 | —     | ms   |    |
| XMUTE, MUTE<br>overlap time               | t <sub>MOP1</sub>                | 10 pps                             | 33%                                | —           | 621.8 | —     | ms   |    |
|   |                                  |                                    | 40%                                | —           | 794.1 | —     | ms   |    |
|   |                                  | 20 pps                             | 33%                                | —           | 449.4 | —     | ms   |    |
|   |                                  |                                    | 40%                                | —           | 449.4 | —     | ms   |    |
|   | t <sub>MOP2</sub>                |                                    |                                    | —           | 449.4 | —     | ms   |    |
| D<br>T<br>M<br>F<br>m<br>o<br>d<br>e      | Tone output pre-digital<br>pause | t <sub>TPP</sub>                   |                                    | —           | 3.38  | —     | ms   |    |
|   |                                  |                                    |                                    |             |       |       |      |    |
|   | Tone duration                    | t <sub>MF</sub>                    | A2, F2 type                        | —           | 70.9  | —     | ms   |    |
|   |                                  |                                    | B2, C2, D2, E2, G2 type            | —           | 84.5  | —     | ms   |    |
|   | Tone inter-pause time            | t <sub>TIP</sub>                   | A2, F2 type                        | —           | 81.1  | —     | ms   |    |
|   |                                  |                                    | B2, C2, D2, E2, G2 type            | —           | 87.9  | —     | ms   |    |
|   | Tone output off delay time       | t <sub>MFD</sub>                   |                                    | —           | 24.0  | —     | ms   |    |
|   | XMUTE overlap time               | t <sub>MOT1</sub>                  | t <sub>TIP</sub> = 81.1 ms         | —           | 74.3  | —     | ms   |    |
| t <sub>TIP</sub> = 87.9 ms                |                                  |                                    | —                                  | 81.1        | —     | ms    |      |    |
| t <sub>MOT1</sub>                         |                                  |                                    | —                                  | 3.38        | —     | ms    |      |    |
|   |                                  | T is accessed                      | —                                  | 6.76        | —     | ms    |      |    |
| Tone output period                        | t <sub>T</sub>                   | t <sub>MF</sub> + t <sub>TIP</sub> | A2, F2 type                        | —           | 152.0 | —     | ms   |    |
|   |                                  |                                    | B2, C2, D2, E2, G2<br>type         | —           | 172.4 | —     | ms   |    |
| Auto-<br>pause                            | Timer pause                      | t <sub>AP</sub>                    | A2, D2, E2, F2, G2 type            | —           | 3.6   | —     | s    |    |
|   |                                  |                                    | B2, C2 type                        | —           | 2.0   | —     | s    |    |
| F<br>l<br>a<br>s<br>h                     | Flash time                       | t <sub>FL</sub>                    | A2 type                            | FTSA = high | —     | 608.0 | —    | ms |
|   |                                  |                                    |                                    | FTSA = low  | —     | 203.0 | —    | ms |
|   |                                  |                                    | B2 type                            | FTSB = high | —     | 933.0 | —    | ms |
|   |                                  |                                    |                                    | FTSB = low  | —     | 94.6  | —    | ms |
|   |                                  | C2 type                            | —                                  | 933.0       | —     | ms    |      |    |
|   |                                  | D2 type                            | —                                  | 94.6        | —     | ms    |      |    |
|   |                                  | E2, G2 type                        | —                                  | 608.0       | —     | ms    |      |    |
|   |                                  | F2 type                            | FTSA = high                        | —           | 635.4 | —     | ms   |    |
| FTSA = low                                | —                                |                                    | 94.6                               | —           | ms    |       |      |    |
| Flash-pause time                          | t <sub>FLP</sub>                 |                                    | —                                  | 1.0         | —     | s     |      |    |

**PULSE/DTMF SWITCHABLE DIALER**  
**S-7235 Series**

| Parameter         |                                 | Symbol                 | Conditions         | Min. | Typ.        | Max. | Unit |
|-------------------|---------------------------------|------------------------|--------------------|------|-------------|------|------|
| Key<br>in         | Valid key input                 | $t_{KIN}$              | While oscillating  | 25.0 | —           | —    | ms   |
|                   | Pause-time btwn valid keys      | $t_{KIP}$              |                    | 25.0 | —           | —    | ms   |
|                   | Chattering free time            | $t_{CH}$               | Key-on and key-off | —    | 16.9        | —    | ms   |
|                   | Key scan frequency              | $f_{KS}$               | C1 to C4, R1 to R4 | —    | 296         | —    | Hz   |
| Key<br>in<br>tone | Key-in-tone output time         | $t_{KT}$               |                    | —    | 37.2        | —    | ms   |
|                   | Key-in-tone frequency           | $f_{KT}$               |                    | —    | 1776        | —    | Hz   |
|                   | Key-in-tone output delay time   | $t_{MKT}$              |                    | —    | 6.76        | —    | ms   |
|                   | Key-in-tone output startup time | $t_{KTS}$              |                    | —    | 36.0        | —    | ms   |
| XMUTE<br>MUTE     | XMUTE, MUTE output startup time | $t_{KMS}$              |                    | —    | 30.0        | —    | ms   |
| MODE<br>IN        | MODE IN scan frequency          | $f_{MIN}$              |                    | —    | 148.0       | —    | Hz   |
| MODE<br>OUT       | MODE OUT blink                  | $t_{MFL}$              |                    | —    | 432.0       | —    | ms   |
|                   | MODE OUT output startup time    | $t_{MO1}$<br>$t_{MO2}$ |                    | —    | 24.0<br>1.9 | —    | ms   |

■ **Timing Charts** (Dotted lines mean high-impedance)

1. Normal dialing

1.1 PULSE mode in redialing

(MODE IN = high or open, MODE OUT = TONE OUT = high impedance)

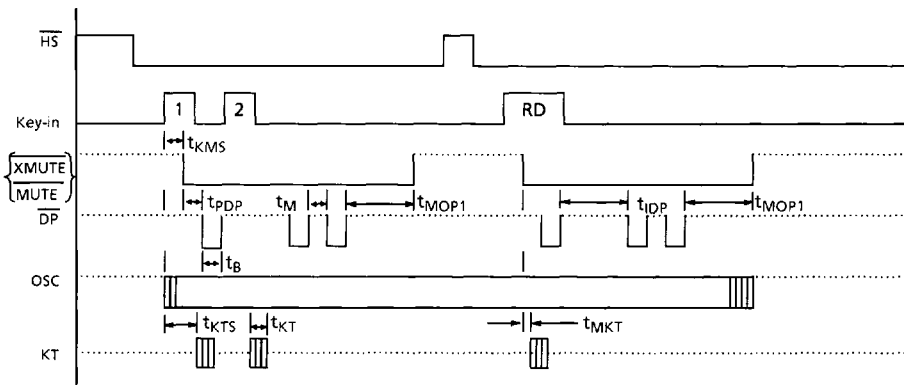

1.2 DTMF mode in redialing

(MODE IN = low,  $\overline{\text{MUTE}} = \overline{\text{DP}} =$  high impedance)

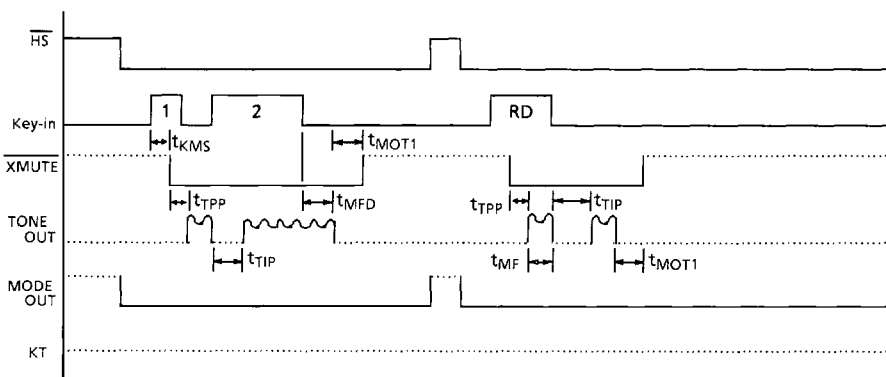

2. Auto-pause

2.1 PULSE mode in normal dialing

(MODE IN = high or open, MODE OUT = TONE OUT = high impedance)

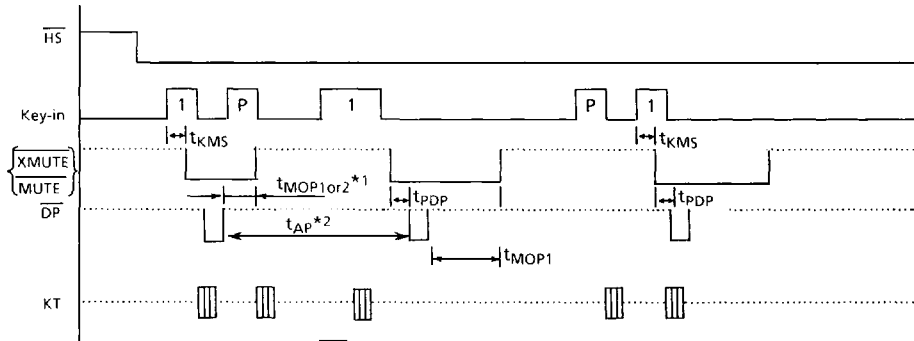

\*1 When **P** is input during  $\overline{DP}$  dialing,  $t_{MOP2}$  is selected. Otherwise  $t_{MOP1}$ .

\*2 When **P** is input between  $t_{MOP1}$ s, a period from  $\overline{DP}$  output to the next  $\overline{DP}$  output is  $t_{MOP1} + t_{AP}$ .

2.2 DTMF mode in normal dialing

(MODE IN = low,  $\overline{MUTE} = \overline{DP} =$  high impedance)

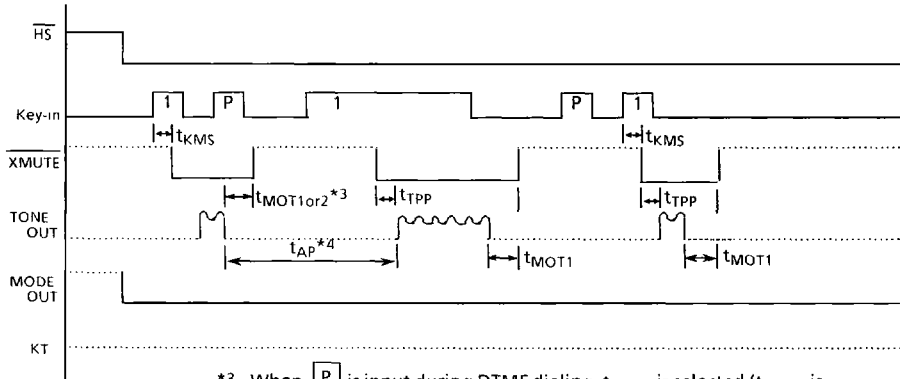

\*3 When **P** is input during DTMF dialing,  $t_{MOT2}$  is selected ( $t_{MOT2}$  is 3.38ms.). Otherwise  $t_{MOT1}$ .

\*4 When **P** is input between  $t_{MOT1}$ s, a period from DTMF signal output to the next DTMF signal output is  $t_{MOT1} + t_{AP}$ .

**PULSE/DTMF SWITCHABLE DIALER**  
**S-7235 Series**

3. Mixed dialing

3.1 Mode change by **T** (MODE IN = high or open)

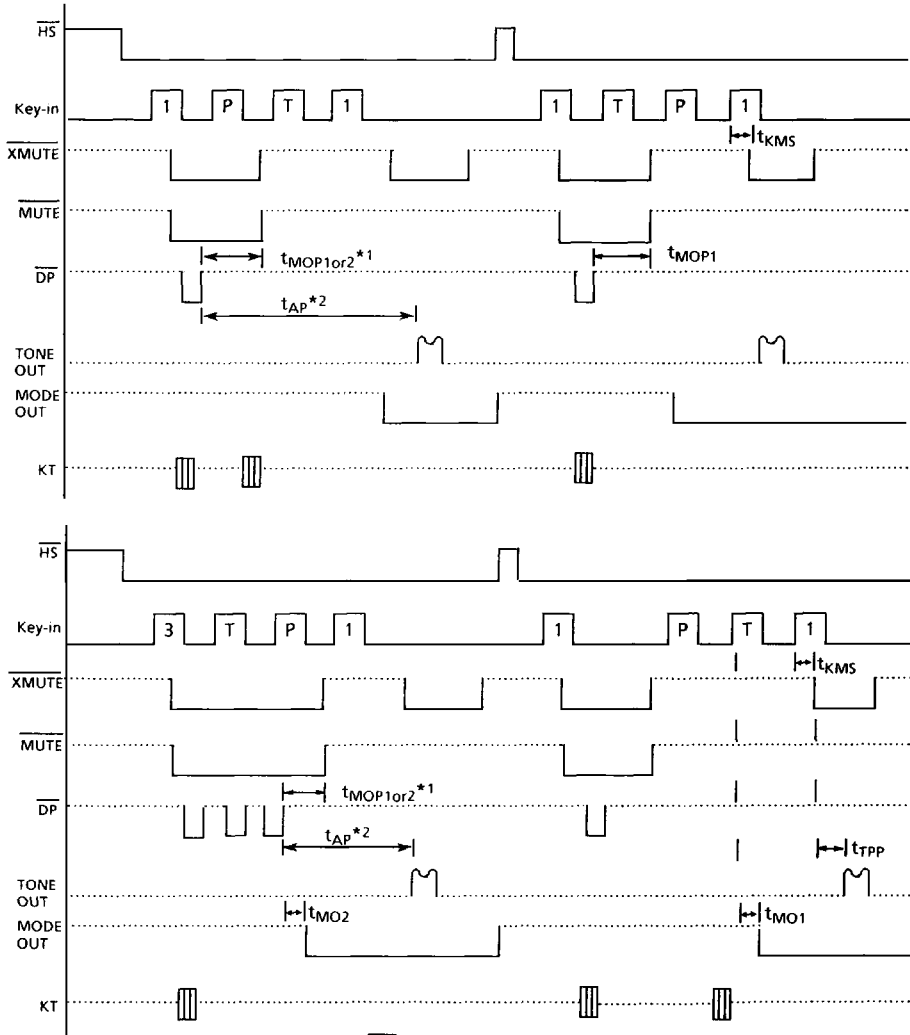

- \*1 When **P** is input during  $\overline{DP}$  dialing,  $t_{MO2}$  is selected. Otherwise  $t_{MO1}$ .
- \*2 When **P** is input between  $t_{MOP1}$ s, a period from  $\overline{DP}$  output to TONE OUT output is  $t_{MOP1} + t_{AP}$ .

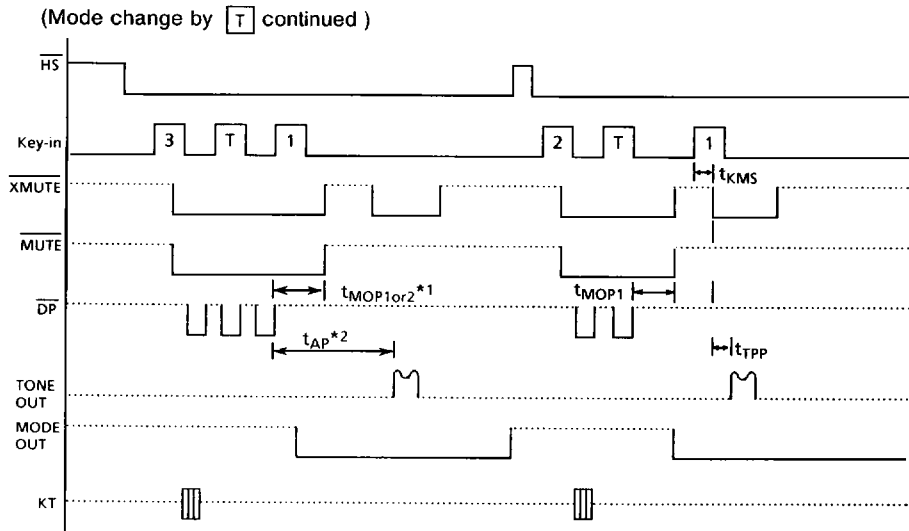

### 3.2 Mode change by MODE IN

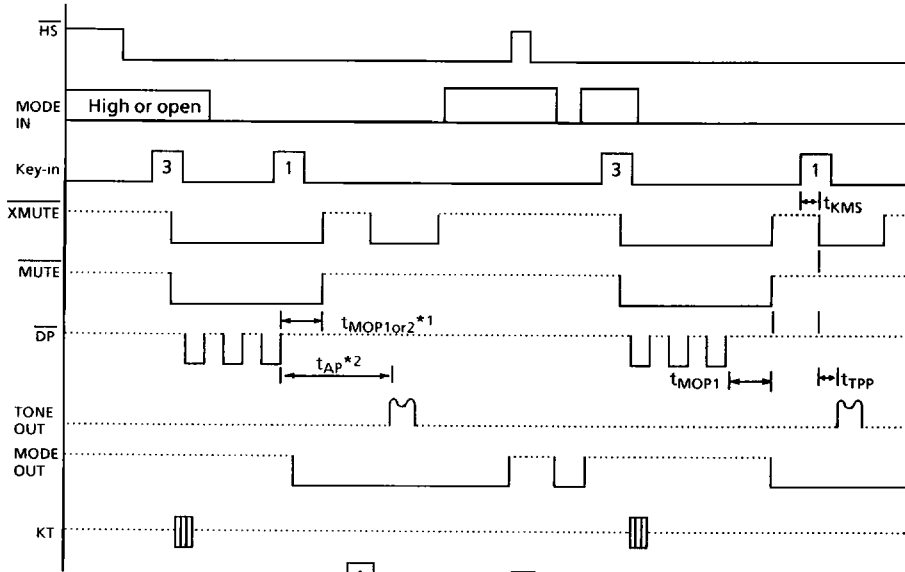

- \*1 When **1** is input during  $\overline{DP}$  dialing,  $t_{MOP2}$  is selected. Otherwise  $t_{MOP1}$ .
- \*2 When **1** is input between  $t_{MOP1}$ , a period from  $\overline{DP}$  output to TONE OUT output is  $t_{MOP1} + t_{AP}$ .

**PULSE/DTMF SWITCHABLE DIALER**  
**S-7235 Series**

4. Flash

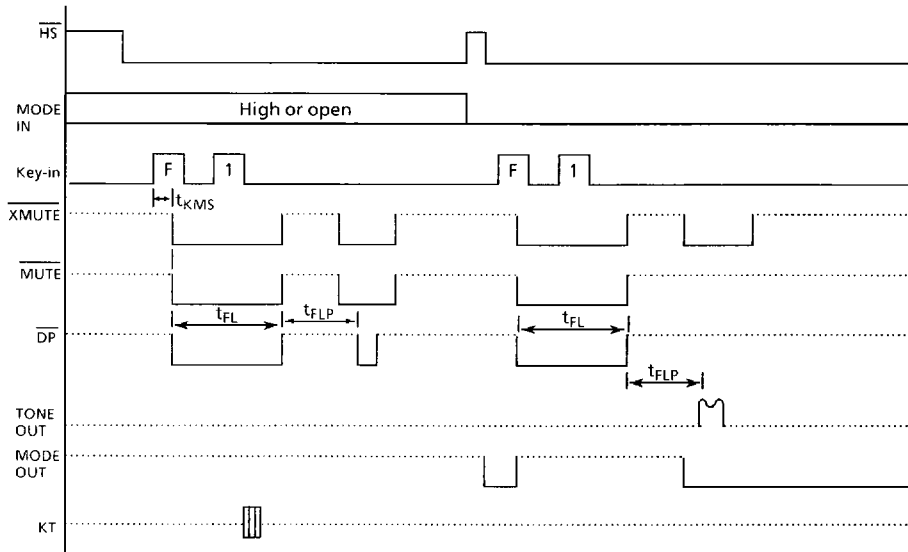

5. Auto-pause release

5.1 PULSE mode

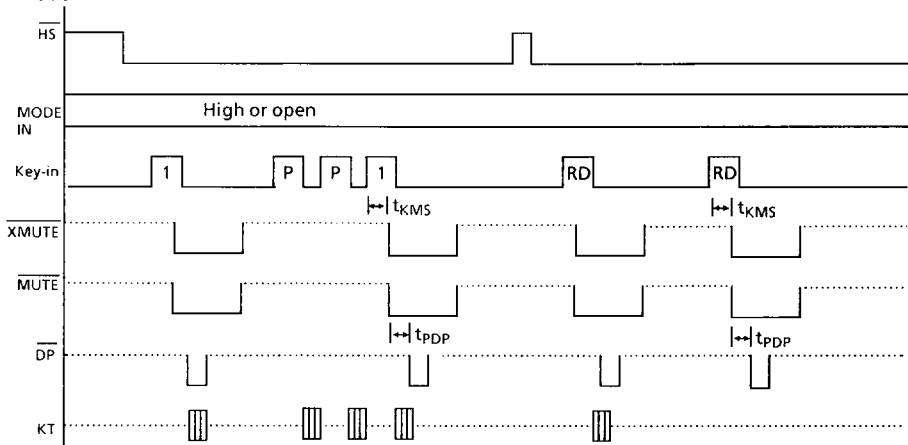

5.2 DTMF mode

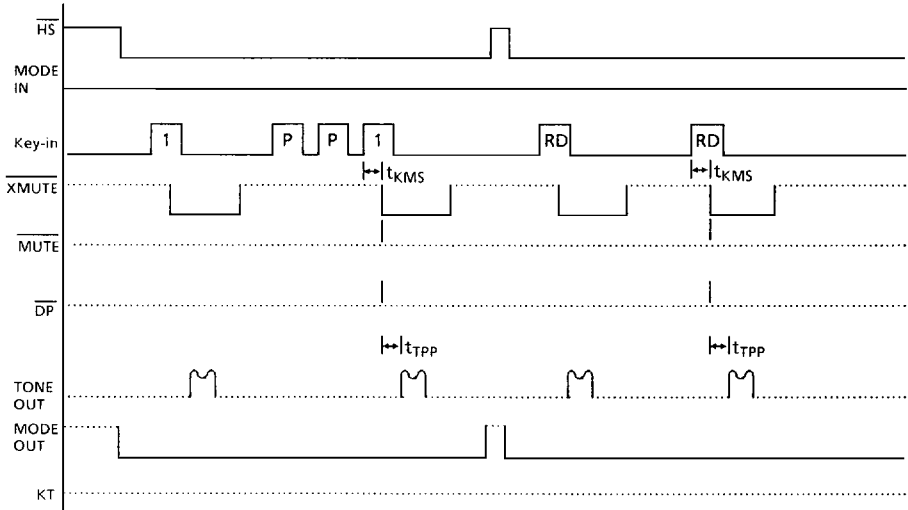

6. Wait-pause release

6.1 Mixed redialing

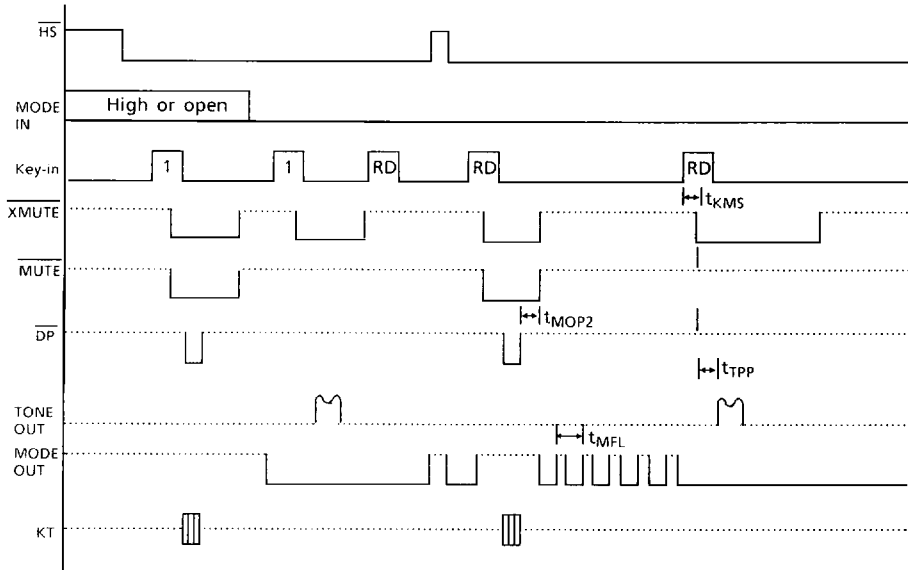

6.2 DTMF redialing

