

FEATURES

- SURFACE MOUNT IN SIZES 0102 (0805), 0204 (1406) AND 0207 (2410)
- HIGH RELIABILITY AEC-Q200 QUALIFIED (see part numbering system for details)
- HIGH HUMIDITY 56-DAY 85°C/85% RH AVAILABLE (contact NIC for available sizes and values, see part number system for how to order)
- THIN FILM CONSTRUCTION
- AVAILABLE IN PRECISION TOLERANCE AND TC (TO ±0.1% TOL. AND ±10PPM TC)
- ALL SIZES ARE AVAILABLE IN TAPE/REEL FOR AUTOMATIC MOUNTING
- SAC REFLOW SOLDERABLE (+260°C FOR 10 SECONDS)
- AVAILABLE IN ZERO OHM JUMPER

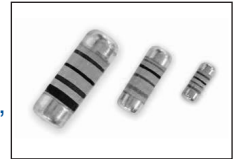

[See Pages 12 ~ 17 for Legacy Part Numbers]

STANDARD POWER SPECIFICATIONS

Type	Size	Power Rating at 70°C	Max. *1 Working Voltage	Max. *2 Overload Voltage	Resistance Tolerance Code	Temperature Coefficient (ppm/°C)	Resistance Range (Ω)*3	Resistance Values	Operating Temperature Range
NFR0102W	0102 (0805)	0.125W	150V	300V	±0.1% (B) ±0.25% (C) ±0.5% (D) ±1% (F)	±15 (N)	100 ~ 56K	E-24 & E-96	-55°C ~ +155°C
					±0.1% (B) ±0.25% (C) ±0.5% (D) ±1% (F)	±25 (C)	100 ~ 82K		
					±0.5% (D) ±1% (F)		49.9 ~ 200K		
					±0.5% (D) ±1% (F)	49.9 ~ 390K			
					±0.5 (D) ±1% (F)	±50 (D)	8.2 ~ 1M	E-24	
					±5% (J)		40.2 ~ 1M	E-24 & E-96	
					±1% (F) ±5% (J)	±100 (E)	E-24		
NFR0204V	0204 (1406)	0.25W	200V	400V	±0.1% (B) ±0.25% (C)	±5 (S)	10 ~ 332K	E-24 & E-96	-55°C ~ +155°C
					±0.1% (B) ±0.25% (C) ±0.5% (D) ±1% (F)	±10 (B)	49.9 ~ 20K		
					±0.1% (B) ±0.25% (C) ±0.5% (D) ±1% (F)		±15 (N)	10 ~ 300K	
					±0.1% (B) ±0.25% (C)	±25 (C)		10 ~ 1M	
					±0.25% (C) ±0.5% (D) ±1% (F)		10 ~ 3.9M		
					±0.5% (D) ±1% (F)		1.0 ~ 3.9M		
					±0.1% (B) ±0.25% (C) ±0.5% (D) ±1% (F)	±50 (D)	10 ~ 1M	E-24	
					±0.25% (C) ±0.5% (D) ±1% (F)		1.0 ~ 1M		
					±1% (F) ±5% (J)		0.2 ~ 3.9M		
					±5% (J)	±100 (E)	0.2 ~ 3.9M	E-24	
					±1% (F) ±5% (J)		0.1 ~ 1M	E-24 & E-96	
					±1% (F) ±5% (J)	0.1 ~ 1M	E-24		

Continued Next Page

Meets Applicable Requirements of IEC 60115-1, IEC 60068

DIMENSIONS (mm)

Type	Size	L	D	C
NFR0102	0102	2.2 ± 0.1	1.10 ± 0.10	0.4 min.
NFR0204	0204	3.5 ± 0.2	1.40 ± 0.15	0.5 min.
NFR0207	0207	5.9 ± 0.2	2.20 ± 0.20	0.5 min.

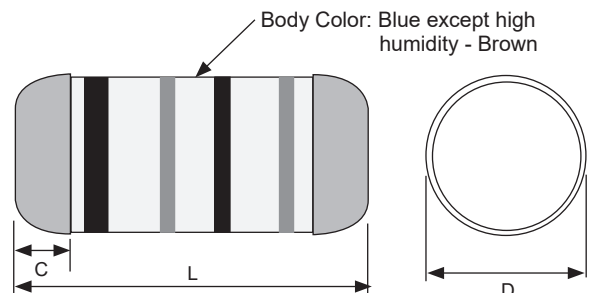

STANDARD POWER SPECIFICATIONS

Type	Size	Power Rating at 70°C	Max. *1 Working Voltage	Max. *2 Overload Voltage	Resistance Tolerance Code	Temperature Coefficient (ppm/°C)	Resistance Range (Ω)*3	Resistance Values	Operating Temperature Range	
NFR0207U	0207 (2410)	0.50W	300V	600V	±0.1% (B) ±0.25% (C)	±5 (S)	10 ~ 332K	E-24 & E-96	-55°C ~ +125°C	
					±0.1% (B) ±0.25% (C) ±0.5% (D) ±1% (F)	±10 (B)	49.9 ~ 20K	E-24 & E-96	-55°C ~ +155°C	
					±0.1% (B) ±0.25% (C) ±0.5% (D) ±1% (F)	±15 (N)	10 ~ 300K			
					±0.1% (B) ±0.25% (C) ±0.5% (D) ±1% (F)	±25 (C)	10 ~ 1M			
					±0.5% (D)		10 ~ 3.9M			
					±1% (F)		1.0 ~ 3.9M			
					±0.1% (B) ±0.25% (C) ±0.5% (D) ±1% (F)	±50 (D)	10 ~ 1M			
					±0.25% (C)		1.0 ~ 1M			
					±0.5% (D)		1.0 ~ 3.9M			
					±1% (F)		0.2 ~ 3.9M			
					±5% (J)	±100 (E)	0.2 ~ 3.9M			E-24
					±1% (F)		0.1 ~ 1M			E-24 & E-96
					±5% (J)		0.1 ~ 1M			E-24

HIGH POWER SPECIFICATIONS

Type	Size	Power Rating at 70°C	Max. *1 Working Voltage	Max. *2 Overload Voltage	Resistance Tolerance Code	Temperature Coefficient (ppm/°C)	Resistance Range (Ω)*3	Resistance Values	Operating Temperature Range	
NFR0102P	0102 (0805)	0.20W	200V	400V	±0.1% (B) ±0.25% (C) ±0.5% (D) ±1% (F)	±15 (N)	100 ~ 56K	E-24 & E-96	-55°C ~ +155°C	
					±0.1% (B) ±0.25% (C) ±0.5% (D) ±1% (F)	±25 (C)	100 ~ 82K			
					±0.5% (D)		49.9 ~ 200K			
					±1% (F)		49.9 ~ 390K			
					±0.5 (D) ±1% (F)	±50 (D)	8.2 ~ 1M	E-24		
					±5% (J)		±100 (E)	40.2 ~ 1M		E-24 & E-96
					±1% (F)	±100 (E)		40.2 ~ 1M		E-24
±5% (J)	±100 (E)	40.2 ~ 1M	E-24							
NFR0204G		0204 (1406)	0.40W	200V	400V	±0.1% (B) ±0.25% (C)	±5 (S)	10 ~ 332K	E-24 & E-96	-55°C ~ +125°C
	±0.1% (B) ±0.25% (C) ±0.5% (D) ±1% (F)					±15 (N)	10 ~ 300K	E-24 & E-96	-55°C ~ +155°C	
	±0.1% (B) ±0.25% (C) ±0.5% (D) ±1% (F)					±25 (C)	10 ~ 1.0M			
	±0.5% (D)						10 ~ 3.9M			
	±1% (F)						1.0 ~ 3.9M			
	±5% (J)					±50 (D)	10 ~ 1.0M			E-24 & E-96
	±0.1% (B) ±0.25% (C)						1.0 ~ 1.0M			
	±0.5 (D)						1.0 ~ 3.9M			
	±1% (F)						0.2 ~ 3.9M			
	±5% (J)					±100 (E)	0.2 ~ 3.9M			E-24
	±1% (F)						0.1 ~ 1.0M			E-24 & E-96
	±5% (J)						0.1 ~ 1.0M			E-24

Continued Next Page

HIGH POWER SPECIFICATIONS

Type	Size	Power Rating at 70°C	Max. *1 Working Voltage	Max. *2 Overload Voltage	Resistance Tolerance Code	Temperature Coefficient (ppm/°C)	Resistance Range (Ω)*3	Resistance Values	Operating Temperature Range
NFR0207T	0207 (2410)	1.0W	350V	700V	±0.1% (B) ±0.25% (C)	±5 (S)	10 ~ 332K	E-24 & E-96	-55°C ~ +125°C
					±0.1% (B) ±0.25% (C) ±0.5% (D) ±1% (F)	±15 (N)	10 ~ 300K	E-24 & E-96	-55°C ~ +155°C
					±0.1% (B) ±0.25% (C) ±0.5% (D) ±1% (F) ±5% (J)	±25 (C)	10 ~ 1.0M	E-24 & E-96	
							10 ~ 3.9M		
					±0.1% (B) ±0.25% (C) ±0.5% (D) ±1% (F) ±5% (J)	±50 (D)	10 ~ 1.0M	E-24 & E-96	
							1.0 ~ 1.0M		
					±0.1% (B) ±0.25% (C) ±0.5% (D) ±1% (F) ±5% (J)	±100 (E)	1.0 ~ 3.9M	E-24 & E-96	
							0.2 ~ 3.9M		
					±0.1% (B) ±0.25% (C) ±0.5% (D) ±1% (F) ±5% (J)	±100 (E)	0.1 ~ 1.0M	E-24 & E-96	
							E-24		

ZERO OHM JUMPER SPECIFICATIONS

Type	Size	Maximum Current	Maximum Resistance	Operating Temperature Range
NFR0102ZOTRQYF	0102	Max. current 2A	Max. resistance 15mΩ	-55°C ~ +155°C
NFR0204ZOTRQYF	0204	Max. current 2A	Max. resistance 15mΩ	
NFR0207ZOTRQYF	0207	Max. current 4A	Max. resistance 15mΩ	

PART NUMBER SYSTEM (0.1%, 0.25%, 0.5%, 1% TOLERANCE E-24 & E-96 VALUES)

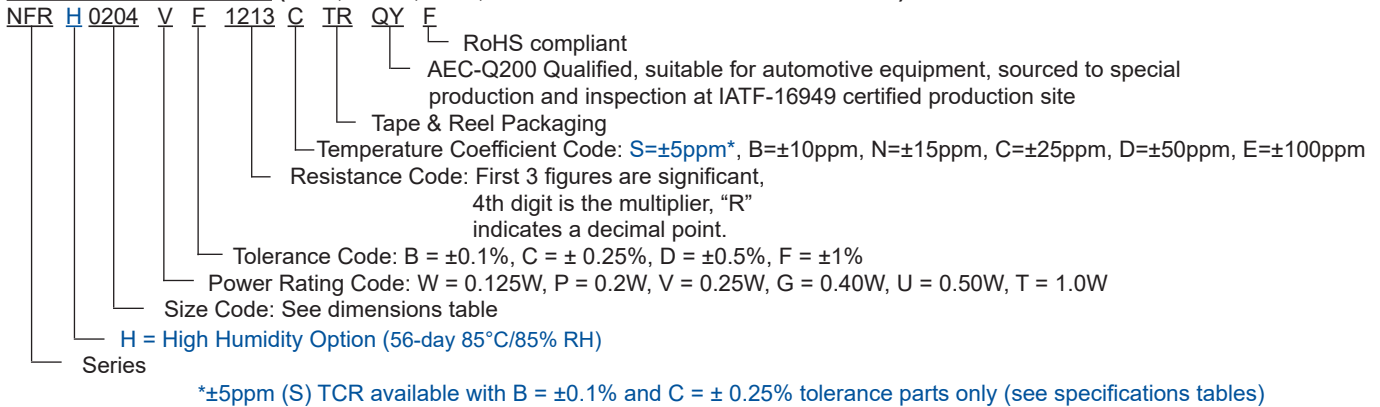

PART NUMBER SYSTEM (5% E-24 VALUES)

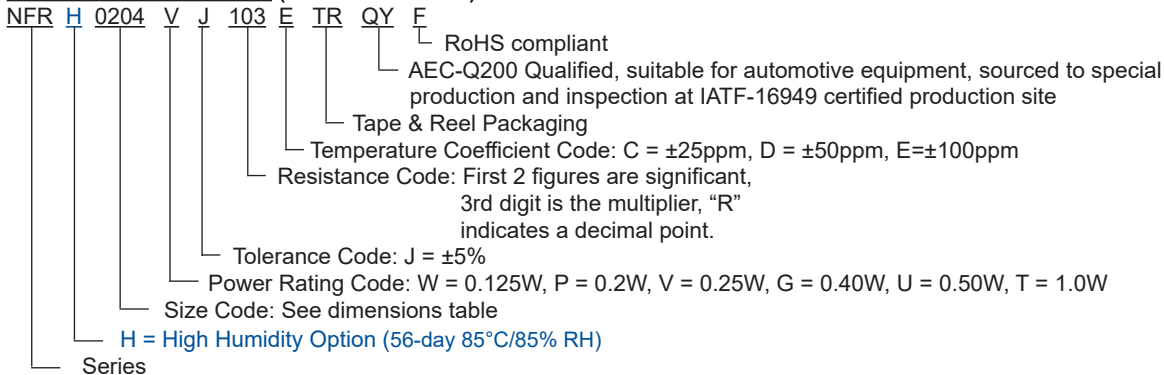

ENVIRONMENTAL CHARACTERISTICS [AEC-Q200 QYF Part Numbers]

Item	Specification	Test Method
Temperature Coefficient of Resistance (TCR)	As specified	JIS-C-5201-1 4.8 IEC-60115-1 4.8 -55°C ~ +125°C, +25 is reference temperature
Short Time Overload	10Ω~ 270KΩ ±(0.1%+0.05Ω) <10Ω & >270KΩ ±(0.15%+0.05Ω) 0102: ±(0.15%+0.05Ω)	JIS-C-5201-1 4.13 IEC-60115-1 4.13 RCWV*2.5 or Max. Overload Voltage whichever is less for 5 seconds
Insulation Resistance	≥10GΩ	JIS-C-5201-1 4.6 IEC-60115-1 4.6 Max. Overload Voltage for 1 minute
Endurance	10Ω~ 270KΩ ±(0.25%+0.05Ω) <10Ω & >270KΩ ±(0.5%+0.05Ω) 0102: ±(0.5%+0.05Ω)	JIS-C-5201-1 4.25 IEC-60115-1 4.25.1 MIL-STD-202 Method 108 +70°C±2°C, RCWV for 1000 hrs with 1.5 hrs "ON" and 0.5 hrs "OFF"
Bias Humidity	10Ω~ 270KΩ ±(0.5%+0.05Ω) <10Ω & >270KΩ ±(1%+0.05Ω) 0102: ±(2%+0.05Ω)	Mil-Std-202 Method103 1000 hrs 85°C/85%RH with 10% rated power Optional "H" parts 56 days (1344 hrs) 85°C/85%RH with 10% rated power
High Temperature Exposure	10Ω~ 270KΩ ±(0.25%+0.05Ω) <10Ω & >270KΩ ±(1%+0.05Ω) 0102: ±(1%+0.05Ω)	Mil-Std-202 Method108 at +155°C for 1000 hours
Board Flex	10Ω~ 270KΩ ±(0.1%+0.05Ω) <10Ω & >270KΩ ±(0.5%+0.05Ω) 0102: ±(0.5%+0.05Ω)	AEC-Q200-005 Bend once for 60 seconds 2mm
Solderability	95% minimum coverage	JIS-C-5201-1 4.17 IEC-60115-1 4.17 J-STD-002 +245°C±5°C for 3 seconds
Resistance to Soldering Heat	10Ω~ 270KΩ ±(0.1%+0.05Ω) <10Ω & >270KΩ ±(0.25%+0.05Ω) 0102: ±(0.25%+0.05Ω)	Mil-Std-202 Method210 +260°C for 10 seconds
Voltage Proof	No breakdown or flashover	JIS-C-5201-1 4.7 IEC-60115-1 4.7 1.42 times Max. Operating Voltage for 1 minute
Leaching	individual leaching area ≤5% Total leaching area ≤10%	JIS-C-5201-1 4.18 IEC-60068-2-58 8.2.1 +260°C±5°C for 30 seconds
Temperature Cycling	10Ω~ 270KΩ ±(0.25%+0.05Ω) <10Ω & >270KΩ ±(0.5%+0.05Ω) 0102: ±(1%+0.05Ω)	JESD22 Method JA-104 -55°C ~ +125°C, 1000 cycles
Mechanical Shock	±(0.25%+0.05Ω)	Mil-Std-202 Method 213 Wave Form: Tolerance for half sine shock pulse. Peak value is 100g's. Normal duration (D) is 6.
Vibration	±(0.5%+0.05Ω)	Mil-Std-202 Method 204 5g's for 20 minutes, 12 cycles each of 3 orientations, 10 ~ 2000Hz
ESD	±(0.5%+0.05Ω)	AEC-Q200-002 Human body, 2KV
Resistance to Solvents	No visible damage on appearance and marking.	Mil-Std-202 Method 215 Add Aqueous wash chemical - OKEM Clean or equivalent. Do not use banned solvents
Terminal Strength	No broken	AEC-Q200-006 Force of 1.8kg for 60 seconds
Flammability	No ignition of the tissue paper or scorching of the pinewood board	UL-94 V-0 or V-1 are acceptable. Electrical test not required

RCWV (Rated continuous working voltage) = $\sqrt{P \cdot R}$ or Maximum Operating Voltage whichever is less

NFR0102 Single Pulse

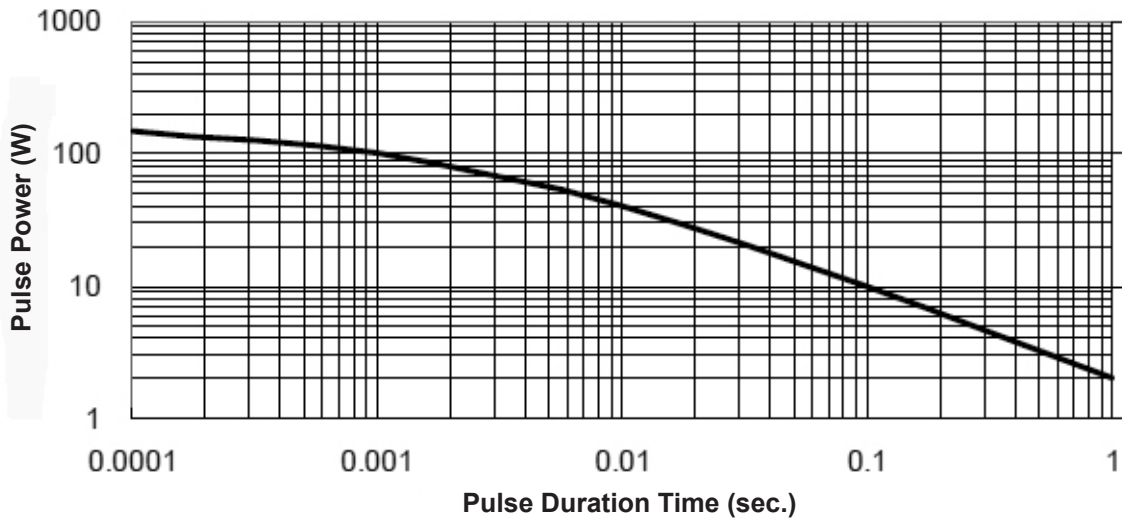

NFR0204/0207 Single Pulse (100Ω)

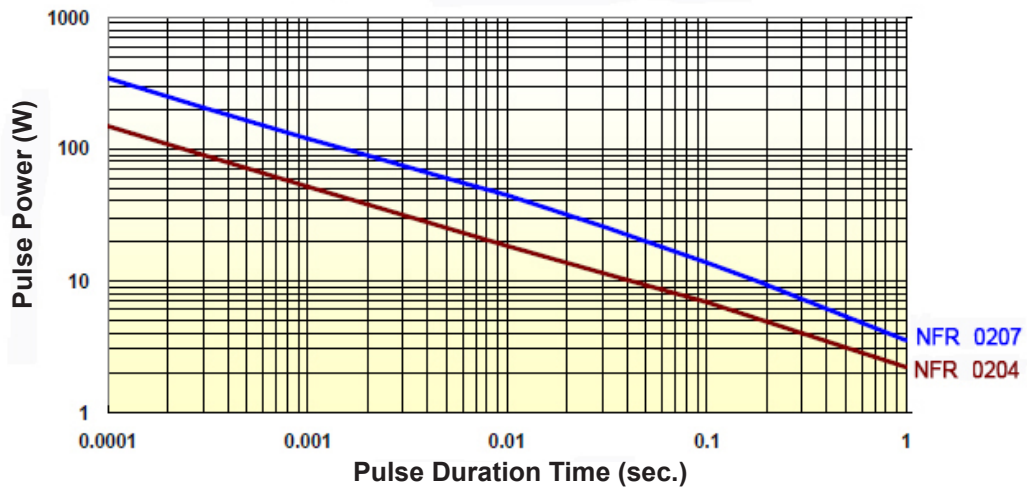

NFR0102 Continuous Pulse

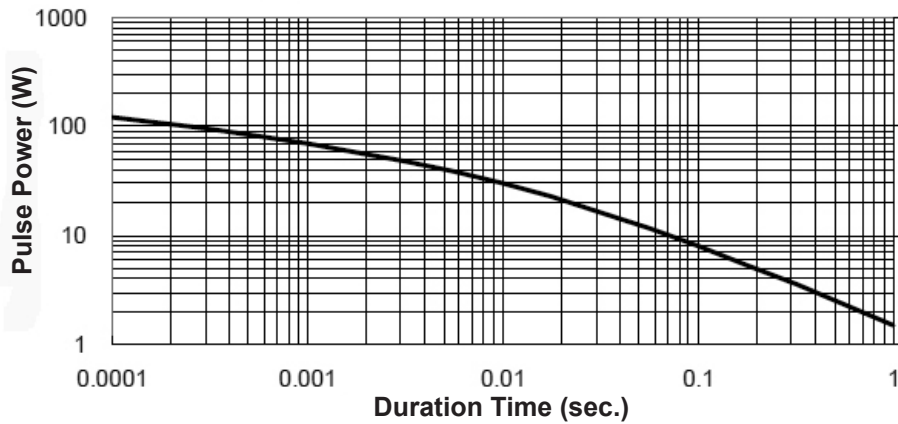

NFR0204/0207 Continuous Pulse (100Ω)

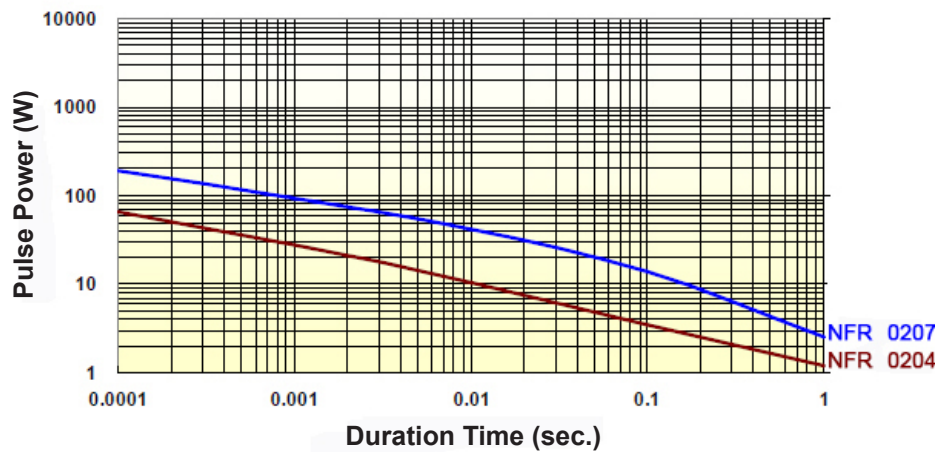

NFR0204/0207 Pulse Voltage (100Ω)

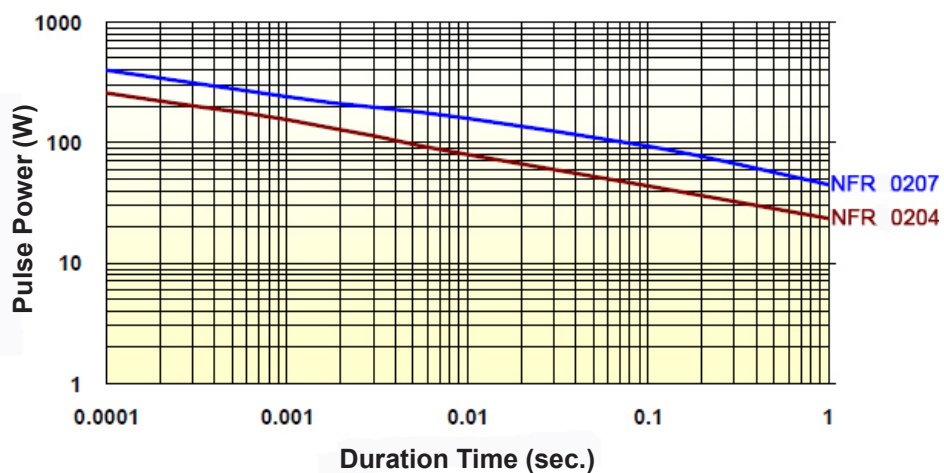

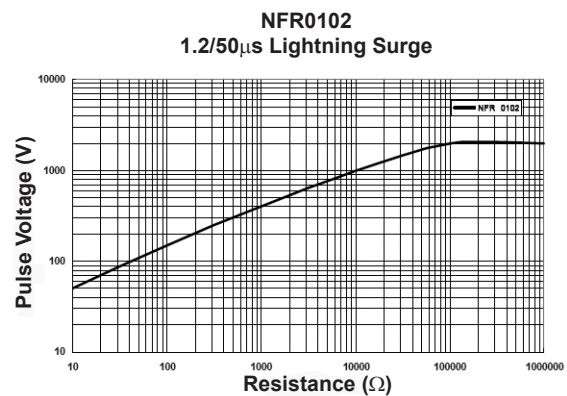
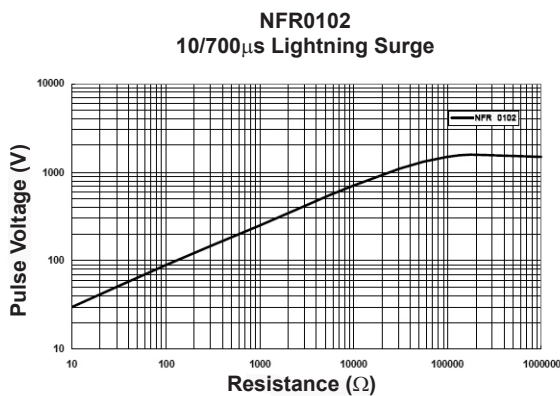
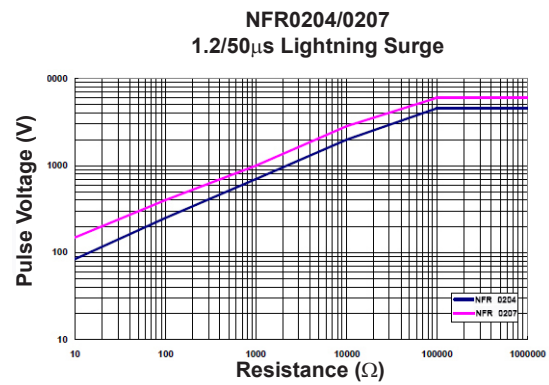
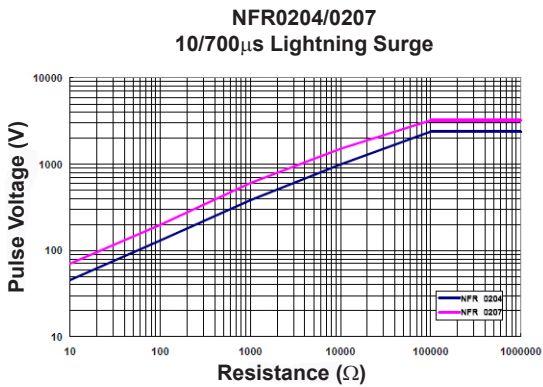
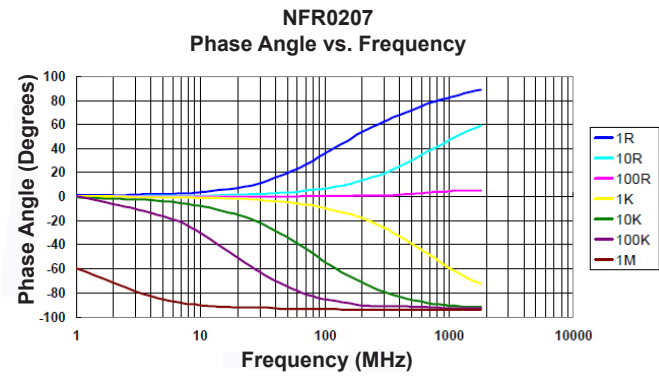
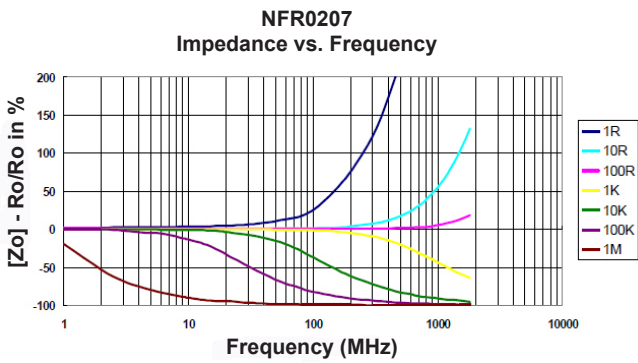
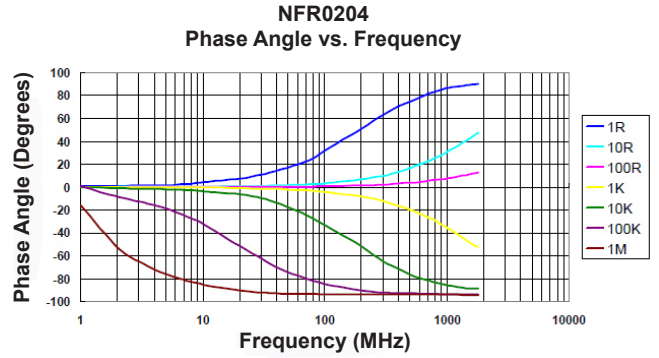
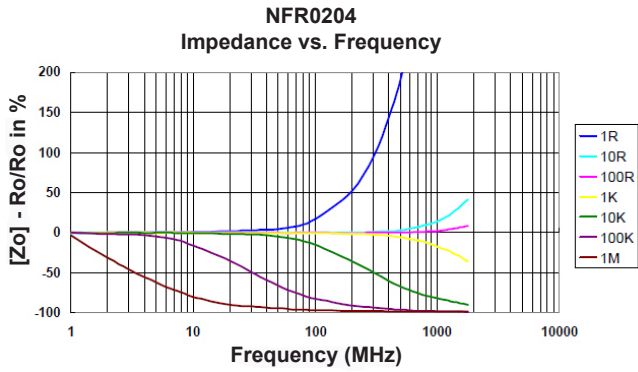

Note *1 - Maximum allowable continuous Working Voltage for all resistors is the lower of the two values:

“Maximum Working Voltage” as specified above or the result of the following formula

$$\sqrt{\text{Power rating (Watts)} \times \text{Resistance (Ohms)}}$$

Note * - Maximum Overload Voltage for all resistors is the lower of the two values:

“Maximum Overload Voltage” as specified above or the result of the following formula

$$2.5x \sqrt{\text{Power rating (Watts)} \times \text{Resistance (Ohms) for 5 sec.}}$$

Power Derating Curve: For operation above 70°C, power rating must be derated according to the following chart:

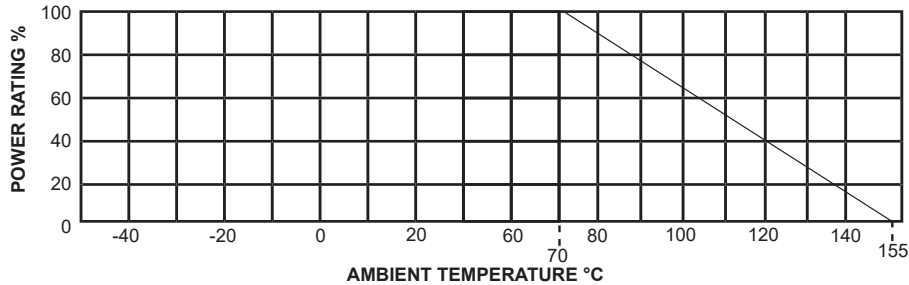

COLOR CODING

Color	Significant Figure			Multiplier
	1st	2nd	3rd*	
Black	0	0	0	1
Brown	1	1	1	10
Red	2	2	2	100
Orange	3	3	3	1,000
Yellow	4	4	4	10,000
Green	5	5	5	100,000
Blue	6	6	6	1,000,000
Violet	7	7	7	10,000,000
Grey	8	8	8	-
White	9	9	9	-
Gold	-	-	-	0.1
Silver	-	-	-	0.01

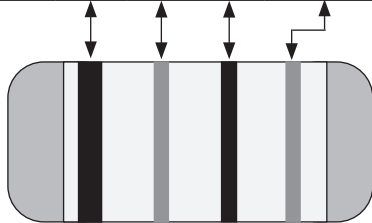

Note: 3 bands for 2%* & 5% tolerance parts,
4 bands for 1% tolerance parts.

*2% tolerance parts identified by reel label
(R<1 ohm with more than two significant figures will not be marked. Ex. value 0.249Ω has no marking)

ZERO OHM MARKING



E-24 & E-96 VALUES

E-24 Values	E-96 Values			
100	100	102	105	107
110	110	113	115	118
120	121	124	127	130
130	133	137	140	143
150	147	150	154	158
160	162	165	169	174
180	178	182	187	191
200	196	200	205	210
220	215	221	226	232
240	237	243	249	255
270	261	267	274	280
300	287	294	301	309
330	316	324	332	340
360	348	357	365	374
390	383	392	402	412
430	422	432	442	453
470	464	475	487	499
510	511	523	536	549
560	562	576	590	604
620	619	634	649	665
680	681	698	715	732
750	750	768	787	806
820	825	845	866	887
910	909	931	953	976

CONSTRUCTION

Item	Material
1	Insulation Coating
2	Marking
3	Cutting Line
4	Ceramic Core
5	Resistive Film
6	Terminal

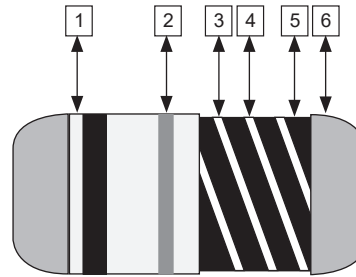

LAND PATTERN DIMENSIONS (mm)

Type	Case Size	A	B	C
NFR0102	0102	1.5	0.8	1.0
NFR0204	0204	1.6	1.2	1.6
NFR0207	0207	2.4	1.7	3.0

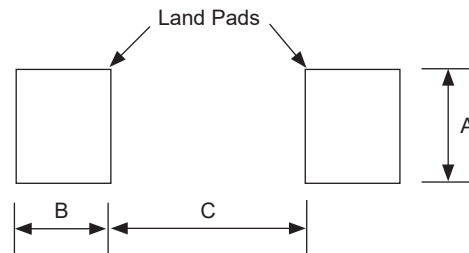

Reflow Soldering Heat Profile and Limits

→ www.niccomp.com/resource/files/resistive/NIC-ChipR-Reflow-Sept2020-Rev2.pdf
 Wave soldering? – Please review your wave soldering process profile with NIC: tpmg@niccomp.com

CARRIER TAPE DIMENSIONS (mm)

Type	Case Size	A	B	W	F	E	D	D ₁	P ₀	P ₁	P ₂	T
NFR0102	0102	1.30±0.1	2.40±0.1	8.0±0.1	3.5±0.05	1.75±0.1	1.5±0.1	0.9 min	4.0±0.1	4.0±0.1	2.0±0.1	1.50±0.1
NFR0204	0204	1.60±0.1	3.70±0.1	8.0±0.1	3.5±0.05	1.75±0.1	1.5±0.1	0.9 min	4.0±0.1	4.0±0.1	2.0±0.1	1.87±0.1
NFR0207	0207	2.4±0.1	6.05±0.1	12.0±0.1	5.5±0.05	1.75±0.1	1.5±0.1	1.4 min.	4.0±0.1	4.0±0.1	2.0±0.1	2.80±0.1

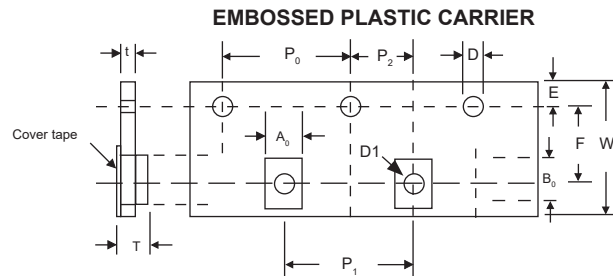

REEL DIMENSIONS AND QUANTITY (mm)

Type	Case Size	A	B	C	W	T	Qty
NFR0102	0102	178 ± 1.5	60.0 ± 1.0	13.0 ± 0.2	9.0 ± 0.5	12.0 ± 0.15	3,000
NFR0204	0204						
NFR0207	0207	178 ± 1.5	60.0 ± 1.0	13.0 ± 0.5	13.2 ± 0.5	15.5 ± 0.20	2,000

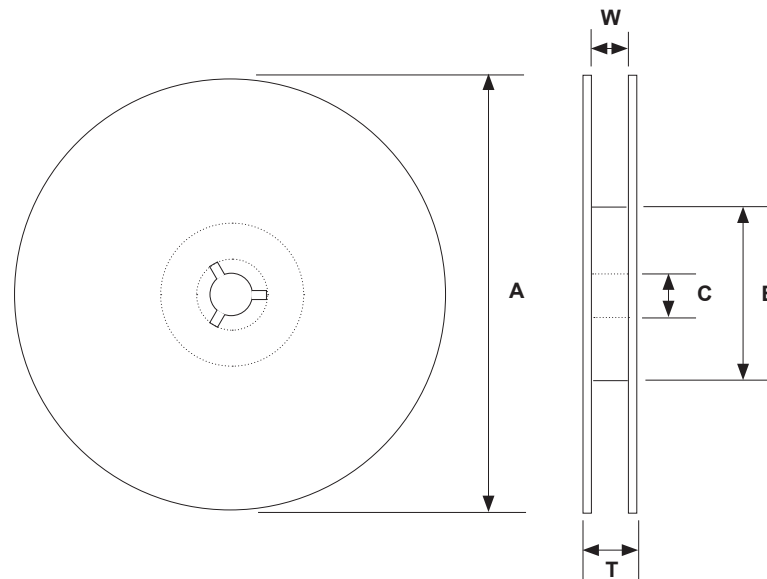

[Legacy Part Numbers]
(Supported for existing business from establish customers)

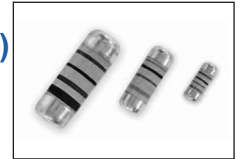

FEATURES

- SURFACE MOUNT IN SIZES 0102 (0805), 0204 (1406) AND 0207 (2410)
- THIN FILM CONSTRUCTION
- AVAILABLE IN PRECISION TOLERANCE AND TC (TO ±0.1% TOL. AND ±10PPM TC)
- ALL SIZES ARE AVAILABLE IN TAPE/REEL FOR AUTOMATIC MOUNTING
- SAC REFLOW SOLDERABLE (+260°C FOR 3 SECONDS)
- AVAILABLE IN ZERO OHM JUMPER

STANDARD POWER SPECIFICATIONS

Type	Size	Power Rating at 70°C	Max. *1 Working Voltage	Max. *2 Overload Voltage	Resistance Tolerance Code	Temperature Coefficient (ppm/°C)	Resistance Range (Ω)*3	Resistance Values	Operating Temperature Range
NFR0102W	0102 (0805)	0.125W	150V	300V	±0.1% (B) ±0.25% (C) ±0.5% (D) ±1% (F)	±15 (N)	100 ~ 56K	E-24 & E-96	-55°C ~ +155°C
					±0.1% (B) ±0.25% (C) ±0.5% (D) ±1% (F)	±25 (C)	100 ~ 82K		
					±0.5% (D) ±1% (F)		49.9 ~ 200K 49.9 ~ 390K		
					±0.5 (D) ±1% (F)	±50 (D)	8.2 ~ 1M	E-24	
					±5% (J)		±100 (E)	40.2 ~ 1M	
					±1% (F) ±5% (J)				
					NFR0204V	0204 (1406)	0.25W	200V	
±0.1% (B) ±0.25% (C) ±0.5% (D) ±1% (F)	±15 (N)	10 ~ 300K							
±0.1% (B) ±0.25% (C) ±0.5% (D) ±1% (F)	±25 (C)	10 ~ 1M	E-24						
±0.5% (D) ±1% (F)		1.0 ~ 4.7M							
±0.1% (B) ±0.25% (C) ±0.5% (D) ±1% (F)	±50 (D)	10 ~ 1M							
±1% (F)		1.0 ~ 1M							
±5% (J)	±100 (E)	0.2 ~ 10M	E-24						
±1% (F) ±5% (J)		0.1 ~ 10M	E-24 & E-96 E-24						

Continued Next Page

DIMENSIONS (mm)

Type	Size	L	D	C
NFR0102	0102	2.2 ± 0.1	1.10 ± 0.10	0.4 min.
NFR0204	0204	3.5 ± 0.2	1.40 ± 0.15	0.5 min.
NFR0207	0207	5.9 ± 0.2	2.20 ± 0.20	0.5 min.

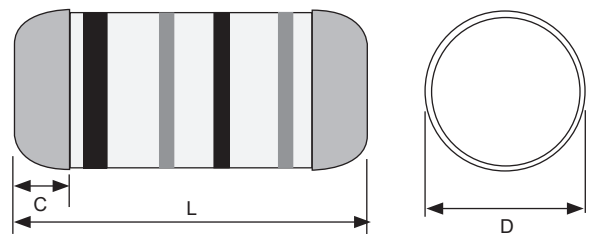

[Legacy Part Numbers]
(Supported for existing business from establish customers)

STANDARD POWER SPECIFICATIONS

Type	Size	Power Rating at 70°C	Max. *1 Working Voltage	Max. *2 Overload Voltage	Resistance Tolerance Code	Temperature Coefficient (ppm/°C)	Resistance Range (Ω)*3	Resistance Values	Operating Temperature Range	
NFR0207U	0207 (2410)	0.50W	300V	600V	±0.1% (B) ±0.25% (C) ±0.5% (D) ±1% (F)	±10 (B)	10 ~ 20K	E-24 & E-96	-55°C ~ +155°C	
					±0.1% (B) ±0.25% (C) ±0.5% (D) ±1% (F)	±15 (N)	10 ~ 300K			
					±0.1% (B) ±0.25% (C) ±0.5% (D) ±1% (F)	±25 (C)	10 ~ 1M			
					±1% (F)		1.0 ~ 4.7M			
					±0.1% (B) ±0.25% (C) ±0.5% (D) ±1% (F)	±50 (D)	10 ~ 1M			
					±0.25% (C) ±0.5% (D) ±1% (F)		1.0 ~ 1M			
					±1% (F)		0.2 ~ 10M			
					±5% (J)		0.2 ~ 10M			
					±1% (F) ±5% (J)	±100 (E)	0.1 ~ 10M			E-24 & E-96
					±5% (J)		0.1 ~ 10M			E-24

HIGH POWER SPECIFICATIONS

Type	Size	Power Rating at 70°C	Max. *1 Working Voltage	Max. *2 Overload Voltage	Resistance Tolerance Code	Temperature Coefficient (ppm/°C)	Resistance Range (Ω)*3	Resistance Values	Operating Temperature Range	
NFR0102P	0102 (0805)	0.20W	200V	400V	±0.1% (B) ±0.25% (C) ±0.5% (D) ±1% (F)	±15 (N)	100 ~ 56K	E-24 & E-96	-55°C ~ +155°C	
					±0.1% (B) ±0.25% (C) ±0.5% (D) ±1% (F)	±25 (C)	100 ~ 82K			
					±0.5% (D) ±1% (F)		49.9 ~ 200K			
					±0.5 (D) ±1% (F)	±50 (D)	49.9 ~ 390K			
					±5% (J)		8.2 ~ 1M			E-24
					±1% (F) ±5% (J)	±100 (E)	40.2 ~ 1M			E-24 & E-96
					±5% (J)		E-24			
NFR0204G	0204 (1406)	0.40W	200V	400V	±0.1% (B) ±0.25% (C) ±0.5% (D) ±1% (F)	±15 (N)	10 ~ 100K	E-24 & E-96		
					±0.1% (B) ±0.25% (C) ±0.5% (D) ±1% (F)	±25 (C)	10 ~ 1.0M			
					±1% (F) ±5% (J)		1.0 ~ 3.4M		E-24	
					±0.1% (B) ±0.25% (C) ±0.5% (D) ±1% (F)	±50 (D)	10 ~ 1.0M			
					±1% (F) ±5% (J)		1.0 ~ 1.0M		E-24 & E-96	
					±1% (F) ±5% (J)		0.2 ~ 1.0M		E-24	
					±1% (F) ±5% (J)		±100 (E)		0.1 ~ 1.0M	E-24 & E-96
					±5% (J)	0.1 ~ 1.0M			E-24	

Continued Next Page

[Legacy Part Numbers]
(Supported for existing business from establish customers)

HIGH POWER SPECIFICATIONS

Type	Size	Power Rating at 70°C	Max. *1 Working Voltage	Max. *2 Overload Voltage	Resistance Tolerance Code	Temperature Coefficient (ppm/°C)	Resistance Range (Ω)*3	Resistance Values	Operating Temperature Range
NFR0207T	0207 (2410)	1.0W	350V	700V	±0.1% (B)	±15 (N)	10 ~ 100K	E-24 & E-96	-55°C ~ +155°C
					±0.25% (C)				
					±0.5% (D)				
					±1% (F)	±25 (C)	10 ~ 1.0M	E-24	
					±0.1% (B)				
					±0.25% (C)				
					±0.5% (D)				
					±1% (F)	±50 (D)	10 ~ 1.0M	E-24 & E-96	
					±5% (J)				
					±0.1% (B)				
±0.25% (C)									
±0.5% (D)									
±1% (F)	±100 (E)	0.1 ~ 10M	E-24 & E-96						
±5% (J)									
±1% (F)									
±5% (J)									

ZERO OHM JUMPER SPECIFICATIONS

Type	Size	Maximum Current	Maximum Resistance	Operating Temperature Range
NFR0102ZOTRF	0102	Max. current 2A	Max. resistance 15mΩ	-55°C ~ +155°C
NFR0204ZOTRF	0204	Max. current 2A	Max. resistance 15mΩ	
NFR0207ZOTRF	0207	Max. current 4A	Max. resistance 15mΩ	

PART NUMBER SYSTEM (0.1%, 0.25%, 0.5%, 1% TOLERANCE E-24 & E-96 VALUES)

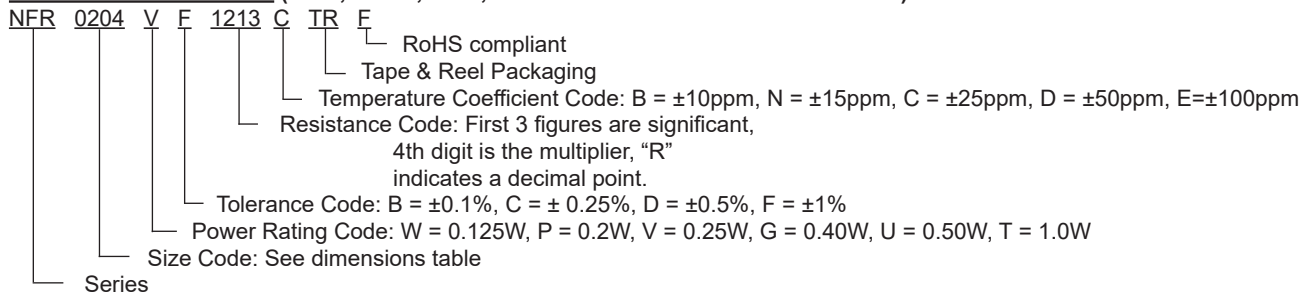

PART NUMBER SYSTEM (5% E-24 VALUES)

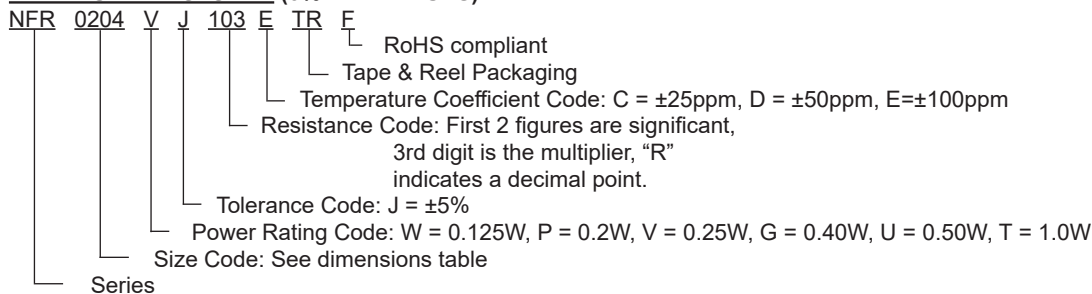

[Legacy Part Numbers]
(Supported for existing business from establish customers)

ENVIRONMENTAL CHARACTERISTICS

Item	Specification	Test Method
Temperature Coefficient of Resistance (TCR)	As specified	JIS-C-5201-1 4.8 IEC-60115-1 4.8 -55°C ~ +125°C, +25 is reference temperature
Short Time Overload	0204/0207: $\pm(0.15\%+0.05\Omega)$ 0102: $\pm(0.5\%+0.05\Omega)$	JIS-C-5201-1 4.13 IEC-60115-1 4.13 RCWV*2.5 or Max. Overload Voltage whichever is less for 5 seconds
Insulation Resistance	$\geq 10G\Omega$	JIS-C-5201-1 4.6 IEC-60115-1 4.6 Max. Overload Voltage for 1 minute
Endurance	0204/0207: $\pm(0.5\%+0.05\Omega)$ 0102: $\pm(1.5\%+0.05\Omega)$	JIS-C-5201-1 4.25 IEC-60115-1 4.25.1 +70°C \pm 2°C, RCWV for 1000 hrs with 1.5 hrs "ON" and 0.5 hrs "OFF"
Damp Heat with Load	0204/0207: $\pm(1.0\%+0.05\Omega)$ 0102: $\pm(1.5\%+0.05\Omega)$	JIS-C-5201-1 4.24 IEC-60115-1 4.24 +40°C \pm 2°C, 90~95% RH, RCWV for 1000 hrs with 1.5 hrs "ON" and 0.5 hrs "OFF"
Dry Heat	0204/0207: $\pm(1.0\%+0.05\Omega)$ 0102: $\pm(1.5\%+0.05\Omega)$	JIS-C-5201-1 4.23 IEC-60115-1 4.23.2 +155°C for 1000 hrs
Bending Strength	$\pm(0.5\%+0.05\Omega)$	JIS-C-5201-1 4.33 IEC-60115-1 4.33 Bend once for 5 seconds 2mm
Solderability	95% minimum coverage	JIS-C-5201-1 4.17 IEC-60115-1 4.17 +245°C \pm 5°C for 3 seconds
Resistance to Soldering Heat	$\pm(0.5\%+0.05\Omega)$	JIS-C-5201-1 4.18 IEC-60115-1 4.18 +260°C for 10 seconds
Voltage Proof	No breakdown or flashover	JIS-C-5201-1 4.7 IEC-60115-1 4.7 1.42 times Max. Operating Voltage for 1 minute
Leaching	individual leaching area $\leq 5\%$ Total leaching area $\leq 10\%$	JIS-C-5201-1 4.18 IEC-60068-2-58 8.2.1 +260°C \pm 5°C for 30 seconds
Rapid Change in Temperature	$\pm(0.5\%+0.05\Omega)$	JIS-C-5201-1 4.19 IEC-60115-1 4.19 -55°C ~ +155°C, 5 cycles

RCWV (Rated continuous working voltage) = $\sqrt{P \cdot R}$ or Maximum Operating Voltage whichever is less

[Legacy Part Numbers]
(Supported for existing business from establish customers)

Note *1 - Maximum allowable continuous Working Voltage for all resistors is the lower of the two values:

“Maximum Working Voltage” as specified above or the result of the following formula

$$\sqrt{\text{Power rating (Watts)} \times \text{Resistance (Ohms)}}$$

Note * - Maximum Overload Voltage for all resistors is the lower of the two values:

“Maximum Overload Voltage” as specified above or the result of the following formula

$$2.5 \times \sqrt{\text{Power rating (Watts)} \times \text{Resistance (Ohms) for 5 sec.}}$$

Power Derating Curve: For operation above 70°C, power rating must be derated according to the following chart:

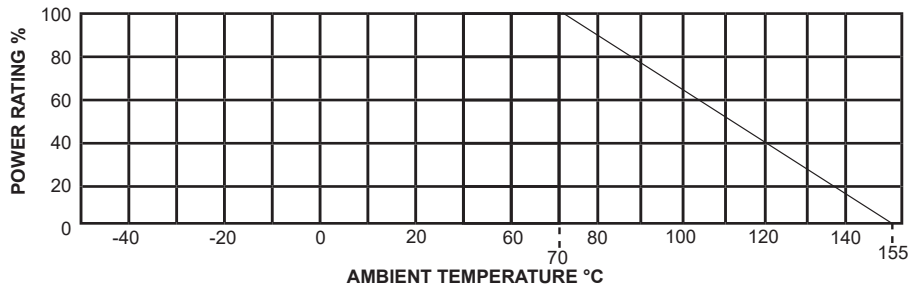

COLOR CODING

Color	Significant Figure			Multiplier
	1st	2nd	3rd*	
Black	0	0	0	1
Brown	1	1	1	10
Red	2	2	2	100
Orange	3	3	3	1,000
Yellow	4	4	4	10,000
Green	5	5	5	100,00
Blue	6	6	6	1,000,000
Violet	7	7	7	10,000,000
Grey	8	8	8	-
White	9	9	9	-
Gold	-	-	-	0.1
Silver	-	-	-	0.01

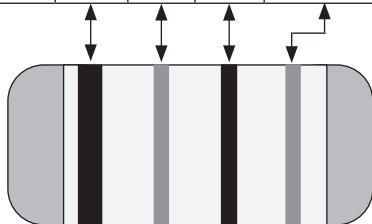

Note: 3 bands for 2%* & 5% tolerance parts,
 4 bands for 1% tolerance parts.

*2% tolerance parts identified by reel label
 (R<1 ohm with more than two significant figures will not be marked. Ex. value 0.249Ω has no marking)

E-24 & E-96 VALUES

E-24 Values	E-96 Values			
	100	102	105	107
110	110	113	115	118
120	121	124	127	130
130	133	137	140	143
150	147	150	154	158
160	162	165	169	174
180	178	182	187	191
200	196	200	205	210
220	215	221	226	232
240	237	243	249	255
270	261	267	274	280
300	287	294	301	309
330	316	324	332	340
360	348	357	365	374
390	383	392	402	412
430	422	432	442	453
470	464	475	487	499
510	511	523	536	549
560	562	576	590	604
620	619	634	649	665
680	681	698	715	732
750	750	768	787	806
820	825	845	866	887
910	909	931	953	976

ZERO OHM MARKING



[Legacy Part Numbers]
 (Supported for existing business from establish customers)

CONSTRUCTION

Item	Material
1	Insulation Coating
2	Marking
3	Cutting Line
4	Ceramic Core
5	Resistive Film
6	Terminal

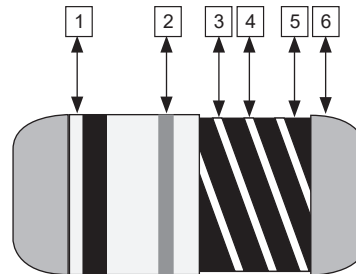

LAND PATTERN DIMENSIONS (mm)

Type	Case Size	A	B	C
NFR0102	0102	1.5	0.8	1.0
NFR0204	0204	1.6	1.2	1.6
NFR0207	0207	2.4	1.7	3.0

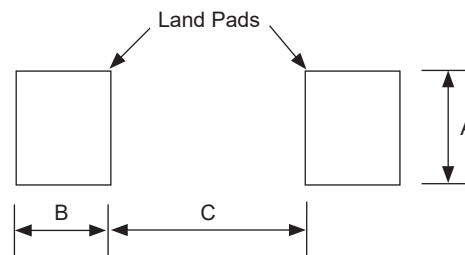

Reflow Soldering Heat Profile and Limits

→ www.nicomp.com/resource/files/resistive/NIC-ChipR-Reflow-Sept2020-Rev2.pdf
 Wave soldering? – Please review your wave soldering process profile with NIC: tpmg@nicomp.com

[Legacy Part Numbers]
(Supported for existing business from establish customers)

CARRIER TAPE DIMENSIONS (mm)

Type	Case Size	A	B	W	F	E	D	D ₁	P ₀	P ₁	P ₂	T
NFR0102	0102	1.30±0.1	2.40±0.1	8.0±0.1	3.5±0.05	1.75±0.1	1.5±0.1	0.9 min	4.0±0.1	4.0±0.1	2.0±0.1	1.50±0.1
NFR0204	0204	1.60±0.1	3.70±0.1	8.0±0.1	3.5±0.05	1.75±0.1	1.5±0.1	0.9 min	4.0±0.1	4.0±0.1	2.0±0.1	1.87±0.1
NFR0207	0207	2.4±0.1	6.05±0.1	12.0±0.1	5.5±0.05	1.75±0.1	1.5±0.1	1.4 min.	4.0±0.1	4.0±0.1	2.0±0.1	2.80±0.1

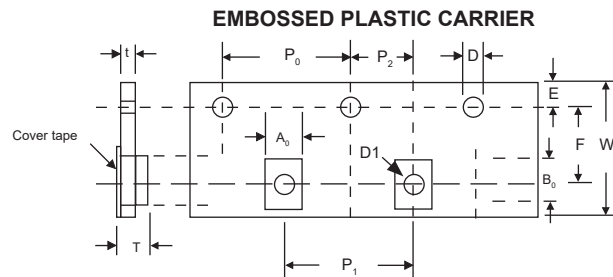

REEL DIMENSIONS AND QUANTITY (mm)

Type	Case Size	A	B	C	W	T	Qty
NFR0102	0102	178 ± 1.5	60.0 ± 1.0	13.0 ± 0.2	9.0 ± 0.5	12.0 ± 0.15	3,000
NFR0204	0204						
NFR0207	0207	178 ± 1.5	60.0 ± 1.0	13.0 ± 0.5	13.2 ± 0.5	15.5 ± 0.20	2,000

