



Z85230

ESCC™ ENHANCED SERIAL COMMUNICATION CONTROLLER

FEATURES

- Deeper data FIFOs
 - 4-byte transmit FIFO
 - 8-byte receive FIFO
- Programmable FIFO interrupt levels provide flexible interrupt response.
- Pin and function compatible to CMOS and NMOS Z85C30 SCC.
- Many improvements to support SDLC/HDLC transfers:
 - Deactivation of /RTS pin after closing flag
 - Automatic transmission of the opening flag
 - Automatic reset of Tx Underrun/EOM latch
 - Complete CRC reception
 - Tx/D pin automatically forced high with NRZI encoding when using mark idle.
 - Receive FIFO automatically unlocked for special receive interrupts when using the SDLC status FIFO.
 - Back-to-back frame transmission simplified
- Easier interface to popular CPUs
- Improved SDLC frame status FIFO
- Low power CMOS
- New programmable features added with Write Register 7'.
 - Write registers: WR3, WR4, WR5, and WR10 are now readable
 - Read Register 0 latched during access
 - Software interrupt acknowledge mode
 - DPLL counter output available as jitter-free clock source
 - /DTR/REQ pin deactivation time reduced
 - Two independent full-duplex channels, each with a crystal oscillator, baud rate generator, and digital phase-locked loop.
 - Multi-protocol operation under program control
 - Asynchronous mode with five-to-eight bits, and one, one and one-half, or two stop bits per character; programmable clock factor; break detection and generation; parity, overrun, and framing error detection.
 - Synchronous mode with internal or external character synchronization on one or two synchronous characters and CRC generation and checking with programmable CRC preset values.

GENERAL DESCRIPTION

The Zilog Z85230 Enhanced Serial Communications Controller (ESCC), is a pin and software compatible CMOS member of the SCC™ Family. (The SCC was introduced by Zilog in 1981.) The ESCC is a dual-channel, full-duplex data communications controller capable of supporting a wide range of popular protocols. The ESCC is built from

Zilog's industry standard SCC core and is compatible with designs using Zilog's SCC to receive and transmit data. It has many improvements that significantly reduce CPU overhead. The addition of a 4-byte transmit FIFO and an 8-byte receive FIFO significantly reduces the overhead required to provide data to, and get data from, the transmitters and receivers.

GENERAL DESCRIPTION (Continued)

The ESCC also has many features that improve packet handling in SDLC mode. The ESCC will automatically: transmit a flag before the data, reset the Tx Underrun/EOM latch, force the TxD pin high at the appropriate time when using NRZI encoding, deassert the /RTS pin after the closing flag, and better handle ABORTed frames when using the 10x19 status FIFO. The combination of these features along with the deeper data FIFOs significantly simplifies SDLC driver software.

The CPU hardware interface has been simplified by relieving the databus setup time requirement and supporting the software generation of the interrupt acknowledge signal (/INTACK). These changes allow an interface with less external logic to many microprocessor families while maintaining compatibility with existing designs. I/O handling of the ESCC is improved over the SCC with faster response of the /INT and /DTR//REQ pins.

The many enhancements added to the ESCC permits a system design that increases overall system performance with better data handling and less interface logic (Figure 1).

Notes:

All Signals with a preceding front slash, "/", are active Low, e.g.: B//W (WORD is active Low); /B//W (BYTE is active Low, only).

Power connections follow conventional descriptions below:

Connection	Circuit	Device
Power Ground	V_{cc} GND	V_{DD} V_{SS}

Channel A
Exploded View

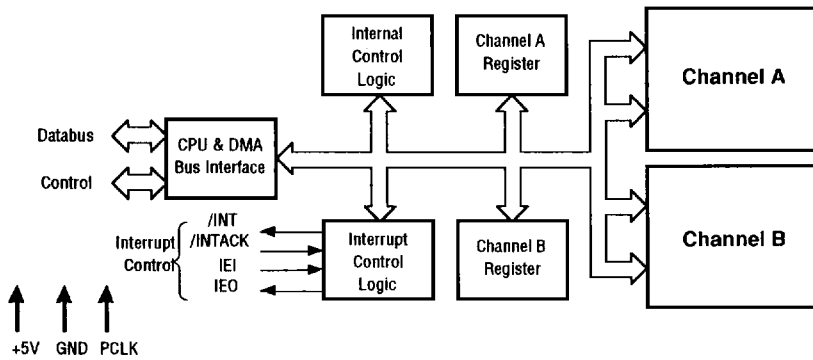
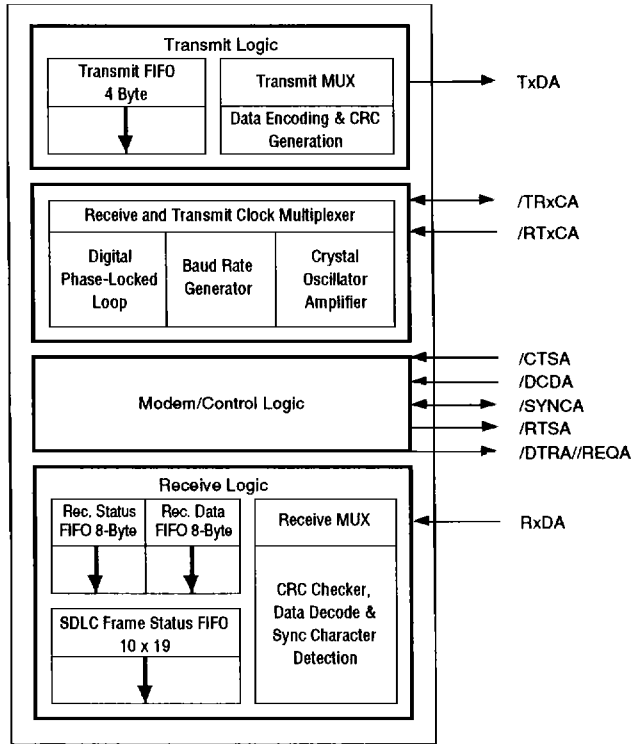

Figure 1. ESCC Block Diagram

PIN DESCRIPTIONS

The following section describes the Z85230 pin functions. Figures 2 and 3 detail the pin assignments for the 40-pin DIP and 44-pin PLCC packages. The Z85230 ESCC is socket compatible with the Zilog Z8530 and Z85C30 as the

pin electrical characteristics and pin assignments are the same. Any unused input pins should be pulled up to the +5V supply.

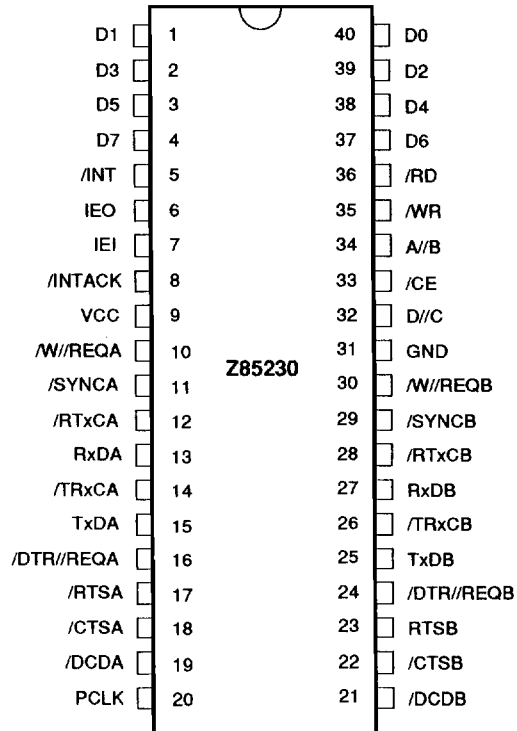

Figure 2. Z85230 DIP Pin Assignments

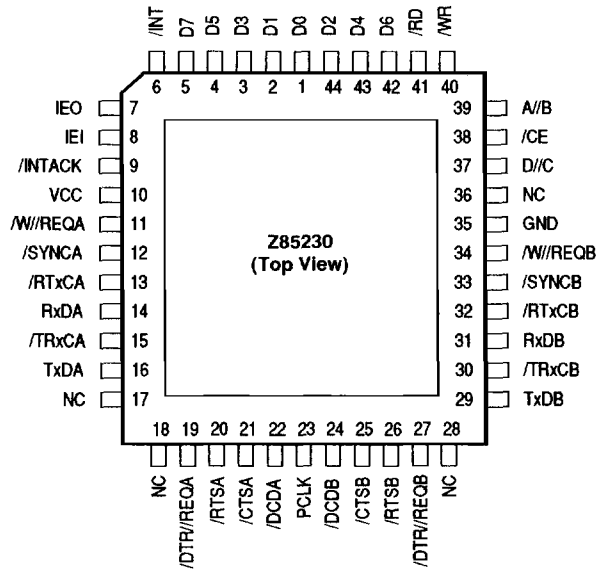

Figure 3. Z85230 LCC Pin Assignments

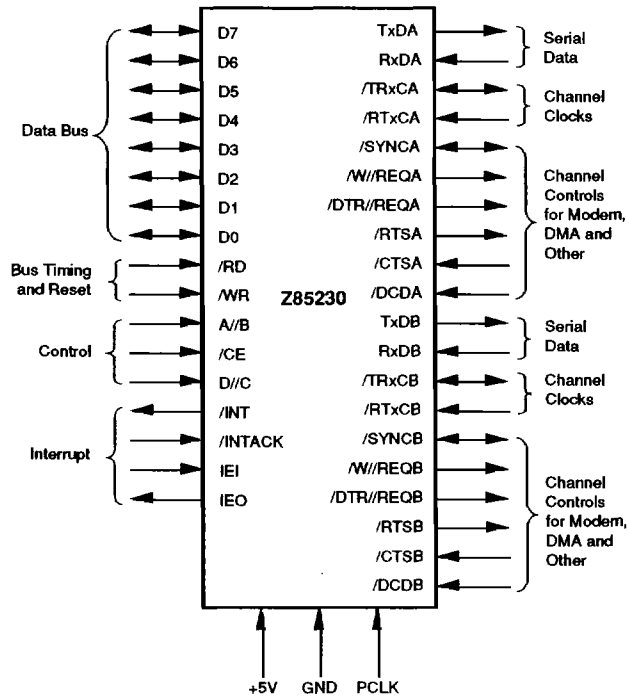

Figure 4. Z85230 Pin Functions

PIN DESCRIPTIONS

/CTSA, /CTSB. *Clear To Send* (inputs, active Low) These pins function as transmitter enables if they are programmed for Auto Enables (WR3, D5=1). A Low on the inputs enables the respective transmitters. If not programmed as Auto Enables, they may be used as a general-purpose inputs. Both inputs are Schmitt-trigger buffered to accommodate slow rise-time inputs. The ESCC detects pulses on these inputs and can interrupt the CPU on both logic level transitions.

/DCDA, /DCDB. *Data Carrier Detect* (inputs, active Low). These pins function as receiver enables if they are programmed for Auto Enables (WR3, D5=1); otherwise they are used as general-purpose input pins. Both pins are Schmitt-trigger buffered to accommodate slow rise time signals. The ESCC detects pulses on these pins and can interrupt the CPU on both logic level transitions.

/RTSA, /RTSB. *Request To Send* (outputs, active Low). The /RTS pins can be used as general purpose outputs or with the Auto Enables feature. When used with Auto Enables ON (WR3, D5=1) in asynchronous mode, the /RTS pin goes High after the transmitter is empty. When Auto Enable is OFF, the /RTS pins can be used as general purpose outputs and they strictly follow the inverse state of the RTS bit (WR5 bit D1).

In SDLC mode, the /RTS pins can be programmed to be deasserted when the closing flag of the message clears the TxD pin if WR7' D2 is set.

/SYNCA, /SYNCB. *Synchronization* (inputs or outputs, active Low). These pins can act either as inputs, outputs, or part of the crystal oscillator circuit. In the Asynchronous Receive mode (crystal oscillator option not selected), these pins are inputs similar to CTS and DCD. In this mode, transitions on these lines affect the state of the Synchronous/Hunt status bits in Read Register 0 but have no other function.

In External Synchronization mode with the crystal oscillator not selected, these lines also act as inputs. In this mode, /SYNC must be driven Low for two receive clock cycles after the last bit in the synchronous character is received. Character assembly begins on the rising edge of the receive clock immediately preceding the activation of /SYNC.

In the Internal Synchronization mode (Monosync and Bisync) with the crystal oscillator not selected, these pins act as outputs and are active only during the part of the receive clock cycle in which synchronous condition is latched. These outputs are active each time a synchronization pattern is recognized (regardless of character boundaries). In SDLC mode, the pins act as outputs and are valid on receipt of a flag. The /SYNC pins switch from input to output when monosync, bisync, or SDLC is programmed in WR4 and sync modes are enabled.

/DTR//REQA, /DTR//REQB. *Data Terminal Ready/Request* (outputs, active Low). These pins are programmed (WR14, D2) to serve either as general purpose outputs or as DMA Request lines. When programmed for the DTR function (WR14, D2=0), these outputs follow the state programmed into the DTR bit of Write Register 5 (WR5, D7). When programmed for Request mode (WR14, D2=1), these pins serve as DMA Requests for the transmitter.

When used as DMA request lines, the timing for the deactivation Request can be programmed in the added register Write Register 7' (WR7') bit D4. If this bit is set, the /DTR//Request pin will be deactivated with the same timing as the /W//REQ pin. If WR7' D4 is reset, the deactivation timing of /DTR//Req pin will be the same as in the Z85C30.

W//REQA, W//REQB. *Wait/Request* (outputs, open drain when programmed for Wait function, driven High or Low when programmed for Ready function). These dual-purpose outputs may be programmed as Request lines for a DMA controller or as Wait lines which synchronize the CPU to the ESCC data rate. The reset state is Wait.

RxDA, RxDDB. *Receive Data* (inputs, active High). These input signals receive serial data at standard TTL levels.

/RTxCA, /RTxCB. *Receive/Transmit Clocks* (inputs, active Low). These pins can be programmed to several modes of operation. In each channel, RTxC may supply the receive clock, the transmit clock, the clock for the baud rate generator, or the clock for the digital phase-locked loop. These pins can also be programmed for use with the respective SYNC pins as a crystal oscillator. The receive clock may be 1, 16, 32, or 64 times the data rate in asynchronous modes.

TxDA, TxDB. *Transmit Data* (outputs, active High). These output signals transmit serial data at standard TTL levels.

/TRxCA, /TRxCB. *Transmit/Receive Clocks* (inputs or outputs, active Low). These pins can be programmed in several different modes of operation. TRxC may supply the receive clock or the transmit clock in the input mode or supply the output of the digital phase-locked loop, the crystal oscillator, the baud rate generator, or the transmit clock in the output mode.

PCLK. *Clock* (input). This is the master ESCC clock used to synchronize internal signals. PCLK is a TTL level signal. PCLK is not required to have any phase relationship with the master system clock.

IEI. *Interrupt Enable In* (input, active High). IEI is used with IEO to form an interrupt daisy chain when there is more than one interrupt driven device. A High IEI indicates that no other higher priority device has an interrupt under service or is requesting an interrupt.

IEO. *Interrupt Enable Out* (output, active High). IEO is High only if IEI is High and the CPU is not servicing the ESCC interrupt, or the ESCC is not requesting an interrupt (Interrupt Acknowledge cycle only). IEO is connected to the next lower priority device's IEI input and thus inhibits interrupts from lower priority devices.

/INT. *Interrupt* (output, open drain, active Low). This signal is activated when the ESCC requests an interrupt. Note that /INT is an open drain output.

/INTACK. *Interrupt Acknowledge* (input, active Low). This is a strobe which indicates that an interrupt acknowledge

cycle is in progress. During this cycle, the ESCC interrupt daisy chain is resolved. The device is capable of returning an interrupt vector that may be encoded with the type of interrupt pending. During the acknowledge cycle, if IEI is High the ESCC places the interrupt vector on the databus when /RD goes active. /INTACK is latched by the rising edge of PCLK.

D7-D0. *Data bus* (bi-directional, tri-state). These lines carry data and commands to and from the ESCC.

/CE. *Chip Enable* (input, active Low). This signal selects the ESCC for a read or write operation.

/RD. *Read* (input, active Low). This signal indicates a read operation and when the ESCC is selected, enables the ESCC's bus drivers. During the Interrupt Acknowledge cycle, /RD gates the interrupt vector onto the bus if the ESCC is the highest priority device requesting an interrupt.

/WR. *Write* (input, active Low). When the ESCC is selected, this signal indicates a write operation. This indicates that the CPU wants to write command bytes or data to the ESCC write registers. The coincidence of /RD and /WR is interpreted as a reset.

A//B. *Channel A/Channel B* (input). This signal selects the channel in which the read or write operation occurs. A High selects channel A and Low selects channel B.

D//C. *Data/Control Select* (input). This signal defines the type of information transferred to or from the ESCC. A High means data is being transferred and a Low indicates a command.

FUNCTIONAL DESCRIPTION

Architecture. The architecture of the ESCC is described from two points of view: as a datacommunications device which transmits and receives data in a wide variety of protocols; and as a microprocessor peripheral in which the ESCC offers valuable features such as vectored interrupts and DMA support.

The ESCC's peripheral and datacommunication are described in the following sections. A block diagram is shown in Figure 1. The details of the communications between the receive and transmit logic to the system bus are shown in Figures 5 and 6. The features and data path for each of the ESCC's A and B channels is identical. See the ESCC Technical Manual for full details on using the ESCC.

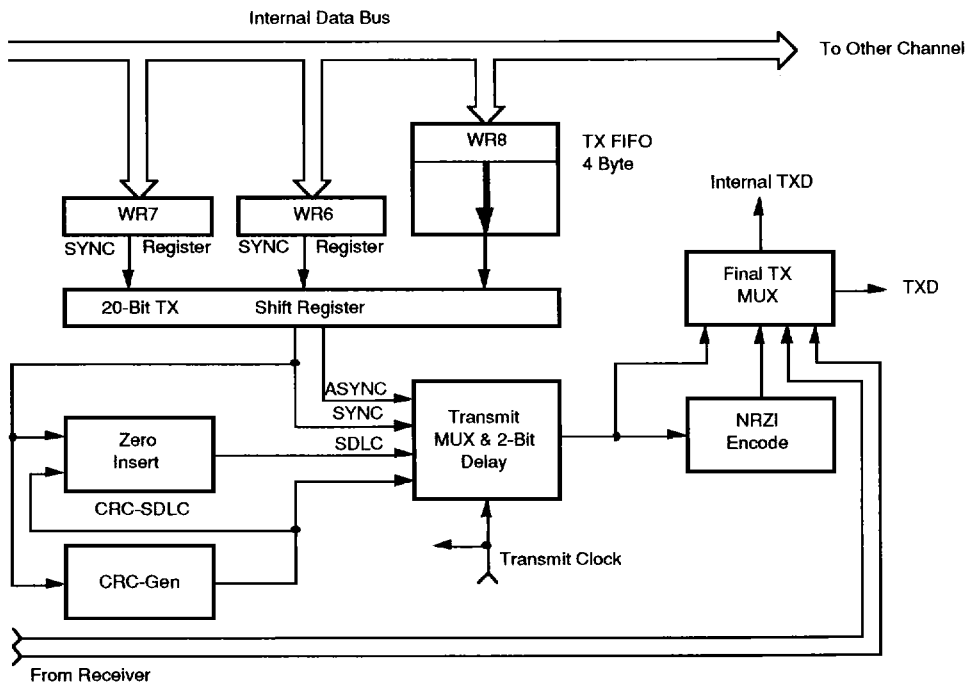

Figure 5. ESCC Transmit Data Path

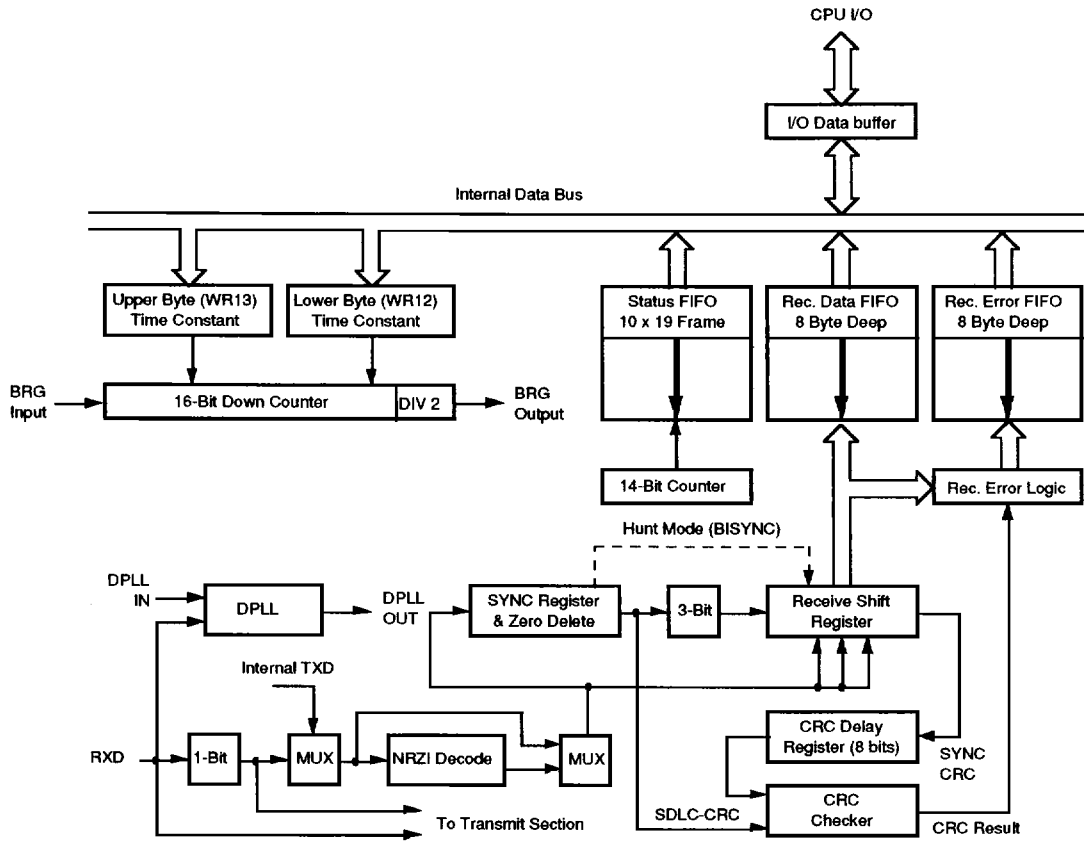

Figure 6. ESCC Receive Data Path

I/O INTERFACE CAPABILITIES

System communication to and from the ESCC is done through the ESCC's register set. There are seventeen write registers and fifteen read registers. Many of the new features on the ESCC are enabled through a new register in the ESCC: Write Register 7 Prime (WR7'). This new register can be accessed if bit D0 of WR15 is set. Table 1 lists all of the ESCC's registers and a brief description of

their functions. Throughout this document, the write and read registers are referenced with the following notation: "WR" for Write Register and "RR" for Read Register. For example:

WR4A Write Register 4 for channel A
RR3 Read Register 3 for either/both channels

Table 1. ESCC Write and Read Registers

Write Register	Functions
WR0	Command Register: Register Pointers, CRC initialization, and resets for various modes.
WR1	Interrupt conditions, Wait/DMA request control.
WR2	Interrupt Vector (accessed through either channel).
WR3	Receive and miscellaneous control parameters.
WR4	Transmit and Receive parameters and modes.
WR5	Transmit parameters and controls.
WR6	Sync character or SDLC address field.
WR7	Sync character or SDLC flag.
WR7'	SDLC enhancements enable (accessed if WR15 D0 is 1).
WR8	Transmit FIFO (4 bytes deep).
WR9	Reset commands and Master INT enable (accessed through either channel).
WR10	Miscellaneous transmit and receive controls.
WR11	Clock mode control.
WR12	Lower byte of BRG time constant.
WR13	Upper byte of BRG time constant.
WR14	Miscellaneous controls and DPLL commands.
WR15	External interrupt control.
Read Register	Functions
RR0	Transmit, Receive and external status.
RR1	Special Receive Condition status bits.
RR2A	Unmodified interrupt vector.
RR2B	Modified interrupt vector.
RR3A	Interrupt Pending bits.
RR4	WR4 status (if WR7' D6=1).
RR5	WR5 status (if WR7' D6=1).
RR6	SDLC Frame LSB Byte Count (if WR15 D2=1).
RR7	SDLC Frame 10x19 FIFO Status and MSB Byte Count (if WR15 D2=1).
RR8	Receive Data FIFO (8 Deep).
RR9	WR3 status (if WR7' D6=1).
RR10	Miscellaneous status bits.
RR11	WR10 status (if WR7' D6=1).
RR12	Lower Byte of BRG time constant.
RR13	Upper byte of BRG time constant.
RR14	WR7' status (if WR7' D6=1).

There are three choices to move data into and out of the ESCC: Polling, Interrupt (vectored and non-vectored), and Block Transfer. The Block Transfer mode can be implemented under CPU or DMA control.

Polling. When polling, all interrupts are disabled. Three status registers in the ESCC are automatically updated whenever any function is performed. For example, end-of-frame in SDLC mode sets a bit in one of these status registers. The purpose of polling is for the CPU to periodically read a status register until the register contents indicate the need for data to be transferred. Only one register needs to be read; depending on its contents, the CPU either writes data, reads data, or continues. Two bits in the register indicate the need for data transfer. An alternative is a poll of the Interrupt Pending register to determine the source of an interrupt. The status for both channels resides in one register.

Interrupts. The ESCC's interrupt structure supports vectored and nested interrupts. The fill levels where the transmit and receive FIFOs interrupt the CPU are programmable. This allows the ESCC's requests for data transfers to be tuned to the system interrupt response time.

Nested interrupts are supported with the interrupt acknowledge feature (/INTACK pin) of the ESCC. This allows the CPU to recognize the occurrence of an interrupt, and

re-enable higher priority interrupts. Because an INTACK cycle will release the /INT pin from the active state, a higher priority ESCC interrupt or another higher priority device can interrupt the CPU. When an ESCC responds to an Interrupt Acknowledge signal (INTACK) from the CPU, an interrupt vector may be placed on the data bus. This vector is written in WR2 and may be read in RR2. To speed interrupt response time, the ESCC can modify three bits in this vector to indicate status. If the vector is read in Channel A, status is never included; if it is read in Channel B, status is always included.

Each of the six sources of interrupts in the ESCC (Transmit, Receive, and External/Status interrupts in both channels) has three bits associated with the interrupt source: Interrupt Pending (IP), Interrupt Under Service (IUS), and Interrupt Enable (IE). Operation of the IE bit is straightforward. If the IE bit is set for a given interrupt source, then that source can request interrupts. The exception is when the MIE (Master Interrupt Enable) bit in WR9 is reset and no interrupts can be requested. The IE bits are write only. The other two bits are related to the interrupt priority chain (Figure 7). As a microprocessor peripheral, the ESCC may request an interrupt only when no higher priority device is requesting one, e.g., when IEI is High. If the device in question requests an interrupt, it pulls down /INT. The CPU then responds with /INTACK, and the interrupting device places the vector on the data bus.

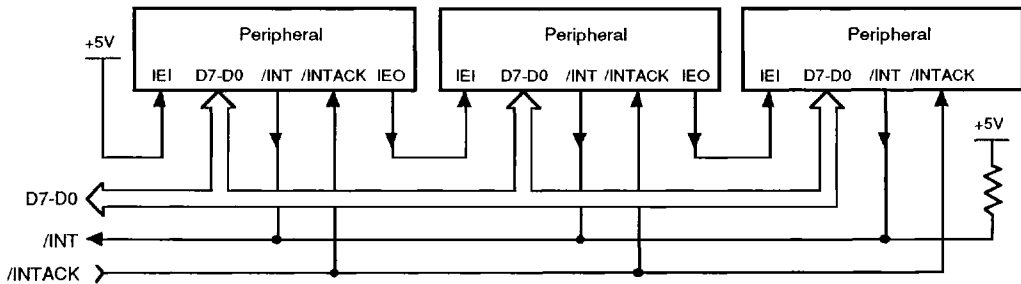

Figure 7. ESCC Interrupt Priority Schedule

I/O INTERFACE CAPABILITIES (Continued)

The ESCC can also execute an interrupt acknowledge cycle through software. In some CPU environments it is difficult to create the /INTACK signal with the necessary timing to acknowledge interrupts and allow the nesting of interrupts. In these cases, the /INTACK signal can be created with a software command to the ESCC. See the Z85230 Enhancements section for more details on this enhancement.

In the ESCC, the Interrupt Pending (IP) bit signals a need for interrupt servicing. When an IP bit is 1 and the IEI input is High, the /INT output is pulled Low, requesting an interrupt. In the ESCC, if the IE bit isn't set by enabling interrupts, then the IP for that source is never set. The IP bits are readable in RR3A.

The IUS bits signal that an interrupt request is being serviced. If an IUS is set, all interrupt sources of lower priority in the ESCC and external to the ESCC are prevented from requesting interrupts. The internal interrupt sources are inhibited by the state of the internal daisy chain, while lower priority devices are inhibited by the IEO output of the ESCC being pulled Low and propagated to subsequent peripherals. An IUS bit is set during an Interrupt Acknowledge cycle if there are no higher priority devices requesting interrupts.

There are three types of interrupts: Transmit, Receive, and External/Status. Each interrupt type is enabled under program control with Channel A having higher priority than Channel B, and with Receiver, Transmit, and External/Status interrupts prioritized in that order within each channel. When the Transmit interrupt is enabled (WR1 D1=1), the occurrence of the interrupt depends on the state of WR7' D5. If this bit is reset, the CPU is interrupted when the top byte of the transmit FIFO becomes empty. If WR7' D5 is set, the CPU is interrupted when the transmit FIFO is completely empty. (This implies that the transmitter must have had a data character written into it so that it can become empty.)

When enabled, the receiver can interrupt the CPU in one of three ways:

1. Interrupt on First Receive Character or Special Receive Condition.
2. Interrupt on All Receive Characters or Special Receive Conditions.
3. Interrupt on Special Receive Conditions Only.

If WR7' bit D3 is set, the Receive character interrupt occurs when there are four bytes available in the receive FIFO. This is most useful in synchronous applications as the data is in consecutive bytes. Interrupt on First Character or Special Condition and Interrupt on Special Condition Only are typically used with the Block Transfer mode. A special Receive Condition is one of the following: receiver overrun, framing error in Asynchronous mode, end-of-frame in SDLC mode and, optionally, a parity error. The Special Receive Condition interrupt is different from an ordinary receive character available interrupt only by the status placed in the vector during the Interrupt Acknowledge cycle. In Interrupt on First Receive Character, an interrupt occurs from Special Receive Conditions any time after the first receive character interrupt.

The main function of the External/Status interrupt is to monitor the signal transitions of the /CTS, /DCD, and /SYNC pins, however, an External/Status interrupt is also caused by a Transmit Underrun condition; a zero count in the baud rate generator; by the detection of a Break (Asynchronous mode), ABORT (SDLC mode) or EOP (SDLC Loop mode) sequence in the data stream. The interrupt caused by the ABORT or EOP has a special feature allowing the ESCC to interrupt when the ABORT or EOP sequence is detected or terminated. This feature facilitates the proper termination of the current message, correct initialization of the next message, and the accurate timing of the ABORT condition by external logic in SDLC mode. In SDLC Loop mode, this feature allows secondary stations to recognize the primary station wishes to regain control of the loop during a poll sequence.

CPU/DMA Block Transfer. The ESCC provides a Block Transfer mode to accommodate CPU block transfer functions and DMA controllers. The Block Transfer mode uses the /WAIT//REQUEST output in conjunction with the Wait/Request bits in WR1. The /WAIT//REQUEST output can be defined under software control as a WAIT line in the CPU Block Transfer mode or as a REQUEST line in the DMA Block Transfer mode.

To a DMA controller, the ESCC REQUEST output indicates that the ESCC is ready to transfer data to or from memory. To the CPU, the WAIT line indicates that the ESCC is not ready to transfer data, thereby requesting that the CPU extend the I/O cycle. The /DTR//REQUEST line allows full-duplex operation under DMA control. The ESCC can be programmed to deassert the /DTR//REQUEST pin with the same timing as the /WAIT//REQUEST pin if WR7' D4 is set.

ESCC DATA COMMUNICATIONS CAPABILITIES

The ESCC provides two independent full-duplex programmable channels for use in any common asynchronous or synchronous data communication protocols (Figure 8).

Each of the datacommunication channels has identical features and capabilities.

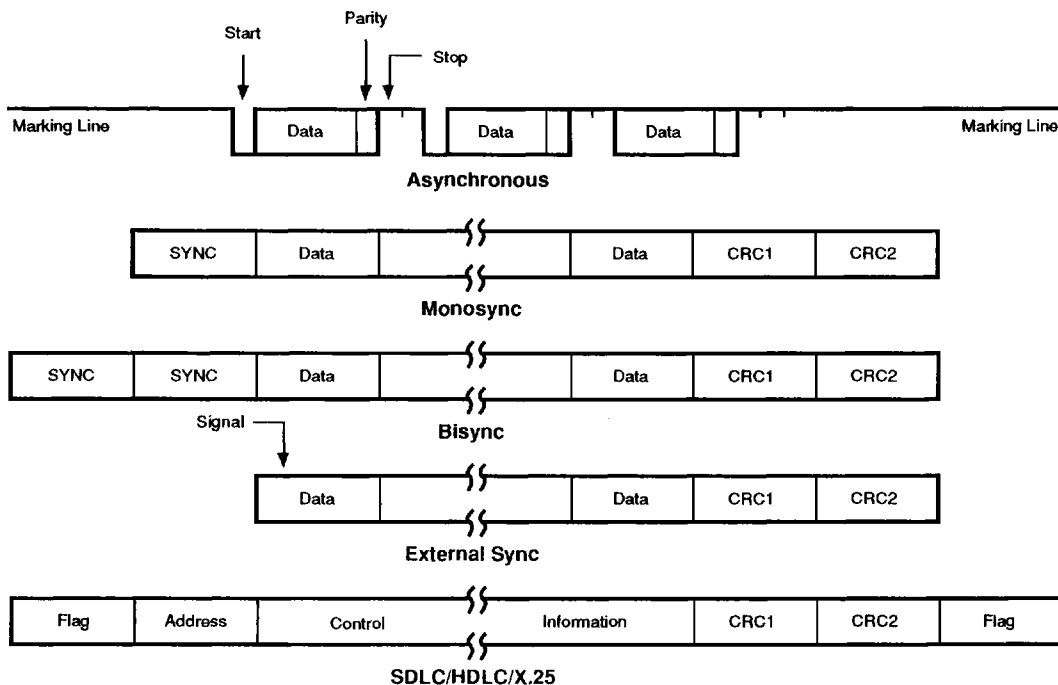

Figure 8. Some ESCC Protocols

The ESCC has significant improvements to its data communications capacity over that of the standard SCC. The addition of the deeper data FIFOs allows for data to be moved in strings instead of on a byte-by-byte basis. The ability to handle data in strings allows for significant improvements in data handling, and consequently, more efficient use of bus bandwidth. The programmability of the INT/DMA level of the FIFOs allows the system designer to determine fill levels as the FIFO's request the system to move data. The deeper data FIFOs are accessible regardless of the protocol used. They do not need to be enabled. For more details on these improvements, see the Z85230 Enhancements section of this specification.

Asynchronous Modes. Send and Receive is accomplished independently on each channel with five to eight bits per character, plus optional even or odd parity. The transmitters can supply one, one-and-a-half, or two stop bits per

character and can provide a break output at any time. The receiver break-detection logic interrupts the CPU both at the start and at the end of a received break. Reception is protected from spikes by a transient spike-rejection mechanism that checks the signal one-half a bit time after a Low level is detected on the receive data input (RxDA or RxDB pins). If the Low does not persist (e.g., a transient), the character assembly process does not start.

Framing errors and overrun errors are detected and buffered together with the partial character on which they occur. Vectored interrupts allow fast servicing of error conditions using dedicated routines. Furthermore, a built-in checking process avoids the interpretation of a framing error as a new start bit: a framing error results in the addition of one-half a bit time to the point at which the search for the next start bit begins.

ESCC DATA COMMUNICATIONS CAPABILITIES (Continued)

The ESCC does not require symmetric transmit and receive clock signals - a feature allowing use of the wide variety of clock sources. The transmitter and receiver handle data at a rate supplied to the receive and transmit clock inputs. In Asynchronous modes, the SYNC pin may be programmed as an input used for functions such as monitoring a ring indicator.

Synchronous Modes. The ESCC supports both byte-oriented and bit-oriented synchronous communication. Synchronous byte-oriented protocols are handled in several

modes. They allow character synchronization with a 6-bit or 8-bit sync character (Monosync), and a 12-bit or 16-bit synchronization pattern (Bisync), or with an external sync signal. Leading sync characters are removed without interrupting the CPU.

Five or 7-bit synchronous characters are detected with 8- or 16-bit patterns in the ESCC by overlapping the larger pattern across multiple incoming synchronous characters as shown in Figure 9.

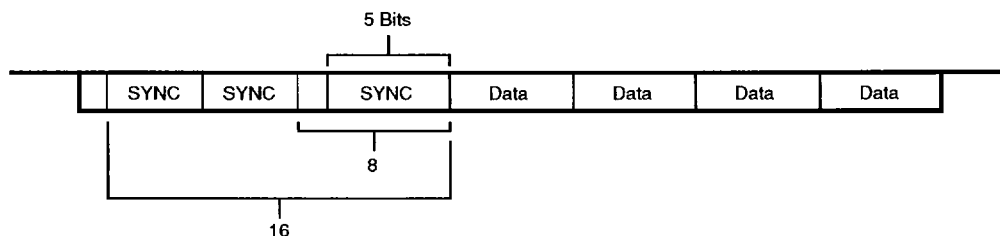

Figure 9. Detecting 5- or 7-Bit Synchronous Characters

CRC checking for Synchronous byte oriented modes is delayed by one character time so that the CPU may disable CRC checking on specific characters. This permits the implementation of protocols such as IBM Bisync.

Both CRC-16 ($X^{16} + X^{15} + X^2 + 1$) and CCITT ($X^{16} + X^{12} + X^5 + 1$) error checking polynomials are supported. Either polynomial may be selected in all Synchronous modes. Users may preset the CRC generator and checker to all 1's or all 0's. The ESCC also provides a feature that automatically transmits CRC data when no other data is available for transmission. This allows for high-speed transmissions under DMA control, with no need for CPU intervention at the end of a message. When there is no data or CRC to send in Synchronous modes, the transmitter inserts 6-, 8-, or 16-bit sync characters, regardless of the programmed character length.

SDLC Mode. The ESCC supports Synchronous bit-oriented protocols, such as SDLC and HDLC, by performing automatic flag sending, zero insertion, and CRC generation. A special command is used to abort a frame in transmission. At the end of a message, the ESCC automatically transmits the CRC and trailing flag when the transmitter underruns. The transmitter may also be programmed to send an idle line consisting of continuous flag characters or a steady marking condition.

If a transmit underrun occurs in the middle of a message, an external/status interrupt warns the CPU of this status change so that an abort can be issued. The ESCC may also be programmed to send an ABORT itself in case of an underrun, relieving the CPU of this task. One to eight bits per character can be sent, allowing reception of a message with no prior information about the character structure in the information field of a frame.

The receiver automatically acquires synchronization on the leading flag of a frame in SDLC or HDLC and provides a synchronization signal on the /SYNC pin (an interrupt can also be programmed). The receiver can be programmed to search for frames addressed by a single byte (or four bits within a byte) of a user-selected address or to a global broadcast address. In this mode, frames not matching either the user-selected or broadcast address are ignored.

The number of address bytes are extended under software control. For receiving data, an interrupt on the first received character, or an interrupt on every character, or on special condition only (end-of-frame) can be selected. The receiver automatically deletes all 0's inserted by the transmitter during character assembly. CRC is also calculated and is automatically checked to validate frame transmission. At the end of transmission, the status of a received frame is available in the status registers. In SDLC mode, the ESCC

must be programmed to use the SDLC CRC polynomial, but the generator and checker may be preset to all 1's or all 0's. The CRC is inverted before transmission and the receiver checks against the bit pattern 0001110100001111.

NRZ, NRZI or FM coding may be used in any 1x mode. The parity options available in Asynchronous modes are available in Synchronous modes.

SDLC Loop Mode. The ESCC supports SDLC Loop mode in addition to normal SDLC. In an SDLC Loop, there is a primary controller station that manages the message traffic flow on the loop and any number of secondary stations. In SDLC Loop mode, the ESCC performs the functions of a secondary station while an ESCC operating in regular SDLC mode acts as a controller (Figure 10). SDLC loop mode can be selected by setting WR10 bit D1.

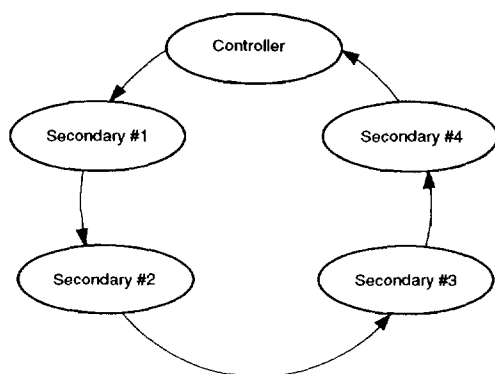

Figure 10. An SDLC Loop

A secondary station in an SDLC Loop is always listening to the messages being sent around the loop and, in fact, passes these messages to the rest of the loop by retransmitting them with a one-bit time delay. The secondary station places its own message on the loop only at specific times. The controller signals that secondary stations can transmit messages by sending a special character, called an EOP (End Of Poll), around the loop. The EOP character is the bit pattern 11111110. Because of zero insertion during messages, this bit pattern is unique and easily recognized.

When a secondary station has a message to transmit and recognizes an EOP on the line, it changes the last binary 1 of the EOP to a 0 before transmission. This has the effect of turning the EOP into a flag sequence. The secondary station now places its message on the loop and terminates the message with an EOP. Any secondary stations further down the loop with messages to transmit appends their

messages to the message of the first secondary station by the same process. Any secondary stations without messages to send merely echo the incoming message and are prohibited from placing messages on the loop (except upon recognizing an EOP). In SDLC Loop mode, NRZ, NRZI, and FM coding may all be used.

SDLC FIFO. The ESCC's ability to receive high speed back-to-back SDLC frames is maximized by a 10-bit deep by 19-bit wide status FIFO. When enabled (through WR15, bit D2), it provides the DMA the ability to continue to transfer data into memory so that the CPU can examine the message later. For each SDLC frame, a 14-bit byte count and 5 status/error bits are stored. The byte count and status bits are accessed through Read Registers 6 and 7. Read Registers 6 and 7 are only accessible when the SDLC FIFO is enabled. The 10x19 status FIFO is separate from the 8-byte receive data FIFO.

Baud Rate Generator. Each channel in the ESCC contains a programmable baud rate generator. Each generator consists of two 8-bit time constant registers that form a 16-bit time constant, a 16-bit down counter, and a flip-flop on the output producing a square wave. On startup, the flip-flop on the output is set in a High state, the value in the time constant register is loaded into the counter, and the counter starts counting down. The output of the baud rate generator toggles upon reaching 0, the value in the time constant register is loaded into the counter, and the process is repeated. The time constant may be changed at any time, but the new value does not take effect until the next load of the counter.

The output of the baud rate generator may be used as either the transmit clock, the receive clock, or both. It can also drive the digital phase-locked loop (see next section).

If the receive clock or transmit clock is not programmed to come from the TRxC pin, the output of the baud rate generator may be echoed out via the TRxC pin.

The following formula relates the time constant to the baud rate where PCLK or RTxC is the baud rate generator input frequency in Hertz. The clock mode is 1, 16, 32, or 64, as selected in Write Register 4, bits D6 and D7. Synchronous operation modes should select 1 and Asynchronous should select 16, 32 or 64.

$$\text{Time Constant} = \frac{\text{PCLK or RTxC Frequency}}{2(\text{Baud Rate}) (\text{Clock Mode})} - 2$$

ESCC DATA COMMUNICATIONS CAPABILITIES (Continued)

Digital Phase-Locked Loop. The ESCC contains a Digital Phase-Locked Loop (DPLL) to recover clock information from a data stream with NRZI or FM encoding. The DPLL is driven by a clock that is nominally 32 (NRZI) or 16 (FM) times the data rate. The DPLL uses this clock, along with the data stream, to construct a clock for the data. This clock is then used as the ESCC receive clock, the transmit clock, or both. When the DPLL is selected as the transmit clock source, it will provide a jitter free clock output that is the DPLL input frequency divided by the appropriate divisor for the selected encoding technique.

For NRZI encoding, the DPLL counts the 32x clock to create nominal bit times. As the 32x clock is counted, the DPLL is searching the incoming data stream for edges (either 1 to 0, or 0 to 1). Whenever an edge is detected, the DPLL makes a count adjustment (during the next counting cycle), producing a terminal count closer to the center of the bit cell.

For FM encoding, the DPLL still counts from 0 to 31, but with a cycle corresponding to two bit times. When the DPLL is locked, the clock edges in the data stream should occur between counts 15 and 16 and between counts 31 and 0. The DPLL looks for edges only during a time centered on the 15 to 16 counting transition.

The 32x clock for the DPLL can be programmed to come from either the RTxC input or the output of the baud rate generator. The DPLL output may be programmed to be echoed out of the ESCC via the TRxC pin (if this pin is not being used as an input).

Data Encoding. The ESCC may be programmed to encode and decode the serial data in four different ways (Figure 11). In NRZ encoding, a 1 is represented by a High level and a 0 is represented by a Low level. In NRZI encoding, a 1 is represented by no change in level and a 0 is represented by a change in level. In FM1 (more properly, bi-phase mark), a transition occurs at the beginning of every bit cell. A 1 is represented by an additional transition at the center of the bit cell and a 0 is represented by no additional transition at the center of the bit cell. In FM0 (bi-phase space), a transition occurs at the beginning of every bit cell. A 0 is represented by an additional transition at the center of the bit cell, and a 1 is represented by no additional transition at the center of the bit cell. In addition to these four methods, the ESCC can be used to decode

Manchester (bi-phase level) data by using the DPLL in the FM mode and programming the receiver for NRZ data. Manchester encoding always produces a transition at the center of the bit cell. If the transition is 0 to 1, the bit is a 0. If the transition is 1 to 0, the bit is a 1.

Auto Echo and Local Loopback. The ESCC is capable of automatically echoing everything it receives. This feature is useful mainly in Asynchronous modes, but works in Synchronous and SDLC modes as well. Auto Echo mode (TxD is RxD) is used with NRZI or FM encoding with no additional delay because the data stream is not decoded before retransmission. In Auto Echo mode, the /CTS input is ignored as a transmitter enable (although transitions on this input can still cause interrupts if programmed to do so). In this mode, the transmitter is actually bypassed and the programmer is responsible for disabling transmitter interrupts and /WAIT//REQUEST on transmit.

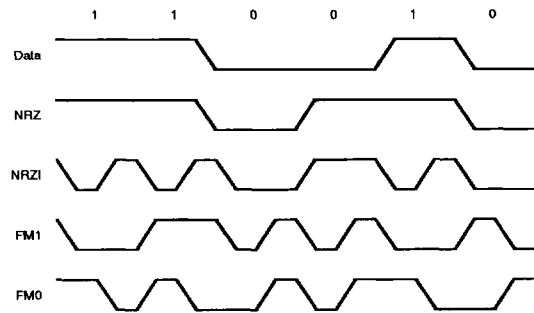

Figure 11. Data Encoding Methods

The ESCC is also capable of Local Loopback. In this mode, TxD or RxD is just like Auto Echo mode. However, in Local Loopback mode the internal transmit data is tied to the internal receive data and RxD is ignored (except to be echoed out via TxD). The /CTS and /DCD inputs are also ignored as transmit and receive enables. However, transitions on these inputs can still cause interrupts. Local Loopback works in Asynchronous, Synchronous and SDLC modes with NRZ, NRZI or FM coding of the data stream.

Z85230 ENHANCEMENTS

The following is a detailed description of the enhancements to the Z85230, ESCC from the standard SCC.

4-Byte Deep Transmit FIFO

The ESCC has a 4-byte transmit buffer with programmable interrupt and DMA request levels. It is not necessary to enable the FIFO as it is always available. The user can choose to have the Transmit Buffer Empty (TBE) interrupt and DMA Request on Transmit be generated either when the top byte of transmit FIFO is empty or only when the FIFO is completely empty. A hardware or channel reset will reset the transmit shift register, flush the transmit FIFO, and set WR7' D5=1.

If the transmitter generates the Interrupt or DMA request for data when the top byte of the FIFO is empty (WR7' D5=0), the system can allow for a long response time to the data request without underflowing. The interrupt service routine can write one byte and then test RR0 D2 if more data may be written. The DMA Request in this mode will go inactive after each data write and then go active again until the FIFO is filled. The Transmit Buffer Empty status bit (TBE), RR0 bit D2, is set when the top byte of the FIFO is empty. Note that this IS NOT the reset state.

For applications where the frequency of interrupts is important, the transmit interrupt service routine can be optimized by programming the ESCC to generate the TBE interrupt only when the FIFO is completely empty (WR7' D5=1) and then writing four bytes to fill the FIFO. When WR7' D5=1, only one DMA request is generated (filling the bottom of the FIFO). However, this may be preferred for some applications where the possible reassertion of the DMA request is not desired. The Transmit Buffer Empty status bit (TBE), RR0 bit D2, is set when the top byte of the FIFO is empty. (Note that WR7' D5=1 after a hardware or channel reset).

8-Byte Receive FIFO

The ESCC has an 8-byte receive FIFO with programmable interrupt levels. The receive character available interrupt is generated as selected by WR7' bit D3. The Receive Character Available bit, RR0 D0, is set when at least one byte is available in the top of the FIFO (independent of WR7' D3). It is not necessary to enable the 8-byte FIFO as it is always available. A hardware or channel reset resets the receive shift register and flushes the receive FIFO.

A DMA Request on Receive, if enabled, is generated whenever one byte is available in the receive FIFO independent of WR7' D3. If more than one byte is available in the FIFO, the /Wait/Request pin goes inactive and then goes active again until the FIFO is emptied.

By resetting WR7' D3=0, applications which have a long latency to interrupts can generate the request to read data from the FIFO when one byte is available, and then test the Receive Character Available bit to determine if more data is available.

By setting WR7 D3=1, the ESCC can be programmed to interrupt when the receive FIFO is half full (4 bytes available) and, therefore, allowing the frequency of receive interrupt to be reduced. If WR7' D3 is set, the receive character available interrupt is generated when there are 4 bytes available. Therefore, if the interrupt service routine reads 4 bytes during each routine, the frequency of interrupts is reduced.

If WR7' D3=1 and "Receive Interrupt on All Characters and Special Conditions" is enabled, the receive character available interrupt is generated when four characters are available. However, when a character is detected to have a special condition, a special condition interrupt is generated when the character is loaded into the top four bytes of the FIFO. Therefore, the special condition interrupt service routine should read RR1 before reading the data to determine which byte has the special condition.

Write Register 7' (7 prime)

A new register, WR7', has been added to the ESCC to facilitate the programming of six new features. The format of this register is shown in Figure 12.

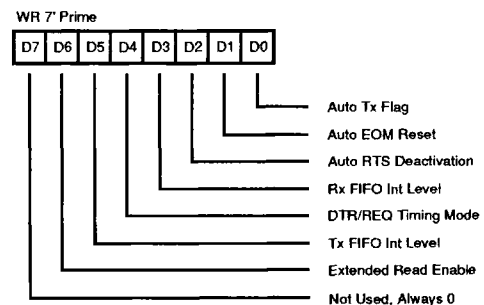

Figure 12. Write Register 7' (7 prime)

WR7' is written to by first setting bit D0 of Write Register 15 (WR15 D0) to one, and then addressing WR7 as normal. All writes to register 7 are to WR7' while WR15 D0 is set. WR15 bit D0 must be reset to 0 to address the sync character register WR7. If bit D6 of WR7' is set, then WR7' can be read by doing a read cycle to RR14. The WR7' features remain enabled until specifically disabled or by a hardware or software reset. Note that bit D5 is set after a reset. All other bits are reset to zero following reset.

Z85230 ENHANCEMENTS (Continued)

For applications which may use either the Zilog Z85C30 or Z85230, these two device types can be identified in software with the following test. Write a 01 hex to Write Register 15. Then read Read Register 15 and if D0 is reset it is a Z85C30 and, if D0 is set it is a Z85230. Note that if the device is Z85C30, a write to WR15 resetting D0 should be done before proceeding. Also, if the device is Z85230, the result in all writes to address seven will be to WR7' until WR15 D0 is reset.

Bit 7. *Not used.* This bit must always be written zero (0).

Bit 6. *Extended Read Enable.* Setting this bit enables the ability to read WR3, WR4, WR5, WR7' and WR10. These registers are read by reading RR9 (WR3), RR4, RR5, RR14 (WR7'), and RR11 (WR10), respectively.

Bit 5. *Transmit FIFO Interrupt Level.* If this bit is set, the transmit buffer empty interrupt is generated when the

transmit FIFO is completely empty. If this bit is reset, the transmit buffer empty interrupt is generated when the top byte of the transmit FIFO is empty. This bit is set following a hardware or channel reset.

In DMA Request on Transmit mode, when using either the /W//REQ or /DTR//REQ pins, the request is asserted when the Tx FIFO is completely empty if WR7' D5 is set. The request is asserted when the top byte of the FIFO is empty if D5 is reset.

Bit 4. */DTR//REQ timing.* If this bit is set and the /DTR//REQ pin is used for Request mode (WR14 D2=1), the deactivation of the /DTR//REQ pin will be identical to the /W//REQ pin as shown in Figure 13. If this bit is reset, the deactivation time is 41cPc.

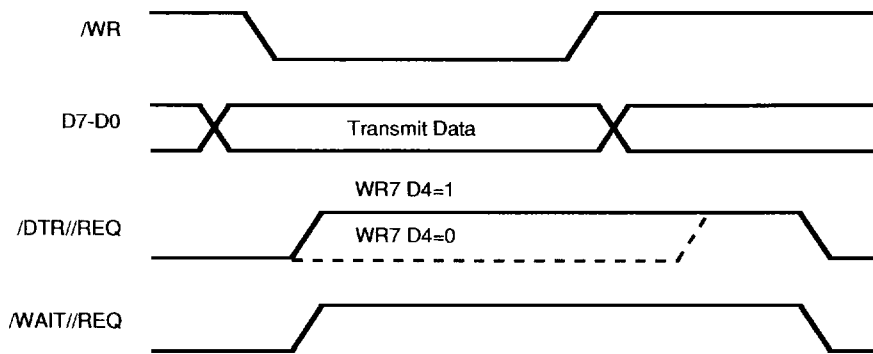

Figure 13. DMA Request on Transmit Deactivation Timing

Bit 3. *Receive FIFO Interrupt Level.* This bit sets the interrupt level of the receive FIFO. If this bit is set, the receive data available bit is asserted when the receive FIFO is half full (4 bytes available). If the RFF bit is reset, the receive data available interrupt is generated when a byte reaches the top of the FIFO. See the description of the 8-byte receive FIFO for more details.

Bit 2. *Automatic /RTS Pin Deassertion.* This bit controls the timing of the deassertion of the /RTS pin in SDLC mode. If this bit is set and WR5 D1 is reset during the transmission of a SDLC frame, the deassertion of the /RTS pin is delayed until the last bit of the closing flag clears the Tx pin. The /RTS pin is pulled high after the rising edge of the transmit clock cycle from the last bit of the closing flag. This implies

that the ESCC should be programmed for "Flag on Underrun" (WR10 D2=0) for the /RTS pin to deassert at the end of the frame. This feature works independently of the programmed transmitter idle state. In synchronous modes other than SDLC, the /RTS pin will immediately follow the state programmed into WR5 D1. When WR7' D2 is reset, the /RTS follows the state of WR5 D1.

Bit 1. *Automatic EOM Reset.* If this bit is set, the ESCC automatically resets the Tx Underrun/EOM latch and pre-sets the transmit CRC generator to its programmed preset state (per values set in WR5 D2 and WR10 D7). Therefore, it is not necessary to issue the Reset Tx Underrun/EOM latch command when this feature is enabled.

Bit 0. Automatic Tx SDLC Flag. If this bit is set, the ESCC will automatically transmit an SDLC flag before transmitting data. This removes the requirement to reset the mark idle bit (WR10 D3) before writing data to the transmitter.

Modified Databus Timing

The ESCC's latching of the databus has been modified to simplify the CPU interface. The Z85C30 AC Timing parameter #29, Write Data to /WR falling minimum, has been changed for the Z85230 to: /WR falling to Write Data Valid maximum. See the AC Timing Characteristic section for the specified time at each clock speed. The databus must be valid no later than 20 ns after the falling edge of /WR regardless of the system (PCLK) clock rate. The databus hold time, spec #30, remains at 0ns.

Historically, the SCC has latched the databus on the falling edge of /WR. However, as many CPUs do not guarantee that the databus is valid when the /WR pin goes low, Zilog has modified the databus timing to allow a maximum delay from the /WR signal going active Low to the latching of the databus.

Complete CRC Reception in SDLC Mode

In SDLC mode, the entire CRC is clocked into the receive FIFO. The ESCC completes clocking in the CRC to allow it to be retransmitted, unaltered, or manipulated in software. In the SCC when the closing flag is recognized, the contents of the receive shift register are immediately transferred to the receive FIFO resulting in the last two bits of the CRC being lost. In the ESCC, it is not necessary to program this feature. When the closing flag is detected, the last two bits of the CRC are clocked into the receive FIFO. In all other synchronous modes, the ESCC does not clock in the last two CRC bits (same as SCC).

TxD Forced High in SDLC with NRZI Encoding When Marking Idle

When the ESCC is programmed for SDLC mode with NRZI data encoding and mark idle (WR10 D6=0, D5=1, D3=1),

the TxD pin is automatically forced high when the transmitter goes to the mark idle state. There are several different ways for the transmitter to go into the idle state. In each of the following cases the TxD pin is forced high when the mark idle condition is reached: data, CRC, flag and idle; data, flag and idle; data, abort (on underrun) and idle; data, abort (command) and idle; idle flag and command to idle mark. The force high feature is disabled when the mark idle bit is reset.

This feature is used in combination with the automatic SDLC opening flag transmission feature, WR7' D0=1, to assure that data packets are properly formatted. Therefore, when these features are used together, it is not necessary for the CPU to issue any commands when using the force idle mode in combination with NRZI data encoding. If WR7' D0 is reset, like in the SCC, it is necessary to reset the mark idle bit (WR10 D3) to enable flag transmission before an SDLC packet is transmitted.

Improved Transmit Interrupt Handling in Synchronous Modes

The ESCC latches the Transmit Buffer Empty (TBE) interrupt due to the CRC being loaded to the transmit shift register even if the TBE interrupt, due at the last data byte, has not yet been reset. Therefore, the end of a synchronous frame is guaranteed to generate two TBE interrupts even if a reset transmit buffer interrupt command for the data created interrupt is issued after (time "A" in Figure 14) the CRC interrupt had occurred. In this case, two reset TBE commands are required. The TxIP is latched if the EOM latch has been reset before the end of the frame.

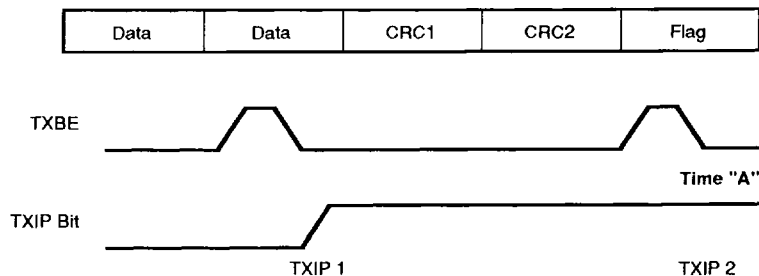

Figure 14. TxIP Latching

NEW FEATURE DESCRIPTION (Continued)

DPLL Counter Tx Clock Source

When DPLL output is selected as the transmit clock source, the DPLL counter output is the DPLL source clock divided by the appropriate divisor for the programmed data encoding format. Therefore, in FM mode (FM0 or FM1), the DPLL counter output is the input frequency divided by 16.

In NRZI mode, the DPLL counter frequency is the input divided by 32. This feature provides a jitter-free output and replaces the DPLL transmit clock output being available as the transmit clock source. This has no effect on the use of the DPLL as the receive clock source (Figure 15).

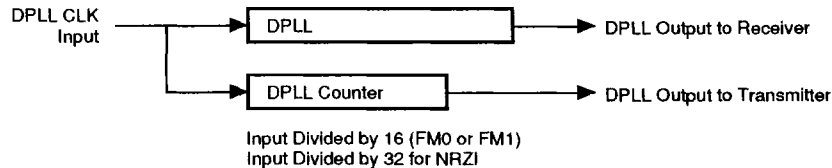

Figure 15. DPLL Outputs

Read Register 0 Status Latched During Read Cycle

The contents of Read Register 0, RR0, are latched during a read to this register. The ESCC prevents the contents of RR0 to change while the Read cycle is active. The SCC allows the status of RR0 to change while reading the register and, therefore, it is necessary to read RR0 twice to detect changes that otherwise may be missed. The contents of RR0 are updated after the rising edge of /RD.

Software Interrupt Acknowledge

The Z85230 interrupt acknowledge cycle can be initiated through software. If Write Register 9 (WR9) bit D5 is set, reading register 2 (RR2) results in an interrupt acknowledge cycle to be executed internally. Like a hardware INTACK cycle, a software acknowledge causes the INT pin to return high, the IEO pin to go Low and set the IUS latch for the highest priority interrupt pending.

Similar to when the hardware INTACK signal can be used, a software acknowledge cycle requires that a Reset Highest IUS command be issued in the interrupt service routine. Whenever an interrupt acknowledge cycle is used, hardware or software, a reset highest IUS command is required. If RR2 is read from channel A, the unmodified vector is returned. If RR2 is read from channel B, then the vector is modified to indicate the source of the interrupt. The Vector Includes Status (VIS) and No Vector (NV) bits in WR9 are ignored when bit D5 is set to 1.

When the INTACK and IEL pins are not being used, they should be pulled up to V_{CC} through a resistor (10k Ohm typical).

Fast SDLC Transmit Data Interrupt Response

To more easily facilitate the transmission of back-to-back SDLC frames with a single shared flag between frames, the ESCC allows data for a second frame to be written to the transmit FIFO after the Tx Underrun/EOM interrupt has occurred. This allows application software more time to write the data to the transmitter while allowing the current frame to be properly concluded with CRC and flag. The SCC historically has required that data not be written to the transmitter until a transmit buffer empty interrupt was generated after the CRC has completed transmission. If data is written to the transmit FIFO after the Transmit Underrun/EOM interrupt and before the transmit buffer empty interrupt, the Automatic EOM Reset feature should be enabled (WR7' D1=1). Consequently, the commands "Reset Tx/Underrun EOM" latch and "Reset Tx CRC Generator" should not be used.

SDLC FIFO Frame Status FIFO Enhancement

When used with a DMA controller, the Z85230 SDLC Frame Status FIFO enhancement maximizes the ESCC's ability to receive high speed, back-to-back SDLC messages. It minimizes frame overruns due to CPU latencies in responding to interrupts. Additional logic was added to the industry standard SCC consisting of a 10-bit deep by 19-bit wide status FIFO, 14-bit receive byte counter, and control logic as shown in Figure 16. The 10 x 19 bits status FIFO is separate from the 8-byte receive data FIFO.

When the enhancement is enabled, the status in Read Register 1 (RR1) and byte count for the SDLC frame are stored in the 10 x 19-bit status FIFO. This allows the DMA controller to transfer the next frame into memory while the CPU verifies that the message was properly received.

Summarizing the operation; data is received, assembled, and loaded into the 8-byte FIFO before being transferred to memory by the DMA controller. When a flag is received at the end of an SDLC frame, the frame byte count from the 14-bit counter and five status bits are loaded into the status FIFO for verification by the CPU. The CRC checker is automatically reset in preparation for the next frame which can begin immediately. Since the byte count and status are saved for each frame, the message integrity is verified at a later time. Status information for up to 10 frames is stored before a status FIFO overrun can occur.

If a frame is terminated with an ABORT, the byte count and status will be loaded to the status FIFO and the counter reset for the next frame.

FIFO Detail. For a better understanding of details of the FIFO operation, refer to the block diagram in Figure 16.

Enable/Disable. This FIFO is implemented so that it is enabled when WR15, bit D2, is set and the ESCC is in the SDLC/HIDI.C mode. Otherwise, the status register contents bypass the FIFO and go directly to the bus interface (the FIFO pointer logic is reset either when disabled or via a channel or power-on reset). When the FIFO mode is disabled, the ESCC is completely downward compatible with the NMOS Z8530. The FIFO mode is disabled on power-up (WR15 D2 is set to 0 on reset). The effects of backward compatibility on the register set are that RR4 is an image of RR0, RR5 is an image of RR1, RR6 is an image of RR2 and RR7 is an image of RR3. For details on the added registers, refer to Figure 18. The status of the FIFO Enable signal is obtained by reading RR15, bit D2. If the FIFO is enabled, the bit will be set to 1; otherwise, it will be reset.

Read Operation. When WR15 bit D2 is set and the FIFO is not empty, the next read to status register RR1 or the additional registers RR7 and RR6, are from the FIFO. Reading status register RR1 causes one location of the FIFO to be emptied, so status is read after reading the byte count, otherwise the count is incorrect. Before the FIFO underflows, it is disabled. In this case, the multiplexer is switched to allow status to read directly from the status register. Reads from RR7 and RR6 contain bits that are undefined. Bit D6 of RR7 (FIFO Data Available) is used to determine if status data is coming from the FIFO or directly from the status register, since it is set to 1 whenever the FIFO is not empty.

Since not all status bits are stored in the FIFO, the All Sent, Parity, and EOF bits bypass the FIFO. The status bits sent through the FIFO are Residue Bits (3), Overrun, and CRC Error.

The sequence for proper operation of the byte count and FIFO logic is to read the registers in the following order: RR7, RR6, and RR1 (reading RR6 is optional). Additional logic prevents the FIFO from being emptied by multiple reads from RR1. The read from RR7 latches the FIFO empty/full status bit (D6) and steers the status multiplexer to read from the ESCC megacell instead of the status FIFO (since the status FIFO is empty). The read from RR1 allows an entry to be read from the FIFO (if the FIFO was empty, logic was added to prevent a FIFO underflow condition).

Write Operation. When the end of an SDLC frame (EOF) has been received and the FIFO is enabled, the contents of the status and byte-count registers are loaded into the FIFO. The EOF signal is used to increment the FIFO. If the FIFO overflows, the RR7 bit D7 (FIFO Overflow) is set to indicate the overflow. This bit and the FIFO control logic is reset by disabling and re-enabling the FIFO control bit (WR15 bit D2). For details of FIFO control timing during an SDLC frame, refer to Figure 17.

SDLC Status FIFO Anti-Lock Feature. When the Frame Status FIFO is enabled and the ESCC is programmed for "Special Receive Condition Only" (WR1 D4=D3=1), the data FIFO is not locked when a character with End of Frame status is read (Figure 16). When a character with the EOF status is at the top of the FIFO, an interrupt with a vector for receive data is generated. The command "Reset Highest IUS" must be issued at the end of the interrupt service routine regardless if an interrupt acknowledge cycle had been executed (hardware or software). This allows a DMA to complete transfer of the received frame to memory and then interrupt the CPU that a frame has been completed without locking the FIFO. Since in the "Receive Interrupt on Special Condition Only" mode the interrupt vector for receive data is not used, it is used to indicate that the last byte of a frame has been read out the receive FIFO. Reading the frame status (CRC, byte count and other status stored in the status FIFO) to determine EOF is not required.

When a character with a special receive condition other than EOF is received (receiver overrun, or parity), a special receive condition interrupt is generated after the character is read from the FIFO and the receive FIFO is locked until the "Error Reset" command is issued.

NEW FEATURE DESCRIPTION (Continued)

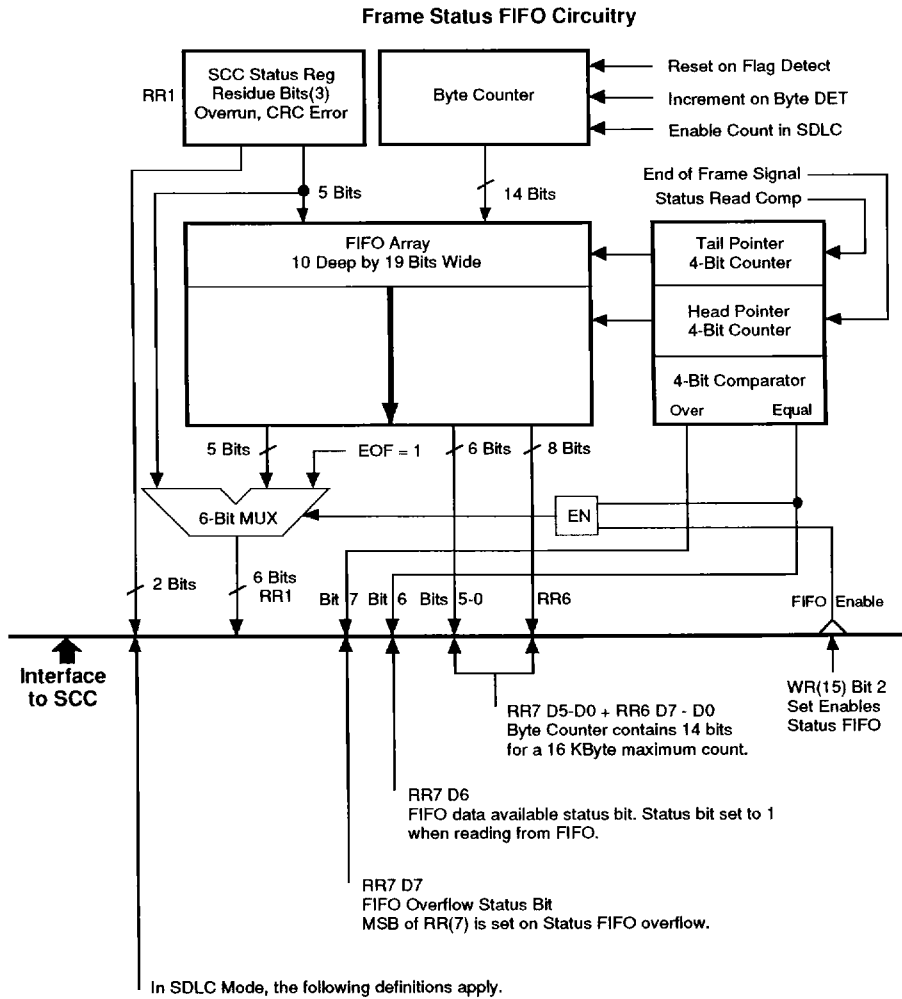

Figure 16. SDLC Frame Status FIFO

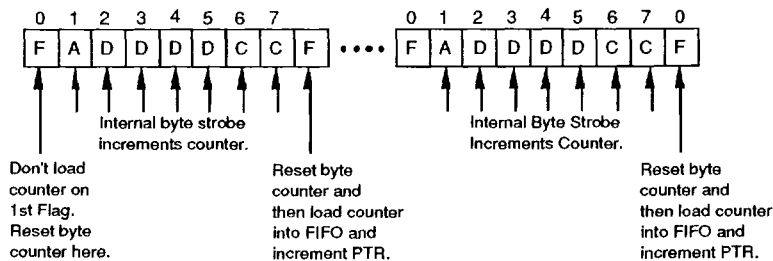

Figure 17. SDLC Byte Counting Detail

PROGRAMMING

The FSCC contains write registers in each channel that are programmed by the system separately to configure the functional uniqueness of the channels.

In the ESCC, the data registers are directly addressed by selecting a High on the D//C pin. With all other registers (with the exception of WR0 and RR0), programming the write registers requires two write operations and reading the read registers requires both a write and a read operation. The first write is to WR0 and contains three bits that point to the selected register. The second write is the actual control word for the selected register, and if the second operation is read, the selected read register is accessed. All of the ESCC registers, including the data registers, may be accessed in this fashion. The pointer bits are automatically cleared after the read or write operation so that WR0 (or RR0) is addressed again.

Initialization. The system program first issues a series of commands to initialize the basic mode of operation. This is followed by other commands to qualify conditions within the selected mode. For example, in the Asynchronous mode, character length, clock rate, number of stop bits, and even or odd parity should be set first. Then the interrupt mode is set, and finally, the receiver and transmitter are enabled.

Write Registers. The ESCC contains 16 write registers (17 counting the transmit buffer) in each channel. These write registers are programmed separately to configure the functional "personality" of the channels. There are two registers (WR2 and WR9) shared by the two channels that are accessed through either of them. WR2 contains the interrupt vector for both channels, while WR9 contains the interrupt control bits and reset commands. A new register, WR7', was added to the ESCC and may be written to if WR15 D0 is set. Figure 18 shows the format of each write register.

Read Registers. The ESCC contains ten read registers (eleven, counting the receive buffer (RR8) in each channel). Four of these may be read to obtain status information (RR0, RR1, RR10, and RR15). Two registers (RR12 and RR13) are read to learn the baud rate generator time constant. RR2 contains either the unmodified interrupt vector (Channel A) or the vector modified by status information (Channel B). RR3 contains the Interrupt Pending (IP) bits (Channel A only). RR6 and RR7 contain the information in the SDLC Frame Status FIFO, but is only read when WR15 D2 is set. If WR7' D6 is set, Write Registers WR3, WR4, WR5, WR7', and WR10 can be read as RR9, RR4, RR5, and RR14, respectively. Figure 19 shows the format of each Read register.

CONTROL REGISTERS

Write Register 0 (non-multiplexed bus mode)

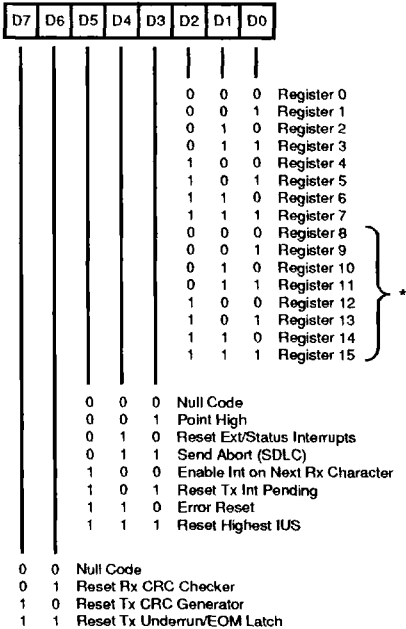

* With Point High Command

Write Register 2

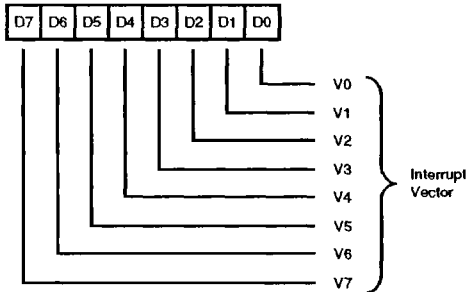

Write Register 3

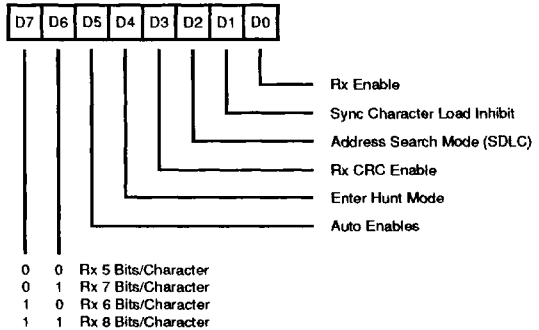

Write Register 1

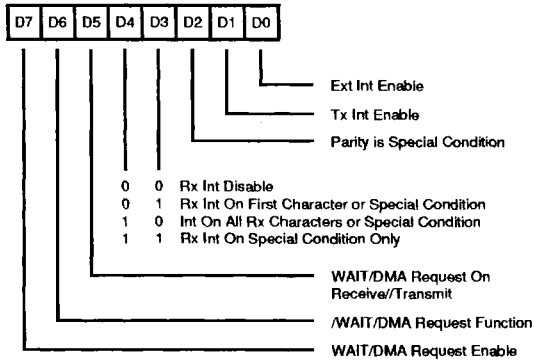

Write Register 4

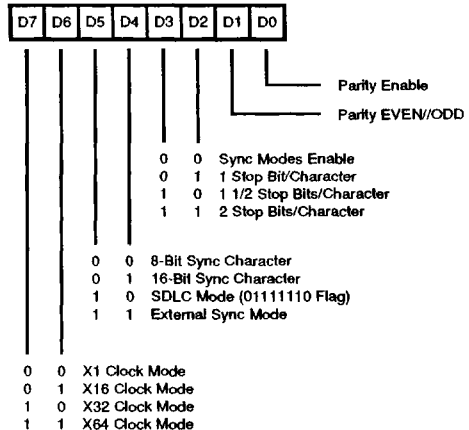

Figure 18. Write Register Bit Functions

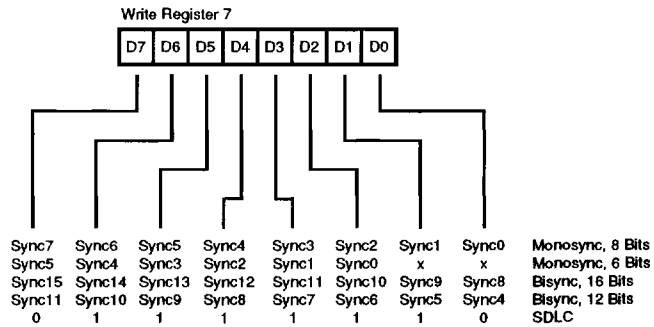
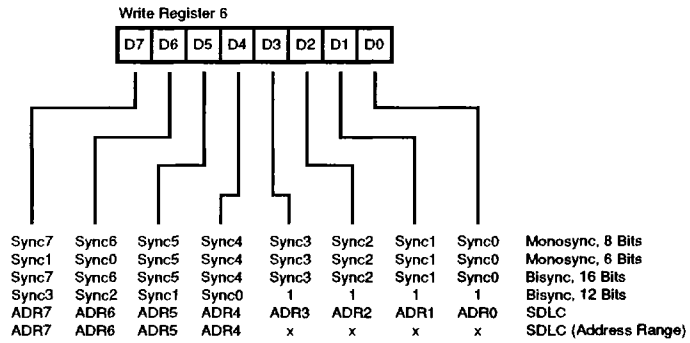
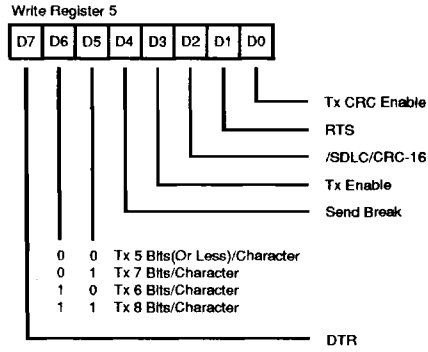
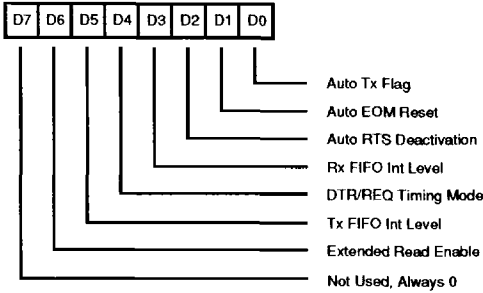

Figure 18. Write Register Bit Functions (Continued)

CONTROL REGISTERS (Continued)

WR 7 Prime



Write Register 10

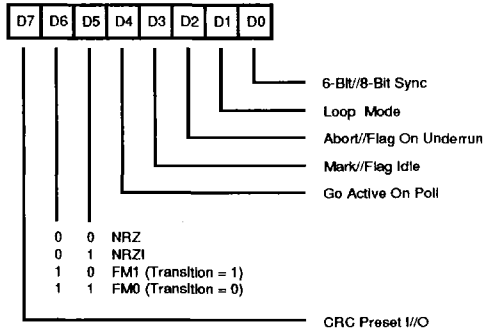

Write Register 9

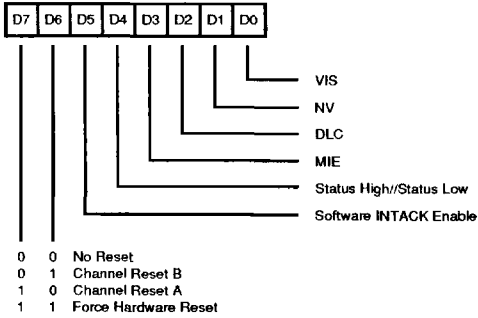

Write Register 11

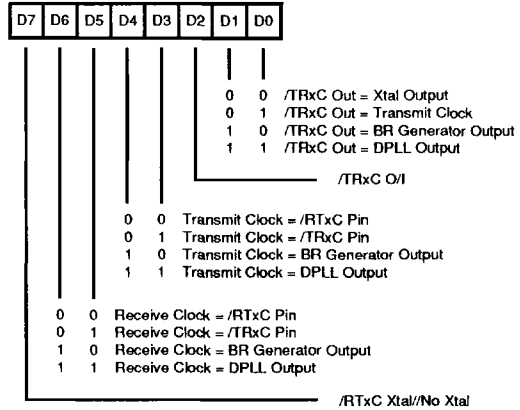
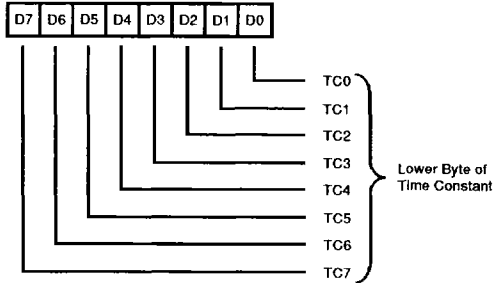
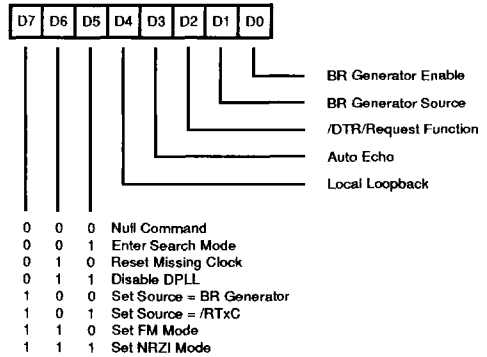

Figure 18. Write Register Bit Functions (Continued)

Write Register 12



Write Register 14



Write Register 13

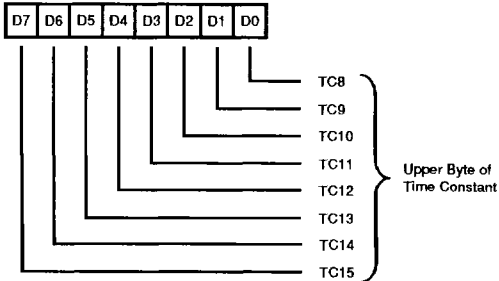

Write Register 15

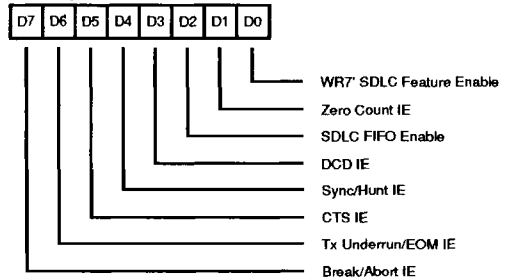
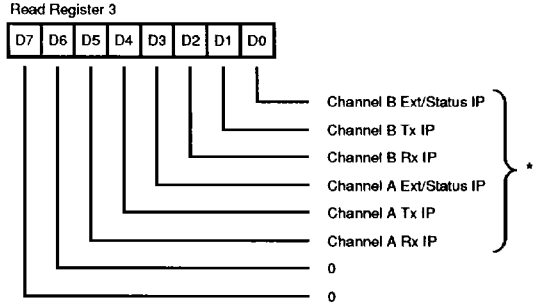
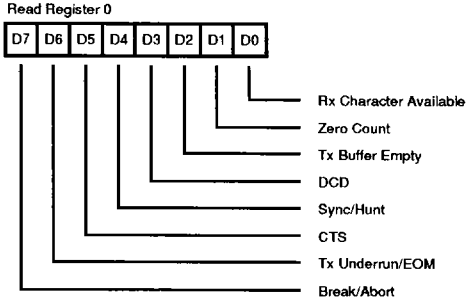
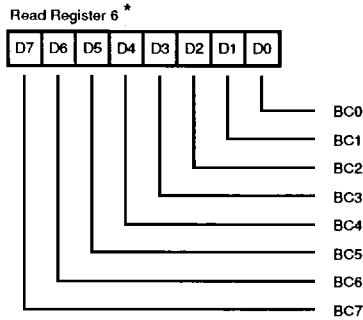
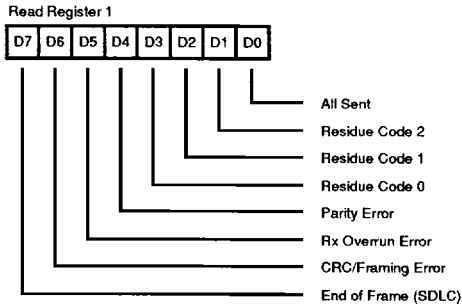

Figure 18. Write Register Bit Functions (Continued)

CONTROL REGISTERS (Continued)



* Always 0 In B Channel



* Can only be accessed if the SDLC FIFO enhancement is enabled (WR15 bit D2 set to 1)

SDLC FIFO Status and Byte Count (LSB)

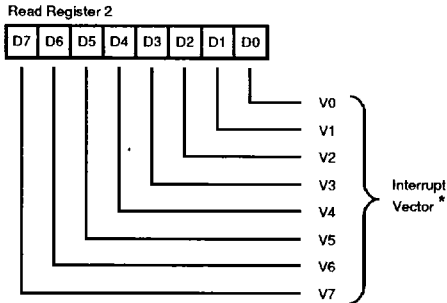

* Modified in B Channel

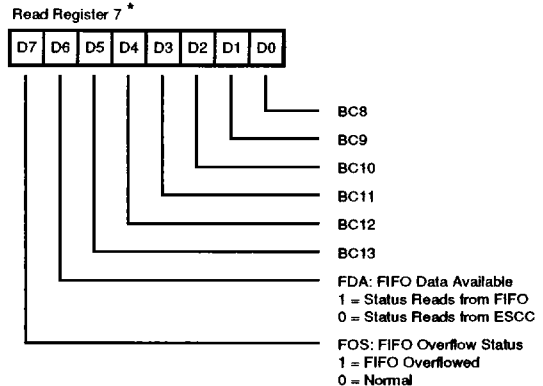

* Can only be accessed if the SDLC FIFO enhancement is enabled (WR15 bit D2 set to 1)

SDLC FIFO Status and Byte Count (MSB)

Figure 19. Read Register Bit Functions

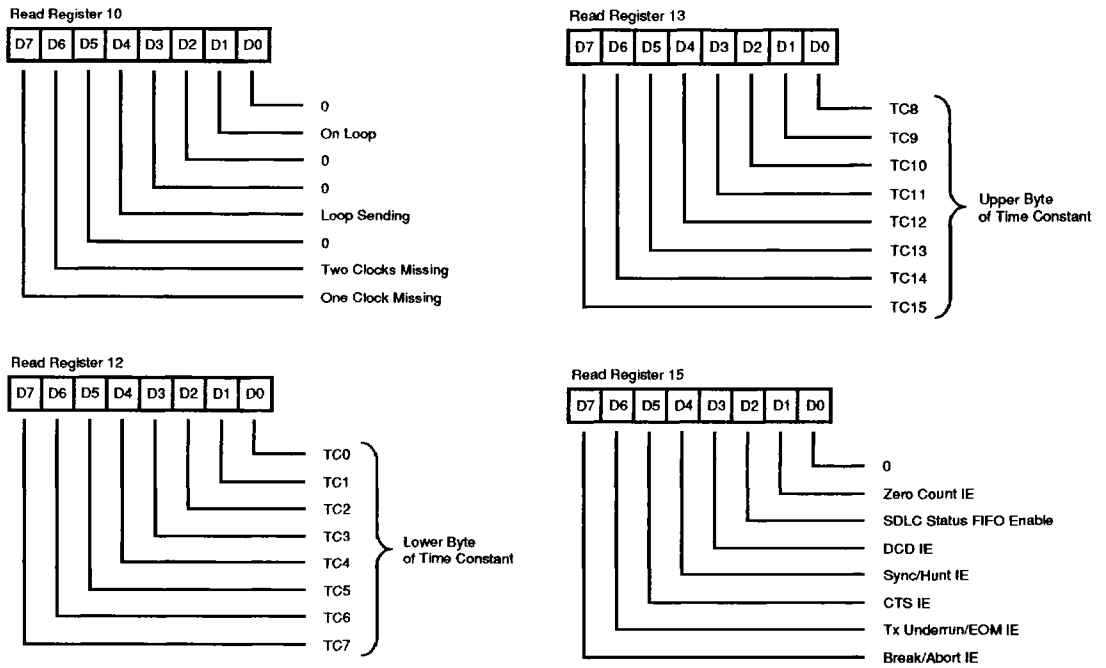

Figure 19. Read Register Bit Functions (Continued)

Z85230 TIMING

The ESCC generates internal control signals from the $/\text{WR}$ and $/\text{RD}$ that are related to PCLK . Since PCLK has no phase relationship with $/\text{WR}$ and $/\text{RD}$, the circuitry generating the internal control signals provides time for metastable conditions to disappear. This gives rise to a recovery time related to PCLK . The recovery time applies only between bus transactions involving the ESCC. The recovery time required for proper operation is specified from the falling edge of $/\text{WR}$ or $/\text{RD}$ in the first transaction involving the ESCC to the falling edge of $/\text{WR}$ or $/\text{RD}$ in the second

transaction involving the ESCC. This time must be at least 4 PCLK s regardless of which register or channel is being accessed.

Read Cycle Timing. Figure 20 illustrates Read cycle timing. Addresses on A/B and D/C and the status on $/\text{INTACK}$ must remain stable throughout the cycle. If $/\text{CE}$ falls after $/\text{RD}$ falls, or if it rises before $/\text{RD}$ rises, the effective $/\text{RD}$ is shortened.

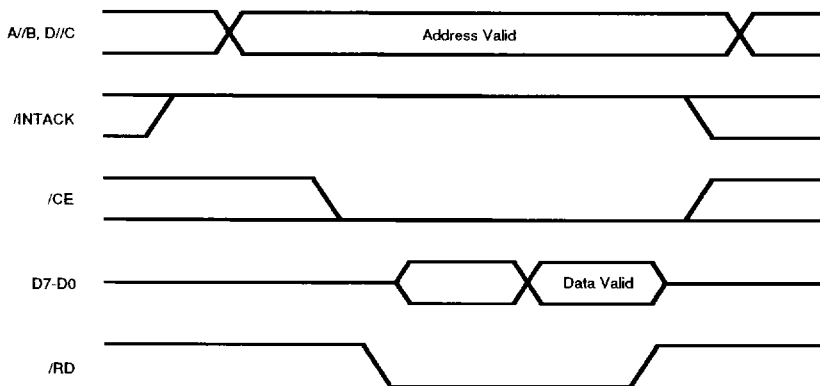

Figure 20. Read Cycle Timing

Write Cycle Timing. Figure 21 illustrates Write cycle timing. Addresses on A/B and D/C and the status on $/\text{INTACK}$ must remain stable throughout the cycle. If $/\text{CE}$ falls after $/\text{WR}$ falls, or if it rises before $/\text{WR}$ rises, the effective $/\text{WR}$ is shortened. Because many popular CPUs do not guaran-

tee that the databus is valid when $/\text{WR}$ is driven Low, the databus timing requirements of the ESCC have been modified so that the databus does not have to be valid when the $/\text{WR}$ pin goes Low. See AC Characteristic #29 for details.

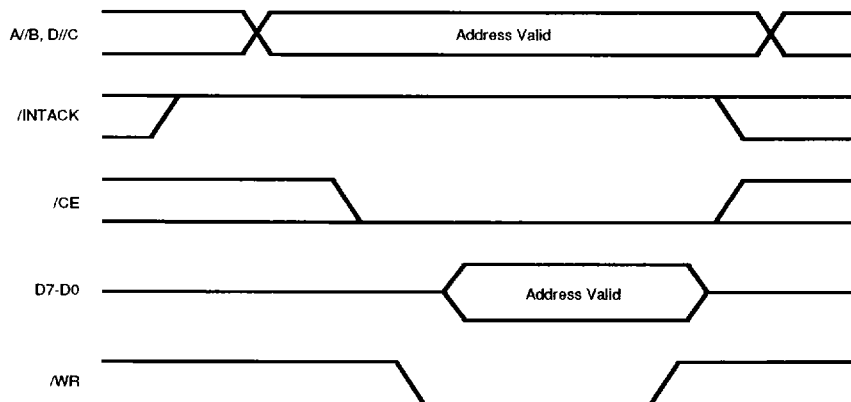

Figure 21. Write Cycle Timing

Interrupt Acknowledge Cycle Timing. Figure 22 illustrates Interrupt Acknowledge cycle timing. Between the time /INTACK goes Low and the falling edge of /RD, the internal and external IEI/IEO daisy chains settle. If there is an interrupt pending in the ESCC and IEI is High when /RD falls, the Acknowledge cycle is intended for the ESCC. In this case, the LSCC may be programmed to respond to /RD Low by placing its interrupt vector on D7-D0. It then

sets the appropriate Interrupt-Under-Service latch internally. If the external daisy chain is not used, then AC parameter #38 is required to settle the interrupt priority daisy chain internal to the ESCC. If the external daisy chain is used, the user should follow the equation in AC Characteristics Note 5 for calculating the required daisy-chain settle time.

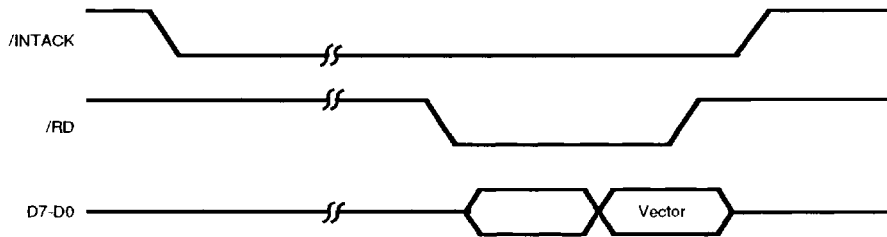

Figure 22. Interrupt Acknowledge Cycle Timing

ABSOLUTE MAXIMUM RATINGS

V_{cc} Supply Voltage range	-0.3V to +7.0V
Voltages on all pins with respect to GND	-0.3V to V_{cc} +0.3V
Operating Ambient Temperature	-55°C to +125°C
Storage Temperature	-65°C to +150°C

Stresses greater than those listed under Absolute Maximum Ratings may cause permanent damage to the device. This is a stress rating only; operation of the device at any condition above those indicated in the operational sections of these specifications is not implied. Exposure to absolute maximum rating conditions for extended periods may affect device reliability.

STANDARD TEST CONDITIONS

The DC Characteristics and capacitance sections below apply for the following standard test conditions, unless otherwise noted. All voltages are referenced to GND. Positive current flows into the referenced pin.

Standard conditions are as follows:

- $+4.50\text{ V} \leq V_{cc} \leq +5.50\text{ V}$
- $\text{GND} = 0\text{ V}$
- -55°C to $+125^\circ\text{C}$

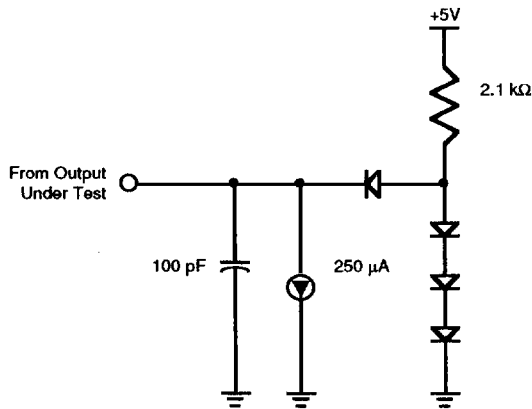

Figure 23. Standard Test Load

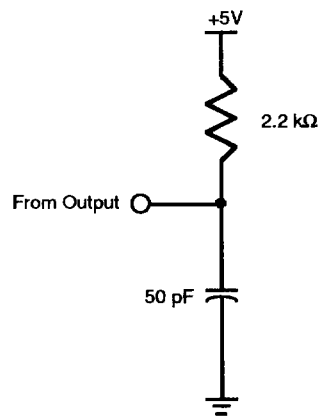

Figure 24. Open-Drain Test Load

CAPACITANCE

Symbol	Parameter	Min	Max	Unit	Test Condition
C_{IN}	Input Capacitance		10	pF	Unmeasured pins returned to Ground.
C_{OUT}	Output Capacitance		15	pF	
C_{VO}	Bidirectional Capacitance		20	pF	

Note:

f = 1 MHz, over specified temperature range.

MISCELLANEOUS

Gate Count - 11,000

DC CHARACTERISTICS

Z85230

Symbol	Parameter	Min	Typ	Max	Unit	Condition
V_{IH}	Input High Voltage	2.2		$V_{CC}+0.3$	V	
V_{IL}	Input Low Voltage	-0.3		0.8	V	
V_{OH1}	Output High Voltage	2.4			V	$I_{OH} = -1.6mA$
V_{OH2}	Output High Voltage	$V_{CC}-0.8$			V	$I_{OH} = -250\mu A$
V_{OL}	Output Low Voltage			0.4	V	$I_{OL} = 2.0mA$
I_{IL}	Input Leakage			± 10.0	μA	$0.2 \leq V_{IN} < V_{CC} - 0.2V$
I_{OL}	Output Leakage			± 10.0	μA	$0.2 \leq V_{OUT} < V_{CC} - 0.2V$
I_{CC1}	V_{CC} Supply Current		6	15 (8.5 MHz)	mA	
			8	18 (10 MHz)	mA	$V_{CC}=5V$ $V_{IH}=4.8$ $V_{IL}=0.2V$
			12	22 (16 MHz)	mA	Crystal Oscillators off
$I_{CC(OSC)}$	Crystal OSC Current		6		mA	Current for each osc. in addition to I_{CC1}

Notes:

[1] $V_{CC} = 5V \pm 10\%$ unless otherwise specified, over specified temperature range.

[2] Typical I_{CC} was measured with oscillator off.

[3] No $I_{CC(OSC)}$ max is specified due to dependency on the external circuit.

AC CHARACTERISTICS
Z85230 Timing Diagrams

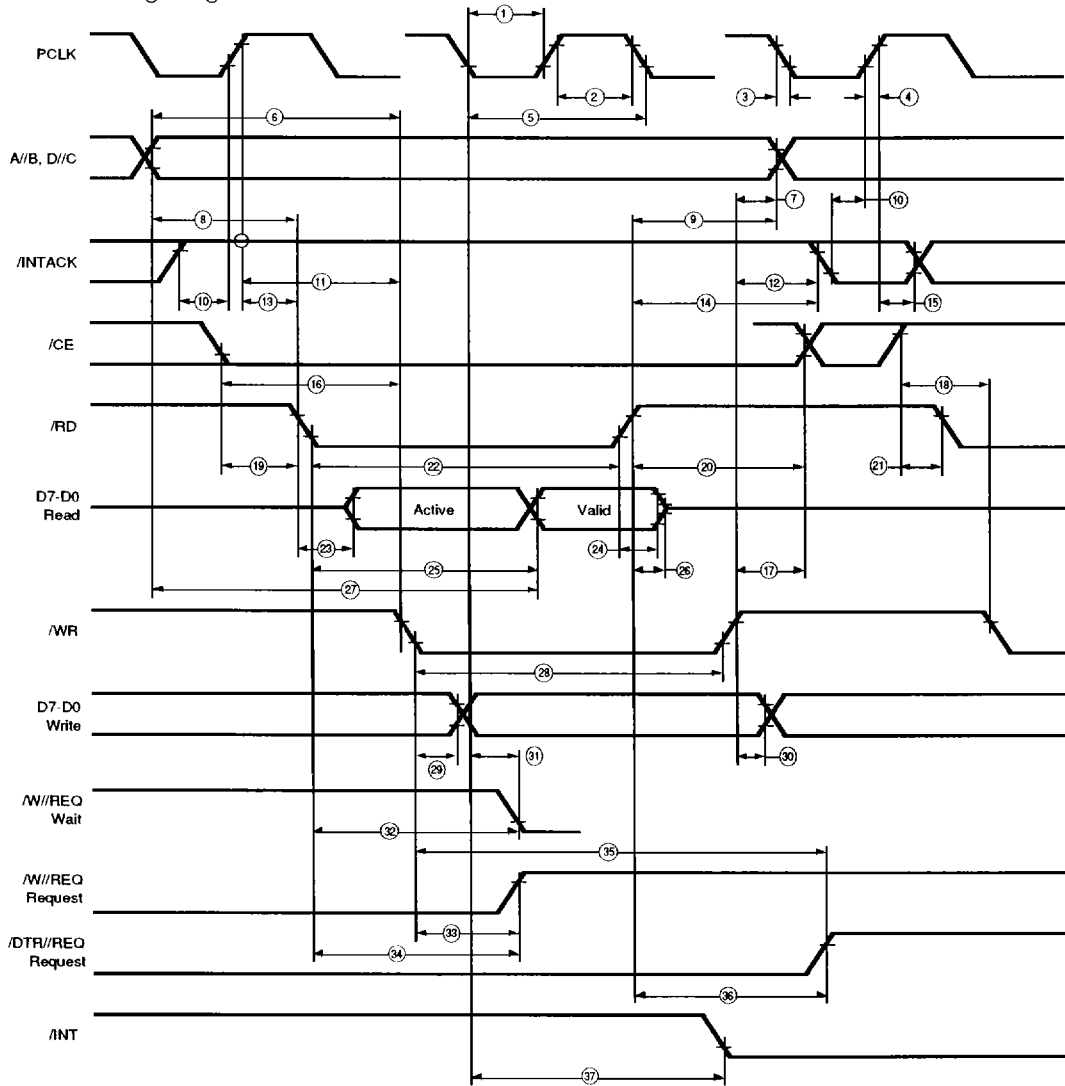

Figure 25. Read and Write Timing Diagram

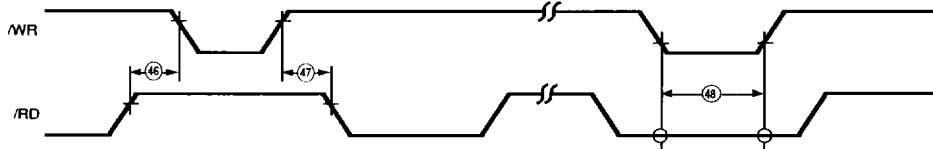

Figure 26. Reset Timing Diagram

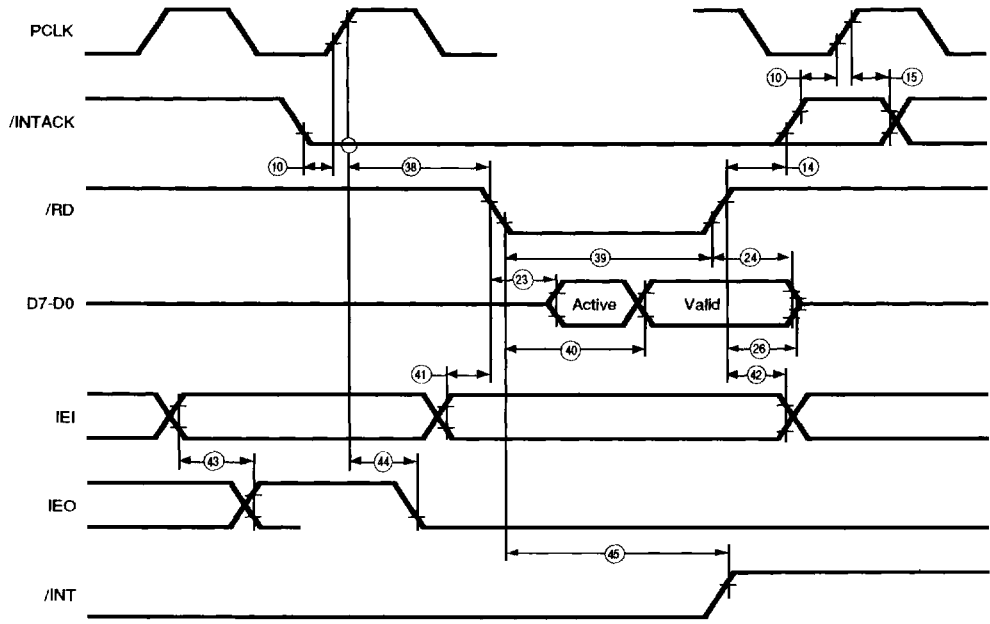

Figure 27. Interrupt Acknowledge Timing Diagram

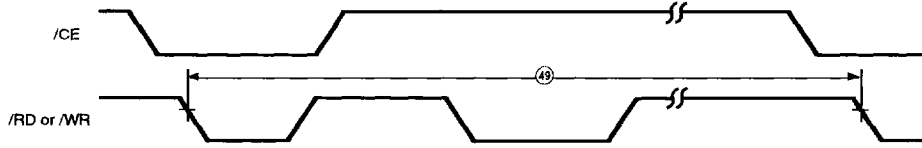

Figure 28. Cycle Timing Diagram

AC CHARACTERISTICS

Z85230 Read and Write Timing Table

No	Symbol	Parameter	8 MHz		10 MHz		16 MHz	
			Min	Max	Min	Max	Min	Max
1	TwPCI	PCLK Low Width	50	1000	40	1000	26	1000
2	TwPCh	PCLK High Width	50	1000	40	1000	26	1000
3	TfPC	PCLK Fall Time		10		10		5
4	TrPC	PCLK Rise Time		10		10		5
5	TcPC	PCLK Cycle Time	125	2000	100	2000	61	2000
6	TsA(WR)	Address to /WR Fall Setup Time	70		50		35	
7	ThA(WR)	Address to /WR Rise Hold Time	0		0		0	
8	TsA(RD)	Address to /RD Fall Setup Time	70		50		35	
9	ThA(RD)	Address to /RD Rise Hold Time	0		0		0	
10	TsIA(PC)	/INTACK to PCLK Rise Setup Time	20		20		15	

AC CHARACTERISTICS

Z85230 Read and Write Timing Table

No	Symbol	Parameter	8 MHz		10 MHz		16 MHz		Notes
			Min	Max	Min	Max	Min	Max	
11	TsIAi(WR)	/INTACK To /WR Fall Setup Time	145		120		70		[1]
12	ThIA(WR)	/INTACK To /WR Rise Hold Time	0		0		0		
13	TsIAi(RD)	/INTACK To /RD Fall Setup Time	145		120		70		[1]
14	ThIA(RD)	/INTACK To /RD Rise Hold Time	0		0		0		
15	ThIA(PC)	/INTACK To PCLK Rise Hold Time	40		30		15		
16	TsCEi(WR)	/CE Low To /WR Fall Setup Time	0		0		0		
17	ThCE(WR)	/CE To /WR Rise Hold Time	0		0		0		
18	TsCEh(WR)	/CE High To /WR Fall Setup Time	60		50		30		
19	TsCEi(RD)	/CE Low To /RD Fall Setup Time	0		0		0		[1]
20	ThCE(RD)	/CE To /RD Rise Hold Time	0		0		0		[1]
21	TsCEh(RD)	/CE High To /RD Fall Setup Time	60		50		30		[1]
22	TwRDI	/RD Low Width	150		125		70		[1]
23	TdRD(DRA)	/RD Fall To Read Data Active Delay	0		0		0		
24	TdRDr(DR)	/RD Rise To Data Not Valid Delay	0		0		0		
25	TdRDI(DR)	/RD Fall To Read Data Valid Delay		140		120		70	
26	TdRD(DRz)	/RD Rise To Read Data Float Delay		40		35		30	
27	TdA(DR)	Addr To Read Data Valid Delay		220		160		100	
28	TwWRI	/WR Low Width	150		125		75		
29	TdWR(DW)	/WR Fall To Write Data Valid Delay		20		20		20	
30	ThDW(WR)	Write Data To /WR Rise Hold Time	0		0		0		
31	TdWR(W)	/WR Fall To Wait Valid Delay		170		100		50	[4]
32	TdRD(W)	/RD Fall To Wait Valid Delay		170		100		50	[4]
33	TdWRr(REQ)	/WR Fall To /W//REQ Not Valid Delay		170		120		70	
34	TdRDl(REQ)	/RD Fall To /W//REQ Not Valid Delay		170		120		70	[6]
35a	TdWRr(REQ)	/WR Fall To /DTR//REQ Not Valid		4TcPc		4TcPc		4TcPc	
35b	TdWRr(REQ)	/WR Fall To /DTR//REQ Not Valid		120		100		70	[6]
36	TdRDr(REQ)	/RD Rise To /DTR//REQ Not Valid Delay		NA		NA		NA	
37	TdPC(INT)	PCLK Fall To /INT Valid Delay		500		320		175	
38	TdIAi(RD)	/INTACK To /RD Fall (Ack) Delay	150		90		50		[5]
39	TwRDA	/RD (Acknowledge) Width	150		125		75		
40	TdRDA(DR)	/RD Fall(Ack) To Read Data Valid Delay		140		120		70	
41	TsIEi(RDA)	IEI To /RD Fall (Ack) Setup Time	95		80		50		
42	ThIEi(RDA)	IEI To /RD Rise (Ack) Hold Time	0		0		0		
43	TdIEi(IEO)	IEI To IEO Delay Time		95		80		45	
44	TdPC(IEO)	PCLK Rise To IEO Delay		200		175		80	
45	TdRDA(INT)	/RD Fall To /INT Inactive Delay		450		320		200	[4]
46	TdRD(WRQ)	/RD Rise To /WR Fall Delay For No Reset	15		15		10		
47	TdWRQ(RD)	/WR Rise To /RD Fall Delay For No Reset	15		15		10		
48	TwRES	/WR And /RD Low For Reset	150		100		75		
49	Trc	Valid Access Recovery Time	4TcPc		4TcPc		4TcPc		[3]

Notes:

- [1] Parameter does not apply to Interrupt Acknowledge transactions.
- [3] Parameter applies only between transactions involving the ESCC.
- [4] Open-drain output, measured with open-drain test load.
- [5] Parameter is system dependent. For any ESCC in the daisy chain, TdIAi(RD) must be greater than the sum of TdPC(IEO) for the highest priority device in the daisy chain. TsIEi(RDA) for the ESCC and TdIEi(IEO) for each device separating them in the daisy chain.
- [6] Parameter applies to enhanced Request mode only (WR7' D4= 1).

AC CHARACTERISTICS
Z85230 General Timing Diagram

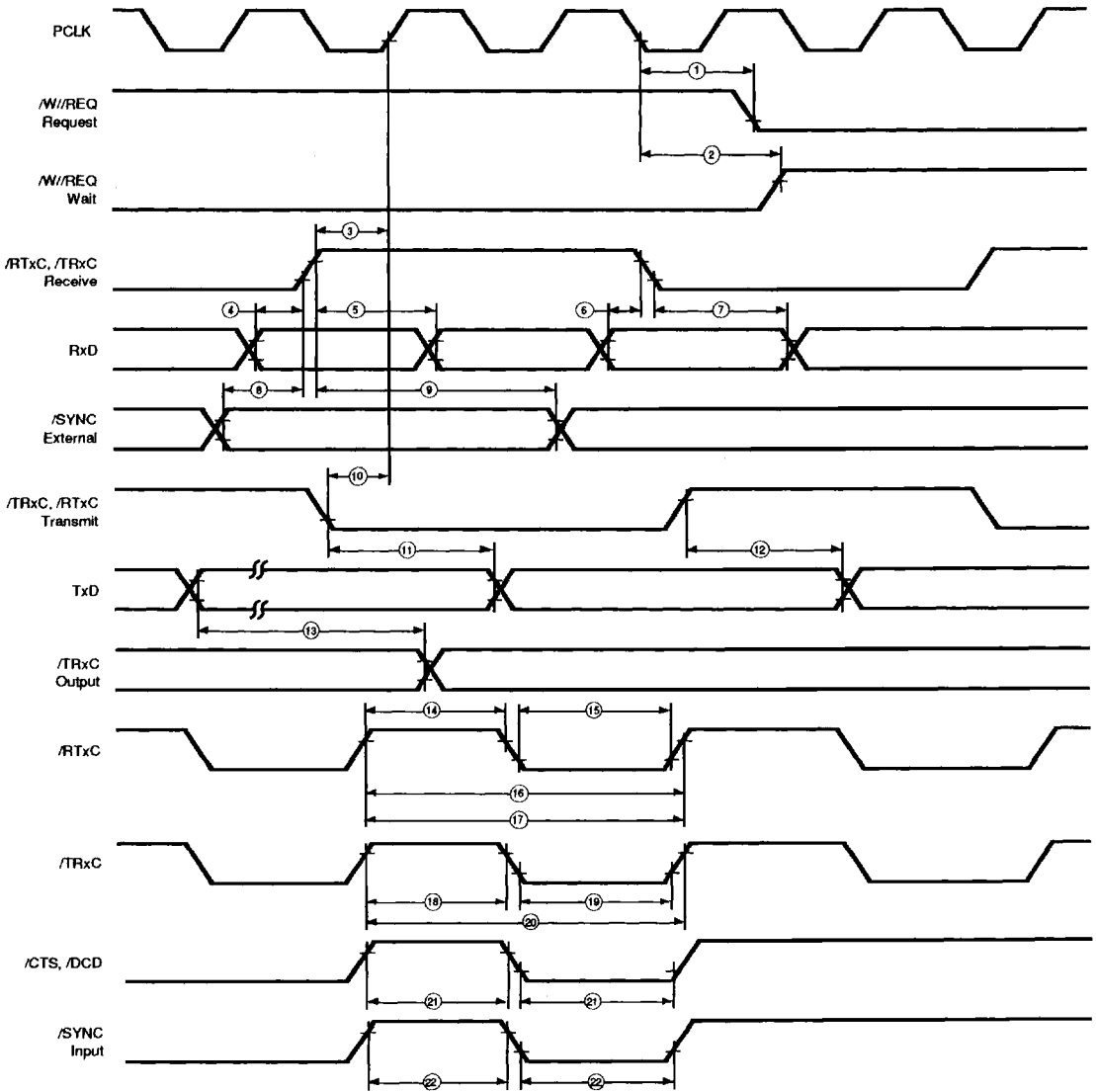

Figure 29. General Timing Diagram

AC CHARACTERISTICS

Z85230 General Timing Table

No	Symbol	Parameter	8.5 MHz		10 MHz		16 MHz		Notes
			Min	Max	Min	Max	Min	Max	
1	TdPC(REQ)	/PCLK to W/REQ Valid		250		150		80	
2	TdPC(W)	/PCLK to Wait Inactive		350		250		180	
3	TsRXC(PC)	/RxC to /PCLK Setup Time	NA		NA		NA		[1,4]
4	TsRXD(RxCr)	RxD to /RxC Setup Time	0		0		0		[1]
5	ThRXD(RxCr)	RxD to /RXC Hold Time	150		125		50		[1]
6	TsRXD(RxCf)	RxD to /RXC Setup Time	0		0		0		[1,5]
7	ThRXD(RxCf)	RxD to /RXC Hold Time	150		125		50		[1,5]
8	TsSY(RXC)	/SYNC to /RxC Setup Time	-200		-150		-100		[1]
9	ThSY(RXC)	/SYNC to/RXC Hold Time	5TcPc		5TcPc		5TcPc		[1]
10	TsTXC(PC)	/TxC to /PCLK Setup Time	NA		NA		NA		[2,4]
11	TdTXC(TXD)	/TxC to TxD Delay		190		150		80	[2]
12	TdTxCr(TXD)	/TxC to TxD Delay		190		150		80	[2,5]
13	TdTXD(TRX)	TxD to TRxC Delay		200		140		80	
14	TwRTXh	RTxC High Width	130		120		80		[6]
15	TwRTXl	TRxC Low Width	130		120		80		[6]
16a	TcRTX	RTxC Cycle Time	472		400		244		[6,7]
16b	TxRX(DPLL)	DPLL Cycle Time Min	50		50		31		[7,8]
17	TcRTXX	Crystal Osc. Period	125	1000	100	1000	61	1000	[3]
18	TwTRXh	TRxC High Width	130		120		80		[6]
19	TwTRXl	TRxC Low Width	130		120		80		[6]
20	TcTRX	TRxC Cycle Time	472		400		244		[6,7]
21	TwEXT	DCD or CTS Pulse Width	200		120		70		
22	TwSY	SYNC Pulse Width	200		120		70		

Notes:

- [1] RxC is /RTxC or /TRxC, whichever is supplying the receive clock.
- [2] TxC is /TRxC or /RTxC, whichever is supplying the transmit clock.
- [3] Both /RTxC and /SYNC have 30 pF capacitors to ground connected to them.
- [4] Synchronization of RxC to PCLK is eliminated in divide by four operation.
- [5] Parameter applies only to FM encoding/decoding.
- [6] Parameter applies only for transmitter and receiver; DPLL and baud rate generator timing requirements are identical to case PCLK requirements.
- [7] The maximum receive or transmit data rate is 1/4 PCLK.
- [8] Applies to DPLL clock source only. Maximum data rate of 1/4 PCLK still applies. DPLL clock should have a 50% duty cycle.

AC CHARACTERISTICS
Z85230 System Timing Diagram

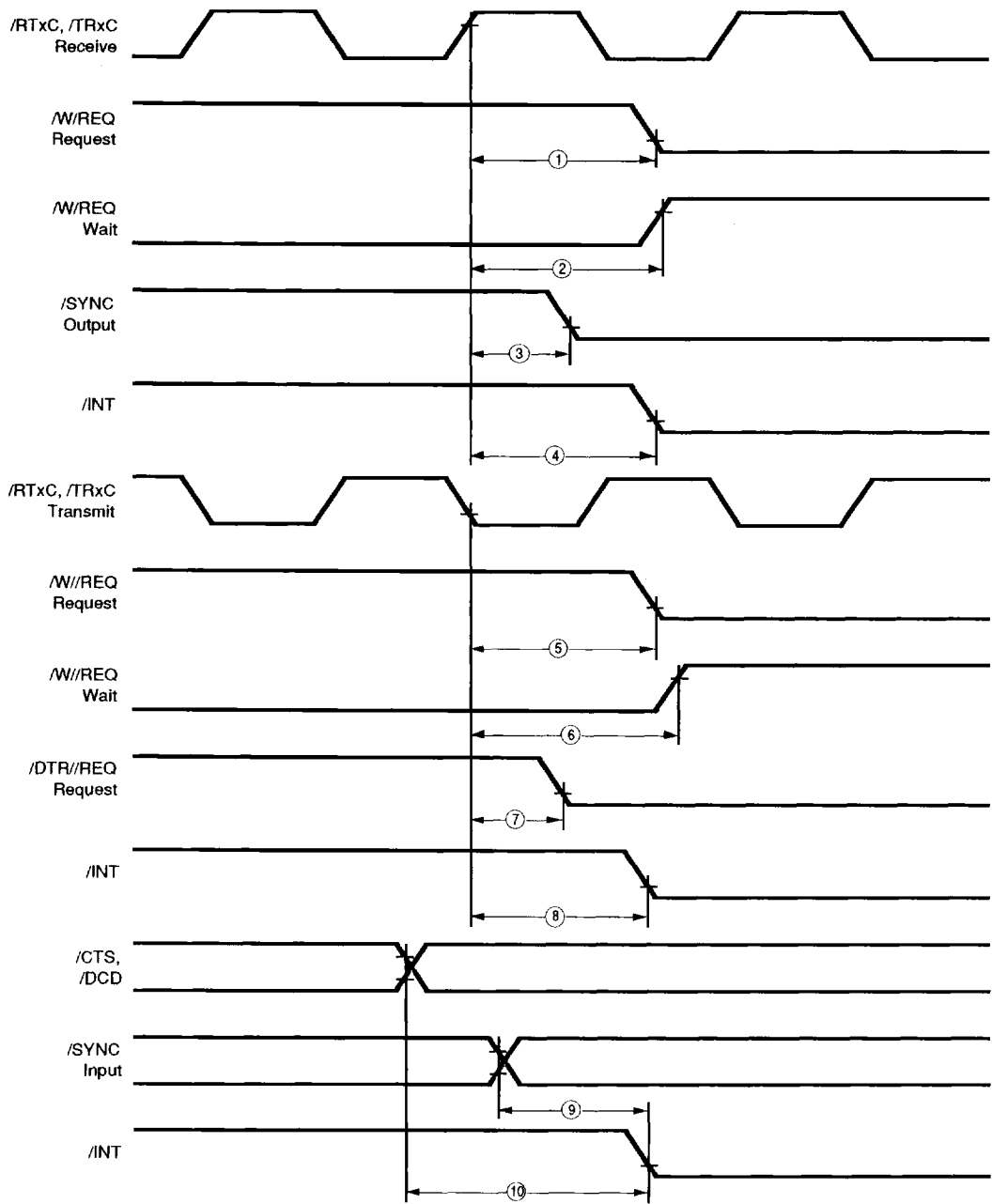

Figure 30. Z85230 System Timing

AC CHARACTERISTICS

Z85230 System Timing Table

No	Symbol	Parameter	8.5 MHz		10 MHz		16 MHz		Notes [4]
			Min	Max	Min	Max	Min	Max	
1	TdRXC(REQ)	/RXC to /W//REQ Valid	13	17	13	17	13	17	[2]
2	TdRXC(W)	/RxC to /Wait Inactive	13	17	13	17	13	17	[1,2]
3	TdRXC(SY)	/RxC to /SYNC Valid	9	12	9	12	9	12	[2]
4	TdRXC(INT)	/RxC to /INT Valid	15	21	15	21	15	21	[1,2]
5	TdTXC(REQ)	/TxC to /W//REQ Valid	8	11	8	11	8	11	[3]
6	TdTXC(W)	/TxC to /Wait Inactive	8	14	8	14	8	14	[1,3]
7	TdTXC(DRQ)	/TxC to /DTR//REQ Valid	7	10	7	10	7	10	[3]
8	TdTXC(INT)	/TxC to /INT Valid	9	13	9	13	9	13	[1,3]
9	TdSY(INT)	/SYNC to /INT Valid	2	6	2	6	2	6	[1]
10	TdEXT(INT)	/DCD or /CTS to /INT Valid	3	8	3	8	3	8	[1]

Notes:

- [1] Open drain-output, measured with open-drain test load.
- [2] /RxC is /RTxC or /TRxC, whichever is supplying the receive clock.
- [3] /TxC is /TRxC or /RTxC, whichever is supplying the transmit clock.
- [4] Units equal to TcPc.

MIL-STD-883 MILITARY PROCESSED PRODUCT

- MIL-STD-883 establishes uniform methods and procedures for testing microelectronic devices to insure the electrical, mechanical, and environmental integrity and reliability that is required for military applications.
- MIL-STD-883 Class B is the industry standard product assurance level for military ground and aircraft application.
- Compliant to 883 Class B, Revision C process requirements.
- The total reliability of a system depends upon test that are designed to stress specific quality and reliability concerns that affect microelectronic products.
- The following tables detail the 100% screening and electrical tests, sample electrical tests, and Qualification/Quality Conformance testing required.

Zilog Military Product Flow

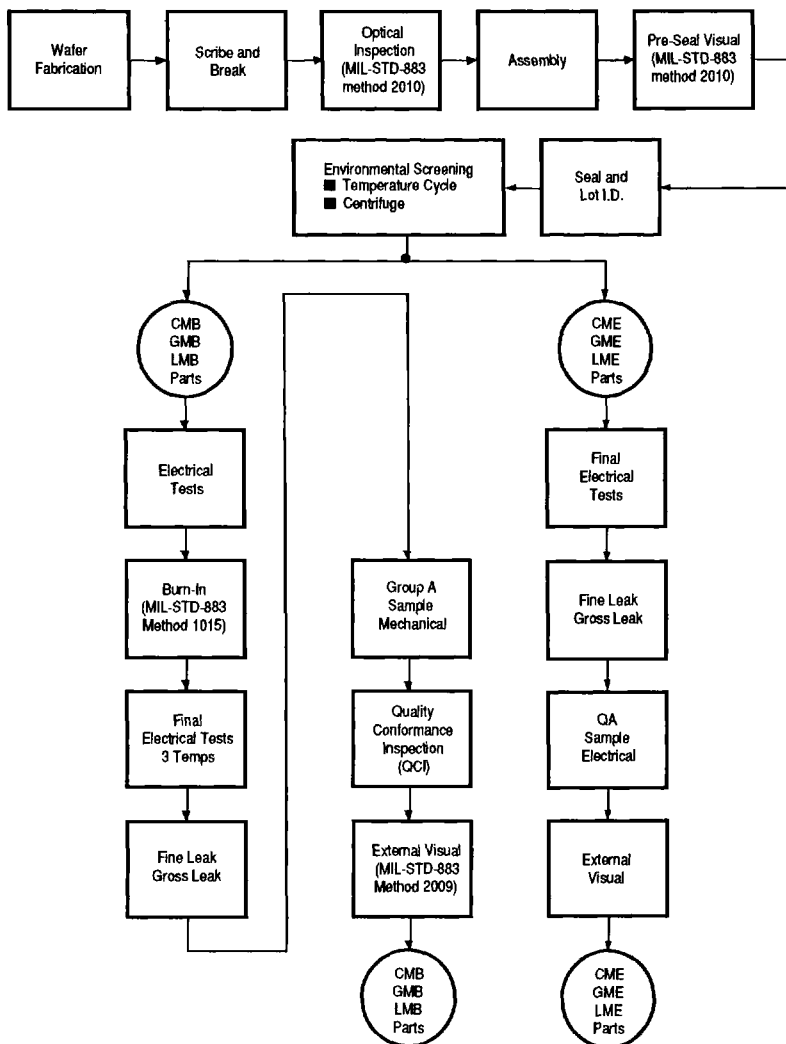

Table 1
MIL-STD-883 Class B Screening Requirements
Method 5004

Test	MIL-STD-883 Method	Test Condition	Requirement	
Internal Visual	2010	Condition B	100%	
Thermal Shock	1011	Condition B	100%	
Constant Acceleration (Centrifuge)	2001	Condition E or D ^(Note 1) , Y ₁ Axis Only	100%	
Initial Electrical Tests		Zilog Military Electrical Specification Static/DC T _c = +25°C	100%	
Burn-In	1015	Condition D ^(Note 2) , 160 hours, T _A = +125°C	100%	
Interim Electrical Tests		Zilog Military Electrical Specification Static/DC T _c = +25°C	100%	
PDA Calculation		PDA = 5%	100%	
Final Electrical Tests		Zilog Military Electrical Specification Static/DC T _c = +125°C, -55°C Functional, Switching/AC T _c = +25°C	100%	
Fine Leak	1014	Condition B	100%	
Gross Leak	1014	Condition C ₁	100%	
Quality Conformance Inspection (QCI)				
Group A	Each Inspection Lot	5005	(See Table II)	Sample
Group B	Every Week	5005	(See Table III)	Sample
Group C	Periodically ^(Note 3)	5005	(See Table IV)	Sample
Group D	Periodically ^(Note 3)	5005	(See Table V)	Sample
External Visual	2009			100%
QA-Ship				100%

Notes:

1. Applies to large packages which have an inner seal or cavity perimeter of two inches or more in total length or have a package mass of ≥ 5 grams.
2. In process of fully implementing of Condition D Burn-In Circuits. Contact factory for copy of specific burn-in circuit available.
3. Performed periodically as required by MIL-STD-883, paragraph 1.2.1 b (17).
4. Processing fully compliant to MIL-STD-883 Revision C requirements.

**Table II Group A
Sample Electrical Tests
MIL-STD-883 Method 5005**

Subgroup	Tests	Temperature (T _c)	SET Sample 116/0
Subgroup 1	Static/DC	+25°C	100%
Subgroup 2	Static/DC	+125°C	116/0
Subgroup 3	Static/DC	-55°C	116/0
Subgroup 7	Functional	+25°C	100%
Subgroup 8	Functional	-55°C and +125°C	116/0
Subgroup 9	Switching/AC	+25°C	100%
Subgroup 10	Switching/AC	+125°C	116/0
Subgroup 11	Switching/AC	-55°C	116/0

Notes:

1. The specific parameters to be included for tests in each subgroup shall be as specified in the applicable detail electrical specification. Where no parameters have been identified in a particular subgroup or test within a subgroup, no Group A testing is required for that subgroup or test.
2. Group A testing by subgroup or within subgroups may be performed in any sequence unless otherwise specified.
3. If any failure occurs during sample testing of any subgroup, then the lot is 100% tested at the failed subgroup only.

Table III Group B
Sample Test Performed Every Week to
Test Construction and Insure Integrity of Assembly Process
MIL-STD-883 Method 5005

Subgroup	MIL-STD-883 Method	Test Condition	Quantity or LTPD/Max Accept
Subgroup 2 Resistance to Solvents	2015		4/0
Subgroup 3 Solderability	2003	Solder Temperature +245°C ± 5°C	15 (Note 1)
Subgroup 5 Bond Strength	2011	C	15 (Note 2)

Notes:

1. Number of leads inspected selected from a minimum of three devices.
2. Number of bond pulls selected from a minimum of four devices.

Table IV Group C
Sample Test Performed Periodically to Verify Integrity of the Die
MIL-STD-883 Method 5005

Subgroup	MIL-STD-883 Method	Test Condition	Quantity or LTPD/Max Accept
Subgroup 1			
Steady State Operating Life	1005	Condition D ^(Note 1) , 100 hours at +125°C	5
End Point Electrical Tests		Zilog Military Electrical Specification T _c = +25°C, +125°C, -55°C	

Note:

1. In process of fully implementing Condition D Burn-In Circuits.
Contact factory for copy of specific burn-in circuit available.

Table V Group D
Sample Test Performed Periodically to Insure Integrity of the Package
MIL-STD-883 Method 5005

Subgroup	MIL-STD-883 Method	Test Condition	Quantity or LTPD/Max Accept
Subgroup 1 Physical Dimensions	2016		15
Subgroup 2	2028 (for PGA) or 2004	Condition B ₂ or D ^(Note 1)	5
Subgroup 3 Thermal Shock	1011	Condition B minimum, 15 cycles minimum	15
Temperature Cycling	1010	Condition C, 100 cycles minimum	
Moisture Resistance	1004	Condition B minimum	
Seal	1014		
3a) Fine Leak		3a) Condition B	
3b) Gross Leak		3b) Condition C	
Visual Examination	1004 or 1010		
End Point Electrical Tests		Zilog Military Electrical Specification T _c = +25°C, +125°C, -55°C	
Subgroup 4 Mechanical Shock	2002	Condition B minimum	15
Vibration Variable Frequency	2007	Condition A minimum	
Constant Acceleration (Centrifuge)	2001	Condition E or D ^(Note 2) , Y ₁ Axis Only	
Seal			
4a) Fine Leak		4a) Condition B	
4b) Gross Leak		4b) Condition C	
Visual Examination	1010 or 1011		
End Point Electrical Tests		Zilog Military Electrical Specification T _c = +25°C, +125°C, -55°C	
Subgroup 5 Salt Atmosphere	1009	Condition A minimum	15
Seal	1014		
5a) Fine Leak		5a) Condition B	
5b) Gross Leak		5b) Condition C	
Visual Examination	1009		
Subgroup 6 Internal Water Vapor Content	1018	5,000 ppm. maximum water content at +100°C	3/0 or 5/1
Subgroup 7 ^(Note 3) Adhesion of Lead Finish	2025		15 (Note 4)
Subgroup 8 ^(Note 5) Lid Torque	2024		5/0

Notes:

- | | |
|---|--|
| 1. Lead Integrity Condition D for leadless chip carriers. | 3. Not applicable to leadless chip carriers. |
| 2. Applies to larger packages which have an inner seal or cavity perimeter of two inches or more in total length or have a package mass of ≥ 5 grams. | 4. LTPD based on number of leads. |
| | 5. Not applicable for solder seal packages. |

PACKAGE INFORMATION

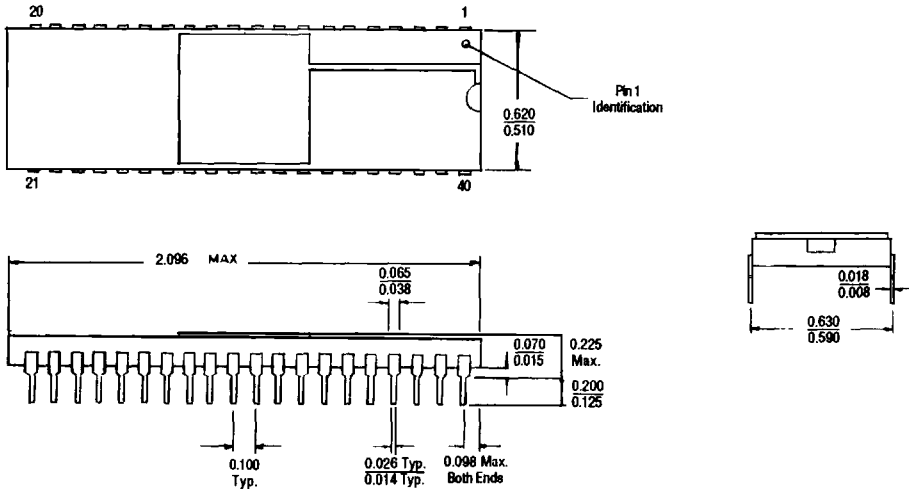

40-Pin Ceramic DIP Package Diagram

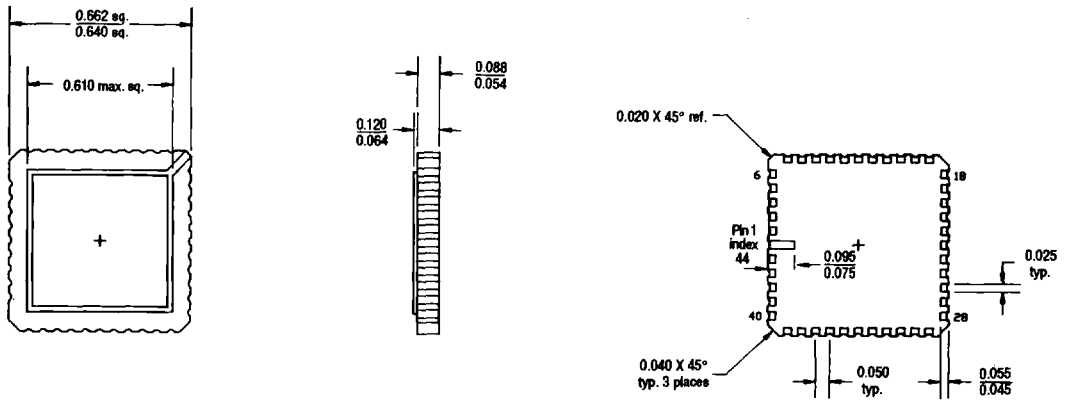

44-Pin Ceramic LCC Package Diagram

ORDERING INFORMATION

Z85230

8 MHz	10 MHz	16 MHz
Z8523008CMB	Z8523010CMB	Z8523016CMB
Z8523008LMB	Z8523010LMB	Z8523016LMB
Z8523008CME	Z8523010CME	Z8523016CME
Z8523008LME	Z8523010LME	Z8523016LME

Package

C = Ceramic
L = Ceramic LCC

Temperature

M = -55°C to +125°C

Speeds

8 = 8.0 MHz
10 = 10.0 MHz
16 = 16.384 MHz

Environmental

E = Hermetic Standard
B = 883 Class B Military

Example:

Z 85230 10 C M B is a Z85230, 10 MHz, DIP, Ceramic, Mil Temp, 883B Rev. C

