

Connectors

SSMA for Semi-Rigid Cable .085 Direct Solder Attachment

Straight Male Cable Plug

Cable Type (RG/U)	Model Number	Fig.
405 (.085 Dia.)	SSM-0085-92-000-00	I
405 (.085 Dia.)	SSM-0085-79-000-00	II

Fig I = uses center conductor of cable

Fig II = uses solder type center contact

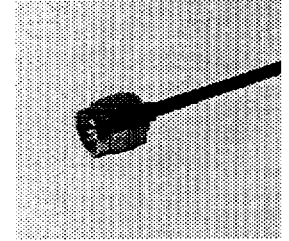
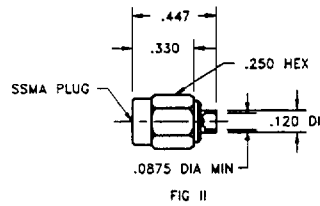
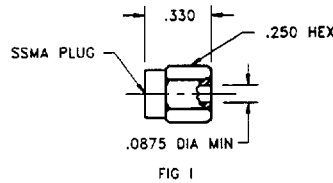

Note: Standard finish is gold plating for direct solder to cable, for passivated coupling nut change -00 suffix to -02.

Straight Bulkhead Feedthru Female Cable Jack

Cable Type (RG/U)	Model Number
405 (.085 Dia.)	SSM-0085-83-000-00

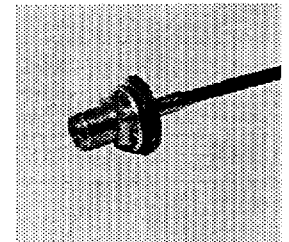
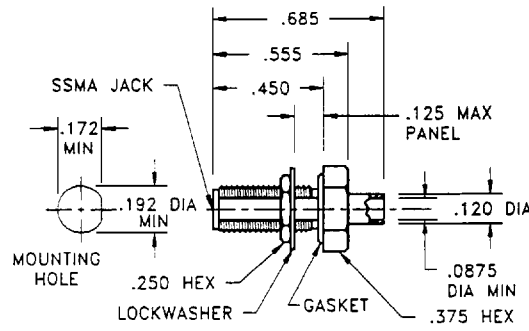

Note: Standard finish is gold plating for direct soldering to cable.

Straight Panel Mount Female Cable Jack - 4 Hole

Cable Type (RG/U)	Model Number
405 (.085 Dia.)	SSM-0085-84-000-00

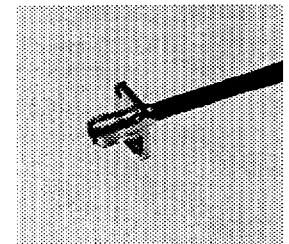
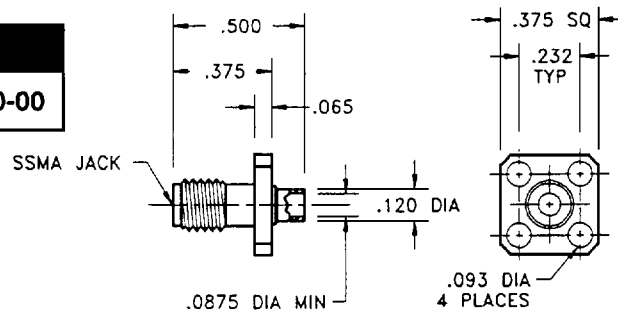

Note: Standard finish is gold plating for direct soldering to semi-rigid cable.

Right Angle Male Cable Plug

Cable Type	Model Number
405 (.085 Dia.)	SSM-0085-80-000-02

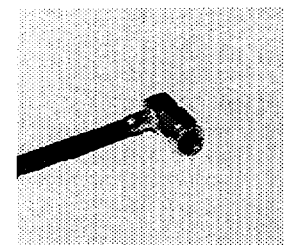
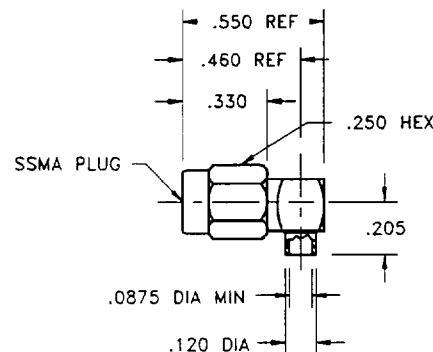

Note: Standard finish is gold plating for direct solder to semi-rigid cable, for passivated coupling nut change -00 suffix to -02.
Detail interface dimensions and RG/U cable information can be found in the appendix.