

ADSL-Transformer WSL-A31.300

Specifications



Application

CPE, ALCATEL DynaMiTe MTK-20140 Chipset

Safety Agency

IEC 950

Features

Optimized magnetic shielding for low interference
High performance, high quality design
SMT and THT package available

Packaging

100 pcs./tray
7 trays/carton

Solderability

270 - 300°C

Isolation voltage

1500 VAC

Operation Temperature Range

-40°C to +85°C

Marking

 article-no.

Unit Weight

6g

Schematics & Mechanicals (mm)

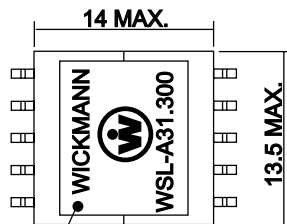
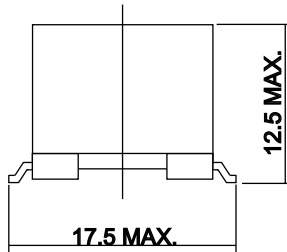

BLACK DOT IS PIN NO.1

WebLinks

Data Sheet

www.wickmann.com/products/WSL_A31300.pdf

Packaging

www.wickmann.com/pack

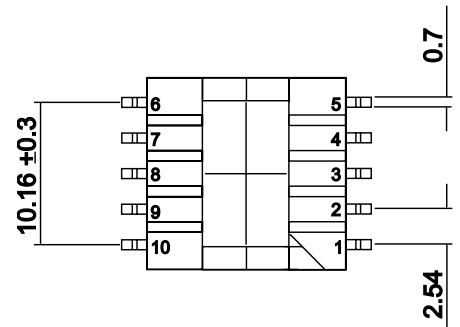
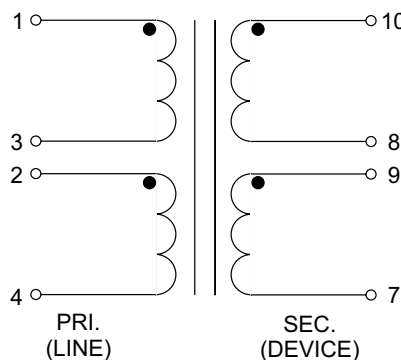

DC Resistance:	1,0 Ω (1-4) max. ±10% 1,0 Ω (7-10) max. ±10%
Open Circuit Inductance:	480μH ±10% @ 10kHz, 100mVAC on series, (7-10), short (8+9)
Turns Ratio:	1:1 ±2% (1-4):(10-7)
Leakage Inductance:	10,0μH max. 300kHz, 100mVAC (1-4), short (2+3, 7+10, 8+9)
Longitudinal Balance:	-
Interwinding Capacity:	-
Reflects 100Ω @ R _L =	-
Insertion Loss:	1,0dB max. @ 100kHz, 1MHz
Total Harmonic Distortion (THD):	-72dB min. @ 20kHz

Order Information

Qty.	Order Number
	960 4 631300 9