

OKI electronic components

KGF1265

Medium-Power Amplifier

GENERAL DESCRIPTION

The KGF1265 is a medium-power amplifier, with frequencies ranging from the UHF-band, that features high output power, low distortion, and low current operation. The KGF1265 specifications are guaranteed to a fixed matching circuit for 3 V and 900 MHz band; external impedance-matching circuits are also required. Because of the high output power and low distortion at the low operating current, the KGF1265 is ideal as a transmitter-driver amplifier for portable phones such as PDC and CDMA.

FEATURES

- High output power: 11 dBm (min.)
- Low voltage and low current operation: 3 V, 18 mA (max.)
- Low distortion (ACP): -55 dBc (max) @ $P_O = 8$ dBm, $\pi/4$ DQPSK, ± 50 kHz
- Self-bias circuit configuration with built-in source capacitor
- package: 4PSOP

PACKAGE DIMENSIONS

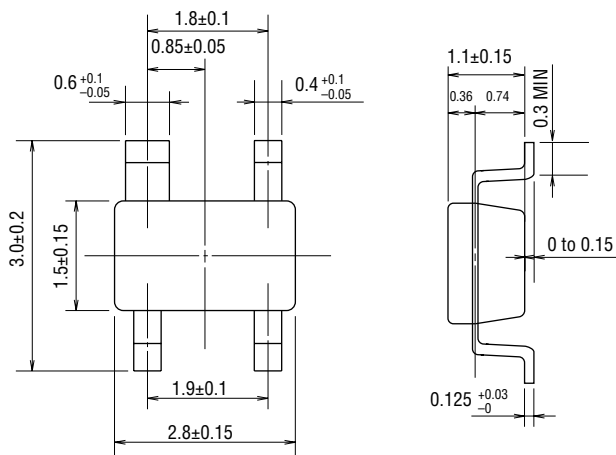

(Unit: mm)

Package material	Epoxy resin
Lead frame material	42 alloy
Pin treatment	Solder plating
Solder plate thickness	5 μ m or more

MARKING

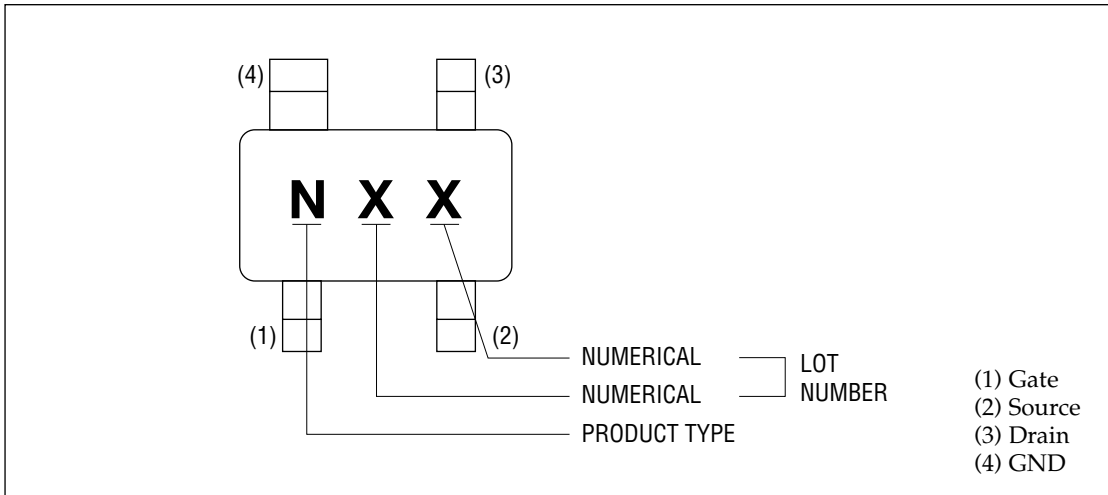

CIRCUIT

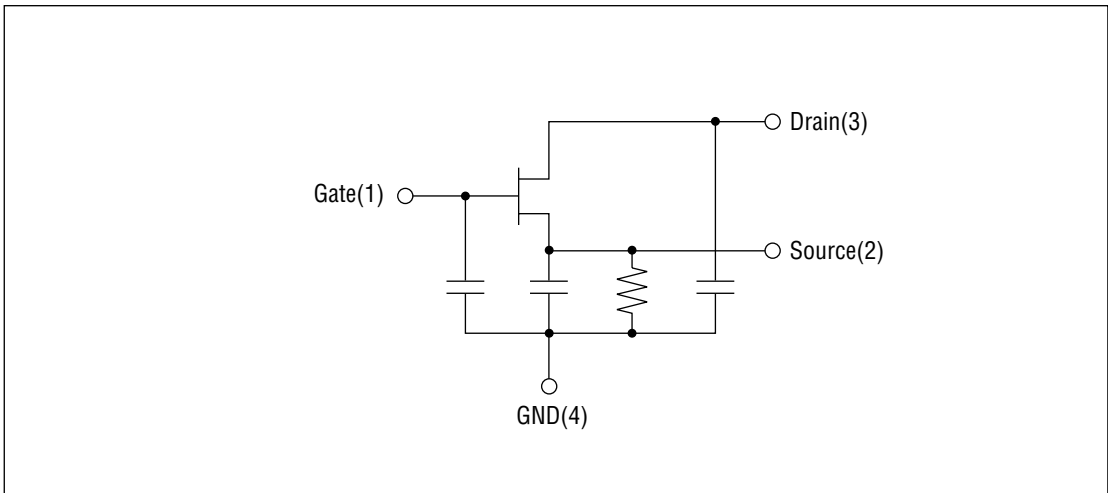

ABSOLUTE MAXIMUM RATINGS

Item	Symbol	Condition	Unit	Min.	Max.
Drain-source voltage	V_{DS}	$T_a = 25^\circ\text{C}$	V	—	8
Gate-source voltage	V_{GS}	$T_a = 25^\circ\text{C}$	V	-3.0	0.4
Drain current	I_{DS}	$T_a = 25^\circ\text{C}$	mA	—	28
Total power dissipation	P_{tot}	$T_a = 25^\circ\text{C}$	mW	—	200
Channel temperature	T_{ch}	—	$^\circ\text{C}$	—	150
Operating temperature	T_{ope}	—	$^\circ\text{C}$	-35	85
Storage temperature	T_{stg}	—	$^\circ\text{C}$	-45	125

ELECTRICAL CHARACTERISTICS

(Ta = 25°C)

Item	Symbol	Condition	Unit	Min.	Typ.	Max.
Frequency	f		MHz	889	—	960
Operating current	I_D	(*1), $P_{IN} = 0 \text{ dBm}$	mA	—	—	18.0
Linear gain	G_{LIN}	(*1), $P_{IN} = -20 \text{ dBm}$	dB	13.0	15.0	—
Output power	P_O	(*1), $P_{IN} = 0 \text{ dBm}$	dBm	11.0	12.5	—
Adjacent Channel Power 1	ACP1	(*1), $P_O = 8 \text{ dBm}$, $\pm 50 \text{ kHz offset}$	dBc	—	-60	-55
Adjacent Channel Power 2	ACP2	(*1), $P_O = 8 \text{ dBm}$, $\pm 100 \text{ kHz offset}$	dBc	—	-70	-65
Noise figure	F	(*1)	dB	—	—	3.0

*1 Self-bias condition: $V_{DD} = 3 \text{ V}$, $V_G = 0 \text{ V}$

RF CHARACTERISTICS

KGF1265
 P_o , IM_3 and I_D vs. P_{IN}

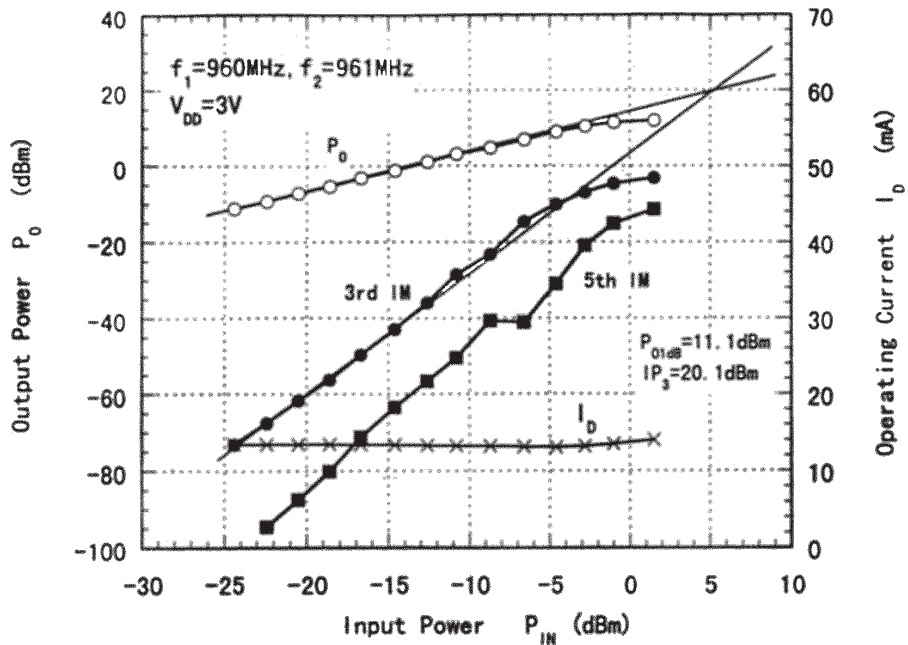

KGF1265
 P_o , ACP1 and ACP2 vs. P_{IN}

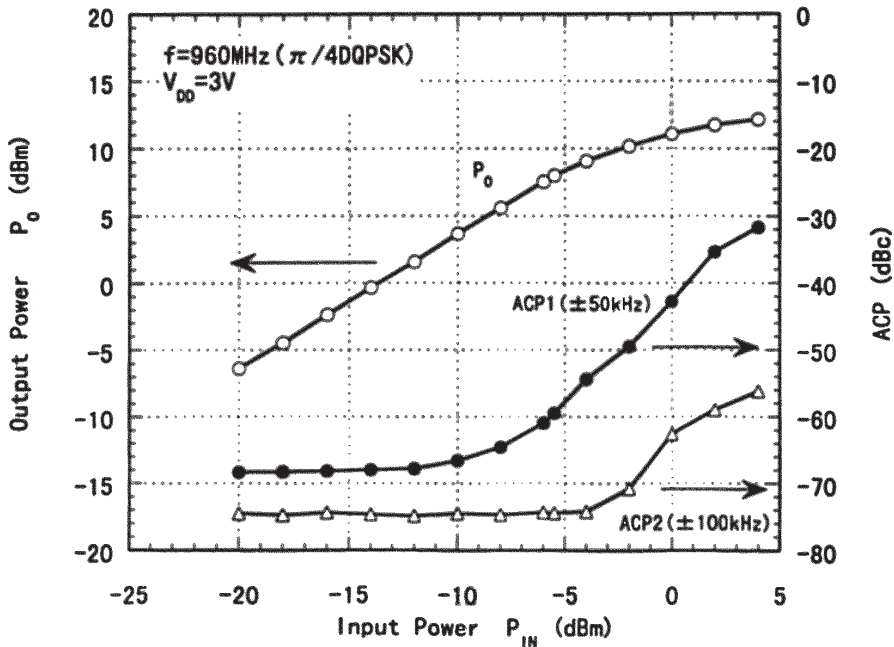

KGF1265 Thermal Stability
 P_o, I_D vs. P_{IN}

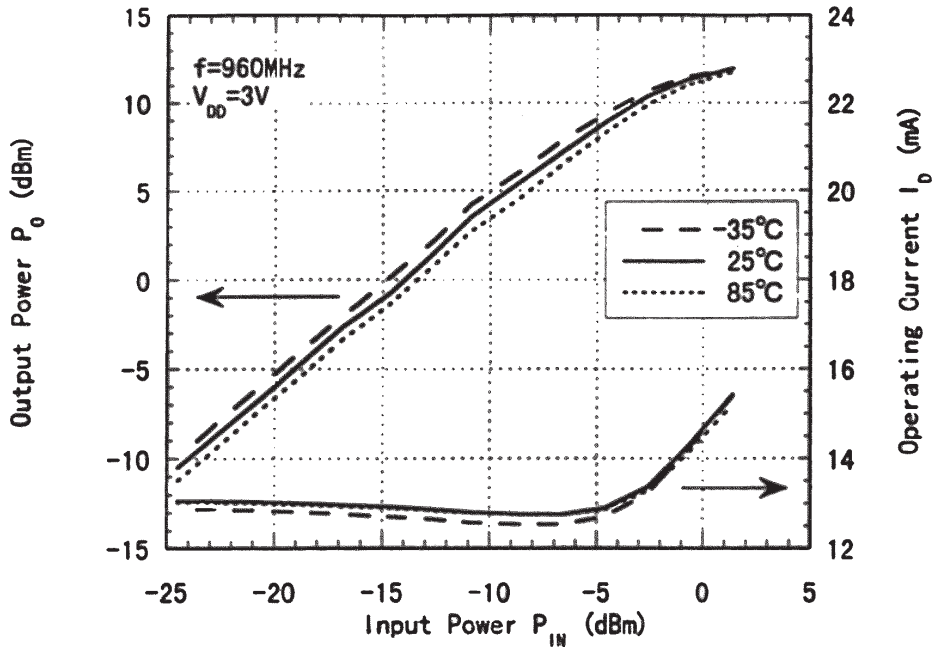

KGF1265 Thermal Stability
 $P_o, \text{ACP1}$ vs. P_{IN}

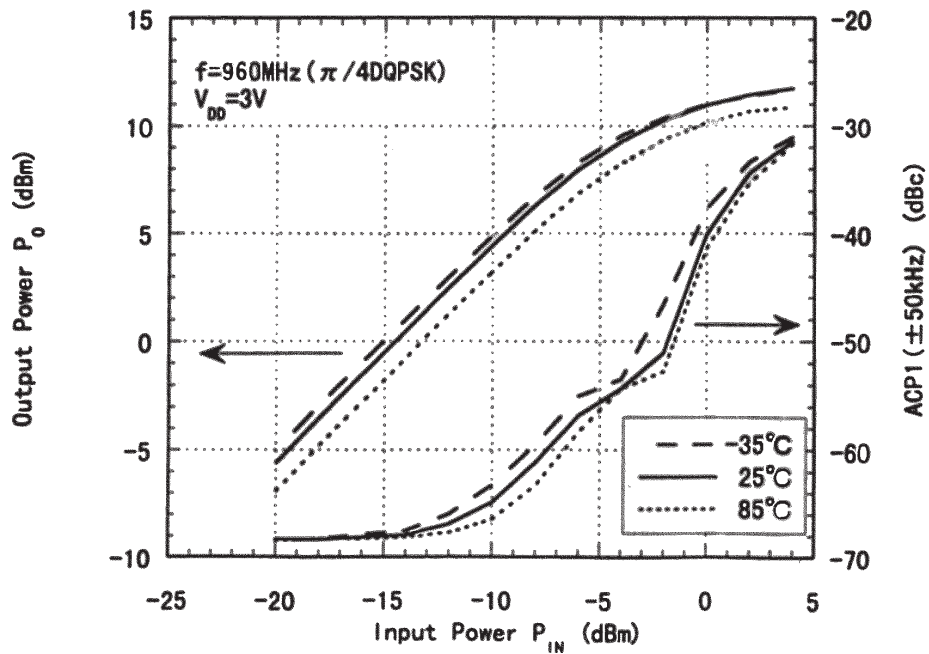

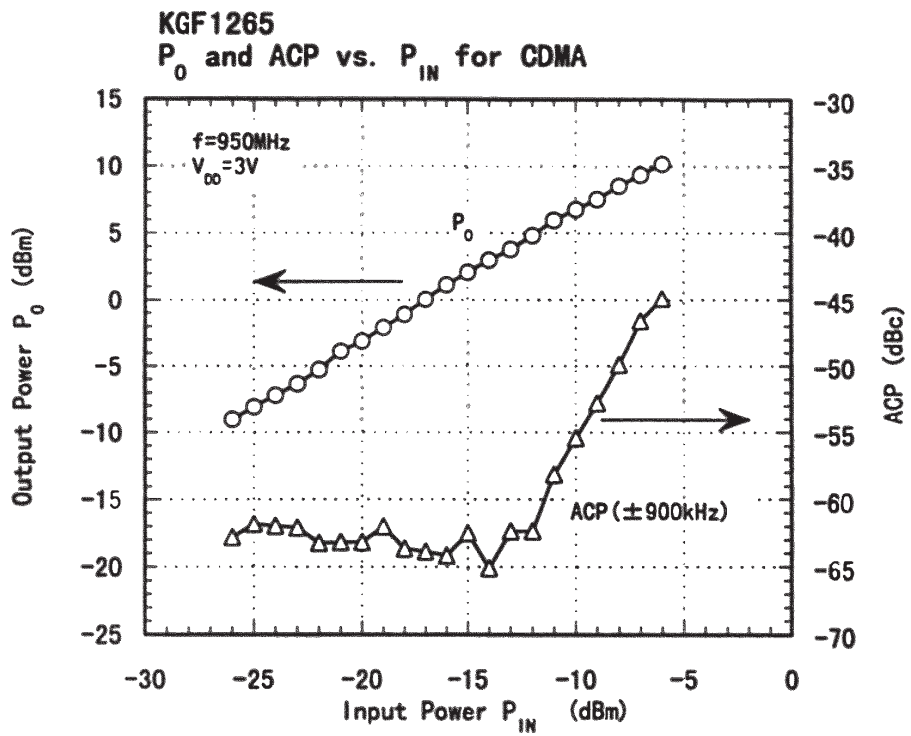

Typical S Parameters

 $V_{DD} = 3\text{ V}$

Freq(MHz)	MAG(S ₁₁)	ANG(S ₁₁)	MAG(S ₂₁)	ANG(S ₂₁)	MAG(S ₁₂)	ANG(S ₁₂)	MAG(S ₂₂)	ANG(S ₂₂)
500.0	0.915	-54.66	4.476	128.63	0.062	33.24	0.598	-76.25
600.0	0.862	-65.63	4.351	117.04	0.059	30.50	0.531	-85.34
700.0	0.813	-75.40	4.134	107.13	0.057	29.69	0.492	-92.80
800.0	0.770	-85.38	3.986	97.98	0.056	30.85	0.469	-99.26
900.0	0.735	-93.08	3.699	89.86	0.054	33.11	0.455	-106.30
1000.0	0.708	-102.19	3.565	82.40	0.054	36.50	0.453	-111.84
1100.0	0.686	-110.12	3.386	74.99	0.053	42.10	0.451	-117.81
1200.0	0.668	-117.86	3.244	68.15	0.055	47.65	0.459	-123.09
1300.0	0.662	-123.89	3.032	62.32	0.058	54.31	0.466	-128.56
1400.0	0.655	-130.53	2.870	55.64	0.063	59.01	0.479	-133.39
1500.0	0.654	-136.56	2.732	49.96	0.070	63.77	0.492	-138.40
1600.0	0.655	-141.96	2.563	44.30	0.079	66.59	0.509	-142.96
1700.0	0.657	-147.69	2.454	38.52	0.089	68.50	0.525	-147.66
1800.0	0.665	-152.50	2.297	33.19	0.099	69.01	0.545	-152.30
1900.0	0.673	-157.31	2.157	28.11	0.112	68.50	0.563	-156.46
2000.0	0.679	-162.17	2.062	22.74	0.125	67.98	0.582	-161.01
2100.0	0.686	-166.90	1.939	17.68	0.139	66.28	0.599	-165.29
2200.0	0.691	-171.49	1.831	12.95	0.151	64.42	0.617	-169.54
2300.0	0.698	-175.91	1.728	8.07	0.166	61.90	0.634	-173.69
2400.0	0.703	-179.67	1.644	3.82	0.177	59.48	0.649	-178.01
2500.0	0.706	-175.24	1.528	-1.22	0.195	56.31	0.661	-177.84
2600.0	0.706	-170.85	1.466	-5.08	0.204	53.81	0.675	-173.58
2700.0	0.710	-166.54	1.354	-8.96	0.219	50.11	0.683	-169.29
2800.0	0.711	-162.28	1.297	-13.82	0.229	47.47	0.694	-164.93
2900.0	0.711	-158.25	1.192	-16.22	0.242	43.57	0.700	-160.94
3000.0	0.710	-153.79	1.145	-20.50	0.254	41.41	0.707	-156.55

Typical S Parameters

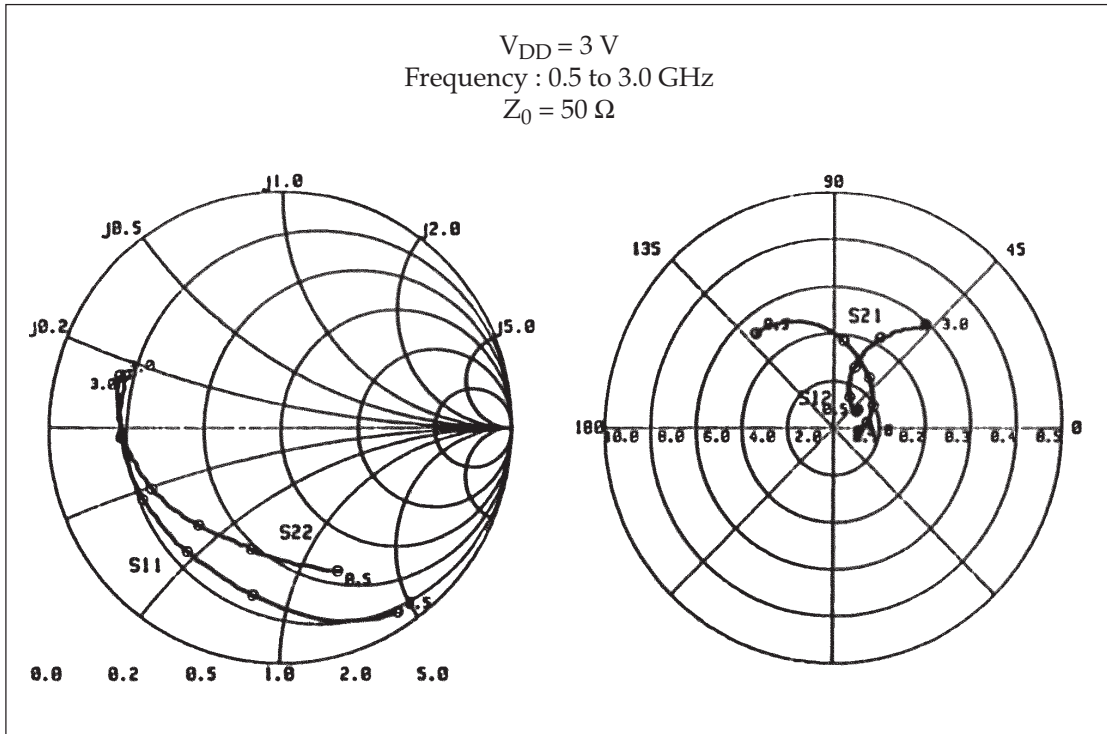

Test Circuit ($V_{DD} = 3\text{ V}$, $f = 889\text{ MHz to }960\text{ MHz}$)

