

RevNo	Revision note	Date	Signature	Checked
A	ORIGINAL	03-08-10		

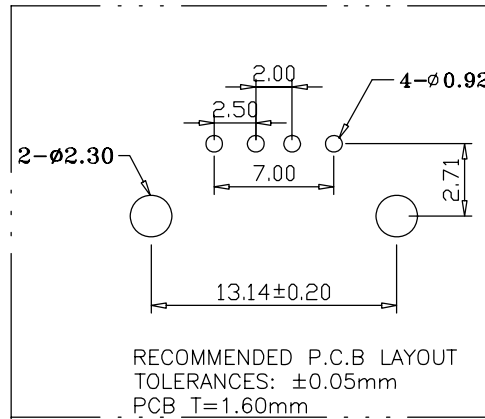
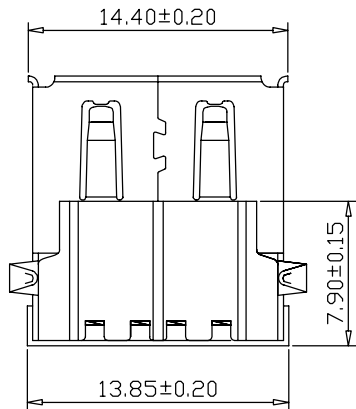
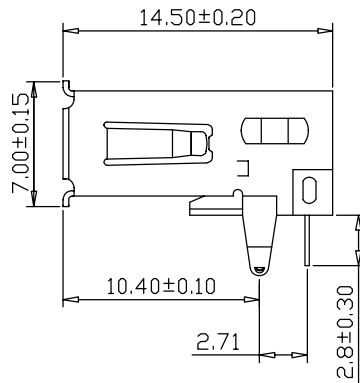
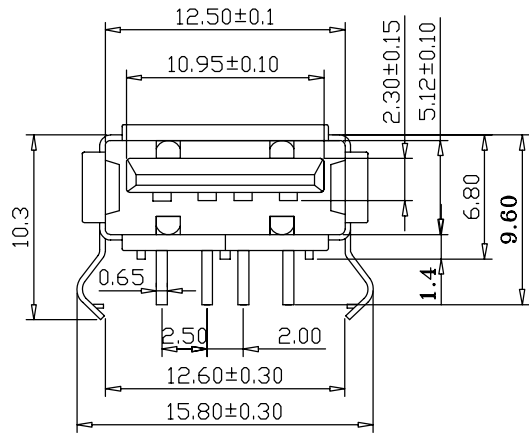

Note:

1.Material:

- 1.1 Insulator: P.B.T G.F UL 94-V0 rated.
- 1.2 Contact: Brass,t=0.25mm.
- 1.3 Shell: Brass,t=0.30mm.

2.Specification:

- 2.1 Rated voltage and current: 1.5A at 250V AC minimum.
- 2.2 Dielectric withstanding voltage: 500V AC/1 minute without breakdown.
- 2.3 Contact resistance: Before life test 30m ohm max, After life test 50m ohm max.
- 2.4 Insulation resistance: 1000M ohm min.
- 2.5 Insertion force: 35 Newtons maximum.
- 2.6 Extraction force: 10 Newtons minimum.
- 2.7 Solderability: Terminal shall be immersed in flux before test Then dip in molten solder for 5±0.5 sec. At 245±5°C.

3.Finishes:

- 3.1 Contacts: Gold flashed 1u"~30u". Solder area: 40u"nickel over 60~100u" tin.
- 3.2 Shell: 0.8~1.2u" Gold plated.

PART NO.

USB-317 A X 04 X X A 1 0 0 X  
1 2 3 4 5 6 7 8 9 10 11

- 1.SERIES NO.
- 2.TYPE  
A=Standard
- 3.ENVIRONMENT PROTECTION  
MATERIAL:  
E=RoHS  
G=RoHS(Halogen Free)
- 4.CONTACT NUMBER  
04
- 5.CONTACT TYPE  
P=Female(Shell Nickel)  
J=Female(Shell Gold Flash)
- 6.CONTACT PLATING  
G=Gold Flash  
S=Gold Flash (Selective)  
A=5u" Gold (Selective)  
B=5u" Gold (Selective)  
C=15u" Gold (Selective)  
D=30u" Gold (Selective)
- 7.FUNCTION  
A=A Type
- 8.SHELL  
1=Rear Cover
- 9.ANGLE  
0=Right Angle
- 10.FILL IT WITH"0"
- 11.INSULATOR COLOR  
1=White  
3=Black

NO.	Name	Q'TY	Material	Remarks & Thickness	Finish
3	Shell	1	Copper alloy	T=0.30mm	Nickel/Gold Flash
2	Contact	4	Copper alloy	T=0.25mm	1u'~ 30u" Selective Gold
1	Housing	1	P.B.I	UL 94-V0	Black/Ivory

GENERAL TOLERANCES ( UNLESS SPECIFIED ) DIMENSION STYLE : MM ( INCH )		FINISH		TITLE	
MM	INCH	SEE NOTES		USB TYPE A, RECPT, R/A, 4P, TH	
4 PLACES	± .---	DRAWN BY		DATE	
3 PLACES	± 0.10	REMY		03-08-10	
2 PLACES	± 0.20	CHECKED BY		DATE	
1 PLACES	± 0.30	CARDL		03-08-10	
0 PLACES	± ---	APPROVED BY		DATE	
ANGULAR ± 1		---		SCALE	SHEET
THIRD ANGLE PROJECTION		---		NONE	1 OF 2



USB TYPE A, RECPT, R/A, 4P, TH

DRAWING NO. USB-317AX04XXA100X

SHEET 1 OF 2 REV. A

RevNo	Revision note	Date	Signature	Checked
A	ORIGINAL	03-08-10		

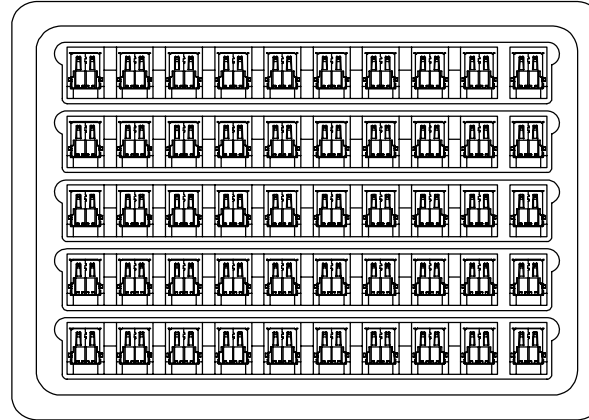
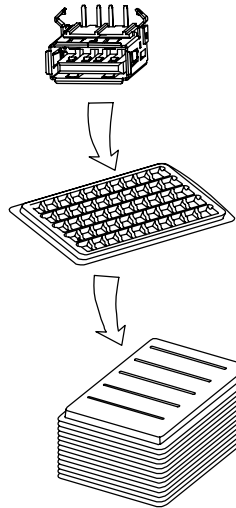
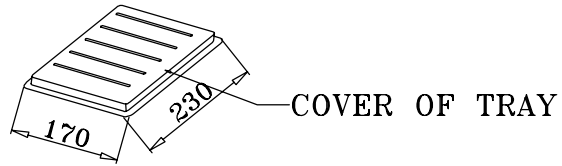

TPRA LAYOUT

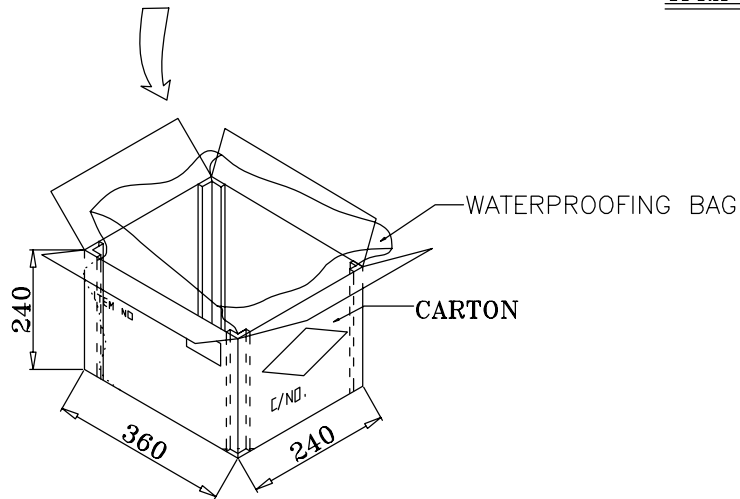

- NOTES:
1. Material:
    - 1.1 Tray: APET
    - 1.2 Shipping carton: corrugated fiberboard 0.68"
    - 1.3 Waterproofing bag: PE
  2. Dimension:
    - 2.1 Tray: H=10
  3. Quantity:
    - 3.1 Primary packing: 50 PCS/Tray
    - 3.2 Secondary packing: 40 Trays (2000PCS)
  4. Weight:
    - 4.1 Net weight: 5.4Kg
    - 4.2 Gross weight: 6.7Kg

GENERAL TOLERANCES ( UNLESS SPECIFIED ) DIMENSION STYLE : MM ( INCH )		FINISH SEE NOTES		MATERIAL SEE NOTES		TITLE	
4 PLACES	± --- ± ---	DRAWN BY	DATE	Remy		USB TYPE A, RECPT, R/A, 4P, TH	
3 PLACES	± 0.10 ± ---	CHECKED BY	DATE	CARDL		SIZE	DRAWING NO.
2 PLACES	± 0.20 ± ---	APPROVED BY	DATE	---		A4	USB-317AX04XXA100X
1 PLACES	± 0.30 ± ---			SCALE	SHEET		REV.
0 PLACES	± --- ± ---			NONE	2	OF 2	A
ANGULAR ± 1°							
THIRD ANGLE PROJECTION							

