

**MR16R0824(6/8/C/G)AN1**  
**MR18R0824(6/8/C/G)AN1**

**Change History**

<b>Version 1.0 (August 1999) - Preliminary</b>	
* First copy.	
* Based on the Rambus RIMM Datasheet Rev.1.0.	

<b>Version 1.01 (October 1999)</b>	
<b>Page No.</b>	<b>Change Description</b>
<b>1</b>	- Delete the part numbers of low power.
<b>6</b>	- Add the plate temperature value, T <sub>PLATE</sub> to 92°C.
<b>10</b>	- Correct the Component height. - Correct the tolerance from ±0.13mm to ±0.127mm.
<b>11</b>	- Correct the heat spreader thickness on double sided modules to 7.07±0.30mm.
<b>12</b>	- Change the marked text of Standard RIMM Module Marking Information as follows * from "16d,12d,8d,6d,4d" to "/16,/12,/8,/6,/4" @ Number of RDRAMs * to "Gerber : 10 = 1.0ver / SPD : 0 = 1.0ver" @ Gerber & SPD version Field. * from 53.3 to 53 @ tRAC Field.

<b>Version 1.02 (January 2000)</b>	
<i>* Change the part number of RIMM Module based upon to New Code System since 00.Jan.1st</i>	
<b>Page No.</b>	<b>Change Description</b>
<b>8</b>	- Relax CMOS impedance for CMD,SCK from 28Ω±10% to 28Ω±15%.
<b>11</b>	- Change the heat spreader thickness including PCB to max. 7.80mm for double sided RIMM and max. 4.70mm for single sided RIMM.

<b>Version 1.1 (October 2000)</b>													
<i>* Update based on the latest Rambus RIMM Datasheet</i>													
<b>Page No.</b>	<b>Change Description</b>												
<b>6</b>	- Correct V <sub>CMOS</sub> to V <sub>DD</sub> & Add V <sub>SPD</sub> condition												
<b>8</b>	- Change the symbol of module impedance : From (Z) Module Impedance for RSL & CMOS To (Z <sub>L</sub> ) for RSL and (Z <sub>UL-CMOS</sub> ) for SCK, CMOS - Relax the RIMM CMOS delta tPD spec. from ±100ps to ±250ps - Add delta tPD spec for SCK-CMD of ±200ps												
<b>9</b>	- Relax tPD as follows												
	<table border="1"> <thead> <tr> <th></th> <th><b>16d</b></th> <th><b>8d</b></th> <th><b>4d</b></th> </tr> </thead> <tbody> <tr> <td><b>OLD</b> (-800 &amp; -711MHz/-600MHz)</td> <td>2.06 / 2.10ns</td> <td>1.50 / 1.60ns</td> <td>1.25ns</td> </tr> <tr> <td><b>NEW</b> (-800,-711&amp;-600MHz)</td> <td>2.11ns</td> <td>1.56ns</td> <td>1.28ns</td> </tr> </tbody> </table>		<b>16d</b>	<b>8d</b>	<b>4d</b>	<b>OLD</b> (-800 & -711MHz/-600MHz)	2.06 / 2.10ns	1.50 / 1.60ns	1.25ns	<b>NEW</b> (-800,-711&-600MHz)	2.11ns	1.56ns	1.28ns
	<b>16d</b>	<b>8d</b>	<b>4d</b>										
<b>OLD</b> (-800 & -711MHz/-600MHz)	2.06 / 2.10ns	1.50 / 1.60ns	1.25ns										
<b>NEW</b> (-800,-711&-600MHz)	2.11ns	1.56ns	1.28ns										

MR16R0824(6/8/C/G)AN1  
MR18R0824(6/8/C/G)AN1

---

Version 1.1 (October 2000)						
<b>9</b>	- Change attenuation limit at 600MHz					
		<b>16d</b>	<b>12d</b>	<b>8d</b>	<b>6d</b>	<b>4d</b>
	<b>OLD</b>	21%	18%	10%	9%	8%
	<b>NEW</b>	18.5%	15.5%	12.5%	11.5%	10.5%

# MR16R0824(6/8/C/G)AN1 MR18R0824(6/8/C/G)AN1

**(8Mx16)\*4(6/8/12/16)pcs RIMM™ Module based on 128Mb A-die, 32s banks,16K/32ms Ref, 2.5V**  
**(8Mx18)\*4(6/8/12/16)pcs RIMM™ Module based on 144Mb A-die, 32s banks,16K/32ms Ref, 2.5V**

## Overview

The Rambus® RIMM™ module is a general purpose high-performance memory module suitable for use in a broad range of applications including computer memory, personal computers, workstations, and other applications where high bandwidth and low latency are required.

The Rambus RIMM module consists of 128Mb/144Mb Direct Rambus DRAM devices. These are extremely high-speed CMOS DRAMs organized as 8M words by 16 or 18 bits. The use of Rambus Signaling Level (RSL) technology permits 600 MHz, 711 MHz or 800 MHz transfer rates while using conventional system and board design technologies. RDRAM devices are capable of sustained data transfers at 1.25 ns per two bytes (10ns per 16 bytes).

The RDRAM architecture enables the highest sustained bandwidth for multiple, simultaneous, randomly addressed, memory transactions. The separate control and data buses with independent row and column control yield over 95% bus efficiency. The RDRAM's 32-bank architecture supports up to four simultaneous transactions per device.

## Features

- ◆ High speed 800, 711 and 600MHz RDRAM storage
- ◆ 184 edge connector pads with 1mm pad spacing
- ◆ Module PCB size : 133.35mm x 31.75mm x1.27mm (5.25" x 1.25" x 0.05")
- ◆ Each RDRAM has 32 banks, for a total of 512, 384, 256, 192, or 128 banks on each 256/288MB, 192/216MB, 128/144MB, 96/108MB, or 64/72MB module respectively
- ◆ Gold plated edge connector pad contacts
- ◆ Serial Presence Detect (SPD) support
- ◆ Operates from a 2.5 volt supply (±5%)
- ◆ Powerdown self refresh modes
- ◆ Separate Row and Column buses for higher efficiency
- ◆ μ-BGA package (62 Balls)

## Key Timing Parameters/Part Numbers

The following table lists the frequency and latency bins available for RIMM modules.

**Table 1: Part Number by Freq. & Latency**

Organization	Speed			Part Number
	Bin	I/O Freq. (MHz)	t <sub>RAC</sub> (Row Access Time) ns	
32M x 16/18	-CK8	800	45	MR16/18R0824AN1-CK8
	-CK7	711	45	MR16/18R0824AN1-CK7
	-CG6	600	53.3	MR16/18R0824AN1-CG6
48M x 16/18	-CK8	800	45	MR16/18R0826AN1-CK8
	-CK7	711	45	MR16/18R0826AN1-CK7
	-CG6	600	53.3	MR16/18R0826AN1-CG6
64M x 16/18	-CK8	800	45	MR16/18R0828AN1-CK8
	-CK7	711	45	MR16/18R0828AN1-CK7
	-CG6	600	53.3	MR16/18R0828AN1-CG6
96M x 16/18	-CK8	800	45	MR16/18R082CAN1-CK8
	-CK7	711	45	MR16/18R082CAN1-CK7
	-CG6	600	53.3	MR16/18R082CAN1-CG6
128M x 16/18	-CK8	800	45	MR16/18R082GAN1-CK8
	-CK7	711	45	MR16/18R082GAN1-CK7
	-CG6	600	53.3	MR16/18R082GAN1-CG6

## Form Factor

The Rambus RIMM modules are offered in 184-pad 1mm edge connector pad pitch suitable for 184 contact RIMM connectors. Figure 1 below, shows a sixteen device Rambus RIMM module.

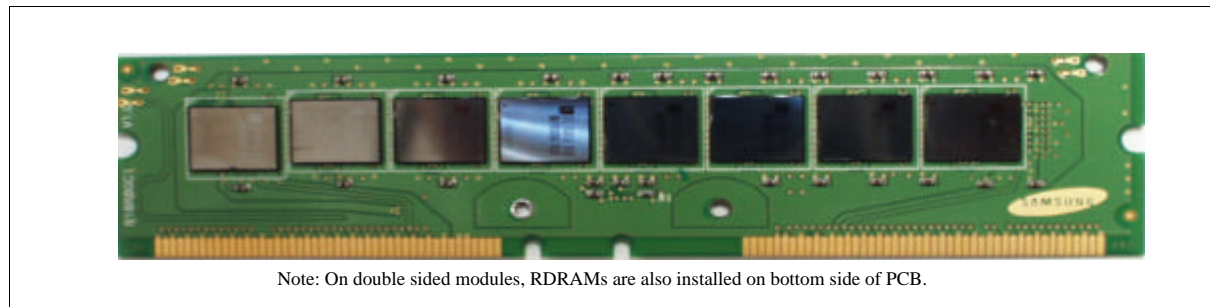

**Figure 1: Rambus RIMM Module shown with heat spreader removed**

**MR16R0824(6/8/C/G)AN1**  
**MR18R0824(6/8/C/G)AN1**

**Table 2: Module Pad Numbers and Signal Names**

Pin	Pin Name	Pin	Pin Name
A1	Gnd	B1	Gnd
A2	LDQA8	B2	LDQA7
A3	Gnd	B3	Gnd
A4	LDQA6	B4	LDQA5
A5	Gnd	B5	Gnd
A6	LDQA4	B6	LDQA3
A7	Gnd	B7	Gnd
A8	LDQA2	B8	LDQA1
A9	Gnd	B9	Gnd
A10	LDQA0	B10	LCFM
A11	Gnd	B11	Gnd
A12	LCTMN	B12	LCFMN
A13	Gnd	B13	Gnd
A14	LCTM	B14	NC
A15	Gnd	B15	Gnd
A16	NC	B16	LROW2
A17	Gnd	B17	Gnd
A18	LROW1	B18	LROW0
A19	Gnd	B19	Gnd
A20	LCOL4	B20	LCOL3
A21	Gnd	B21	Gnd
A22	LCOL2	B22	LCOL1
A23	Gnd	B23	Gnd
A24	LCOL0	B24	LDQB0
A25	Gnd	B25	Gnd
A26	LDQB1	B26	LDQB2
A27	Gnd	B27	Gnd
A28	LDQB3	B28	LDQB4
A29	Gnd	B29	Gnd
A30	LDQB5	B30	LDQB6
A31	Gnd	B31	Gnd
A32	LDQB7	B32	LDQB8
A33	Gnd	B33	Gnd
A34	LSCK	B34	LCMD
A35	Vcmos	B35	Vcmos
A36	SOUT	B36	SIN
A37	Vcmos	B37	Vcmos
A38	NC	B38	NC
A39	Gnd	B39	Gnd
A40	NC	B40	NC
A41	Vdd	B41	Vdd
A42	Vdd	B42	Vdd
A43	NC	B43	NC
A44	NC	B44	NC
A45	NC	B45	NC
A46	NC	B46	NC

Pin	Pin Name	Pin	Pin Name
A47	NC	B47	NC
A48	NC	B48	NC
A49	NC	B49	NC
A50	NC	B50	NC
A51	Vref	B51	Vref
A52	Gnd	B52	Gnd
A53	SCL	B53	SA0
A54	Vdd	B54	Vdd
A55	SDA	B55	SA1
A56	SVdd	B56	SVdd
A57	SWP	B57	SA2
A58	Vdd	B58	Vdd
A59	RSCK	B59	RCMD
A60	Gnd	B60	Gnd
A61	RDQB7	B61	RDQB8
A62	Gnd	B62	Gnd
A63	RDQB5	B63	RDQB6
A64	Gnd	B64	Gnd
A65	RDQB3	B65	RDQB4
A66	Gnd	B66	Gnd
A67	RDQB1	B67	RDQB2
A68	Gnd	B68	Gnd
A69	RCOL0	B69	RDQB0
A70	Gnd	B70	Gnd
A71	RCOL2	B71	RCOL1
A72	Gnd	B72	Gnd
A73	RCOL4	B73	RCOL3
A74	Gnd	B74	Gnd
A75	RRROW1	B75	RRROW0
A76	Gnd	B76	Gnd
A77	NC	B77	RRROW2
A78	Gnd	B78	Gnd
A79	RCTM	B79	NC
A80	Gnd	B80	Gnd
A81	RCTMN	B81	RCFMN
A82	Gnd	B82	Gnd
A83	RDQA0	B83	RCFM
A84	Gnd	B84	Gnd
A85	RDQA2	B85	RDQA1
A86	Gnd	B86	Gnd
A87	RDQA4	B87	RDQA3
A88	Gnd	B88	Gnd
A89	RDQA6	B89	RDQA5
A90	Gnd	B90	Gnd
A91	RDQA8	B91	RDQA7
A92	Gnd	B92	Gnd

**MR16R0824(6/8/C/G)AN1**  
**MR18R0824(6/8/C/G)AN1**

**Table 3: Module Connector Pad Description**

Signal	Pins	I/O	Type	Description
Gnd	A1, A3, A5, A7, A9, A11, A13, A15, A17, A19, A21, A23, A25, A27, A29, A31, A33, A39, A52, A60, A62, A64, A66, A68, A70, A72, A74, A76, A78, A80, A82, A84, A86, A88, A90, A92, B1, B3, B5, B7, B9, B11, B13, B15, B17, B19, B21, B23, B25, B27, B29, B31, B33, B39, B52, B60, B62, B64, B66, B68, B70, B72, B74, B76, B78, B80, B82, B84, B86, B88, B90, B92			Ground reference for RDRAM core and interface. 72 PCB connector pads.
LCFM	B10	I	RSL	Clock from master. Interface clock used for receiving RSL signals from the Channel. Positive polarity.
LCFMN	B12	I	RSL	Clock from master. Interface clock used for receiving RSL signals from the Channel. Negative polarity.
LCMD	B34	I	V <sub>CMOS</sub>	Serial Command used to read from and write to the control registers. Also used for power management.
LCOL4.. LCOL0	A20, B20, A22, B22, A24	I	RSL	Column bus. 5-bit bus containing control and address information for column accesses.
LCTM	A14	I	RSL	Clock to master. Interface clock used for transmitting RSL signals to the Channel. Positive polarity.
LCTMN	A12	I	RSL	Clock to master. Interface clock used for transmitting RSL signals to the Channel. Negative polarity.
LDQA8.. LDQA0	A2, B2, A4, B4, A6, B6, A8, B8, A10	I/O	RSL	Data bus A. A 9-bit bus carrying a byte of read or write data between the Channel and the RDRAM. LDQA8 is non-functional on modules with x16 RDRAM devices
LDQB8.. LDQB0	B32, A32, B30, A30, B28, A28, B26, A26, B24	I/O	RSL	Data bus B. A 9-bit bus carrying a byte of read or write data between the Channel and the RDRAM. LDQB8 is non-functional on modules with x16 RDRAM devices.
LROW2.. LROW0	B16, A18, B18	I	RSL	Row bus. 3-bit bus containing control and address information for row accesses.
LSCK	A34	I	V <sub>CMOS</sub>	Serial Clock input. Clock source used to read from and write to the RDRAM control registers.
NC	A16, B14, A38, B38, A40, B40, A43, B43, A44, B44, A45, B45, A46, B46, A47, B47, A48, B48, A49, B49, A50, B50, A77, B79			These pads are not connected. These 24 connector pads are reserved for future use.
RCFM	B83	I	RSL	Clock from master. Interface clock used for receiving RSL signals from the Channel. Positive polarity.
RCFMN	B81	I	RSL	Clock from master. Interface clock used for receiving RSL signals from the Channel. Negative polarity.
RCMD	B59	I	V <sub>CMOS</sub>	Serial Command Input. Pin used to read from and write to the control registers. Also used for power management.

**MR16R0824(6/8/C/G)AN1**  
**MR18R0824(6/8/C/G)AN1**

Signal	Pins	I/O	Type	Description
RCOL4.. RCOL0	A73, B73, A71, B71, A69	I	RSL	Column bus. 5-bit bus containing control and address information for column accesses.
RCTM	A79	I	RSL	Clock to master. Interface clock used for transmitting RSL signals to the Channel. Positive polarity.
RCTMN	A81	I	RSL	Clock to master. Interface clock used for transmitting RSL signals to the Channel. Negative polarity.
RDQA8.. RDQA0	A91, B91, A89, B89, A87, B87, A85, B85, A83	I/O	RSL	Data bus A. A 9-bit bus carrying a byte of read or write data between the Channel and the RDRAM. RDQA8 is non-functional on modules x16 RDRAM devices.
RDQB8.. RDQB0	B61, A61, B63, A63, B65, A65, B67, A67, B69	I/O	RSL	Data bus B. A 9-bit bus carrying a byte of read or write data between the Channel and the RDRAM. RDQB8 is non-functional on modules x16 RDRAM devices.
RROW2.. RROW0	B77, A75, B75	I	RSL	Row bus. 3-bit bus containing control and address information for row accesses.
RSCK	A59	I	V <sub>CMOS</sub>	Serial Clock input. Clock source used to read from and write to the RDRAM control registers.
SA0	B53	I	SV <sub>DD</sub>	Serial Presence Detect Address 0.
SA1	B55	I	SV <sub>DD</sub>	Serial Presence Detect Address 1.
SA2	B57	I	SV <sub>DD</sub>	Serial Presence Detect Address 2.
SCL	A53	I	SV <sub>DD</sub>	Serial Presence Detect Clock.
SDA	A55	I/O	SV <sub>DD</sub>	Serial Presence Detect Data (Open Collector I/O).
SIN	B36	I/O	V <sub>CMOS</sub>	Serial I/O for reading from and writing to the control registers. Attaches to SIO0 of the first RDRAM on the module.
SOUT	A36	I/O	V <sub>CMOS</sub>	Serial I/O for reading from and writing to the control registers. Attaches to SIO1 of the last RDRAM on the module.
SV <sub>DD</sub>	A56, B56			SPD Voltage. Used for signals SCL, SDA, SWE, SA0, SA1 and SA2.
SWP	A57	I	SV <sub>DD</sub>	Serial Presence Detect Write Protect (active high). When low, the SPD can be written as well as read.
V <sub>CMOS</sub>	A35, B35, A37, B37			CMOS I/O Voltage. Used for signals CMD, SCK, SIN, SOUT.
V <sub>dd</sub>	A41, A42, A54, A58, B41, B42, B54, B58			Supply voltage for the RDRAM core and interface logic.
V <sub>ref</sub>	A51, B51			Logic threshold reference voltage for RSL signals.

**MR16R0824(6/8/C/G)AN1**  
**MR18R0824(6/8/C/G)AN1**

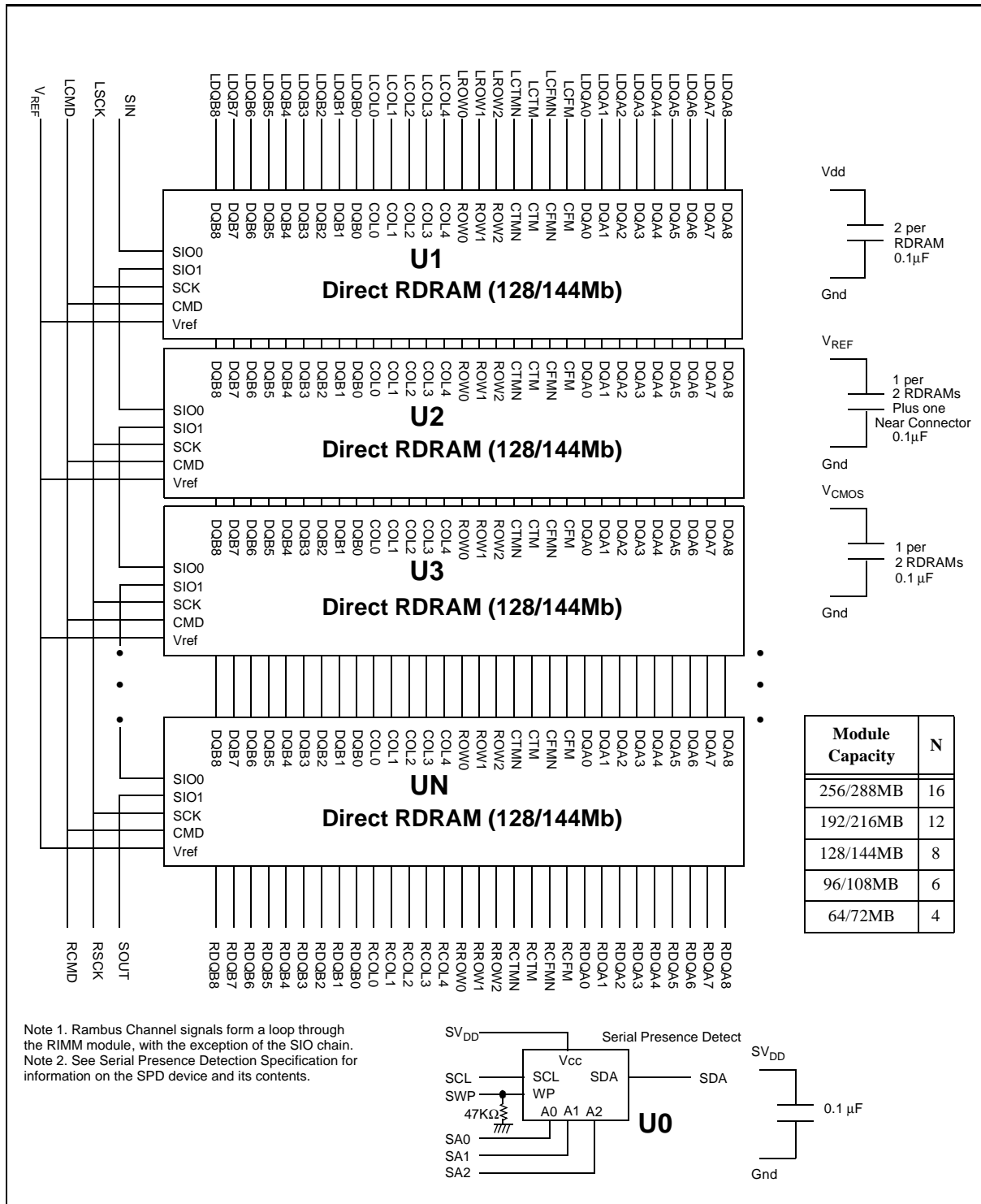

**Figure 2: RIMM Module Functional Diagram**

**MR16R0824(6/8/C/G)AN1**  
**MR18R0824(6/8/C/G)AN1**

**Absolute Maximum Ratings**

**Table 4: Absolute Maximum Ratings**

Symbol	Parameter	Min	Max	Unit
V <sub>L,ABS</sub>	Voltage applied to any RSL or CMOS signal pad with respect to Gnd	- 0.3	V <sub>DD</sub> + 0.3	V
V <sub>DD,ABS</sub>	Voltage on VDD with respect to Gnd	- 0.5	V <sub>DD</sub> + 1.0	V
T <sub>STORE</sub>	Storage temperature	- 50	100	°C
T <sub>PLATE</sub>	Plate temperature	-	92	°C

**DC Recommended Electrical Conditions**

**Table 5: DC Recommended Electrical Conditions**

Symbol	Parameter and Conditions	Min	Max	Unit
V <sub>DD</sub>	Supply voltage	2.50 - 0.13	2.50 + 0.13	V
V <sub>CMOS</sub>	CMOS I/O power supply at pad for 2.5V controllers: CMOS I/O power supply at pad for 1.8V controllers:	V <sub>DD</sub> 1.8 - 0.1	V <sub>DD</sub> 1.8 + 0.2	V V
V <sub>REF</sub>	Reference voltage	1.4 - 0.2	1.4 + 0.2	V
V <sub>SPD</sub>	Serial Presence Detector- Positive power supply	2.2	3.6	V
V <sub>IL</sub>	RSL input low voltage	V <sub>REF</sub> - 0.5	V <sub>REF</sub> - 0.2	V
V <sub>IH</sub>	RSL input high voltage	V <sub>REF</sub> + 0.2	V <sub>REF</sub> + 0.5	V
V <sub>IL,CMOS</sub>	CMOS input low voltage	- 0.3	0.5V <sub>CMOS</sub> - 0.25	V
V <sub>IH,CMOS</sub>	CMOS input high voltage	0.5V <sub>CMOS</sub> + 0.25	V <sub>CMOS</sub> + 0.3	V
V <sub>OL,CMOS</sub>	CMOS output low voltage @ I <sub>OL,CMOS</sub> = 1mA		0.3	V
V <sub>OH,CMOS</sub>	CMOS output high voltage @ I <sub>OH,CMOS</sub> = -0.25mA	V <sub>CMOS</sub> - 0.3		V
I <sub>REF</sub>	V <sub>REF</sub> current @ V <sub>REF,MAX</sub>	-10 x no. RDRAMs <sup>a</sup>	10 x no. RDRAMs <sup>a</sup>	μA
I <sub>SCK,CMD</sub>	CMOS input leakage current @ (0 ≤ V <sub>CMOS</sub> ≤ V <sub>DD</sub> )	-10 x no. RDRAMs <sup>a</sup>	10 x no. RDRAMs <sup>a</sup>	μA
I <sub>SIN,SOUT</sub>	CMOS input leakage current @ (0 ≤ V <sub>CMOS</sub> ≤ V <sub>DD</sub> )	-10.0	10.0	μA

a. The table below shows the number of 128Mb or 144Mb RDRAM devices contained in a RIMM module of listed memory storage capacity.

**Table 6: RIMM Module Capacity and Number of RDRAM device**

RIMM Module Capacity	256/288MB	192/216MB	128/144MB	96/108MB	64/72MB
Number of 128Mb or 144Mb RDRAM devices	16	12	8	6	4

**MR16R0824(6/8/C/G)AN1**  
**MR18R0824(6/8/C/G)AN1**

**RIMM Module Current Profile**

**Table 7 : RIMM Module Current Profile**

I <sub>DD</sub>	RIMM Module Capacity		256/288MB	192/216MB	128/144MB	96/108MB	64/72MB	Unit
	Number of 128/144Mb RDRAMs		16	12	8	6	4	
	RIMM Module power conditions <sup>a</sup>	Freq.	Max	Max	Max	Max	Max	
I <sub>DD1</sub>	One RDRAM in Read <sup>b</sup> , balance in NAP mode	-800	550/580	540/570	520/550	510/540	510/540	mA
		-711	510/540	500/530	480/510	470/500	470/500	mA
		-600	460/480	450/470	430/450	420/440	420/440	mA
I <sub>DD2</sub>	One RDRAM in Read <sup>b</sup> , balance in Standby mode	-800	2070/2100	1650/1680	1230/1260	1020/1050	810/840	mA
		-711	1950/1980	1550/1580	1150/1180	950/980	750/780	mA
		-600	1750/1770	1390/1410	1030/1050	850/870	670/690	mA
I <sub>DD3</sub>	One RDRAM in Read <sup>b</sup> , balance in Active mode	-800	2970/3000	2310/2340	1650/1680	1320/1350	990/1020	mA
		-711	2780/2810	2160/2190	1540/1570	1230/1260	920/950	mA
		-600	2500/2520	1940/1960	1380/1400	1100/1120	820/840	mA
I <sub>DD4</sub>	One RDRAM in Write, balance in NAP mode	-800	640/690	620/670	610/660	600/650	590/640	mA
		-711	590/640	570/630	560/610	550/600	540/600	mA
		-600	520/560	500/550	490/530	480/520	470/520	mA
I <sub>DD5</sub>	One RDRAM in Write, balance in Standby mode	-800	2150/2200	1730/1780	1310/1360	1100/1150	890/940	mA
		-711	2030/2080	1630/1680	1230/1280	1030/1080	830/880	mA
		-600	1810/1850	1450/1490	1090/1130	910/950	730/770	mA
I <sub>DD6</sub>	One RDRAM in Write, balance in Active mode	-800	3050/3100	2390/2440	1730/1780	1400/1450	1070/1120	mA
		-711	2850/2910	2230/2290	1610/1670	1300/1360	990/1050	mA
		-600	2560/2600	2000/2040	1440/1480	1160/1200	880/920	mA

a. Actual power will depend on individual RDRAM component specifications, memory controller and usage patterns. Power does not include Refresh Current.

b. I/O current is a function of the % of 1's, to add I/O power for 50% 1's for a X16 need to add 257mA or 290mA for X18 ECC module for the following:  
 $V_{DD} = 2.5V$ ,  $V_{TERM} = 1.8V$ ,  $V_{REF} = 1.4V$  and  $V_{DIL} = V_{REF} - 0.5V$ .

**MR16R0824(6/8/C/G)AN1**  
**MR18R0824(6/8/C/G)AN1**

**AC Electrical Specifications**

**Table 8: AC Electrical Specifications**

Symbol	Parameter and Conditions	Min	Typ	Max	Unit
Z <sub>L</sub>	Module Impedance of RSL Signals	25.2	28	30.8	Ω
Z <sub>UL-CMOS</sub>	Module Impedance of SCK and CMOS signals	23.8	28	32.2	Ω
T <sub>PD</sub>	Propagation Delay variation of RSL signals. Average clock delay from finger to finger of all RSL clock nets (CTM, CTMN, CFM, and CFMN)	-		See Table10 <sup>a,b</sup>	ns
ΔT <sub>PD</sub>	Propagation delay variation of RSL signals with respect to T <sub>PD</sub> <sup>b,c</sup> for 4, 6, 8, and 12 device modules	-21		21	ps
	Propagation delay variation of RSL signals with respect to T <sub>PD</sub> <sup>b,c</sup> for 16 device modules	-24		24	ps
ΔT <sub>PD-CMOS</sub>	Propagation delay variation of SCK signals with respect to an average clock delay <sup>b</sup>	-250		250	ps
ΔT <sub>PD-SCK,CMD</sub>	Propagation delay variation of CMD signals with respect to SCK signal	-200		200	ps
V <sub>α</sub> /V <sub>IN</sub>	Attenuation Limit			See Table10 <sup>a</sup>	%
V <sub>XF</sub> /V <sub>IN</sub>	Forward crosstalk coefficient (300ps input rise time @ 20%-80%)			See Table10 <sup>a</sup>	%
V <sub>XB</sub> /V <sub>IN</sub>	Backward crosstalk coefficient (300ps input rise time @ 20%-80%)			See Table10 <sup>a</sup>	%

- a. Table 10 lists parameters and specifications for different storage capacity RIMM Modules that use 128Mb or 144Mb RDRAM devices.  
b. T<sub>PD</sub> or Average clock delay is defined as the average delay from finger to finger of all RSL clock nets (CTM, CTMN, CFM, and CFMN).  
c. If the RIMM module meets the following specification, then it is compliant to the specification. If the RIMM module does not meet these specifications, then the specification can be adjusted by the "Adjusted ΔT<sub>PD</sub> Specification" table below.

**Adjusted ΔT<sub>PD</sub> Specification**

**Table 9: Adjusted ΔT<sub>PD</sub> Specification**

Symbol	Parameter and Conditions	Adjusted Min/Max	Absolute Min / Max		Unit
ΔT <sub>PD</sub>	Propagation delay variation of RSL signals with respect to T <sub>PD</sub> for 4, 6, and 8 device modules	+/-[17+(18*N*ΔZ0)] <sup>a</sup>	-30	30	ps
	Propagation delay variation of RSL signals with respect to T <sub>PD</sub> for 12 device modules	+/-[20+(18*N*ΔZ0)] <sup>a</sup>	-40	40	ps
	Propagation delay variation of RSL signals with respect to T <sub>PD</sub> for 16 device modules	+/-[24+(18*N*ΔZ0)] <sup>a</sup>	-50	50	ps

- a. Where: N = Number of RDRAM devices installed on the RIMM module  
ΔZ0 = delta Z0% = (max Z0 - min Z0)/(min Z0)  
(max Z0 and min Z0 are obtained from the loaded (high impedance) impedance coupons of all RSL layers on the modules)

**MR16R0824(6/8/C/G)AN1**  
**MR18R0824(6/8/C/G)AN1**

**AC Electrical Specifications for RIMM Modules**

**Table 10: AC Electrical Specifications for RIMM Modules**

Symbol	RIMM Module Capacity		256/288MB	192/216MB	128/144MB	96/108MB	64/72MB	Unit	
	Number of 128/144Mb RDRAMs		16	12	8	6	4		
	Parameter and Condition for RIMM Modules	Freq.	Max	Max	Max	Max	Max		
T <sub>PD</sub>	Propagation Delay, all RSL signals		-800	2.11	1.76	1.56	1.40	1.28	ns
			-711	2.11	1.76	1.56	1.40	1.28	ns
			-600	2.11	1.76	1.56	1.40	1.28	ns
V <sub>α</sub> /V <sub>IN</sub>	Attenuation Limit		-800	25.0	20.0	16.0	14.0	12.0	%
			-711	25.0	20.0	16.0	14.0	12.0	%
			-600	18.5	15.5	12.5	11.5	10.5	%
V <sub>XF</sub> /V <sub>IN</sub>	Forward crosstalk coefficient (300ps input rise time @ 20%-80%)		-800	8.0	6.0	4.0	3.0	2.0	%
			-711	8.0	6.0	4.0	3.0	2.0	%
			-600	8.0	6.0	4.0	3.0	2.0	%
V <sub>XB</sub> /V <sub>IN</sub>	Backward crosstalk coefficient (300ps input rise time @ 20%-80%)		-800	2.5	2.3	2.0	1.8	1.5	%
			-711	2.5	2.3	2.0	1.8	1.5	%
			-600	2.5	2.3	2.0	1.8	1.5	%
R <sub>DC</sub>	DC Resistance Limit		-800	1.2	1.1	0.8	0.7	0.6	Ω
			-711	1.2	1.1	0.8	0.7	0.6	Ω
			-600	1.2	1.1	0.8	0.7	0.6	Ω

**MR16R0824(6/8/C/G)AN1**  
**MR18R0824(6/8/C/G)AN1**

**Physical Dimensions -1 ( For PCB )**

The following defines the RIMM module dimensions. All units are in millimeters with inches in brackets [ ], where appropriate. The dimensions without tolerance specification use the default tolerance of  $\pm 0.127[\pm 0.005]$ .

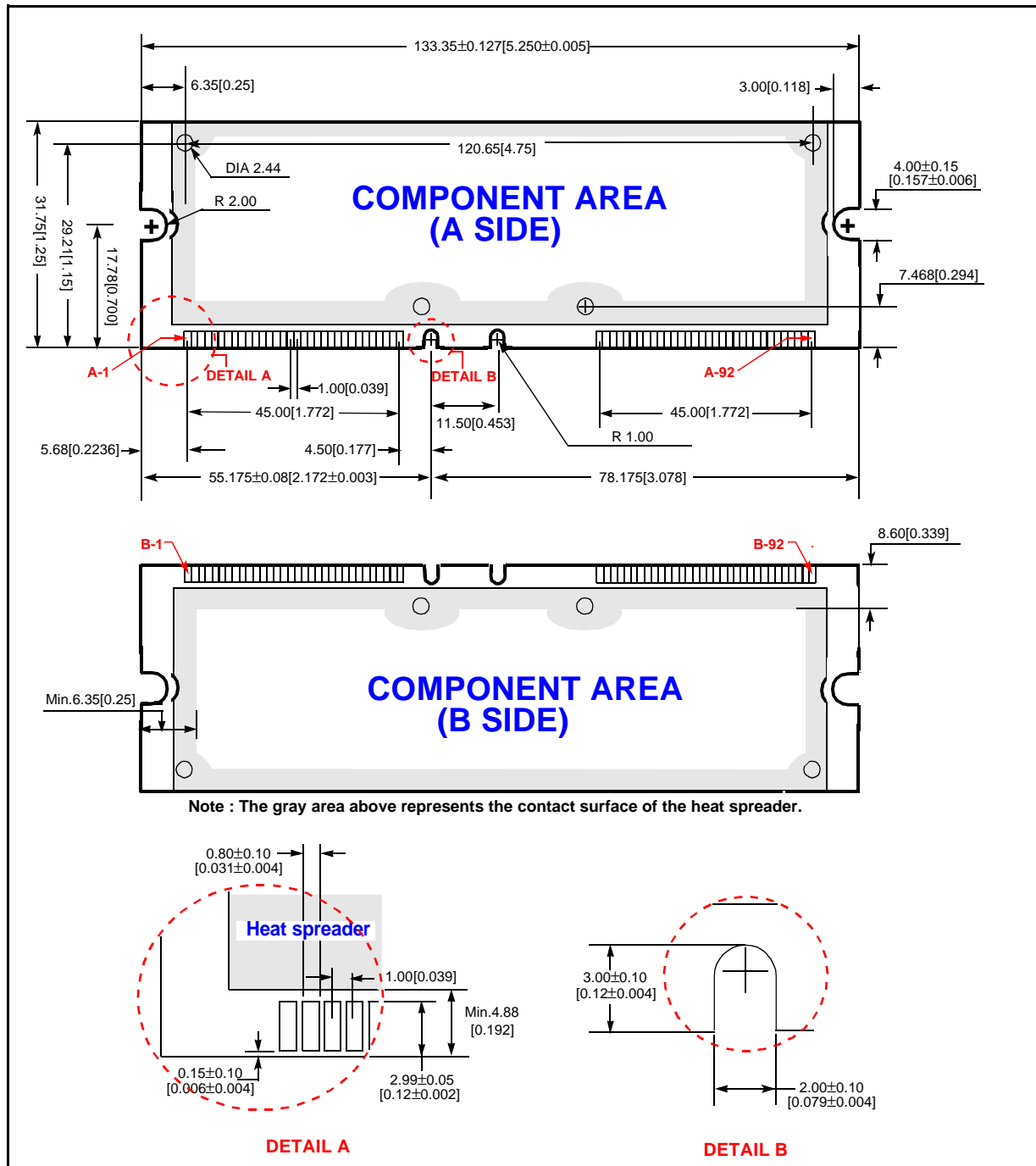
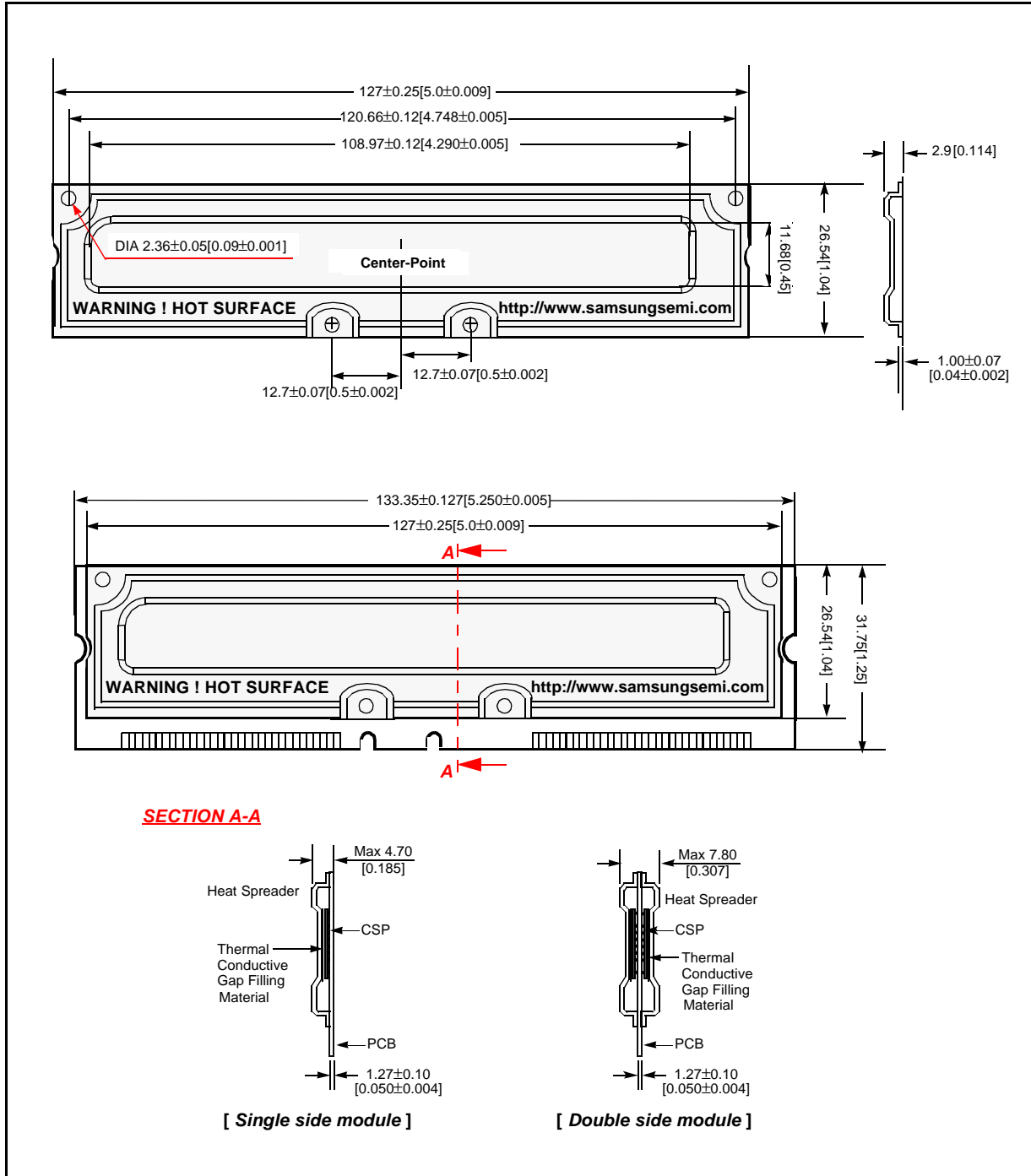

Figure 3: RIMM Module PCB Physical Dimensions

**MR16R0824(6/8/C/G)AN1**  
**MR18R0824(6/8/C/G)AN1**

**Physical Dimensions -2 ( For Heat Spreader )**

The following defines the RIMM module dimensions. All units are in millimeters with inches in brackets[ ], where appropriate. The dimensions without tolerance specification use the default tolerance of  $\pm 0.127[\pm 0.005]$ .



**Figure 4: Heat Spreader Physical Dimensions**

**MR16R0824(6/8/C/G)AN1**  
**MR18R0824(6/8/C/G)AN1**

**Standard RIMM Module Marking**

The RIMM modules available from Samsung are marked like Figure 5 below. This marking also assists users to specify and verify if the correct RIMM modules are installed in their systems. In the diagram, a label is shown attached to the

RIMM module's heat spreader. Information contained on the label is specific to the RIMM module and provides RDRAM information without requiring removal of the RIMM module's heat spreader.

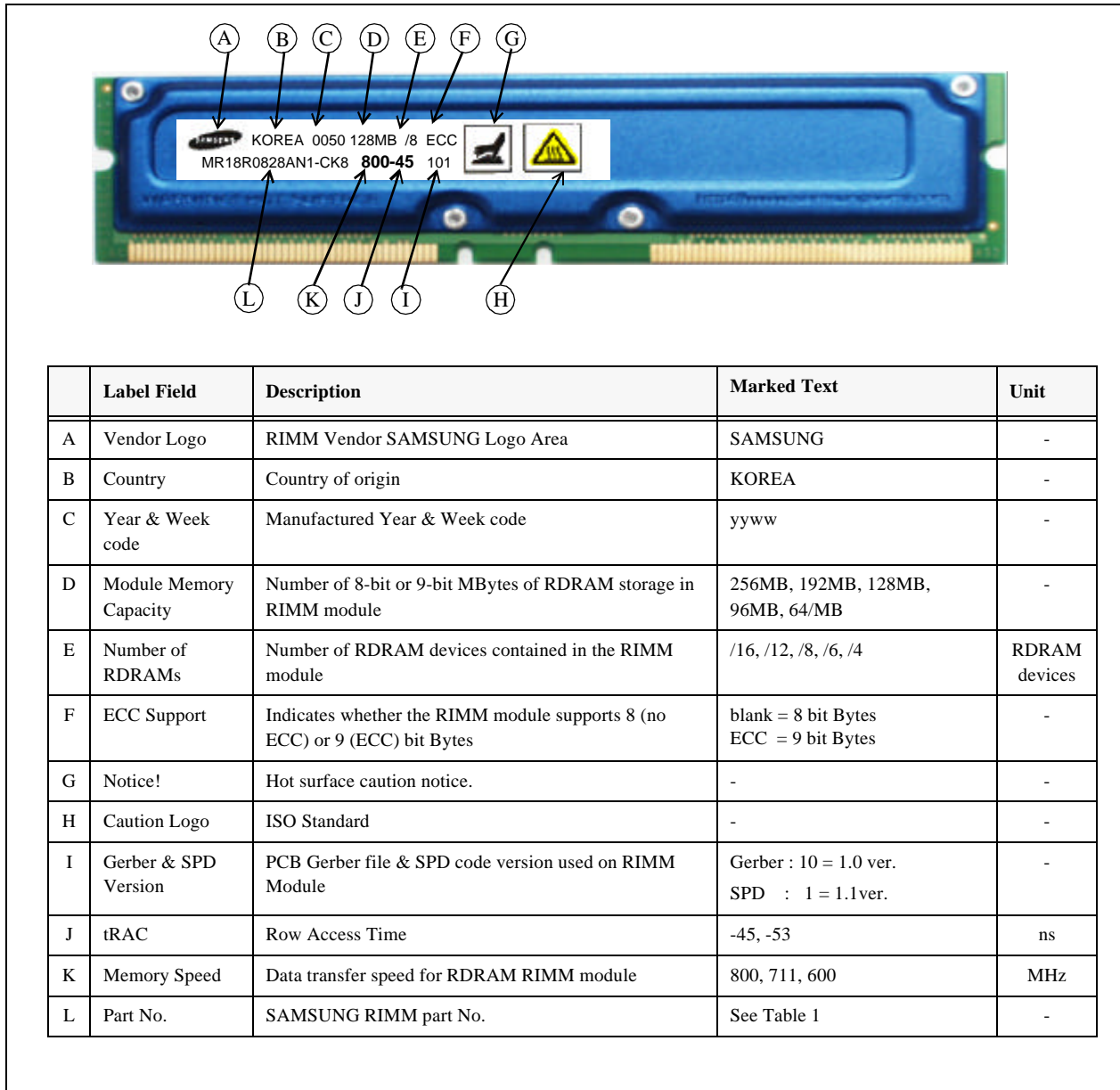

**Figure 5: RIMM Marking Example**

**MR16R0824(6/8/C/G)AN1**  
**MR18R0824(6/8/C/G)AN1**

---

**Table Of Contents**

Overview . . . . . 1  
Features . . . . . 1  
Key Timing Parameters/Part Numbers . . . . . 1  
Module Pad Numbers and Signal Names . . . . . 2  
Module Connector Pad Description . . . . . 3 - 4  
RIMM Module Functional Diagram . . . . . 5  
Absolute Maximum Ratings . . . . . 6  
DC Recommended Electrical Conditions . . . . . 6  
RIMM Module Supply Current Profile . . . . . 7  
AC Electrical Specifications . . . . . 8 - 9  
Physical Dimensions -1 ( For PCB ) . . . . . 10  
Physical Dimensions -2 ( For Heat Spreader) . . . . . 11  
Standard RIMM Module Marking . . . . . 12

Copyright © October 2000, Samsung Electronics.  
All rights reserved.

Direct Rambus and Direct RDRAM, SO-RIMM and RIMM are trademarks of Rambus Inc. Rambus, RDRAM, and the Rambus Logo are registered trademarks of Rambus Inc.

This document contains advanced information that is subject to change by Samsung Electronics without notice

Document Version 1.1

Samsung Electronics Co. Ltd.  
San #24 Nongseo-Ri, Kiheung-Eup Yongin-City  
Kyunggi-Do, KOREA

Telephone: 82-331-209-3868  
Fax: 82-2-760-7990  
<http://www.intl.samsungsemi.com>