

128 x 64 Graphic LCD

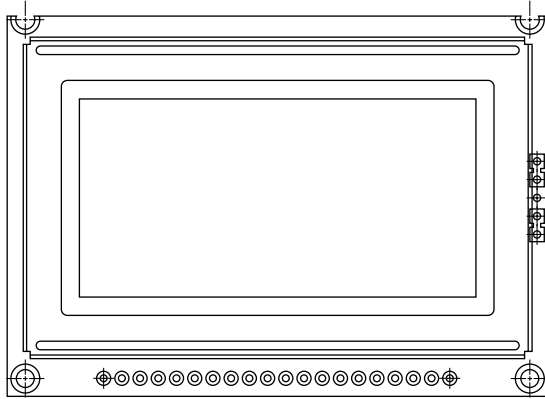

FEATURES

- Type: Graphic
- Display format: 128 x 64 dots
- Built-in controller: Samsung KS 0107/KS 0108 (or equivalent)
- Duty cycle: 1/64
- + 5 V power supply
- N.V. built-in
- Chinese version: LCD-128H064S
- Compliant to RoHS directive 2002/95/EC

RoHS
COMPLIANT

MECHANICAL DATA		
ITEM	STANDARD VALUE	UNIT
Module Dimension	75.0 x 52.7	mm
Viewing Area	60.0 x 32.6	
Dot Size	0.39 x 0.39	
Dot Pitch	0.43 x 0.43	
Mounting Hole	70.0 x 49.7	
Character Size	N/a	

ABSOLUTE MAXIMUM RATINGS					
ITEM	SYMBOL	STANDARD VALUE			UNIT
		MIN.	TYP.	MAX.	
Power Supply	V_{DD} to V_{SS}	4.75	5.0	5.25	V
Input Voltage	V_I	- 0.3	-	V_{DD}	

Note

- $V_{SS} = 0$ V, $V_{DD} = 5.0$ V

ELECTRICAL CHARACTERISTICS						
ITEM	SYMBOL	CONDITION	STANDARD VALUE			UNIT
			MIN.	TYP.	MAX.	
Input Voltage	V_{DD}	L level	$0.7 V_{DD}$	-	V_{DD}	V
	V_{IO}	H level	0	-	$0.3 V_{DD}$	
Supply Current	I_{DD}	$V_{DD} = +5$ V	-	4.0	5.2	mA
Recommended LC Driving Voltage for Normal Temperature Version Module	V_{DD} to V_0	- 20 °C	9.9	10.4	10.9	V
		0 °C	9.7	10.2	10.7	
		25 °C	7.5	8.0	8.5	
		50 °C	8.6	9.1	9.6	
		70 °C	8.4	8.9	9.4	
LED Forward Voltage	V_F	25 °C	-	4.2	4.6	V
LED Forward Current - Edge	I_F	25 °C	-	100	150	mA
EL Power Supply Current	I_{EL}	$V_{EL} = 110$ V _{AC} , 400 Hz	-	-	5.0	mA

OPTIONS									
PROCESS COLOR						BACKLIGHT			
TN	STN Gray	STN Yellow	STN Blue	FSTN B&W	STN Color	None	LED	EL	CCFL
	x	x	x			x	x	x	x

For detailed information, please see the "Product Numbering System" document.

INTERFACE PIN FUNCTION		
PIN NO.	SYMBOL	FUNCTION
1	V _{DD}	Power supply (+ 5 V)
2	GND	Power supply (ground)
3	V ₀	Contrast adjustment
4	DB0	Data bus line
5	DB1	Data bus line
6	DB2	Data bus line
7	DB3	Data bus line
8	DB4	Data bus line
9	DB5	Data bus line
10	DB6	Data bus line
11	DB7	Data bus line
12	CS1	Chip select for IC1
13	CS2	Chip select for IC2
14	R _{ST}	Reset signal
15	R/W	Data read/write
16	D/I	Data/instruction
17	E	Enable signal
18	V _{EE}	Negative voltage output
19	A	Power supply for LED (+ 4.2 V)
20	K	Power supply for LED (0 V)

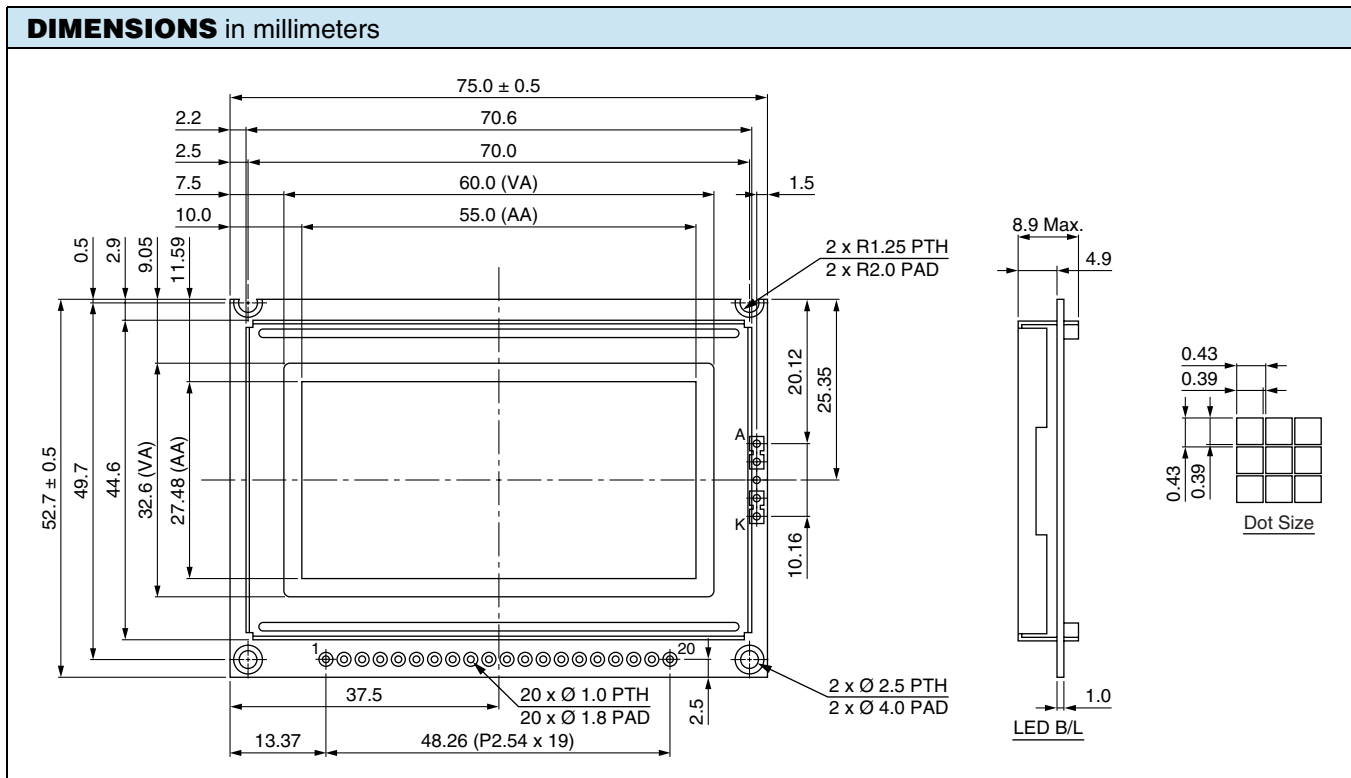



Disclaimer

All product specifications and data are subject to change without notice.

Vishay Intertechnology, Inc., its affiliates, agents, and employees, and all persons acting on its or their behalf (collectively, "Vishay"), disclaim any and all liability for any errors, inaccuracies or incompleteness contained herein or in any other disclosure relating to any product.

Vishay disclaims any and all liability arising out of the use or application of any product described herein or of any information provided herein to the maximum extent permitted by law. The product specifications do not expand or otherwise modify Vishay's terms and conditions of purchase, including but not limited to the warranty expressed therein, which apply to these products.

No license, express or implied, by estoppel or otherwise, to any intellectual property rights is granted by this document or by any conduct of Vishay.

The products shown herein are not designed for use in medical, life-saving, or life-sustaining applications unless otherwise expressly indicated. Customers using or selling Vishay products not expressly indicated for use in such applications do so entirely at their own risk and agree to fully indemnify Vishay for any damages arising or resulting from such use or sale. Please contact authorized Vishay personnel to obtain written terms and conditions regarding products designed for such applications.

Product names and markings noted herein may be trademarks of their respective owners.