

PN9273/74 Very Low noise Microwave Down-converter

For Low Noise MW Radar Sources, a very low noise reference source is required in the offset range the 1Hz to 10kHz from the carrier. Unfortunately, there is no wide-band and high resolution DC FM synthesizer available for such a low noise and building it would cost too much. Then the only solution is to mix the DUT signal with clean fixed frequencies, providing an IF signal in the range of the PN9000 RF base system.

Operating Diagram

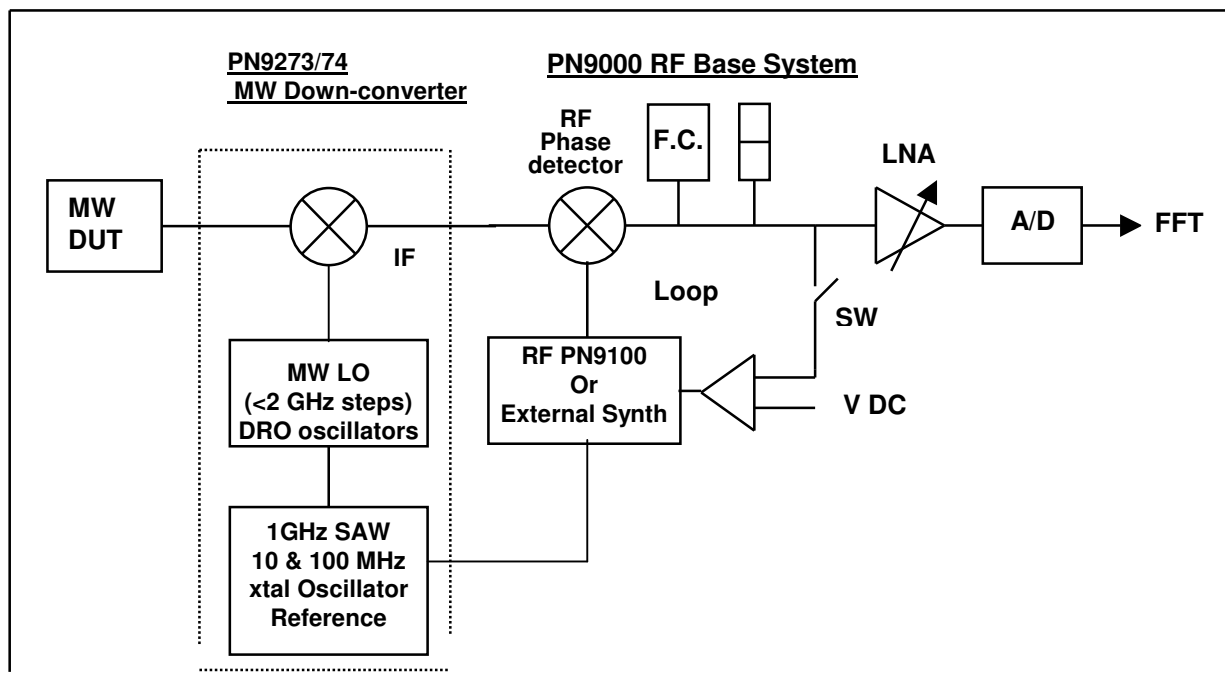

The PN9273/74 includes Microwave DROs phase locked on three very low noise reference oscillators : a 1GHz SAW oscillator, a 100 MHz crystal oscillator and a 10 MHz crystal oscillator . These three oscillators are locked together in order to provide the lowest noise close-in and far away from the carrier.

Just setting, at the software request, the Microwave DUT frequency value, the closest LO frequency will be selected and the RF reference source will be automatically tuned on the IF frequency value. Then measurement process is as simple as it is for RF source measurement (see PN9000 base system).

Microwave PN9273/74 VLN Down-converter Specifications

- Input Frequency range, PN9273** : 1.7 to 18 GHz
PN9274 : 1.7 to 26.5 GHz
- MW Signal Input Level** : - 10 to + 0 dBm
 -10 dBm to -20dBm with RF Base system amplifiers
- LO Fixed Frequencies, PN9273** : 2.0, 3.8, 4.2, 7.6, 8.4, 11.4, 12.6, 15.2 and 16.8 GHz
PN9274 : Same as above + 19.0, 21.0, 22.8 and 25.2 GHz
 Depending on the DUT input signal, the right LO frequency will be selected manually or automatically.
- LO fixed Frequencies Output Level** : All > + 7 dBm
- IF Output Frequency/Level** : 50 MHz to 1.8 GHz / -10 to 0 dBm
- Spurious response** : <- 50 dBc from 1 Hz to 1 kHz offset
 <- 80 dBc above 1 KHz offset
- Residual Phase Noise** : Down-converter residual noise is the noise of the fixed LOs.
Typical values (Guaranteed +5dB) :

Offset	2 GHz	3.8/4.2 GHz	7.6/8.4 GHz	11.4/12.6 GHz	15.2/16.8 GHz	19.0/21.0 GHz	22.8/25.2 GHz
1 Hz	- 64	- 58	- 52	- 49	- 46	- 44	- 42
10 Hz	- 92	- 86	- 80	- 77	- 74	- 72	- 70
100 Hz	- 108	- 102	- 96	- 93	- 90	- 88	- 86
1 KHz	- 132	- 126	- 120	- 117	- 114	- 112	- 110
10 KHz	- 144	- 138	- 132	- 129	- 126	- 124	- 122
100 KHz	- 145	- 139	- 133	- 130	- 127	- 125	- 123
1 MHz	- 160	- 152	- 146	- 143	- 140	- 138	- 136
10 MHz	- 160	-163	- 157	- 153	- 151	- 149	- 147