

This device is an advanced direct conversion receiver for operation up to 470MHz. The design is based on the SL6609A but is specifically designed for use in very small pagers i.e. credit card sized, where local oscillator re-radiation is a problem. This design has overcome this difficulty.

The device also includes a 1 volt regulator capable of sourcing up to 5mA, a battery flag and the facility of incorporating a more complex post detection filter off-chip. Both battery flag and data outputs have open collector outputs to ease their interface with other devices.

Adjacent channel rejection is provided using tuneable gyrator filters. To assist operation in the presence of large interfering signals both RF and audio AGC functions are provided.

FEATURES

- Very low power operation - typ 3.0mW
- Superior sensitivity of -130dBm
- Operation at wide range of paging data rates
512, 1200, 2400 baud
- Small package offering SSOP
- Excellent performance of LO Rejection

APPLICATIONS

- Credit card pagers
- Watch pagers
- Small form factor pagers i.e. PCMCIA

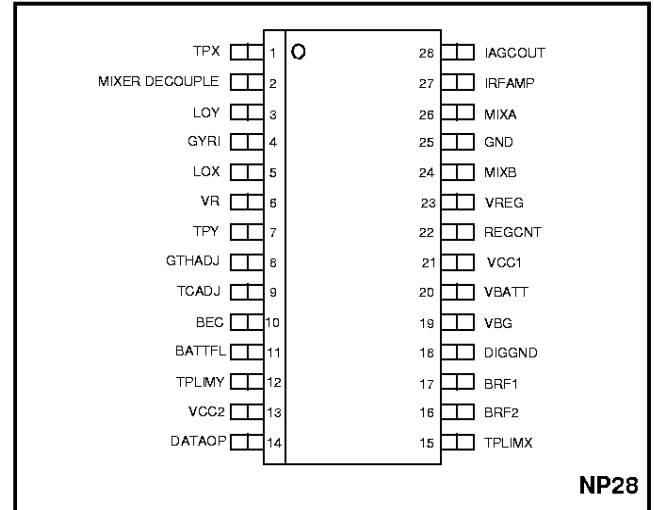

Fig.1 Pin connections

ABSOLUTE MAXIMUM RATINGS

Supply voltage	6V
Storage temperature	-55°C to +150°C
Operating temperature	-20°C to +70°C

ORDERING INFORMATION

- SL6610 / KG / NPDS - SSOP devices in anti-static sticks
- SL6610 / KG / NPDE - SSOP devices in tape and reel

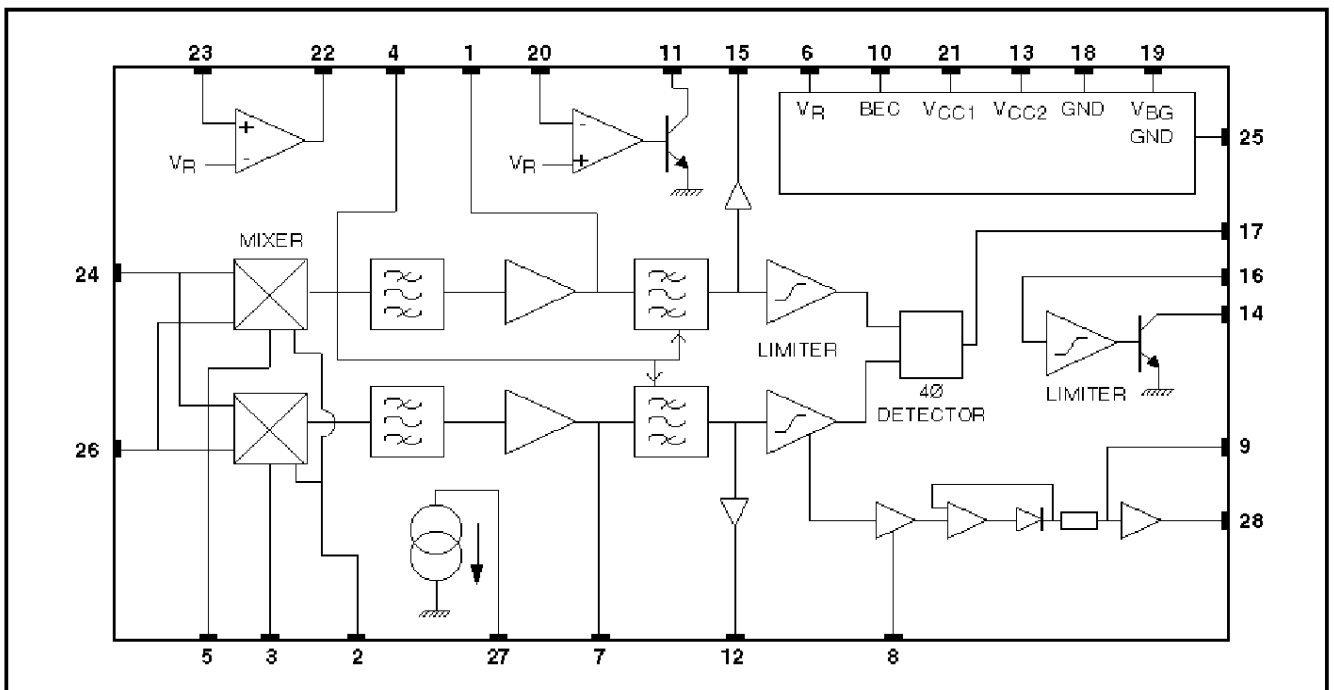

Fig.2 Block diagram of SL6610

SL6610

ELECTRICAL CHARACTERISTICS

These characteristics are guaranteed over the following conditions unless otherwise stated:

Tamb = 25 °C, VCC1 = 1.3V, VCC2 = 2.7V

Characteristics	Pin	Value			Units	Comments
		Min	Typ	Max		
VCC1 - Supply voltage	21	0.95	1.3	2.8	V	VCC1 ≤ VCC2 - 0.7 volts
VCC2 - Supply voltage	13	1.8	2.7	3.5	V	
ICC1 - Supply current	21,27,28		1.5	1.8	mA	Includes IRF. Does not include regulator supply. Audio AGC inactive Batt flag & Data O/P high Pin 27 voltage: 0.3 - 1.3V
ICC2 - Supply current	11,13,14		550	700	μA	
Power down ICC1	21,27,28			1	μA	
Power down ICC2	11,13,14			8	μA	
1 volt regulator	23	0.95	1.0	1.05	V	I Load = 3mA. Ext PNP. β ≥ 100, V _{CE} = 0.1 volt
Band gap voltage reference	19	1.15	1.21	1.27	V	VCC1 > 1.1V
Band gap current source	19			20	μA	
Voltage reference	6	0.93	1.0	1.07	V	
Voltage reference sink/source	6			10	μA	
1 volt regulator load current		0.25	3	5	mA	
Turn on Time			5		ms	
Turn off Time			1		ms	Fall to 10% of steady state current C _{BG} and C _{VR} = 2.2μF
Detector output current	17		+/-4		μA	
RF current source						
Current Source (IRF)	27	400	500	600	μA	Pin 27 voltage: 0.3 - 1.3V
Decoder						
Sensitivity		40			μVrms	Signal injected at TPX and TPY B.E.R. ≤ 1 in 30 5KHz deviation @ 1200 bits/sec BRF capacitor = 1nF
Output mark space ratio	14	7:9		9:7		
Data O/P Sink Current	14	100		500	μA	Output logic low
Data O/P Leakage Current	14			1.0	μA	Output logic high

ELECTRICAL CHARACTERISTICS

These characteristics are guaranteed over the following conditions unless otherwise stated:

Tamb = 25°C, VCC1 = 1.3V, VCC2 = 2.7V

Characteristics	Pin	Value			Units	Comments
		Min	Typ	Max		
Battery Economy						
Input logic high	10	(V _{CC2} - 0.3)			V	Powered Up
Input logic low	10			0.3	V	Powered Down
Input current	10		0.05	1	µA	Powered Up
Input current	10		6	8	µA	Powered down transient initial
Battery Flag Input						
Input current	20			1	µA	
Battery Flag Output						
Battfl Sink Current	11	50		500	µA	(VBATT-VR) > 20mV
Battfl leakage current	11			1	µA	(VBATT-VR) < -20mV
Mixers						
Gain to "IF Test"		34		41	dB	LO inputs driven in parallel with 50mVRMS @ 50MHz. IF = 2kHz
RF input impedance	24, 26					See Figs.8a, 8b
LO input impedance	3, 5					See Fig.9
LO DC bias voltage	3, 5				V	Equal to Pin 21 (VCC1)
Audio AGC						
Max Audio AGC Sink Current	28	45	65	85	µA	

RECEIVER CHARACTERISTICS (Demonstration board)

Measurement conditions unless stated V_{CC1} = 1.3V, V_{CC2} = 2.7V, LNA = 18dB Power Gain, 2dB Noise figure,

Carrier frequency 153MHz, BER 1 in 30, Tamb = 25°C

(TPx/TPy typically:- 160mV_{pp} ± 10% for -73dBm RF input to the LNA)

Characteristics	Pin	Value			Units	Comments
		Min	Typ	Max		
Sensitivity		-130	-128	-125	dBm	1200 bps Δf = 4kHz LO = -18dBm
Intermodulation		52	56		dB	1200 bps Δf = 4kHz LO = -18dBm
Adjacent channel		68	73		dB	1200 bps Δf = 4kHz LO = -18dBm Channel spacing 25kHz
Centre frequency acceptance			+/-2.3		kHz	1200 bps Δf = 4kHz LO = -18dBm
Deviation acceptance			+/-2.2		kHz	1200 bps Δf = 4kHz LO = -18dBm

SL6610

RECEIVER CHARACTERISTICS (Demonstration board)

Measurement conditions unless stated $V_{CC1} = 1.3V$, $V_{CC2} = 2.7V$, LNA = 20dB Power Gain, 2dB Noise figure,

Carrier frequency 282MHz, BER 1 in 30, $T_{amb} = 25^{\circ}C$

(TPx/TPy typically:- $160mV_{pp} \pm 10\%$ for -73dBm RF input to the LNA)

Characteristics	Pin	Value			Units	Comments
		Min	Typ	Max		
Sensitivity		-130	-128 -125.5	-125 -122	dBm dBm	1200 bps $\Delta f = 4kHz$ 2400 bps $\Delta f = 4.5kHz$ LO = -15dBm
Intermodulation (IP3)		52 49	56 53.5		dB	1200 bps $\Delta f = 4kHz$ 2400 bps $\Delta f = 4.5kHz$ LO = -15dBm
Intermodulation (IP2)		47	52		dB	1200 bps $\Delta f = 4kHz$ LO = -15dBm
Adjacent channel		67 64	72.5 69.5		dB	1200 bps $\Delta f = 4kHz$ 2400 bps $\Delta f = 4.5kHz$ LO = -15dBm Channel spacing 25kHz
Centre frequency acceptance		+/-1.9	+/-2.3 +/-2		kHz	1200 bps $\Delta f = 4kHz$ 2400 bps $\Delta f = 4.5kHz$ LO = -15dBm
Deviation acceptance			+/-2.2 +/-2		kHz	1200 bps $\Delta f = 4kHz$ 2400 bps $\Delta f = 4.5kHz$ LO = -15dBm

RECEIVER CHARACTERISTICS

Measurement conditions unless stated $V_{CC1} = 1.3V$, $V_{CC2} = 2.7V$, LNA = 22dB Power Gain, 2dB Noise figure,

Carrier frequency 470MHz, BER 1 in 30, $T_{amb} = 25^{\circ}C$

(TPx/TPy typically:- $140mV_{pp} \pm 10\%$ for -73dBm RF input to the LNA)

Characteristics	Pin	Value			Units	Comments
		Min	Typ	Max		
Sensitivity		-128	-126	-123	dBm	1200 bps $\Delta f = 4kHz$ LO = -15dBm
Intermodulation		50	55.5		dB	1200 bps $\Delta f = 4kHz$ LO = -15dBm
Adjacent channel		67	72.5		dB	1200 bps $\Delta f = 4kHz$ LO = -15dBm Channel spacing 25kHz
Centre frequency acceptance			+/- 2.3		kHz	1200 bps $\Delta f = 4kHz$ LO = -15dBm
Deviation acceptance			+/- 2.2		kHz	1200 bps $\Delta f = 4kHz$ LO = -15dBm

RECEIVER CHARACTERISTICS (Demonstration board)

Measurement conditions unless stated LNA = 18dB Power Gain, 2dB Noise figure,

Carrier frequency 282MHz, BER 1 in 30, Tamb = 0 to 45°C, Vcc2 = 2.7V, Vcc1 = 1.2V to 1.6V

(TPx/TPy typically:- 120mV_{pp} ± 10% for -73dBm RF input to the LNA)

Characteristics	Pin	Value			Units	Comments
		Min	Typ	Max		
Sensitivity (Desense from 25°C, Vcc1 = 1.3V)				1.5	dB	1200 bps Δf = 4kHz LO = -15dBm
Intermodulation (IP3)		53	58		dB	1200 bps Δf = 4kHz LO = -15dBm
Intermodulation (IP2)		47	53		dB	1200 bps Δf = 4kHz LO = -15dBm
Adjacent channel		66	72.5		dB	1200 bps Δf = 4kHz LO = -15dBm
					kHz	Channel spacing 25kHz
Centre frequency acceptance		+/-1.8	+/-2.3		kHz	1200 bps Δf = 4kHz LO = -15dBm
Deviation acceptance			+/-2.2		kHz	1200 bps Δf = 4kHz LO = -15dBm
LO Rejection:-						
0.5dB Sensitivity loss		-59	-55		dBm	Level of local oscillator at the RF input to the LNA
3dB Sensitivity loss		-52	-48	-44	dBm	

SL6610

OPERATION OF SL6610

The SL6610 is a Direct Conversion Receiver designed for use up to 470MHz. It is available in a 28 pin SSOP package and it integrates all the facilities required for the conversion of an RF FSK signal to a base-band data signal.

Low Noise Amplifier

To achieve optimum performance it is necessary to incorporate a Low Noise RF Amplifier at the front end of the receiver. This is easily biased using the on chip voltage and current sources provided.

All voltages and current sources used for bias of the RF amplifier, receiver and mixers should be RF decoupled using suitable capacitors (see fig.4 for a suitable Low-Noise-Amplifier).

Local Oscillator

The Local Oscillator signal is applied to the device in phase quadrature. This can be achieved with the use of two RC networks operating at the -3dB/45° transfer characteristic, giving a full 90° phase differential between the LO ports of the device. Each LO port of the device also requires an equal level of drive from the Oscillator. (see Fig.5).

Gyrator Filters

The on chip filters include an adjustable gyrator filter. This may be adjusted with the use of an additional resistor between pin 4 and GND. This allows flexibility of filter characteristics and also allows for compensation for possible process variations.

Audio AGC

The Audio AGC fundamentally consists of a current sink which is controlled by the audio (baseband data) signal. It has three parameters that may be controlled by the user. These are the Attack (turn on) time, Decay (duration) time and Threshold level (see Fig.6 and 7). See Application note for details.

Regulator

The on chip regulator must be used in conjunction with a suitable PNP transistor to achieve regulation. As the transistor forms part of the regulator feedback loop the transistor should exhibit the following characteristics:-

$$H_{FE} \geq 100 \text{ for } V_{CE} \geq 0.1V$$

Pin Number	Pin Name	Pin Description
1	TPX	X channel pre-gyrator filter test-point. This can be used for input and output
2	MIX-DEC	Mixer bias de-couple pin
3	LOY	LO input channel Y
4	GYRI	Gyrator current adjust pin
5	LOX	LO input channel X
6	VR	VREF 1.0 V internal signal ground
7	TPY	Y channel pre-gyrator filter test point, input or output
8	GTHADJ	Audio AGC gain and threshold adjust. RSSI signal indicator
9	TCADJ	Audio AGC time constant adjust
10	BEC	Battery economy control
11	BATTFL	Battery flag output
12	TPLIMY	Y channel limiter (post gyrator filter) test point, output only
13	VCC2	Supply connection
14	DATAOP	Data output pin
15	TPLIMX	X channel limiter (post gyrator filter) test point, output only
16	BRF2	Bit rate filter 2, input to data output stage
17	BRF1	Bit rate filter 1, output from detector
18	DIG GND	Digital ground
19	VBG	Bandgap voltage output
20	VBATT	Battery flag input voltage
21	VCC1	Supply connection
22	REGCNT	1V regulator control external PNP drive
23	VREG	1V regulator output voltage
24	MIXB	Mixer input B
25	GND	Ground
26	MIXA	Mixer input A
27	IRFAMP	Current source for external LNA. Value of current output will decrease at high mixer input signal levels due to RF AGC
28	IAGCOUT	Audio AGC output current

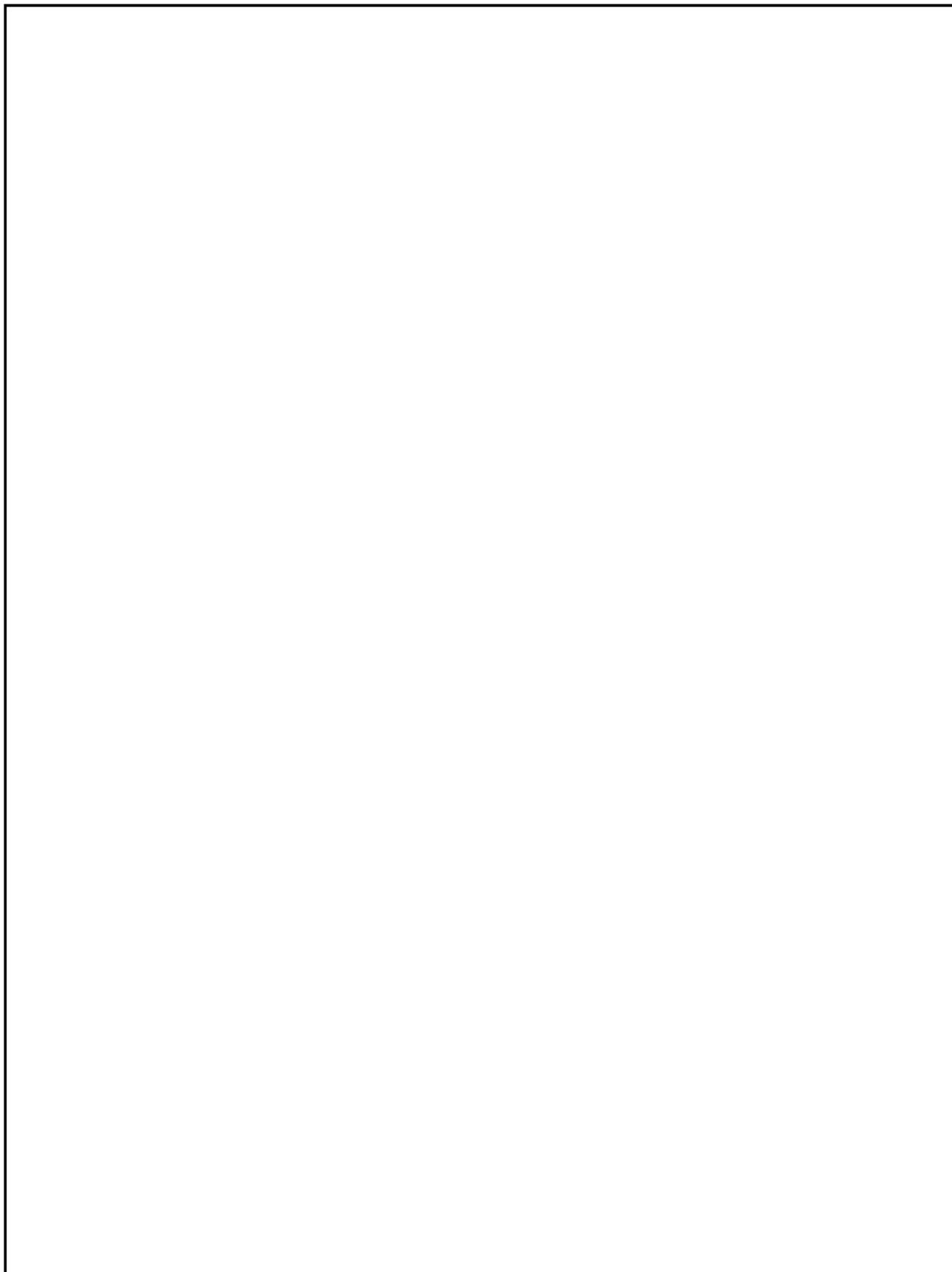

Fig.3 Application circuit board

SL6610

COMPONENTS LIST FOR APPLICATION BOARD At 282MHz, 25kHz Channel Spacing.

(LO Circuit in Fig.3)

Resistors

R1	open circuit
R2	not used
R3	100
R4	100k
R5	1k
R6	1k
R7	100
R8	open circuit
R9	220k
R10	1M
R11	100k ⁽⁶⁾
R12	not used
R13	1k5 ⁽¹⁾
R14	4k7
R15	4k7
R16	33k
R17	not used
R18	0R ⁽³⁾
R19	10k
R20	620
R21	1k
R22	open circuit

Capacitors

C1	1n
C2	2p7
C3	4p7
C4	1n
C5	2p7
C6	2u2
C7	1n
C8	100n
C9	1n ⁽²⁾
C10	2u2
C11	100n
C12	1n
C13	1n
C14	1n
C15	1n
C16	1n
C17	1n
C17a	1n

Notes

1. The values of R13 is determined by the set-up procedure. See Application Note.
2. The value of C9 is determined by the output data rate. Use 2nF for 512bps, 1nF for 1200bps and 470pF for 2400bps.
3. L2 is used in the Audio AGC circuit (see Fig. 6). For the characteristics of the Audio AGC current source see Fig.7. If the audio AGC is not required then the current source (Pin 28) may be disabled by connecting Pin 9 (TCADJ) to VR (Pin 6) and by connecting Pin 28 (IAGCOUT) to Vcc1, (R18). The voltage at Pin 8 may still be used as an RSSI. R9, C8, C14, C19, R17 and D1 may then be omitted. See Fig.6 for AGC component values.

C18	1n
C19	100n
C20	1n
C21	1n
C22	not used
C23	1n
C24	1n
C25	1n
C26	6p8
C27	1n
C28	1n
C29	100p
C30	2u2
C31	2u2
C32	4p7
C33	4p7
C34	3p3
C35	not used
VC1	1-10p
VC2	1-10p
VC3	1-10p

Inductors

L1	68n ⁽⁴⁾
L2	not used ⁽³⁾
L3	470n
L4	39n
L5	680n

Active Components

Q1	FMMT589
Q2	2SC5065 (Toshiba)
Q3	BFT25A (Philips)
Q4	not used
Q5	2SC5065 (Toshiba)
D1	Panasonic MA862 ⁽⁵⁾

Misc

T1	30nH 1:1 Coilcraft M1686-A
Xtal	5th Overtone 94.075MHz

4. L1 and C26 form the low noise matching network for the RF amplifier. The values given are for the RF amplifier specified in the Applications Circuit with no Audio AGC connected. i.e. R17 and D1 omitted.
5. Suggested diode for use with the Audio AGC circuit (see Fig.6) (D1 is not included on the general demonstration circuit).
6. The value of R11 is dependent on the data output load. R11 should allow sufficient current to drive the data output load.

COMPONENTS LIST FOR APPLICATION BOARD At 470MHz, 25kHz Channel Spacing.
(LO circuit is 50Ω network as in Fig.5 - crystal oscillator not specified)

Resistors

R1	open circuit
R2	not used
R3	100
R4	100k
R5	100
R6	100
R7	100
R8	open circuit
R9	220k
R10	1M
R11	100k ⁽²⁾
R12	300 ⁽³⁾
R13	3k9 ⁽¹⁾
R14	4k7
R15	4k7
R16	33k
R17	open circuit ⁽⁴⁾
R18	0R ⁽⁴⁾
R22	open circuit
C14	1n
C15	1n
C16	1n
C17	1n
C18	1n
C19	100n
C20	1n
C21	1n
C22	not used
C23	not used
C24	1n
C25	1n
C26	open circuit
C27	not used
C28	not used
C29	100p
C30	2u2
C31	2u2
C34	1p5
VC1	1-3pF

Capacitors

C1	1n
C2	3.3pF
C3	1n
C4	1n
C5	3.9pF
C6	2u2
C7	1n
C8	100n
C9	1n ⁽²⁾
C10	2u2
C11	100n
C12	1n
C13	1n

Inductors

L1	47nH ⁽⁵⁾
L2	not used ⁽³⁾
T1	16nH 2 Turn 1:1 (Coilcraft) Q4123-A

Active Components

Q1	Zetex FMMT589
Q2	Philips BFT25A
Q3	Not Used
Q4	Philips BFT25A ⁽³⁾
Q5	Philips BFT25A
D1	Panasonic MA862 ⁽⁶⁾

Notes

- The values of R13 is determined by the set-up procedure. See Application Note.
- The value of "C9" is determined by the output data rate. Use 2nF for 512bps, 1nF for 1200bps and 470pF for 2400bps.
- R12 & Q4 form a dummy load for the regulator. Permitted load currents for the regulator are 250μA to 5mA. The 1V regulator (output Pin 23) can be switched off by connecting Pin 23 directly to VCC2. Q1, Q4, R12 and C12 must then be omitted
- L2 is used in the Audio AGC circuit (see Fig.6). For the characteristics of the Audio AGC current source see figure 7. If the Audio AGC is not required then the current source (Pin 28) may be disabled by connecting Pin 9 (TCADJ) to VR (Pin 6) and by connecting Pin 28 (IAGCOUT) to Vcc1, (R18). The voltage at Pin 8 may still be used as an RSSI. R9, C8, C14, C19, R17 and D1 may then be omitted.
- L1 and C26 form the low noise matching network for the RF amplifier. The values given are for the RF amplifier specified in the Applications Circuit with no Audio AGC connected. i.e. R17 and D1 omitted.
- Suggested diode for use with the Audio AGC circuit (D1 is not included on the general demonstration circuit).
- The value of R11 is dependent on the data output load. R11 should allow sufficient current to drive the data output load.

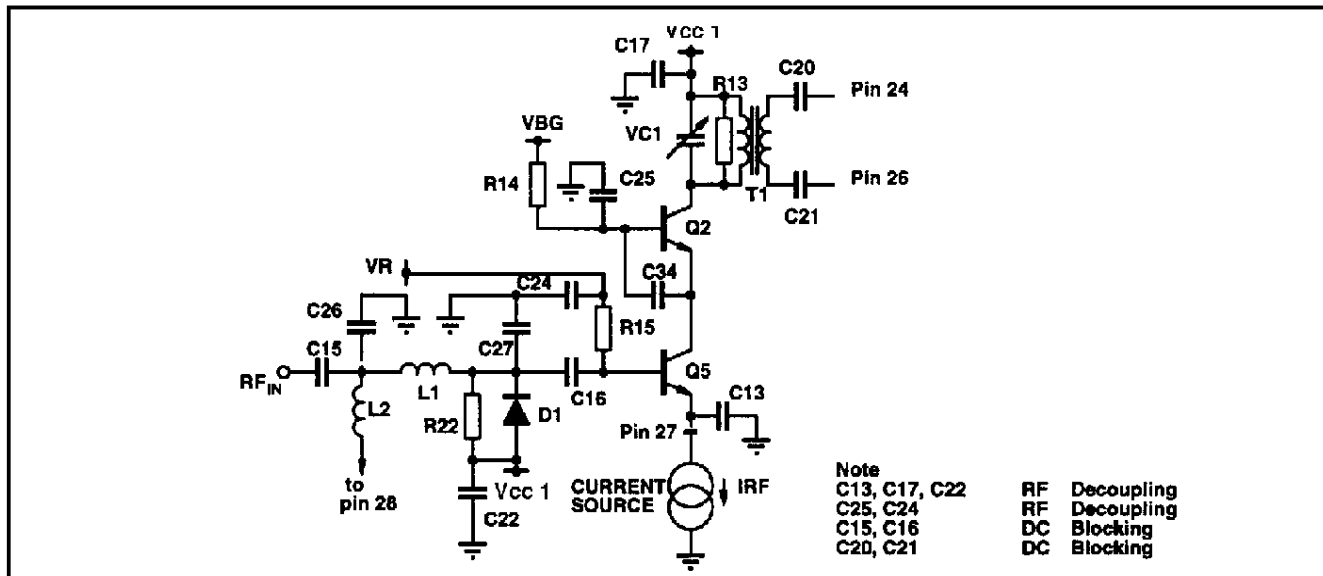

Fig.4 RF amplifier

RF Amplifier Components Values

Resistors		Capacitors		Active components
R14, R15	4k7	C13, C15	1nF	D1 MA862 (Panasonic)
R13	see note 1	C16, C17	1nF	
R22	47k	C20, C21	1nF see note 2	
		C24, C25	1nF	
		L2	820nH	

Notes:

- (1) The value of R13 is determined by the set up procedure (See "Set up for optimum performance").
- (2) C20 and C21 are purely for demonstration purposes. Pin 24 and Pin 26 may be DC coupled provided that no DC voltage is applied to the mixer inputs.

Frequency Dependent Components

	153MHz	280MHz	450MHz
C26	not used	6.8p	not used
C27	not used	not used	not used
L1	150nH	68nH	39nH
C34	3p3	2p2	1p5
T1	100nH	30nH	16nH
	Coilcraft N2261-A	Coilcraft M1686-A	Coilcraft Q4123-A
VC1	1-10pF	1-10pF	1-3pF
Q4, Q5	Toshiba 2SC5065	Toshiba 2SC5065	Philips BFT25A

(See also Lo drive Network)

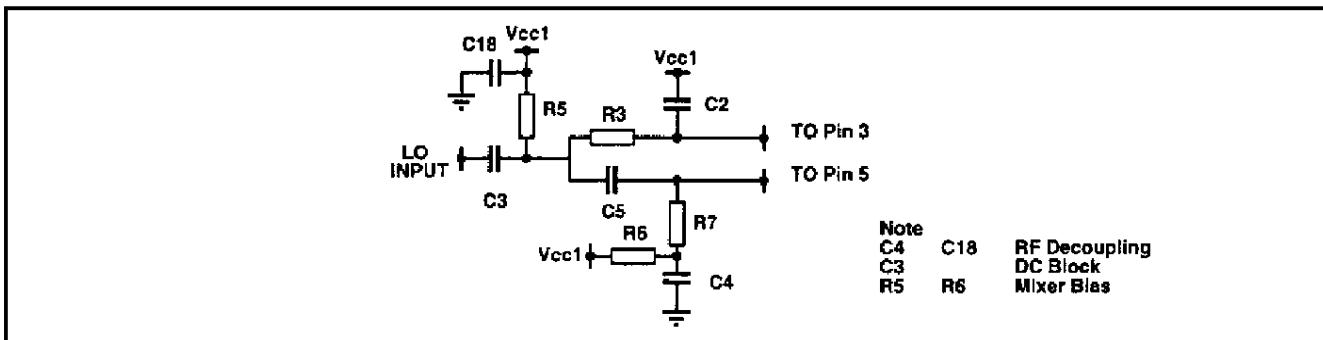

Fig.5 Local oscillator drive network

LO Drive Network Component Values

50Ohm input impedance (External LO injection)

	153MHz	280MHz	450MHz
C2	10p	5p6	3p3
C5	10p	5p6	3p9
C3, C4, C18 = 1n			
R3, R5, R6, R7 = 100Ohms			

Higher Input Impedance (crystal oscillator input)

	153MHz	280MHz	450MHz
C3	Set by load allowable on crystal oscillator (typical 4p7)		
C2	10p	5p6	3p3
C5	10p	5p6	3p9
R3	100	100	100
R7	100	100	100
R5, R6 = 1k			
C4, C18 = 1n			

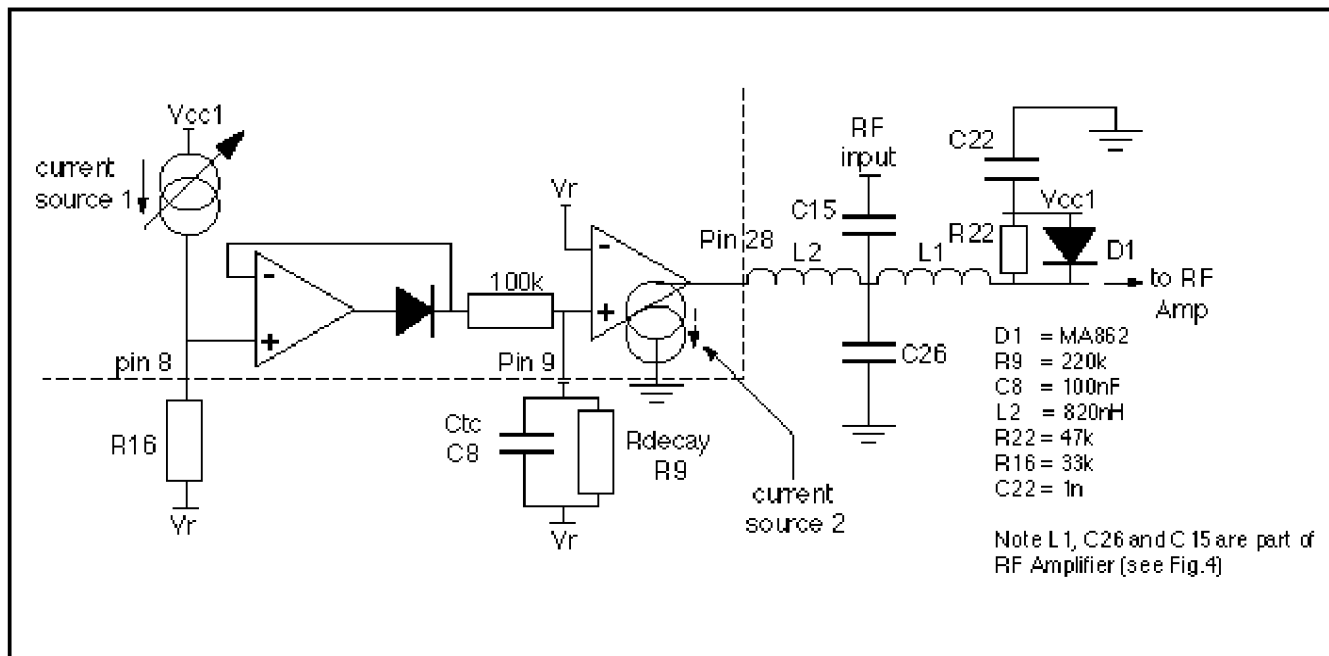

Fig.6 AGC Schematic

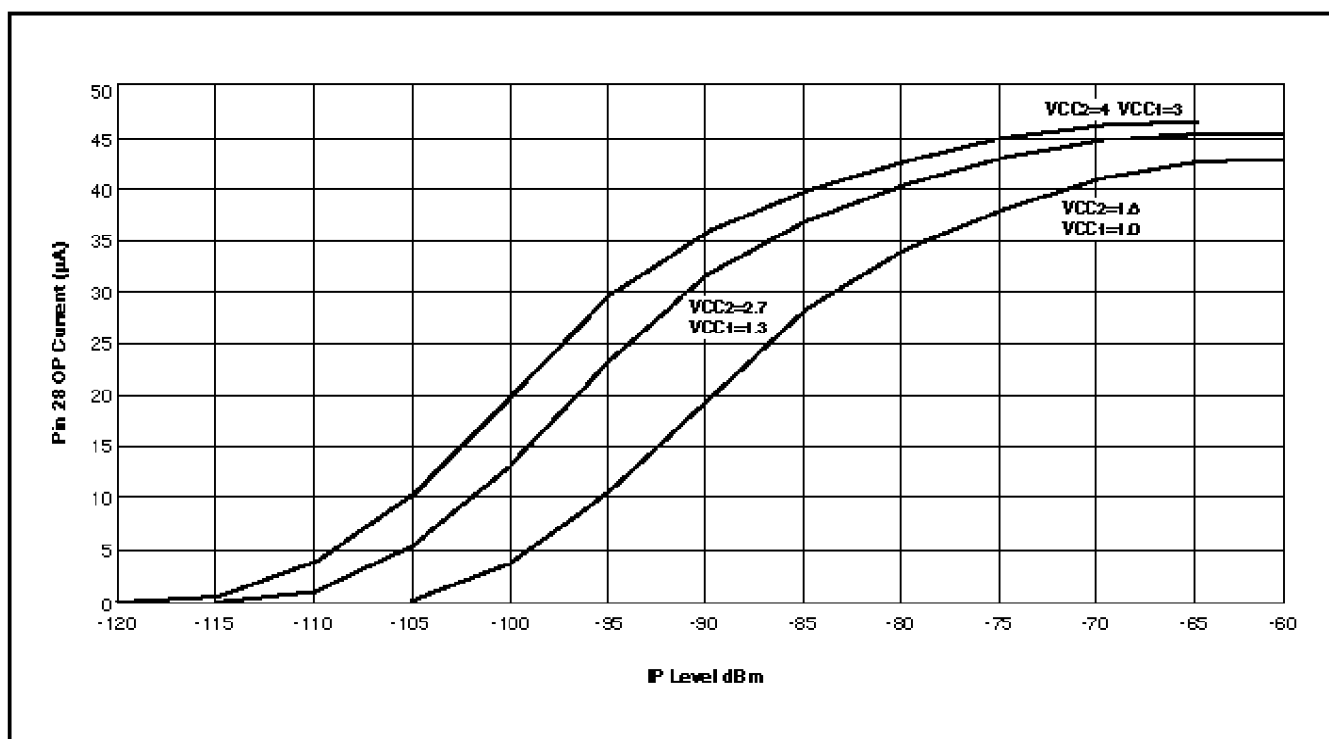

Fig.7 Audio AGC current vs. IP power at 25°C

SL6610

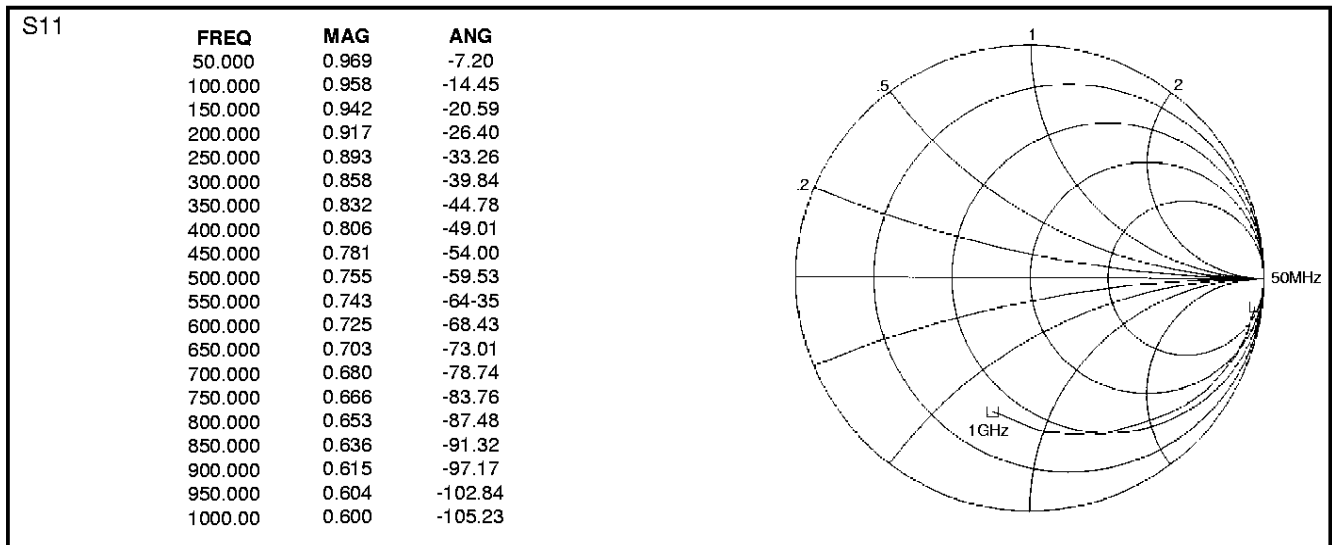

Fig.8a SL6609A Mixer A input S-Parameters

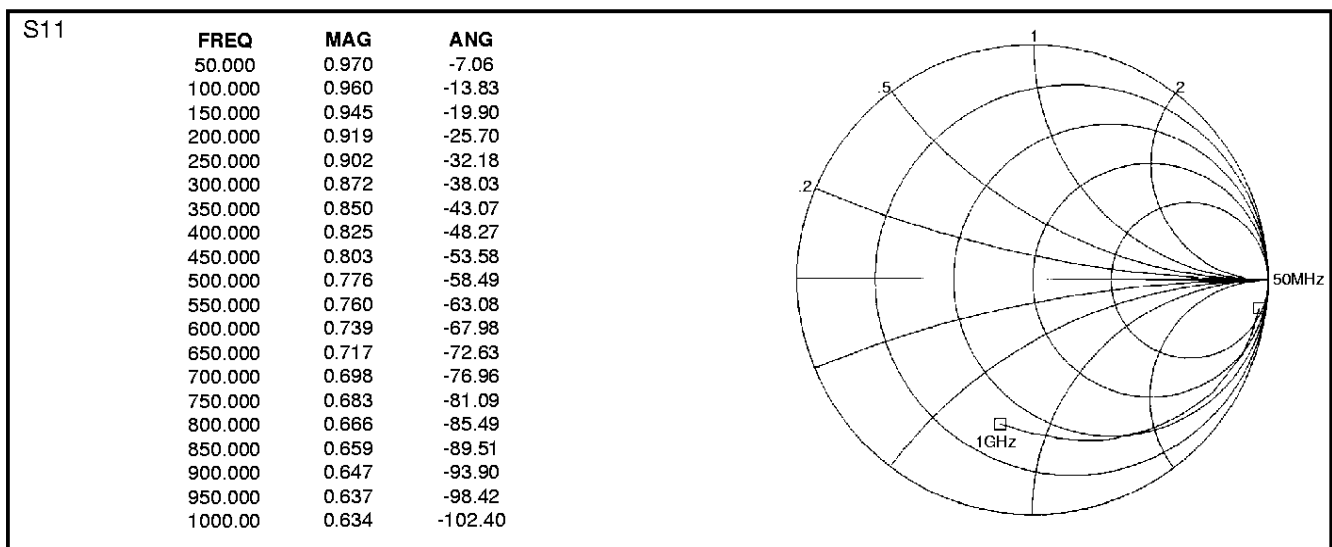

Fig.8b SL6609A Mixer B input S-Parameters

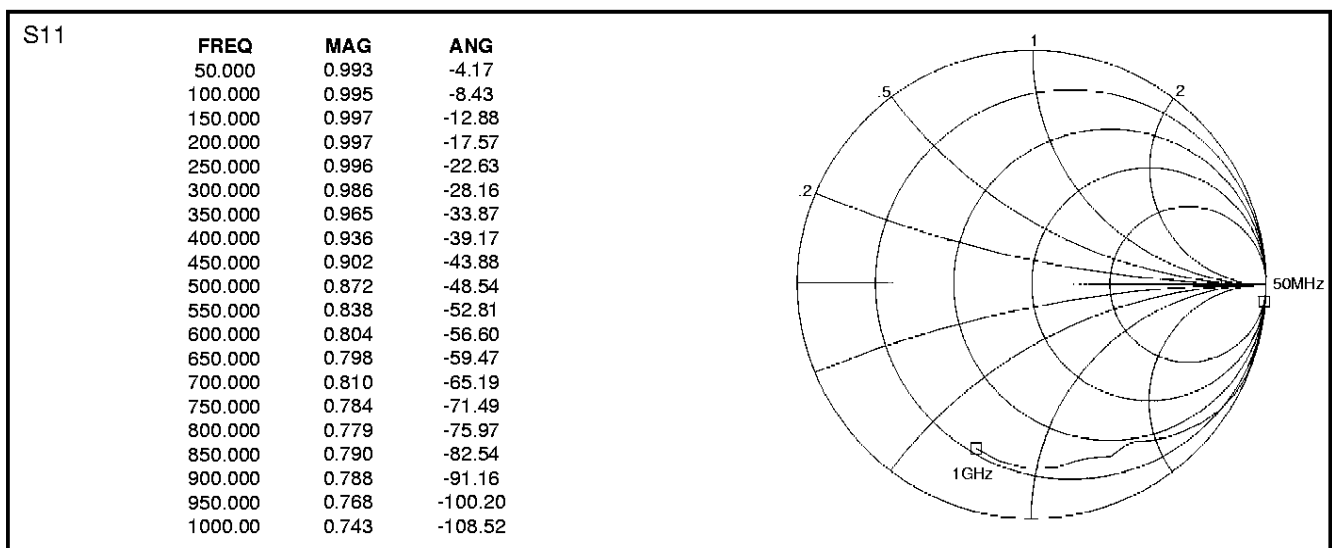

Fig.9 SL6609A LO X,Y inputs S-Parameters

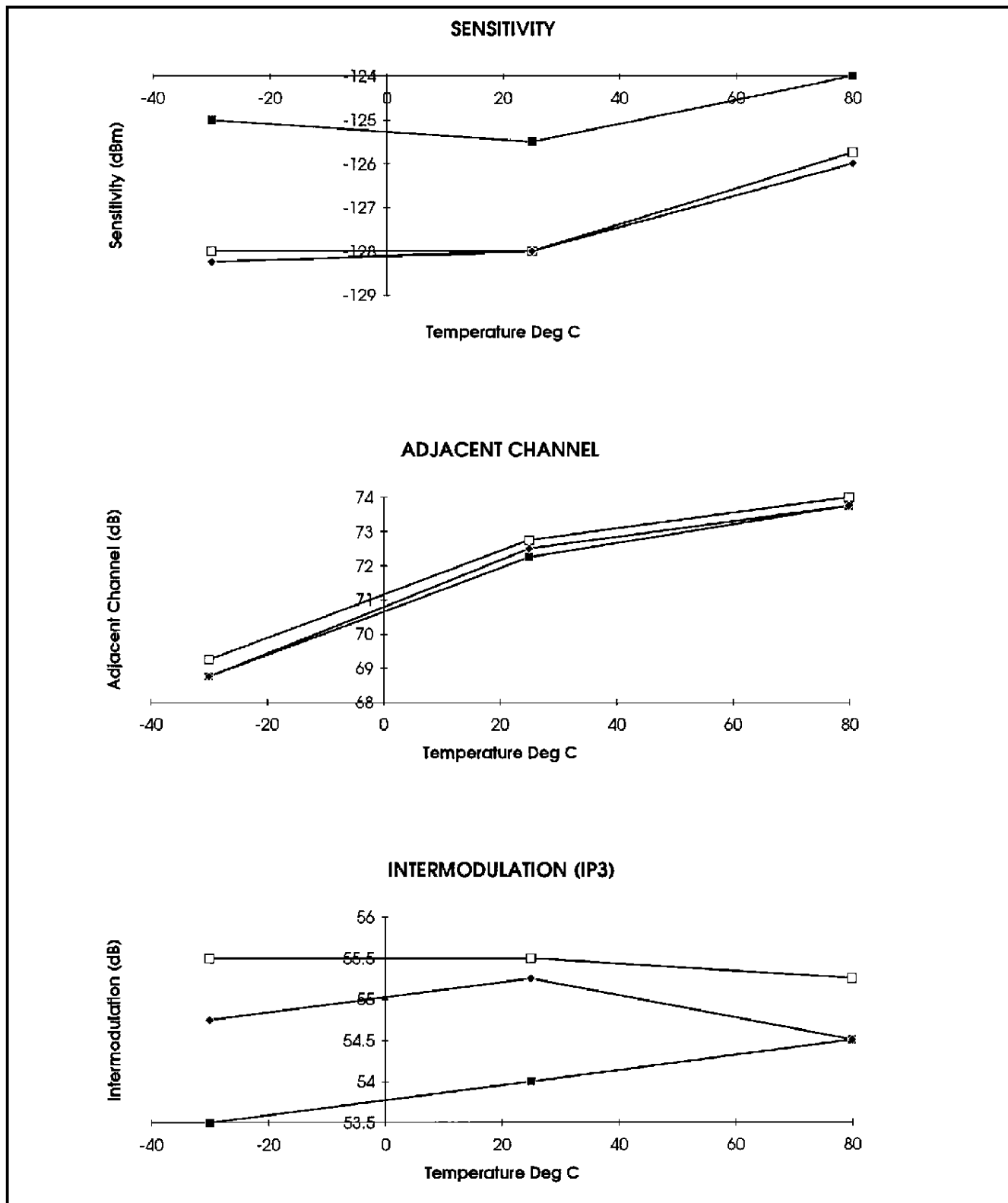
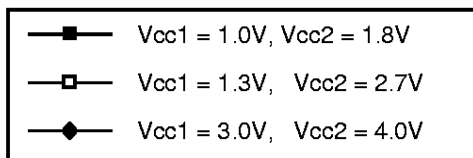

Fig.10a AC parameters vs. supply and temperature

Conditions:- 282MHz demonstration board i.e. 20dB LNA, 2dB noise figure, carrier frequency 282MHz, 1200bps baud rate, 4kHz deviation frequency, BER 1 in 30.



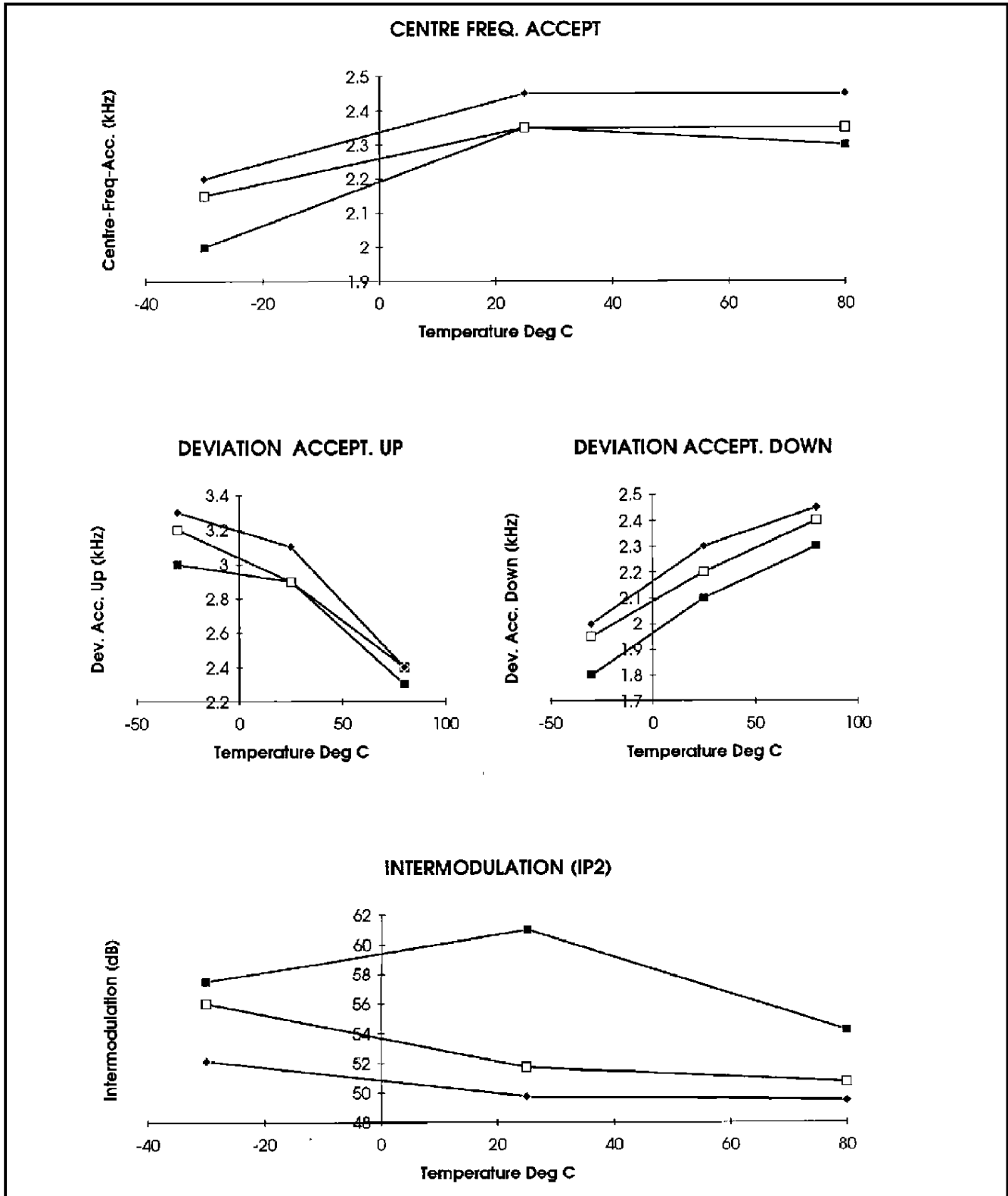
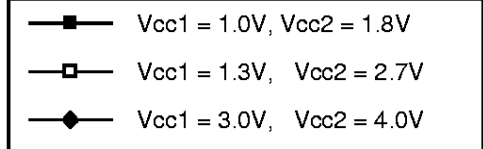

Fig.10b AC parameters vs. supply and temperature

Conditions:- 282MHz demonstration board i.e. 20dB LNA, 2dB noise figure, carrier frequency 282MHz, 1200bps baud rate, 4kHz deviation frequency, BER 1 in 30.



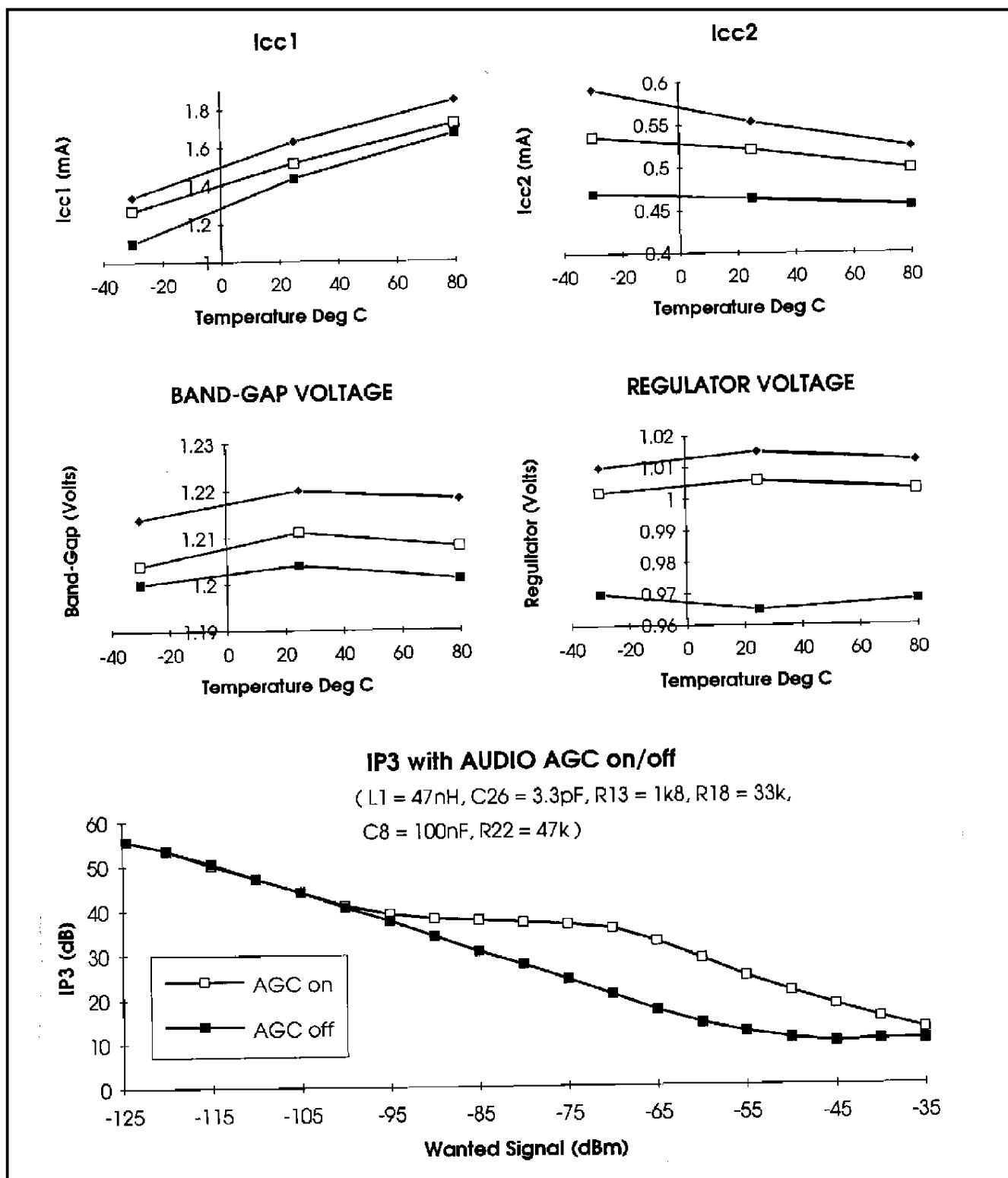

Fig.11 DC parameters vs. supply and temperature (IP3 vs audio AGC both on and off)

Conditions:- ICC1 includes 500µA LNA current but does not include the regulator supply (audio AGC inactive). ICC2 measured with BATT FLAG and DATA O/P HIGH, Fc = 282MHz.

Note 1- IP3 is level above wanted needed to reduce receiver to 1 in 30 B.E.R.

■	Vcc1 = 0.98V, Vcc2 = 1.78V
□	Vcc1 = 1.3V, Vcc2 = 2.7V
◆	Vcc1 = 3.0V, Vcc2 = 4.0V

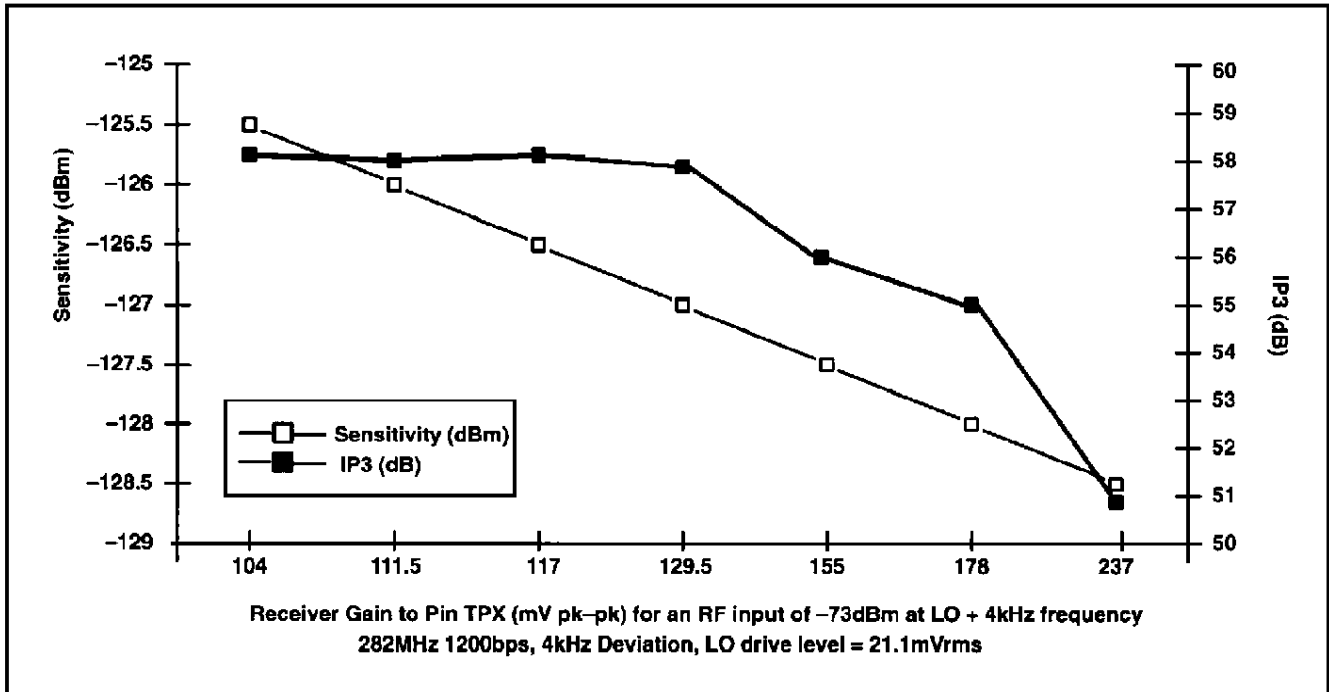

Fig.12 Sensitivity, IP3 vs Receiver Gain

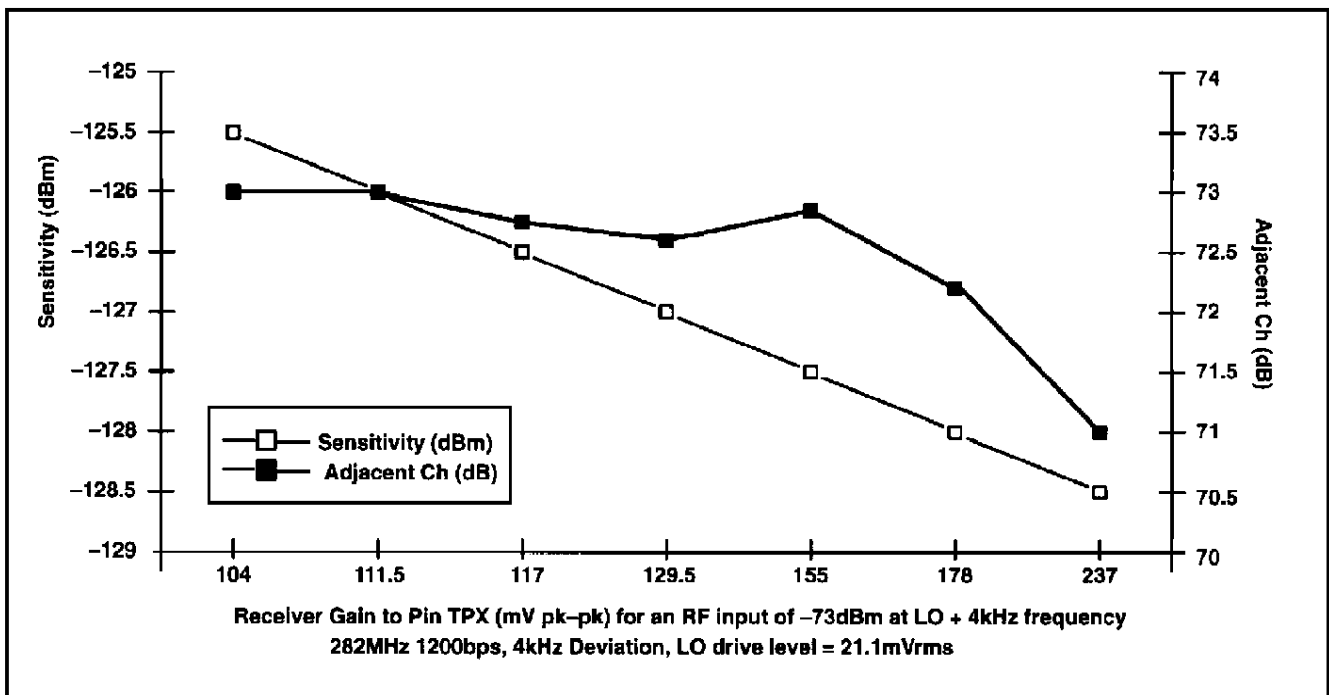

Fig.13 Sensitivity, adjacent Channel vs Receiver Gain

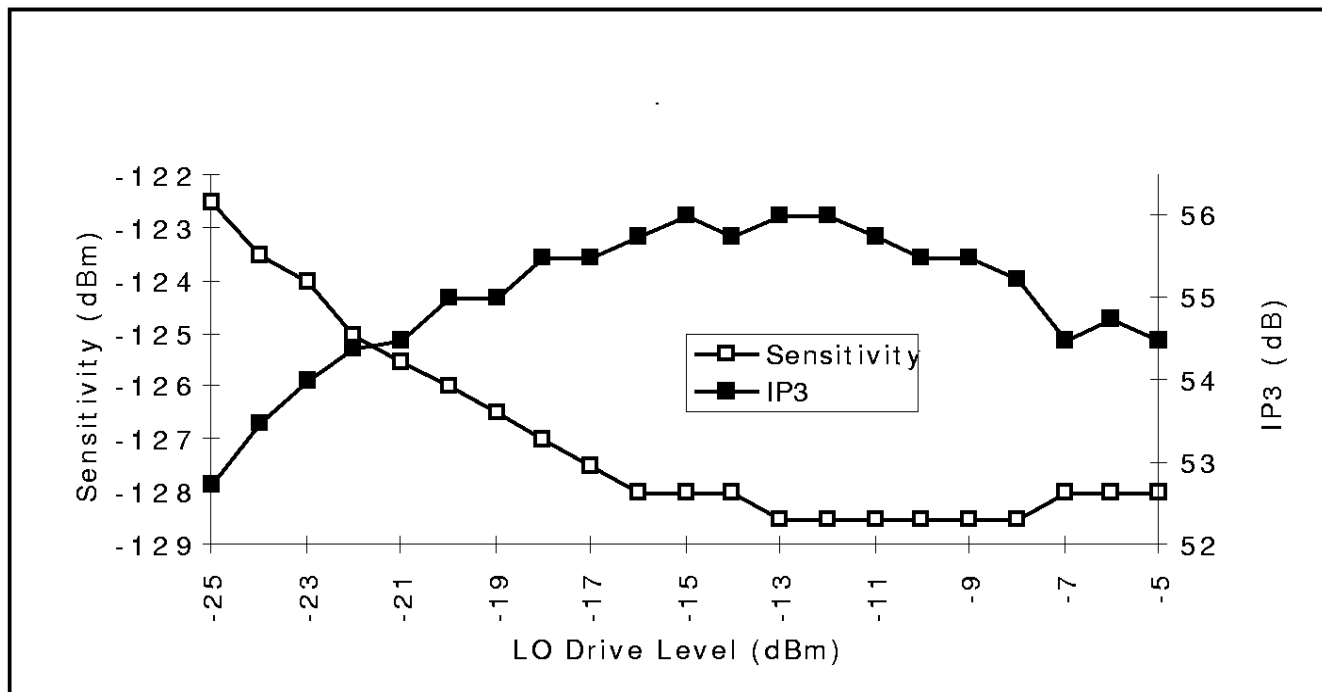

Fig.14 Sensitivity, IP3 vs LO level

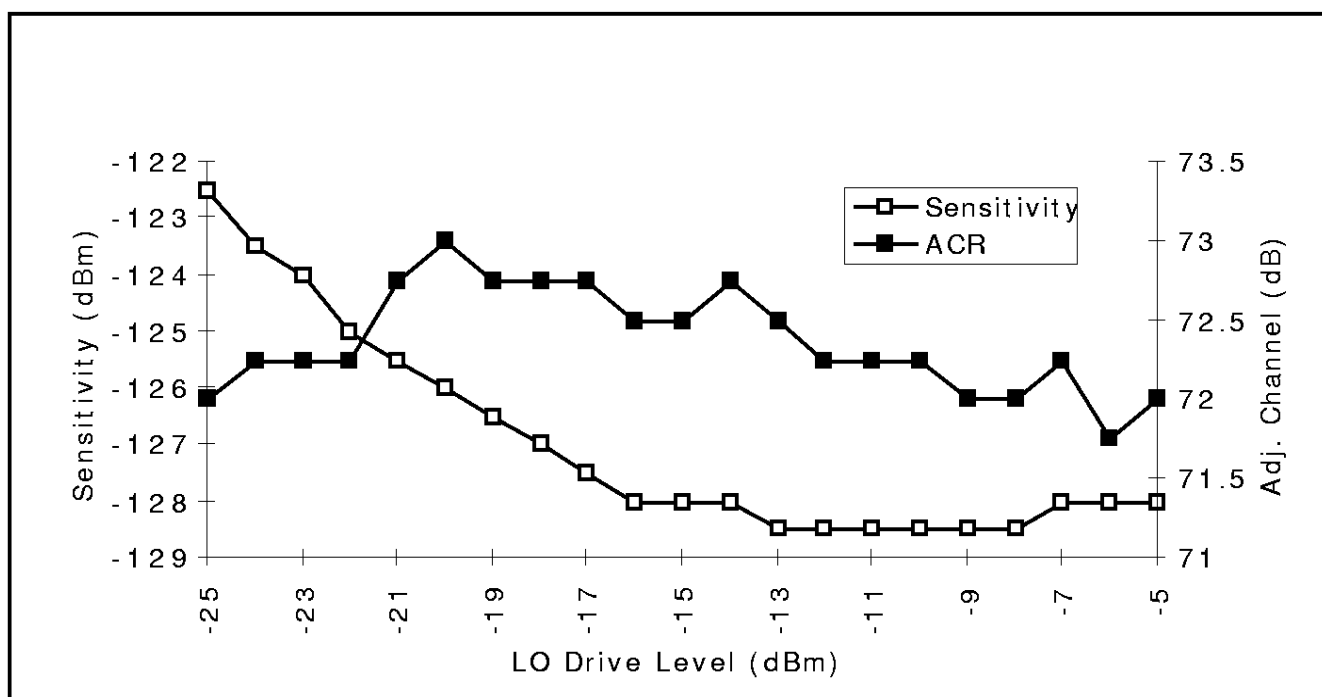
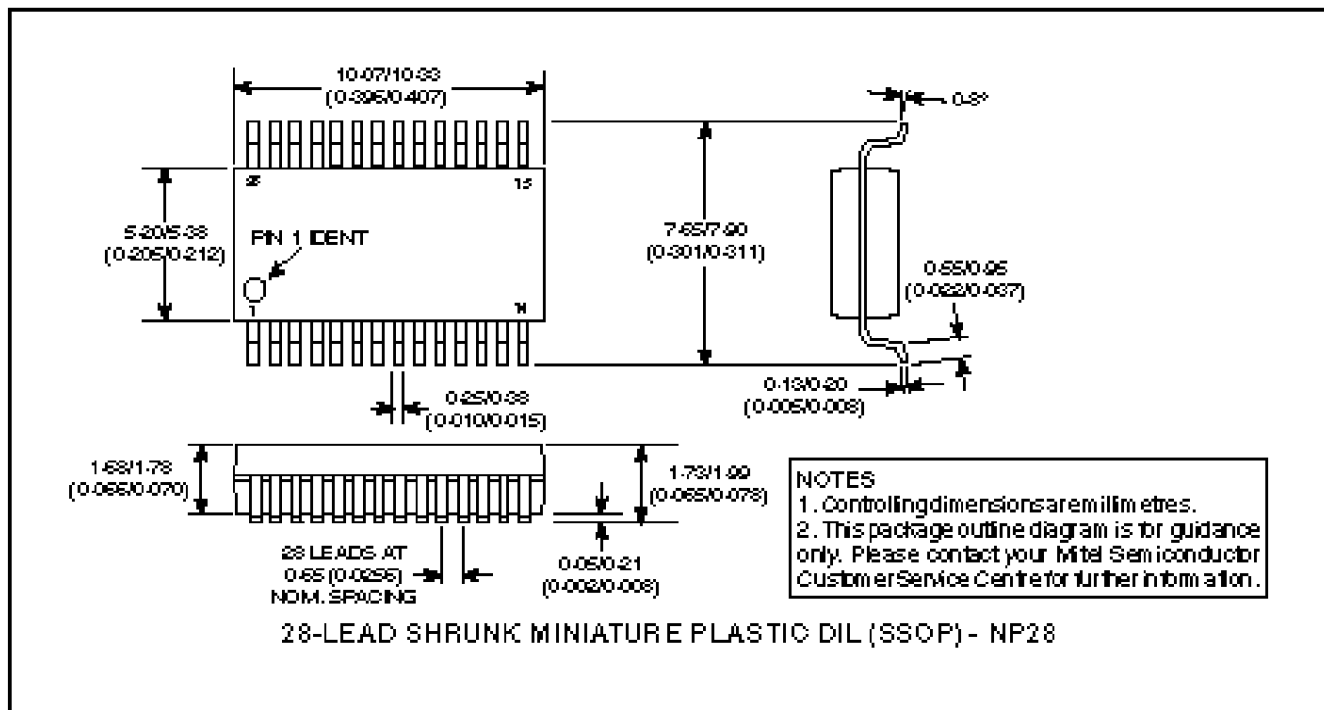

Fig.15 Sensitivity, Adjacent Channel vs LO level

SL6610

PACKAGE DETAILS

Dimensions are shown thus: mm (in)



HEADQUARTERS OPERATIONS
MITEL SEMICONDUCTOR
Cheney Manor, Swindon,
Wiltshire SN2 2QW, United Kingdom.
Tel: (01793) 518000
Fax: (01793) 518411

MITEL SEMICONDUCTOR
1500 Green Hills Road,
Scotts Valley, California 95066-4922
United States of America.
Tel (408) 438 2900
Fax: (408) 438 5576/6231

Internet: <http://www.gpsemi.com>
CUSTOMER SERVICE CENTRES

- FRANCE & BENELUX Les Ulis Cedex Tel: (1) 69 18 90 00 Fax : (1) 64 46 06 07
- GERMANY Munich Tel: (089) 419508-20 Fax : (089) 419508-55
- ITALY Milan Tel: (02) 6607151 Fax: (02) 66040993
- JAPAN Tokyo Tel: (03) 5276-5501 Fax: (03) 5276-5510
- KOREA Seoul Tel: (2) 5668141 Fax: (2) 5697933
- NORTH AMERICA Scotts Valley, USA Tel: (408) 438 2900 Fax: (408) 438 5576/6231
- SOUTH EAST ASIA Singapore Tel: (65) 3827708 Fax: (65) 3828872
- SWEDEN Stockholm Tel: 46 8 702 97 70 Fax: 46 8 640 47 36
- TAIWAN, ROC Taipei Tel: 886 2 25461260 Fax: 886 2 27190260
- UK, EIRE, DENMARK, FINLAND & NORWAY
Swindon Tel: (01793) 726666 Fax : (01793) 518582

These are supported by Agents and Distributors in major countries world-wide.

© Mitel Corporation 1998 Publication No. DS4003 Issue No. 2.2 September 1995

TECHNICAL DOCUMENTATION - NOT FOR RESALE. PRINTED IN UNITED KINGDOM

This publication is issued to provide information only which (unless agreed by the Company in writing) may not be used, applied or reproduced for any purpose nor form part of any order or contract nor to be regarded as a representation relating to the products or services concerned. No warranty or guarantee express or implied is made regarding the capability, performance or suitability of any product or service. The Company reserves the right to alter without prior notice the specification, design or price of any product or service. Information concerning possible methods of use is provided as a guide only and does not constitute any guarantee that such methods of use will be satisfactory in a specific piece of equipment. It is the user's responsibility to fully determine the performance and suitability of any equipment using such information and to ensure that any publication or data used is up to date and has not been superseded. These products are not suitable for use in any medical products whose failure to perform may result in significant injury or death to the user. All products and materials are sold and services provided subject to the Company's conditions of sale, which are available on request.

All brand names and product names used in this publication are trademarks, registered trademarks or trade names of their respective owners.